



Stinger®

Copper Loop Test (CLT) Module Guide

Copyright © 2000, 2001, 2002 Lucent Technologies Inc. All rights reserved.

This material is protected by the copyright laws of the United States and other countries. It may not be reproduced, distributed, or altered in any fashion by any entity (either internal or external to Lucent Technologies), except in accordance with applicable agreements, contracts, or licensing, without the express written consent of Lucent Technologies. For permission to reproduce or distribute, please email your request to techcomm@lucent.com.

Notice

Every effort was made to ensure that the information in this document was complete and accurate at the time of printing, but information is subject to change.

European Community (EC) RTTE compliance

 Hereby, Lucent Technologies, declares that the equipment documented in this publication is in compliance with the essential requirements and other relevant provisions of the Radio and Telecommunications Technical Equipment (RTTE) Directive 1999/5/EC.

To view the official *Declaration of Conformity* certificate for this equipment, according to EN 45014, access the Lucent INS online documentation library at <http://www.lucentdocs.com/ins>.

Safety, compliance, and warranty Information

Before handling any Lucent Access Networks hardware product, read the *Edge Access Safety and Compliance Guide* included in your product package. See that guide also to determine how products comply with the electromagnetic interference (EMI) and network compatibility requirements of your country. See the warranty card included in your product package for the limited warranty that Lucent Technologies provides for its products.

Security statement

In rare instances, unauthorized individuals make connections to the telecommunications network through the use of access features.

Trademarks

Lucent, the Lucent logo, and all Lucent brand and product names are trademarks or registered trademarks of Lucent Technologies Inc. Other brand and product names are trademarks of their respective holders.

Ordering Information

You can order the most up-to-date product information and computer-based training online at <http://www.lucentdocs.com/bookstore>.

Feedback

Lucent Technologies appreciates customer comments about this manual. Please send them to techcomm@lucent.com.

Customer Service

Product and service information, and software upgrades, are available 24 hours a day. Technical assistance options accommodate varying levels of urgency.

Finding information and software

To obtain software upgrades, release notes, and addenda for this product, log in to Lucent OnLine Customer Support at <http://www.lucent.com/support>.

Lucent OnLine Customer Support also provides technical information, product information, and descriptions of available services. The center is open 24 hours a day, seven days a week. Log in and select a service.

Obtaining technical assistance

Lucent OnLine Customer Support at <http://www.lucent.com/support> provides access to technical support. You can obtain technical assistance through email or the Internet, or by telephone. If you need assistance, make sure that you have the following information available:

- Active service or maintenance contract number, entitlement ID, or site ID
- Product name, model, and serial number
- Software version
- Software and hardware options If supplied by your carrier, service profile identifiers (SPIDs) associated with your line
- Your local telephone company's switch type and operating mode, such as AT&T 5ESS Custom or Northern Telecom National ISDN-1
- Whether you are routing or bridging with your Lucent product
- Type of computer you are using
- Description of the problem

Obtaining assistance through email or the Internet

If your services agreement allows, you can communicate directly with a technical engineer through Email Technical Support or a Live Chat. Select one of these sites when you log in to <http://www.lucent.com/support>.

Calling the technical assistance center (TAC)

If you cannot find an answer through the tools and information of Lucent OnLine Customer Support or if you have a very urgent need, contact TAC. Access Lucent OnLine Customer Support at <http://www.lucent.com/support> and click Contact Us for a list of telephone numbers inside and outside the United States.

Alternatively, call 1-866-LUCENT8 (1-866-582-3688) from any location in North America for a menu of Lucent services. Or call +1 510-769-6001 for an operator. If you do not have an active services agreement or contract, you will be charged for time and materials.

Contents



Customer Service	iii
Chapter 1 Overview of the CLT Module and Copper Loop Testing.....	1-1
Overview of CLT module capabilities.....	1-1
CLT module models	1-2
Metallic loop testing	1-2
Prequalification tests.....	1-2
Troubleshooting and maintenance support.....	1-3
CLT module installation	1-3
System description	1-4
System operation.....	1-4
Supported tests.....	1-6
DMM tests.....	1-6
Line tests	1-7
TDR tests.....	1-9
Other functions and commands	1-11
How to perform tests.....	1-12
Chapter 2 Copper Loop Testing through the Command-Line Interface	2-1
Using the command-line interface.....	2-1
Performing tests by entering clt commands.....	2-1
Performing tests using clt profiles	2-1
Enabling tester and copper loop access	2-2
Enabling test access with the cltActivate and cltDeactivate commands	2-2
Enabling test access through the CLT-Access profile	2-3
Enabling loop testing with one CLT module and multiple Stinger units.....	2-5
Selecting a test.....	2-6
Selecting tests with the cltCmd command.....	2-7
Selecting tests through the Clt-Command profile	2-22
Determining test results	2-32
Chapter 3 Copper Loop Testing through SNMP	3-1
Ascend-CLTM-MIB groups	3-1
CLT module access group—cltmAccess.....	3-1
CLT module command group—cltmCmd	3-3
CLT module results group—cltmRslt	3-14

Appendix A CLT Module Specifications.....	A-1
Physical specifications	A-1
Connector pinouts and specifications.....	A-2
SERIAL connector.....	A-2
TEST PAIR connector.....	A-3
AUX connector	A-3
Port connector	A-4
Index	Index-1

Overview of the CLT Module and Copper Loop Testing



1

Overview of CLT module capabilities	1-1
CLT module models	1-2
Metallic loop testing	1-2
CLT module installation	1-3
CLT module installation	1-3
System description	1-4
System operation	1-4
Supported tests.	1-6
How to perform tests	1-12

The Stinger copper loop test (CLT) module allows the Stinger user to individually test all copper loop pairs terminated on Stinger line protection modules (LPMs). The built-in test head performs the necessary analog and digital tests to qualify and maintain copper loops. You can test each pair without disconnecting any cables. Copper loop testing can also be conducted through the use of an external head and a path selector module (PSM).

Overview of CLT module capabilities

The CLT module has a built-in test head that can perform the following tests:

- Digital multimeter (DMM) tests—measure ac and dc voltage, dc delta, resistance, loop resistance, capacitance, and loop length.
- Line tests—measure wideband noise, impulse noise, load coil detection, loop resistance, insertion loss and signal to noise.
- Time-domain reflectometry (TDR) tests—locate bridgetaps, load coils, water-saturated cable sections, short circuits, and cable faults.
- Tone and signaling tests—measure send and receive tones and detect signals and voice.

Most tests supported are single ended and do not require equipment or termination at the customer premises equipment (CPE) end of the loop. The insertion loss, signal-to-noise and detap tests require the use of additional equipment at the CPE

end of the loop. The loop resistance test requires that the loop be shorted at the CPE end.

Testing by the built-in test head can be initiated through the TAOS command-line interface (CLI) or Simple Network Management Protocol (SNMP). Test results are reported through a TAOS profile or SNMP.

For physical specifications and pinouts, see Appendix A, “CLT Module Specifications.”

CLT module models

Current CLT module models use a test head with extended capabilities and supports up to 72 ports per LIM. The STGR-CLTE module can be used with both the Stinger FS and FS+ chassis. Only 48 ports are supported when it is used with the FS chassis. The STGRSL-CLTE-72 and STGRRT-CLTE-72 modules are designed for use the Stinger LS and RT respectively. They support testing with LIMs that have up to 72 ports.

Tests that are only supported by the STGR-CLTE, STGRSL-CLTE and STGRRT-CLTE models are so marked in this document. All other tests are supported by both the CLT and CLTE models.

Metallic loop testing

Metallic loop testing is used to prequalify, install, and maintain xDSL loops. Various kinds of tests can be used to ensure that a particular loop can support the desired xDSL protocol. The CLT module has the capability to perform these tests.

Two methods of testing exist, single-ended and double-ended. Single-ended tests require test equipment at only the central office (CO) or digital loop carrier (DLC) end of the loop. Double-ended testing requires additional equipment and the presence of a technician at the customer premise equipment (CPE) end as well.

Prequalification testing is performed to determine if a particular loop can support an xDSL service before installation. Single-ended tests from the CO can provide up to a 95% confidence level that a loop will support xDSL services when installed.

Installation and maintenance tests are used to support existing xDSL installations. These tests are typically used to troubleshoot problems that suddenly occur on a particular loop. Most often, problems result from deterioration of or accidental breaks or splices in cables.

Prequalification tests

All of the following prequalification tests are single ended.

Line length measurement

The performance of xDSL signals is sensitive to the distance between the CO and the customer. A reasonable estimation of line length can be made using a single-ended capacitance measurement.

Load coil detection

Load coils are inductors that have been added to subscriber loops of more than 18,000 feet (5486 meters) to improve voice quality. When present, load coils

completely block transmission of xDSL signals. Over the years, as old loops have been rearranged, many unneeded load coils have been left on existing copper loops.

Load coil detection determines the number of load coils and their distance from the CO. Since most coils are no longer needed, a technician can be dispatched to remove the coil and make the loop available for xDSL use.

Noise measurement

Wideband and impulse noise measurement is useful for detection of signals and other transmissions in the same binder group. Analysis of the noise frequencies can help identify the exact source of the noise. Particular frequencies can adversely affect the performance of certain xDSL services.

Metallic fault tests

Metallic fault tests include the measurement of dc and ac voltage, resistance, and capacitance. DC and AC Thevenin loop resistance tests are also available. Measurements can be made tip to ring, tip to ground, and ring to ground. In addition to the detection of such faults as foreign voltages, metallic testing can assess the balance of each line. Imbalance of tip-to-ground and ring-to-ground parameters can adversely affect xDSL performance.

Bridge tap detection

A bridge tap is any unterminated part of a loop not in the direct path between the CPE and the CO. Bridge taps are typically abandoned connections that were previously used to provide additional services to a customer's premises. A very long bridge tap—more than 6000 feet (1830 meters)—can affect xDSL performance.

Splitter detection

Splitters are used to separate the analog telephone service signal and the DSL signal. The presence of a splitter with dc blocking capacitors can sometimes cause inaccurate copper loop test results. Detection of splitters is a useful diagnostic tool.

Splitter bypass

If a splitter with dc blocking capacitors is present in the loop circuit, dc voltage, isolation, and loop resistance testing cannot be performed. You can use this feature to set certain brands of splitters to bypass mode.

Troubleshooting and maintenance support

Many of the prequalification tests can be used to troubleshoot xDSL loop failures. TDR testing can be used to detect cable faults including shorts, opens, and damaged sections.

CLT module installation

The CLT module is installed in place of an line protection module (LPM) behind (Stinger FS or Stinger FS+) or next to (Stinger LS or Stinger RT) the slot chosen for an optional spare line interface module (LIM). With the Stinger FS or Stinger FS+, the slot in front of the CLT module must either be empty or used for a spare LIM.

With the Stinger LS or Stinger RT, the slot to the left of the CLT can still be used for an active LIM if desired. Individual ports on this LIM can be either active or redundant.

If no spare LIM is used, for the Stinger FS or Stinger FS+, testing can be performed in looking-out mode but not in bridging mode. Testing can be done in either mode for the Stinger LS or Stinger RT. All LIMs must use a line protection module (LPM) with port redundancy (LPM-RP). Table 1-1 shows the required modules for different test modes.

If an external test head is to be used, a port selector module (PSM) with the appropriate software license can be installed in place of the CLT. The PSM contains the necessary circuitry to select and connect the copper loop to be tested to external terminals on the PSM. See the section entitled “TEST PAIR connector” on page A-3. The external test head can then be connected to these terminals to complete the test circuit.

Table 1-1. Modules required for different CLT test modes

Stinger chassis	Bridged mode	Looking out mode	Redundant mode
FS, FS+	CLT or PSM, LPM-RP, redundant LIM	CLT or PSM, LPM-RP	CLT or PSM, LPM-RP, redundant LIM
LS, RT	CLT or PSM, LPM-RP	CLT or PSM, LPM-RP	CLT or PSM, LPM-RP, redundant LIM or LIM port.

System description

The CLT module consists of a PSM motherboard combined with a daughterboard containing the test head. Users wishing to perform tests with an external test head can use a PSM alone.

The CLT module or PSM is equipped to access any port on any LIM that is equipped with an LPM-RP. Most users equip all the LIMs in their system with LPM-RPs. Most users also have a redundant (spare) LIM plugged in front of or next to the CLT module.

LIMs and LPMs plug into the midplane in the Stinger chassis. The midplane contains trace pairs that can be accessed by both LIMs and LPMs. Both the CLT or PSM and the LPM-RPs behind each LIM contain relays that can be switched individually by means of software. Software commands entered directly from the TAOS command-line interface or generated by SNMP commands control the operation of the relays.

System operation

In normal operation, each loop connected to an LPM port is connected directly to the port on the LIM in front of or next to the LPM-RP. Using a software command, you can connect a particular loop to the input of the internal or external test head instead of the LIM. If a CLT is used, connection is usually made to the internal test head. When a PSM is installed, the loop is connected to the external terminals on the PSM.

Connections between a particular loop and the test head can be made in two ways. In *looking-out* mode, the loop is disconnected from its LIM and connected only to the test

head input. Looking-out mode is usually used to prequalify lines before they have been put in service. The black path in Figure 1-1 illustrates looking-out mode.

In *bridged* mode, the loop is connected to both the test head and the corresponding port on the LIM. For the Stinger FS or Stinger FS+, bridged mode can be used only if a redundant LIM of the same type is installed in front of the CLT module or PSM. For the Stinger LS or RT bridged mode can be used with active LIMs. The gray path in Figure 1-1 illustrates bridged mode.

Figure 1-1. CLT system

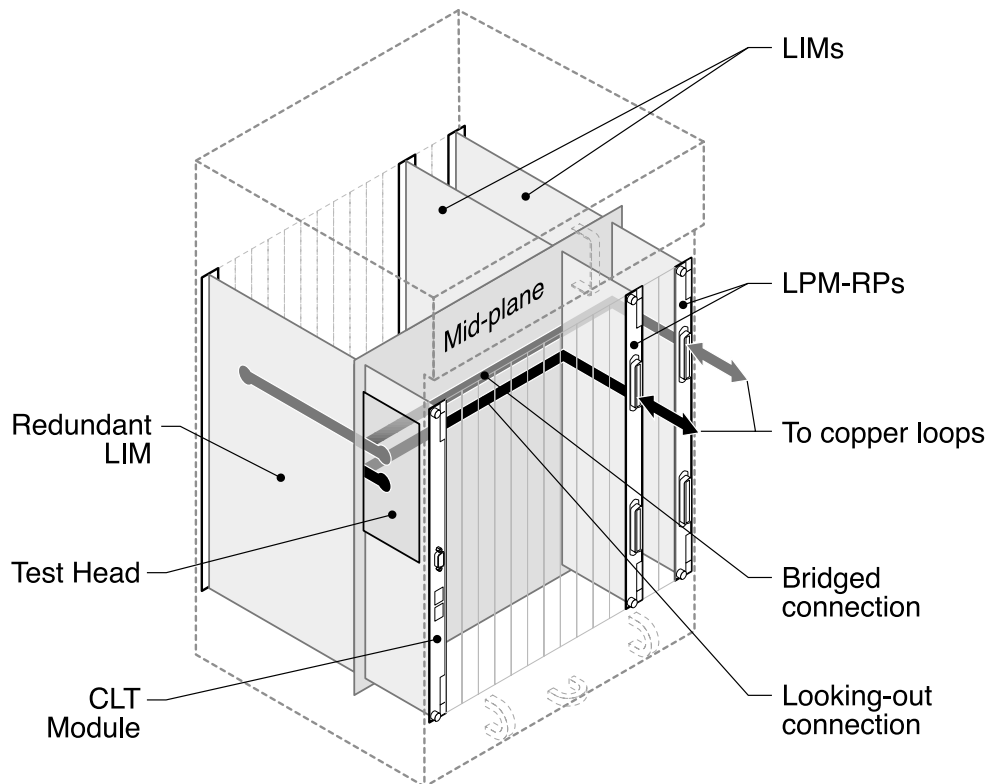

Supported tests

The CLT module supports the following copper loop tests:

- Digital multimeter (DMM) tests
- Line tests
- Time-domain reflectometry (TDR) tests
- Additional functions and commands

DMM tests

DMM tests include measurement of dc and ac voltage, resistance, and capacitance. All tests can be performed between tip and ring, tip and ground, and ring and ground.

dc voltage

Measurement of dc voltage is used for unwanted (foreign) voltage detection. The measurement range is ± 275 volts dc (Vdc).

ac voltage

Measurement of ac voltage is used for foreign voltage detection. The measurements up to 200 volts ac root mean square (Vac rms) can be made.

dc resistance

Measurement of dc resistance is used to detect shorts and leakage between tip and ring, tip and ground, and ring and ground. The measurement range is 1 ohm to 5 megohms (Mohms).

Capacitance

Capacitance measurement is primarily used for loop length estimation. This test report both the actual capacitance and the estimated length. Length estimation is calculated using the ANSI estimation factor of 83 nanofarads (nF) per mile and is reported in feet or meters. The measurement range is 1nF to 1 microfarad (μ F).

Digital multimeter (DMM) dc delta measurement

This test measures loop resistance based on a dc Thevenin circuit. Tests are simultaneously made tip to ring (T-R), tip to shield (T-S), and ring to shield (R-S).

DMM ac delta measurement (CLTE module only)

This test measures loop resistance and capacitance based on an ac Thevenin circuit. Tests are simultaneously made tip to ring (T-R), tip to shield (T-S), and ring to shield (R-S).

DMM longitudinal balance (CLTE module only)

This test measures the longitudinal balance of the loop. This is a measure of how susceptible the line is to noise. Measurement of greater than 60dB indicate a good line.

DMM capacitance equivalent measurement

This test measures loop capacitance tip to ring (T-R), tip to shield (T-S), and ring to shield (R-S) simultaneously.

All-DMM measurement

This test makes tip to ring (T-R), tip to shield (T-S), and ring to shield (R-S) DMM measurements for a selected DMM function with one command.

Line tests

Line tests include noise measurements, insertion loss, coil detection, loop resistance, bridge-tap measurement, first coil location, and short-circuit location. The following sections describe the available line tests.

Wideband noise

The wideband noise test detects interferers from such sources as other digital services, AM radio or electrical equipment. The noise is measured using the Power Spectral Density (PSD) technique.

You test inactive lines after specifying the termination resistance to be placed on the received signal. Line termination can be set to either 100 or 135 ohms. A 100-ohm value is used for testing asymmetric digital subscriber (ADSL) lines, and 135 ohms is used for all other xDSL types.

Active lines are tested in a high-impedance mode that protects the live signal. When using high-impedance mode, you must set the termination mode to either Bridge 100 or Bridge 135. Bridge 100 is used for ADSL lines, and Bridge 135 is used for all other xDSL types. This setting allows the proper power levels to be computed from the received voltage.

Noise can be measured for four different frequency spectrums:

- PSD—measures the noise in the full ADSL discrete multitone (DMT)/CAP spectrum of 22 kilohertz (kHz) to 1.6 megahertz (MHz). Test results are available as 371 pairs of frequency and amplitude data points over the frequency range. Amplitude is specified in decibels referred to 1 milliwatt per hertz. (dBm/Hz).
- E—measures the aggregated noise in the ISDN Basic Rate Interface (BRI) spectrum at an impedance of 135 ohms. The frequency range is 1kHz to 50kHz. Test results are available as a single data point in dBm.
- F—measures the aggregated noise in the high-bit-rate DSL (HDSL) spectrum at an impedance of 135 ohms. The frequency range is 5kHz to 245kHz. Test results are available as a single data point in dBm.
- G—measures the aggregated noise in the ADSL spectrum at an impedance of 100 ohms. The frequency range is 20kHz to 1.1MHz. Test results are available as a single data point in dBm.

Impulse noise

The impulse noise measurement determines whether a loop is susceptible to any spurious impulse-noise spikes during a long period of time. The measurement duration can be anywhere from a few minutes to a few days. The test detects impulse

noise spikes on the signal and keeps a running count of the number of events over time.

Impulse events are divided in three categories. The Low count tallies the number of spikes between Threshold and Threshold + Delta. The Mid count reports the number of spikes with a level between Threshold + Delta and Threshold + 2Delta. The High count reports the number of spikes exceeding a level of Threshold + 2Delta.

Threshold can be specified over a range of 50dBm to 102dBm. Delta can be specified over a range of 2dB to 6dB.

Three other parameters are specified for the impulse test.

- Max Count is the maximum number of impulse events that are counted during a single measurement. Max Count can be specified over a range of 1 to 9999.
- Dead Time is the measurement delay after the unit detects the initial impulse. Dead Time starts when the noise spike is detected. The impulse noise test resumes measuring events after the Dead Time period has elapsed. This prevents the noise test from counting the same spike multiple times.
- Timer specifies the duration of the impulse noise test. Timer can be specified over a range of 1 to 9999 minutes. You can specify a continuous test by setting the value of Timer to continuous.

Coil detection

The load coil detection test detects the presence and number of load coils in the loop. Up to five load coils can be detected. The distance to the first detected load coil can then be measured using a TDR test. After the first coil has been located and physically removed with the help of TDR testing, the coil detection test must be repeated to detect any additional coils.

First coil location

This test measures the distance to the first load coil in the loop.

Short-circuit location

This test measures the distance to a short circuit in the loop.

Bridge-tap measurement

This test detects the number of bridge taps, bridge-tap length, and location.

Detaptor test (CLTE module only)

This is a two ended test to detect the longest bridge tap in the loop. The result shows the length of the longest tap.

Splitter detection

This test detects the presence of a splitter in the loop.

Insertion loss

The insertion loss test is a “paired” test requiring both the CLT module at the CO end and a test unit at the CPE end of the loop. The unit at the CPE end *must* be a SunSet

xDSL model SS160 copper loop test unit manufactured by Sunrise Telcom of San Jose, CA.

The insertion loss test measures the loss characteristics over a range of 13kHz to 1.6MHz. This covers the entire ADSL band. Test results are available as 371 pairs of frequency and signal loss data points over the frequency range. Frequency is specified in kilohertz, and loss is specified in decibels.

Signal-to-noise ratio (SNR)

The signal-to-noise ratio (SNR) test is also a paired test requiring both the CLT module at the CO end and a SunSet test unit at the CPE end of the loop. The test independently measures the best achievable signal-to-noise performance over the full range of frequencies used by DSL modems. The test results correlate to the SNR measurements used by DMT modems to adjust bit distribution and transmit power levels. It is particularly useful to identify frequencies that have low noise margins.

The SNR test measures noise in the 22kHz-to-1.6Mhz spectrum. Test results are available as 367 pairs of frequency and SNR data points over the frequency range. Frequency is specified in kilohertz, and SNR is specified in decibels.

The SNR test depends on an insertion loss measurement. An insertion loss test must be performed first, immediately followed by the SNR test.

Loop resistance

The loop resistance test measures the resistance of the loop. You *must* short-circuit the loop at the CPE end to perform this measurement. You can short-circuit the loop manually or, if a SunSet test unit is available at the CPE end, you can enter commands to short-circuit the loop.

Loop resistance can be used to estimate loop length. Loop length is calculated based on cable gauge and temperature. The resistance measurement can also be used to verify that the circuit has an acceptable loop resistance.

You must specify the temperature before performing this test. Test results are reported in ohms, and estimated length in feet or centimeters. Length estimates are supplied for 22 American wire gauge (AWG), 24 AWG, and 26 AWG, or 0.6mm, 0.5mm, and 0.4mm wire sizes.

TDR tests

Time-domain reflectometry (TDR) operates by sending a pulse of energy down the copper loop. It then measures any reflections or echoes that return to the receiver. These reflections are caused by faults or changes in impedance of the loop. By measuring the time it takes for the reflections to be received back, you can compute the distance to the fault.

For example, a load coil behaves like a large increase in impedance. Any major change in the loop's insulation or fill material (like water in the cable) also causes a detectable reflection.

In general, the TDR function of the CLT module can help you do the following:

- Locate bridge taps and indicate not only the presence of a bridge tap but the exact location and the length of the lateral.
- Determine the presence and location of load coils.

- Detect any other circuit faults, such as an open, short, or wet cable.

To perform these functions, you must use external software to analyze the data that the TDR function returns to you.

TDR test parameters

Before you can perform a TDR test, you must select the parameters for the test using the `tldrset` command. Use Table 1-2 to help you determine TDR test parameters.

Table 1-2. TDR test parameters

Parameter	Meaning	Valid values
Unit	Unit of measurement, either English or metric.	English Metric
Gauge	Wire gauge.	English—22AWG, 24AWG, or 26AWG Metric—0.6mm, 0.5mm, or 0.4mm
VP (velocity of propagation)	Speed that the signal travels down the cable. Use the V_p values associated with your particular cable type. This information is available on the cable's specification sheet or from the manufacturer.	40% to 90% of light speed.
AVG (average)	Number of times the test head must send the TDR pulse. If the value is set for greater than 1, the average value of the response to all pulses is used. Lucent recommends that AVG be set to 1 for all testing.	1 through 5.

TDR test modes

TDR testing can be performed in either automatic or manual mode.

- **Automatic**—In automatic mode, the TDR test reports the location of the first fault. Distance and amplitude data point pairs are also reported around the location of the detected fault.
- **Manual**—In manual mode, you specify a starting length and measurement length to test a specific area of the cable. Starting length can be specified over a range of 15 to 20,000 feet (5 to 6096 meters). Measurement length is specified over a range of 100 to 20,000 feet (31 to 6096 meters). For efficient testing, Lucent recommends that measurement lengths of less than 2000 feet (610 meters) be used.

Other functions and commands

Other functions and several maintenance commands are available from the test head. These include test tone sending and receiving, calibration, test head reset, and version reporting and download of test head software.

Send Tone function

Tones of a specified frequency and level can be sent from the test head. Frequency can be specified over a range of 10 to 1600kHz. Levels can be set over a range of -10 to +26dBm.

Send Control Tone function

This function sends control tones for ADSL and G.lite services. Either quiet or restore tones can be sent.

Send Trace Tone function

This function sends trace tones tip to ring (T-R), tip to shield (T-S), and ring to shield (R-S). Power can be specified between -10dBm and 10dBm, with periods ranging from 1 minute to 120 minutes.

Stop Tone function

This function stops the transmission of tones.

Receive Tone function

The frequency and level of a tone on the loop can be measured. Frequency is reported in kilohertz, and level is reported in dBm. The level is measured for the highest power frequency.

Detect Ringer function

This test detects the presence of the ringer signal.

Detect ATU-R function

This test detects the presence of the ADSL transmission unit-remote (ATU-R) signal.

Voice detection

This test detects the presence of voice signals in the loop.

Voice signal detection (CLTE module only)

This test detects and measures various signals on the loop. The signal types include voice, DTMF, MF, tone, background noise and signal to noise.

Send voice signal (CLTE module only)

This test sends voice and tone signals in various modes. The modes include tone, three tone, sweep, DTMF, and female voice.

Dial tone testing and analysis (CLTE module only)

The test will draw, break and analyze the subscriber dial tone.

Splitter bypass

This function controls the bypass mode on programmable splitters. Currently the Intelligent POTS Splitter (iPOTS) manufactured by mPhase Technologies is supported.

Responder mode

This function sets the CLT module to responder mode. In responder mode, the CLT module can be used with a Sunset DSL test set at the CPE end of the loop to perform two-ended testing. Two-ended tests include insertion loss, loop resistance and signal-to-noise ratio measurements.

Calibration command

The Calibration command internally calibrates the measurement circuitry of the test head. Lucent recommends that you perform calibration at the following times:

- Every 30 operation days
- After you enter the Reset command

Reset command

The Reset command restarts the hardware circuitry of the test head.

Version command

The Version command reports the software version of the test head.

Download command

The Download command is used to upgrade the test head software.



Caution Use the Download command only if you are qualified Lucent service personnel or are working under their direction.

How to perform tests

Testing can be initiated by means of either the TAOS command-line interface or SNMP. For more information, see Chapter 2, “Copper Loop Testing through the Command-Line Interface” or Chapter 3, “Copper Loop Testing through SNMP.”

Test results are obtained through the TAOS command-line interface, SNMP, or the TL1 interface.

To run a test, you perform the following three steps:

- 1 Using TAOS command-line interface commands or SNMP, select the copper loop to be tested and activate the test head. (If a PSM and an external test head are used for testing, this is the only step needed.)
- 2 Enter the commands and parameters or SNMP objects necessary to select and characterize the desired test.
- 3 After waiting for the test to finish, access the resulting data using the command-line interface or SNMP, and pass it to external software for analysis.

Copper Loop Testing through the Command-Line Interface



2

Using the command-line interface	2-1
Enabling tester and copper loop access	2-2
Selecting a test	2-6
Determining test results	2-32

The TAOS command-line interface (CLI) can be used to set the parameters for, initiate, and obtain the results of any available copper loop test.

Using the command-line interface

You perform testing either by entering `cl t` commands or by setting parameters in various `cl t` profiles.

Performing tests by entering `cl t` commands

Tests are performed with `cl t` commands as follows:

- 1 Select the loop with the `cl t activate` command.**
See “Enabling test access with the `cl t activate` and `cl t deactivate` commands” on page 2-2.
- 2 Select the test and its parameters with the `cl t cmd` command.**
See “Selecting tests with the `cl t cmd` command” on page 2-7.

The results of the tests are displayed on your terminal.

Performing tests using `cl t` profiles

Perform tests by setting the parameters of `cl t` profiles as follows:

- 1 Select the loop by using the `set` command to set the appropriate parameters in the `CLT-Access` profile.**
When all the parameters have been set, use the `write` command to store the parameters and activate loop access. See “Enabling test access through the `CLT-Access` profile” on page 2-3.
- 2 Set the parameters for the desired test by using the `set` command.**

When all the parameters have been set use the `wri te` command to store the values. See “Selecting tests through the Clt-Command profile” on page 2-22.

3 Use the set command to set the test-operation parameter to select the desired test.

Use the `wri te` command to store the value and start the selected test. See “Selecting tests through the Clt-Command profile” on page 2-22.

4 Monitor the value of the test-result-status parameter in the clt-result profile to determine when the test is completed.

See “Determining test results” on page 2-32.

5 Use the list command to list the clt-result profile and view the test results.

Enabling tester and copper loop access

The first step is to activate tester access by connecting the desired copper loop to the internal test head or to the external test terminals. Perform this step by means of commands or through the `clt-access` profile. If a path selector module (PSM) and an external test head are used, this is the only step needed.

Enabling test access with the `cltActivate` and `cltDeactivate` commands

From the command line, you can enter the `cltactivate` and `cltdeactivate` commands.

`cltActivate` command

Enter this command with the appropriate parameters to connect a copper loop in a LIM to an internal test head or external test terminals.

Usage `cltactivate slot port [cltslot][mode][terminal][loop]`

Syntax element	Description
<code>slot</code>	Slot number of the LIM containing the copper loop to be tested.
<code>port</code>	Port number of the copper loop to be tested.
<code>cltslot</code>	Number of the slot where the CLT module or PSM doing the testing is installed.
<code>mode</code>	Connection configuration of the copper loop: <code>bridged</code> —Copper loop is connected to the test head and the corresponding port of the spare LIM. This is the default value. <code>looking-out</code> —Copper loop is connected only to test head.
<code>terminal</code>	Connection point of the copper loop: <code>internal-tester-terminal</code> —Copper loop is connected to the internal test head of the CLT module. This is the default value. <code>external-tester-terminal</code> —Copper loop is connected to the external test terminals of the CLT module or PSM. <code>auxiliary-tester-terminal</code> —Copper loop is connected to the auxiliary test terminals of the CLT module or PSM.

Syntax element	Description
loop	Copper loop number of the T1 or E1 port. This parameter applies only to copper loops connected to T1 or E1 LIMs and is ignored for all other LIMs. 1—Transmit copper loop. 2—Receive copper loop.

Example

```
admin> cltactivate 2 32 15 bridged internal
LOG notice, Shelf 1, Slot 8, Time: 11:58:49--
LIM 15 IF 32 ACTIVATED as spare for IF 2
```

cltActivate External-Loop command

Enter this command to set the CLT module as a test head for an external loop. This command does not have any parameters. The CLT slot is detected automatically, and the access mode is set to looking-out.

Usage cltActivate external-loop

The `cltActivate external-loop` command is used to allow a Stinger unit with a copper loop test (CLT) module to test copper loops connected to other Stinger units that are equipped with only a path selector module (PSM).

cltDeactivate command

Enter this command without any parameters to deactivate the connection between a copper loop and an internal test head or external test terminals.

Usage cltdeactivate

Example

```
admin> cltdeactivate
LOG notice, Shelf 1, Slot 8, Time: 12:07:51--
LIM 15 IF 32 DEACTIVATED as spare for IF 2
```

Enabling test access through the CLT-Access profile

Tester access can also be activated by means of the TAOS profile `clt-access`. Following are the `clt-access` profile parameters with their default values.

```
[in CLT-ACCESS]
cltm-slot = slot-16
access-slot = slot-16
access-port = 1
access-loop = 1
access-mode = looking-out
access-terminal = internal-tester-terminal
```

Copper Loop Testing through the Command-Line Interface

Enabling tester and copper loop access

```
activate-access = no  
access-result = idle
```

Parameter	Specifies
<code>cltm-slot</code>	Slot number where the CLT module or PSM is installed.
<code>access-slot</code>	Slot number of the LIM containing the copper loop to be tested.
<code>access-port</code>	Port number of the copper loop to be tested.
<code>access-loop</code>	Copper loop number of the T1 or EI port. This parameter applies only to copper loops connected to T1 or E1 LIMs and is ignored for all other LIMs. 1—Transmit copper loop. 2—Receive copper loop.
<code>access-mode</code>	Connection configuration of the copper loop: <code>bridged</code> —Copper loop is connected to the test head and the corresponding port of the spare LIM. <code>looking-out</code> —Copper loop is connected only to the test head. This is the default value.
<code>access-terminal</code>	Connection point of the copper loop: <code>internal-tester-terminal</code> —Copper loop is connected to the internal test head of the CLT module. This is the default value. <code>external-tester-terminal</code> —Copper loop is connected to the external test terminals of the CLT module or PSM. <code>auxiliary-tester-terminal</code> —Copper loop is connected to the auxiliary test terminals of the CLT module or PSM. <code>external-loop</code> —Internal test head of CLT module is connected to the TEST PAIR connector of the CLT module.
<code>activate-access</code>	Activates tester connection to the copper loop. <code>yes</code> —Copper loop is connected as specified. <code>no</code> —Copper loop is disconnected from test head or test terminals
<code>access-result</code>	Result of tester connection to the copper loop. This value is updated by the system after changes to the profile have been written. <code>idle</code> —Test head is inactive and no copper loops are connected. <code>access-activated</code> —Test head is active and copper loop is connected as specified. <code>resource-busy</code> —The resource to enable CLT module access is in use. Access failed.

Example using CLT-Access

In the following example, the administrator lists the `clt-access` profile, sets some of its parameters to new values to activate testing, and saves and lists the changes:

```
admin> read clt-access
CLT-ACCESS read

admin> list
[in CLT-ACCESS]
cltm-slot = slot-16
access-slot = slot-16
access-port = 1
access-mode = looking-out
access-terminal = internal-tester-terminal
activate-access = no
access-result = idle

admin> set cltm-slot = 15
admin> set access-slot = 2
admin> set access-port = 32
admin> set access-mode = bridged

admin> set activate-access = yes
admin> write

LOG notice, Shelf 1, Slot 8, Time: 15:54:08--
LIM 15 IF 32 ACTIVATED as spare for IF 2

admin> read clt-a
CLT-ACCESS read

admin> list
[in CLT-ACCESS]
cltm-slot = slot-15
access-slot = slot-2
access-port = 32
access-mode = bridged
access-terminal = internal-tester-terminal
activate-access = yes
access-result = access-activated
```

Enabling loop testing with one CLT module and multiple Stinger units

Several PSM-equipped Stinger units can be served by one Stinger unit equipped with a CLT module. To use this method, connect the tip, ring, and ground connections of the TEST PAIR connectors on the PSMs to the TEST PAIR connector on the CLT module, using either a daisy-chain or star configuration.

Then, by using the `cltactivate` command or by modifying the `clt-access` profile for the appropriate Stinger unit, proceed as follows:

- 1 Select the loop to be tested on the appropriate Stinger unit and set the access terminal on that unit to external-tester-terminal**
- 2 Set the access terminal for the Stinger unit containing the CLT module to external-loop.**

See “Sample two-unit configuration” on page 2-6 for configuration examples.

Sample two-unit configuration

A system is set up with two Stinger units. Stinger 1 is configured with a PSM in slot 12 and ADSL LIMs in slots 1 through 7. Stinger 2 is equipped with a CLT module in slot 16. You want to perform loop tests on the loop connected to port 7 of the ADSL LIM in slot 2 of Stinger 1.

Example using the `cltActivate` command

- 1 Connect tip, ring, and ground connection of the TEST PAIR connector on the PSM in Stinger 1 to the respective tip, ring, and ground connections of the TEST PAIR connector on the CLT module in Stinger 2.**
- 2 Enter the `cltactivate` command for Stinger 1 as follows:**
`admin> cltactivate 2 7 12 looking-out external-tester-terminal`
- 3 Enter the `cltactivate` command for Stinger 2 as follows:**
`admin> cltactivate external-loop`
- 4 Proceed with the desired test selection and result collection commands on Stinger 2.**

Example using the `ClT-Access` profile

- 1 Connect the tip, ring, and ground connection of the TEST PAIR connector on the PSM in Stinger 1 to the respective tip, ring, and ground connections of the TEST PAIR connector on the CLT module in Stinger 2.**
- 2 Write to the `clt-access` profile for Stinger 1 as follows:**
`admin> read clt-access`
`CLT-ACCESS read`
`admin> set cltm-slot = 12`
`admin> set access-slot = 2`
`admin> set access-port = 7`
`admin> set access-terminal = external-tester-terminal`
`admin> set activate-access = yes`
`admin> write`
- 3 Write to the `clt-access` profile for Stinger 2 as follows:**
`admin> read clt-access`
`CLT-ACCESS read`
`admin> set access-terminal = external-loop`
`admin> set activate-access = yes`
`admin> write`
- 4 Configure the `clt-command` and `clt-results` profiles for the desired tests on Stinger 2.**

Selecting a test

The next step is to select the desired copper loop test and specify its parameters. You can do so by using the `cltcmd` command or the `clt-command` profile.

Selecting tests with the `cltCmd` command

From the command line, you enter the `cltcmd` command plus the appropriate parameter to activate a copper loop test.

Enter the `cltcmd` command and supply the test name and any relevant parameters.

Usage `cltcmd test [parameter 1] [parameter 2] [parameter n]`

Syntax element	Description
<code>test</code>	Type of copper loop test, test setup, or maintenance action to perform. The following are valid values:
<code>bgns</code>	Runs a background noise test. You must run the <code>calib</code> command before performing this test.
<code>btap</code>	Detects the number of bridge taps, their length and location.
<code>calib</code>	Internally calibrates the measurement circuitry of the test head. Use the <code>cltcmd calib</code> command after every 30 days of CLT module use and after entering the <code>cltcmd reset</code> command.
<code>cldet</code>	Runs a coil detection test.
<code>cpemdm</code>	Detects an ATU-R signal.
<code>ctonesnd</code>	Sends a control tone of a specified type and service for DSL modems.
<code>detaptor</code>	Detaptor test (applies to CLTE module only).
<code>dnld</code>	Downloads software upgrades to the test head.
<code>dmm</code>	Runs a digital multimeter (DMM) measurement test.
<code>dmmacd</code>	Runs a DMM ac delta measurement test (applies to CLTE module only).
<code>dmmal1</code>	Runs the selected DMM test, tip to ring (T-R), tip to shield (T-S), and ring to shield (R-S) simultaneously.
<code>dmmcap</code>	Runs a DMM capacitance equivalent test.
<code>dmmcd</code>	Runs a DMM dc delta measurement test.
<code>dmm1bal</code>	Runs a DMM longitudinal balance test (applies to CLTE module only).
<code>dta</code>	Draw, break and analyze subscriber dial tone (applies to CLTE module only).
<code>flloc</code>	Measures the distance to the first load coil.
<code>impread</code>	Reads the impulse noise test result.
<code>impstart</code>	Starts the impulse noise test.
<code>impstop</code>	Stops the impulse noise test.
<code>inls</code>	Runs an insertion loss test. This test requires the presence of an additional test set at the CPE end of the loop.

Syntax element	Description
lpres	Runs a loop resistance test. The CPE end must be shorted or connected to an xDSL test set.
measvoice	Voice signal or narrow band tone detection (applies to CLTE module only).
reset	Resets the test head module.
rngr	Detects the presence of a ringer.
setbypass	Places an mPhase iPOTS splitter in bypass mode.
setresp	Places the CLT module in responder mode.
shortloc	Measures the distance to a short circuit in the loop.
signs	Runs a signal-to-noise test. This test requires the presence of an additional test set at the CPE end of the loop.
sndvoice	Send voice signal (applies to CLTE module only).
splitter	Detects the presence of a splitter in the loop circuit.
tdr	Runs a TDR test. You must run the tdrset command before running this test.
tdrset	Sets time-domain reflectometry (TDR) test parameters.
tonercv	Measures the frequency (kilohertz) and level (dBm) of tones received on the copper loop.
tonesnd	Sends a tone of the specified frequency (kilohertz) and level (dBm) from the test head.
tstop	Stops sending of tones.
ttonesnd	Sends a trace tone of 577.5Hz over selected pair at a specified power and duration.
vers	Displays the version of the hardware and software running on the internal test head.
voicedet	Detects the presence of voice signals on the loop.
parameter	See the following sections for any necessary parameters.

Example To measure tone frequency and level:

```
admin> cltcmd tonercv  
Tone frequency 640KHz, Level -2 0.01dBm
```

To reset the test head:

```
admin> cltcmd reset  
CLT module POST successful.
```

cltcmd bgns

Description Runs a background noise test.

Usage `cltcmd bgns [psd|e|f|g] [term100|term135|bridge100|bridge135]`

Option	Description
psd	Measures power spectral density in a 22kHz-to-1.6MHz range.
e	Reports one noise value at 135-ohm impedance for a 1kHz-to-50kHz range. Used for ISDN qualification.
f	Reports one value for a 5kHz-to-245kHz range. Used for HDSL qualification.
g	Reports one noise value at 100-ohm impedance for a 10kHz-to-1.1Mhz range. Used for ADSL qualification
term100	Places a 100-ohm termination on the received signal.
term135	Places a 135-ohm termination on the received signal.
bridge100	Puts the receiver in high-impedance mode, and calculates the noise signal based on 100-ohm impedance.
bridge135	Puts the receiver in high-impedance mode, and calculates the noise signal based on 135-ohm impedance.

Example `admin> cltcmd bgns e term135`

cltcmd btap

Description Detects up to one bridge-taps, bridge-tap length, and location.

Usage `cltcmd btap start length`

Option	Description
start	Starting location for bridge-tap search. Range is 15 to 20000 feet if TDR units is set to ENGLISH. Range is 5 to 6097 meters if TDR units is set to METRIC.
length	Loop length for bridge tap search. Range is 100 to 20000 feet if TDR units is set to ENGLISH. Range is 32 to 6097 meters if TDR units is set to METRIC.

Example `admin> cltcmd btap 100 1000`

Number of bridge taps = 0, Loop length = 284

CLT operation completed.

cltcmd cpendm

Description Detects an ATU-R signal (ADSL LIMs only).

Usage `cltcmd cpendm`

Example

```
admin> cltcmd cpendm
CPE detected: NO
CLT operation completed.
```

cltcmd ctonesnd

Description Sends an xDSL control tone.

Usage `cltcmd ctonesnd adsl | glite quiet | restore`

Option	Description
adsl	Set for ADSL service.
glite	Set for G.lite service.
quiet	Send quiet tone.
restore	Send restore tone.

Example

```
admin> cltcmd ctonesnd adsl quiet
CLT operation completed.
```

cltcmd detaptor

Description Runs a two ended test to detect the longest bridge tap in the copper loop (applies to CLTE module only).

Usage `cltcmd detaptor <metric|english> Vp (0 - 99 V)`

Option	Description
metric	Set units for length to metric.
english	Set units for length to English.
vp	Set peak voltage. Range is from 0 to 99 volts

Example admin> `cltcmd detaptor metric 50`
admin>

No. of taps detected are 2 and tap length is 20000 in cm
CLT operation completed.

cltcmd dmm

Description Runs a digital multimeter (DMM) measurement test.

Usage `cltcmd dmm [ohm|dcv|acv|cap] [t-r|t-s|r-s]`

Option	Description
ohm	Resistance test
dcv	dc voltage test
acv	ac voltage test
cap	Capacitance test
t-r	Measure between tip and ring.
t-s	Measure between tip and sleeve (ground).
r-s	Measure between ring and sleeve (ground).

Example `admin> cltcmd dmm dcv t-r`

cltcmd ctonesnd

Description Sends an xDSL control tone.

Usage `cltcmd ctonesnd adsl | glite quiet | restore`

Option	Description
adsl	Set for ADSL service.
glite	Set for G.lite service.
quiet	Send quiet tone.
restore	Send restore tone.

Example

`admin> cltcmd ctonesnd adsl quiet`
CLT operation completed.

cltcmd dmmacd

Description Runs a DMM ac delta test (applies to CLTE module only).

Usage `cltcmd dmmacd time voltage frequency`

Option	Description
time	Settling time. Select 0 to 5 tenths (.1) of seconds.
voltage	Test voltage. Select 1 to 24 volts RMS.
frequency	Output frequency. Select output frequency from 20Hz to 2000Hz.

Example admin> **cltcmd dmmacd 2 12 1200**

admin>
Capacitance (T-R) 368 (T-S) 210 (R-S) 197 pF
Resistance (T-R) 14534 (T-S) 188872 (R-S) 191260 Ohm

cltcmd dmmall

Description Runs a selected DMM test on tip to ring (T-R), tip to shield (T-S), and ring to shield (R-S).

Usage **cltcmd dmmall type time input impedance**

Option	Description
type	ohm—Resistance test dcv—dc voltage test acv—ac voltage test
time	0 to 5 tenths (0.1) second
input impedance	100 or 1000 Kohm

Example

admin> **cltcmd dmmall ohm 1 100**
Resistance (T-R) 123 (T-S) 74 (R-S) 340 Ohm
CLT operation completed.

cltcmd dmmcap

Description Runs a DMM capacitance equivalent measurement.

Usage **cltcmd dmmcap time**

Option	Description
time	0 to 5 tenths (0.1) second

Example

admin > **cltcmd dmmcap 1**
Capacitance (T-R) 150, (T-S) 64, (R-S) 64 pF
CLT operation completed.

cltcmd dmmddc

Description Runs a DMM dc delta measurement.

Usage `cltcmd dmmlcd time voltage output impedance`

Option	Description
<code>time</code>	0 to 5 tenths (0.1) second
<code>voltage</code>	-230 to 230 V
<code>output impedance</code>	10 to 1000 Kohm

Example

```
admin> cltcmd dmmlcd 1 10 10
Resistance (T-R) 123 (T-S) 123 (R-S) 123 Ohm
DC Voltage (T-S) 76 (R-S) 48 mV
CLT operation completed.
```

cltcmd dmmlbal

Description Runs a DMM longitudinal balance test (applies to CLTE module only).

Usage `cltcmd dmmlbal time voltage frequency`

Option	Description
<code>time</code>	Settling time. Select 0 to 5 tenths (.1) of seconds.
<code>voltage</code>	Test voltage. Select 1 to 24 volts RMS.
<code>frequency</code>	Output frequency. Select output frequency from 20Hz to 2000Hz.

Example `admin> cltcmd dmmlbal 3 12 1900`
`admin>`
Longitudinal Balance 29 in db
CLT operation completed

cltcmd dta

Description Draw, break, and analyze subscriber dial tone (applies to CLTE module only).

Usage `cltcmd dta <term/dtmf>`

Option	Description
<code>term</code>	Remove bridge to create dial tone break.
<code>dtmf</code>	Use DTMF tone to create dial tone break.

Example admin> **cltcmd dta dtmf**

admin>

The Result Obtained is DTA: Cannot Draw

CLT operation completed.

cltcmd fclloc

Description Runs a test to measure the distance to the first load coil in a copper loop.

Usage **cltcmd fclloc metric|english gauge**

Option	Description
metric	Uses metric units for test parameters and results.
english	Uses English units for test parameters and results.
gauge	Gauge of the cable in the loop, one of the following <ul style="list-style-type: none"> ■ In English units, 22 AWG, 24 AWG, or 26 AWG ■ In metric units, 4, 5, or 6 tenths of a millimeter

Example To measure the distance in centimeters to the first load coil in a 0.04mm loop:

admin> **cltcmd fclloc metric 4**

admin>

First Coil Location: 9750 cm

CLT operation completed.

cltcmd inpread

Description Reads and displays the impulse noise test result.

Usage **cltcmd inpread**

cltcmd impstart

Description Starts the impulse noise test.

Usage **cltcmd impstart threshold delta max-count dead-time timer**

Option	Description
threshold	Threshold value of the smallest noise spike detected, a value within the range 50 through 100dBm.
delta	Delta—the number of decibels referred to 1mW (dBm) above the threshold—to measure for noise spike detection, a value within the range 2 through 6dBm.
max-count	Maximum number of impulse events to be counted during a single measurement, a value from 1 through 9999.

Option	Description
dead-time	Measurement delay after the unit detects the initial impulse, a value from 10 through 250 tenths (0.1) of a millisecond (ms).
time	Duration of noise measurement, a value from 1 through 9999 minutes.

Example admin> cltcmd impstart 70 4 5000 500 20

cltcmd impstop

Description Stops the impulse noise test.

Usage admin> cltcmd impstop

Example admin> cltcmd impstop

admin>

CLT operation completed.

cltcmd inls

Description Runs the insertion loss test. An additional test set at the CPE end of the loop must be present.

Usage cltcmd inls

Example admin> CLTCMD INLS

admin>

Frequency 30 Khz, Loss 200 0.01dBm

Indicates out of range result

CLT operation completed.

cltCmd lpres

Description Runs a loop resistance test. This test requires that the loop be shorted at the CPE end of the loop.

Usage cltcmd lpres [english|metric] temp

Option	Description
english	Use English units for test parameters and results.
metric	Use metric units for test parameters and results.
temp	Temperature of the loop, a value within either of the following ranges: <ul style="list-style-type: none"> ■ In English units, from 0 through 200 degrees F ■ In metric units, from -178 through 933 degrees C, in tenths (0.1) of a degree

cltcmd measvoice

Description Detects and measures voice, tone or signal noise ratio on the copper loop (applies to CLTE module only).

Usage There are three available test methods:

cltcmd measvoice *auto/dtmf/mf p*

Option	Description
auto	Auto mode detects if voice signal is present on the loop.
dtmf	DTMF mode detects if DTMF tones exist on the loop.
mf	MF mode detects if MF tones exist on the loop.
p	Select a detection period between 1 and 20 seconds.

cltcmd measvoice *bgns cmsg/3kflat*

Option	Description
bgns	Specifies background noise test.
cmsg	Specifies C-message filter for noise test.
3kflat	Specifies 3-Kflat filter for noise test.

cltcmd measvoice *tone/sdns*

Option	Description
tone	Specifies tone mode. Detects a single tone.
sdns	Specifies signal to noise mode. Measures signal to noise using a C-notch filter.

Example admin> **cltcmd measvoice auto 1**
Voice signal not detected

CLT operation completed.

cltcmd reset

Description Resets the CLT test head.

Usage **cltcmd reset**

Example admin> **cltcmd reset**
admin>
CLT module POST successful.

Software revision 106, Hardware revision 52

CLT operation completed.

cltcmd rngr

Description Detects the presence of a ringer.

Usage `cltcmd rngr`

admin> **cltcmd rngr**

Ringer detected: NO

CLT operation completed.

cltcmd setbypass

Description Toggles an mPhase iPOTS splitter in and out of bypass mode.

Usage `cltcmd setbypass`

Example admin > **cltcmd setbypass**

CLT operation completed

Dependencies Successive instances of this command toggle the splitter bypass mode from off to on and back.

cltcmd setresp

Description Puts the CLT module in responder mode.

Usage `cltcmd setresp on/off time`

Option	Description
on	CLT responder mode is on.
off	CLT responder mode is off.
time	1 to 999 minutes. Valid only when responder mode is on.

Example admin > **setresp on 15**

cltcmd shortloc

Description Runs a test to measure the distance to a short circuit in a copper loop.

Usage `cltcmd shortloc metric/english gauge detect | nodetect`

Option	Description
<code>metric</code>	Uses metric units for test parameters and results.
<code>english</code>	Uses English units for test parameters and results.
<code>gauge</code>	Gauge of the cable in the loop, one of the following <ul style="list-style-type: none">■ In English units, 22 AWG, 24 AWG, or 26 AWG■ In metric units, 4, 5, or 6 tenths of a millimeter
<code>detect</code>	Detects the short with a DMM test and then measures its location.
<code>nodetect</code>	Measures the distance to a short circuit without a DMM test.

Example To detect a short circuit in a 24AWG copper loop and measure the distance to it in feet:

```
admin> cltcmd shortloc english 24 detect
admin>
Short Location: 134117 0.01 ft.
CLT operation completed.
```

cltcmd signs

Description Runs signal to noise test. This test requires the presence of an additional test set at the CPE end of the copper loop.

Usage `cltcmd signs`

cltcmd sndvoice

Description Sends actual voice or tone signals on the copper loop in various modes (applies to CLTE module only).

Usage There are five different modes that can be used:

For tone mode: `cltcmd sndvoice tone frequency level time`

Option	Description
<code>tone</code>	Selects single tone mode.
<code>frequency</code>	Specify a tone frequency in a range of 300Hz to 4000Hz.
<code>level</code>	Specify a tone level in a range of -30dBm to 10dBm.
<code>time</code>	Specify the total duration of the tone in a range of 1 to 120 minutes.

For 3 tone mode: **cltcmd sndvoice 3-tone level period time**

Option	Description
3-tone	Selects 3 tone mode. Three single frequency tones are sent at frequencies of 404Hz, 1004Hz, and 2804Hz.
level	Specify a tone level in a range of -30dBm to 10dBm.
period	Specify the length of each individual tone in a range of 1 to 10 seconds.
time	Specify a total duration in a range of 1 to 120 minutes.

For sweep mode: **cltcmd sndvoice sweep start end increment level period**

Option	Description
sweep	Selects sweep mode.
start	Specify the starting frequency in a range of 300Hz to 20000Hz.
end	Specify the ending frequency in a range of 300Hz to 20000Hz.
increment	Specify the frequency increment for each successive tone in a range of 10Hz to 1000Hz.
level	Specify a tone level in a range of -30dBm to 10dBm.
period	Specify the length of each tone in a range of 1 to 10 seconds.

For send voice mode: **cltcmd sndvoice dtmf/mf string**

Option	Description
dtmf	Specifies that DTMF tones are sent.
mf	Specifies that MF tones are sent
string	An ASCII string of up to 20 digits to be sent as tones.

For digit mode: **cltcmd sndvoice digit string**

Option	Description
digit	Specifies digit mode where each digit is sent in a female voice.
string	An ASCII string of up to 20 digits with values from 0 to 9.

Example admin> **cltcmd sndvoice tone 450 2 1**
admin>

cltcmd splitter

Description Detects the presence of a splitter in the copper loop circuit.

Usage **cltcmd splitter**

Example admin > **cltcmd splitter**

Splitter detected : YES
CLT operation completed

cltcmd tdr

Description Runs a TDR test

Usage **cltcmd tdr** [*auto/manual*] *start length*

Option	Description
auto	Runs the test automatically so that the first fault is automatically detected.
manual	Runs the test manually and requires a measurement range.
start	For manual mode, the distance at which to start TDR measurement, a value in one of the following ranges: <ul style="list-style-type: none">■ In English units, from 15 through 20,000 feet■ In metric units, from 5 through 6097 meters
length	For manual mode, the total length of the measurement starting from <i>start</i> , a value in one of the following ranges: <ul style="list-style-type: none">■ In English units, from 100 through 20,000 feet. The sum of <i>start</i> and <i>length</i> must not exceed 20,000 feet.■ In metric units, from 32 through 6097 meters. The sum of <i>start</i> and <i>length</i> must not exceed 6097 meters.

Example admin> **cltcmd tdr manual 5000 12000**

cltcmd tdrset

Description Sets time-domain reflectometry (TDR) test parameters.

Usage **cltcmd tdrset** *metric/english gauge Vp tries*

Option	Description
metric	Use metric units for test parameters and results.
english	Use English units for test parameters and results.

Option	Description
gauge	Gauge of the cable in the loop, one of the following values: <ul style="list-style-type: none">■ In English units, 22AWG, 24AWG, or 26AWG■ In metric units, 4, 5, or 6 tenths of a millimeter.
Vp	Velocity of propagation for the cable under test, a value from 40% through 90% of the speed of light.
tries	Number of times the TDR pulse is sent, a value from 1 through 5 pulses. Results are averaged if more than one pulse is used.

Example `admin> cltcmd tdrset metric 5 85 3`

cltcmd tonesend

Description Sends a tone of the specified frequency (kilohertz), level (dBm), and period from the test head.

Usage `cltcmd tonesnd frequency power period`

Option	Description
frequency	Frequency of the tone sent, a value from 10 through 1600kHz.
power	Amplitude of the tone sent, a value from -10 through 10dBm.
period	1 to 120 minutes (default is 60 minutes)

Example `admin> cltcmd tonesnd 640 -2 75`

cltcmd ttonesend

Description Sends a trace tone.

Usage `cltcmd ttonesend type power period`

Option	Description
type	T-R—Send tip to ring. T-S—Send tip to sleeve. R-S—Send ring to sleeve.
power	-10dBm to 10 dBm
period	1 to 120 minutes (default is 60 minutes)

Example

`admin> cltcmd ttonesnd t-s 5 30`

CLT operation completed

cltcmd tstop

Description Stops sending tones.

Usage **cltcmd tstop**

Example

```
admin> cltcmd tstop  
CLT operation completed
```

cltcmd vers

Description Displays the hardware and software version of the CLT test head.

Usage **cltcmd vers**

Example admin> **cltcmd vers**

```
admin>  
Software revision 106, Hardware revision 52  
CLT operation completed.
```

cltcmd voicedet

Description Runs a test to detect the presence of voice signals in a copper loop.

Usage **cltcmd voicedet**

Example

```
admin> cltcmd voicedet  
admin>  
Voice signal not detected  
CLT operation completed.
```

Selecting tests through the Clt-Command profile

Use the `clt-command` profile to select and set parameters for tests. Set the test parameters for the desired test using the `set` command. Use the `write` command to store the values you have set.

The type of test is defined by the `test-operation` parameter. Any change in this parameter initiates the test identified by the new value of this parameter. Be sure to set the value of the `test-operation` parameter *after* all the other parameter relevant to that test have been set.

Following are the `clt-command` parameters with their default values.

```
[in CLT-COMMAND]  
cltm-slot = slot-16  
test-time-stamp = 0  
test-sequence = 0  
test-operation = none
```

```
dmm-type = resistance
dmm-lead = tip-ring
background-noise-filter = psd
background-noise-termination = term100
loop-resistance-unit = metric
loop-resistance-temp = 0
impulse-noise-start-thresh = 50
impulse-noise-start-delta = 2
impulse-noise-start-max-count = 1
impulse-noise-start-dead-time = 1
impulse-noise-start-timer = 1
calibration-type = insertion-loss
tone-send-freq = 10
tone-send-level = 0
tone-send-period = 0
tdr-unit = metric
tdr-gauge = 0
tdr-vp = 0
tdr-avg = 1
tdr-get-type = automatic
tdr-start-distance = 0
tdr-measurement-length = 0
dmmcd-period = 0
dmmcd-voltage = 0
dmmcd-impedance = 1
dmmcap-period = 0
dmmall-type = resistance
dmmall-period = 0
dmmall-input-imp = 0
ctone-type = adsl
ctone-tone = quiet
ttone-lead = tip-ring
ttone-level = 0
ttone-period = 0
btap-start-length = 0
btap-measure-length = 0
fclloc-unit = metric
fclloc-gauge = 0
shortloc-unit = metric
shortloc-gauge = 0
shortloc-type = detect
setresp-mode = on
setresp-mode-period = 0
dmmacd-period = 0
dmmacd-voltage = 0
dmmacd-frequency = 0
dmmalbal-period = 0
dmmalbal-voltage = 0
dmmalbal-frequency = 0
dmmsoak-voltage = 10
dmmsoak-configuration = t-s
dmmsoak-resistance = 1
```

```
dmsoak-no-of-samples = 0
dmsoak-interval = 0
sendvoice-op-mode = tone
sendvoice-frequency = 0
sendvoice-decibal-level = 0
sendvoice-time-duration = 0
sendvoice-tone-period = 0
sendvoice-start-freq = 0
sendvoice-end-freq = 0
sendvoice-freq-increase = 0
sendvoice-dtmf-mf-tone = ""
sendvoice-digit-string = 0
detap-unit = metric
detap-voltage = 0
measvoice-opmode = auto
measvoice-det-period = 0
measvoice-bgns-mode = msg
```

Parameter	Setting
cltm-slot	Number of the slot where the CLT module or PSM is installed.
test-time-stamp	Value of the sysUpTime when the last test command was issued. This parameter is cleared when any of the test parameters are changed.
test-sequence	Sequence of the last issued test command.

Parameter	Setting
test-operation	Type of test to run: none No test. dmm-test—Starts digital multimeter (DMM) tests. line-inls-test—Starts an insertion loss test. line-bgns-test—Starts a background noise test. line-signs-test—Starts a signal-to-noise test. line-lpres-test—Starts a loop resistance test. line-cldet-test—Starts a load coil detection test. line-impstart-test—Starts an impulse noise test. line-impread-test—Reads the current result of an impulse noise test. line-impstop-test—Stops an impulse noise test. calib-test—Calibrates the internal test head. tonesnd-test—Sends a test tone down the loop. tonercv-test—Measures the amplitude and frequency of the tone. tdrset-test—Sets TDR parameters. tdr-get—Runs a TDR test. cltm-reset-test—Resets test head electronics. cltm-version—Reports version numbers of hardware and software. cltm-download—Downloads CLT module code. dmm-dcdel-test—Starts DMM dc delta test. dmm-cape-test—Starts DMM equivalent capacitance test. dmm-all-test—Starts DMM ALL test. tx-ctrl-tone-test—Sends a control tone. tx-trace-tone-test—Sends a trace tone. stop-tone-test—Stops sending tones.

Parameter	Setting
test-operation	<p>det-ringer-test—Starts a detect ringer test.</p> <p>det-atur-test—Starts an ATU-R detection test. ADSL LIMs only.</p> <p>btap-test—Starts a bridge tap detection test.</p> <p>voice-det-test—Starts a voice signal detection test.</p> <p>line-fclloc-test—Starts a first load coil detection test.</p> <p>line-shortloc-test—Starts a short-circuit location test.</p> <p>set-responder-test Places CLT module in or out of responder mode.</p> <p>set-bypass-test Toggles splitter bypass.</p> <p>splitter-detect-test—Tests for the presence of a splitter.</p> <p>dmm-acdel-test—DMM ac delta test.</p> <p>dmm-lbal-test—Longitudinal balance test.</p> <p>dmm-soak-test—Soak measurement <i>not supported</i>.</p> <p>send-voice-test—Send voice signal.</p> <p>meas-voice-test—Voice signal detection.</p> <p>meas-dta-test—Analyze subscriber dial tone.</p> <p>detaptor-test—Detaptor test.</p>
dmm-type	<p>Type of DMM test to run:</p> <p>ohm—Resistance test.</p> <p>dcv—dc voltage test.</p> <p>acv—ac voltage test.</p> <p>cap—Capacitance test.</p>
dmm-lead	<p>Leads to use for DMM testing:</p> <p>t-r—Measures between tip and ring.</p> <p>t-s—Measures between tip and sleeve (ground).</p> <p>r-s—Measures between ring and sleeve (ground).</p>
background-noise-filter	<p>Filter to be used for background noise tests:</p> <p>PSD—Measures power spectral density in a 22kHz-to-1.6Mhz range.</p> <p>E—Reports one noise value at 135-ohm impedance for a 1KHz-to-50kHz range. Used for ISDN qualification.</p> <p>F—Reports one value for a 5kHz-to-245kHz range. Used for HDSL qualification.</p> <p>G—Reports one noise value at 100-ohm impedance for 20kHz-to-1.1MHz range. Used for ADSL qualification.</p>

Parameter	Setting
background-noise-termination	Receiver termination for a background noise test: term100—Places a 100-ohm termination on the received signal. term135—Places a 135-ohm termination on the received signal. bridge100—Puts the receiver in high-impedance mode, and calculates the noise signal based on 100-ohm impedance. bridge135—Puts the receiver in high-impedance mode, and calculates the noise signal based on 135-ohm impedance.
loop-resistance-unit	Units of measurement for a loop resistance test: english—Uses English units for test parameters. metric—Uses metric units for test parameters.
loop-resistance-temp	Temperature of the loop: In English units, a value in the range 0 through 100 degrees F In metric units, a value in the range -178 through 93.3 degrees C in tenths (0.1) of a degree
impulse-noise-start-thresh	Threshold value of the smallest noise spike detected, a value within the range 50dBm through 100dBm.
impulse-noise-start-delta	Delta—the number of decibels referred to 1mW (dBm) above the threshold—to measure for noise spike detection, a value within the range 2dBm through 6dBm.
impulse-noise-start-max-count	Maximum number of impulse events to be counted during a single measurement, a value within the range 1 through 9999 counts.
impulse-noise-start-dead-time	Measurement delay after the unit detects the initial impulse, a value within the range 10 through 2550 tenths (0.1) of a millisecond (ms).
impulse-noise-start-timer	Duration of impulse noise measurement, a value within the range 1 through 9999 minutes.
calibration-type	insertion-loss—Calibration type for insertion loss test. background-noise—Calibration type for the background noise test.
tone-send-frequency	Frequency of the sent tone, a value within the range 10kHz through 1600kHz.
tone-send-level	Amplitude of the sent tone, a value within the range -10dBm through 10dBm.
tone-send-period	Period for the tonesnd function Range is 1 to 120 minutes with a default of 60 minutes.
tdr-unit	Units of measurement for TDR testing: english English units are used for the measurement. metric—Metric units are used for the measurement.
tdr-gauge	Gauge of the cable in the loop: In English units, the value is 22, 24 or 26 AWG. In metric units, the value is 4, 5, or 6 tenths of a millimeter.

Parameter	Setting
tdr-vp	Velocity of propagation for the cable under test, a value within the range 40% through 99% of the speed of light.
tdr-avg	Number of times the TDR pulse is sent, a value within the range 1 through 5 pulses. Results are averaged if more than one pulse is used.
tdr-get-type	Mode of TDR test: auto—First fault is automatically detected. manual—You specify the measurement range.
tdr-start-distance	In manual mode, the distance at which to start the TDR measurement: In English units, a value within the range 15 through 20,000 feet. In metric units, a value within the range 5 through 6097 meters.
tdr-measurement-length	In manual mode, the total length of the TDR measurement, starting from tdr-start-distance: In English units, a value within the range 100 through 20,000 feet. The sum of tdr-start-distance and tdr-measurement-length must not exceed 20,000 feet. In metric units, a value within the range 32 through 6097 meters. The sum of tdr-start-distance and tdr-measurement-length must not exceed 6097 meters.
Dmmdcd-Period	Settling time for the dc delta measurement. Values are 0 and 1 to 5 tenths (0.1) second. A zero (0) value sets the default maximum time.
Dmmdcd-Voltage	Test voltage for the dc delta measurement. Range is -230 to 230 V.
Dmmdcd-Impedance	Output impedance for the dc delta measurement. Range is 10 to 1000 Kohm.
Dmncap-period	Settling time for the capacitance measurement. Values are 0 and 1 to 5 tenths (0.1) second. A zero (0) value sets the default maximum time.
Dmmall-Type	Type of DMM ALL test desired. OHM—Resistance test. DCV—DC voltage test. ACV—AC voltage test. CAP—Capacitance test.
Dmmall-Period	Settling time for the DMM ALL measurement. Values are 0 and 1 to 5 tenths (0.1) second. A zero (0) value sets the default maximum time.

Parameter	Setting
Dmmall-Input-Imp	Input impedance for the DMM ALL measurement. Valid values are 100 or 1000 Kohm.
Ctone-Type	Type of DSL service for command tone. ADSL GLITE
Ctone-Tone	Type of command tone. QUIET RESTORE
Ttone-Lead	Leads to use for trace tone. T-R—Tip to ring. T-S—Tip to shield. R-S—Ring to shield.
Ttone-Level	Power level of trace tone. Range is -10dBm to 10dBm.
Ttone-Period	Period for trace tone. Range is 1 to 120 minutes, with a default of 60 minutes.
Btap-Start-Length	Starting location for bridge-tap search. Range is 15 to 20000 feet if TDR units is set to ENGLISH. Range is 5 to 6097 meters if TDR units is set to METRIC.
Btap-Measure-Length	Loop length for bridge tap search. Range is 100 to 20000 feet if TDR units is set to ENGLISH. Range is 32 to 6097 meters if TDR units is set to METRIC.
fc1loc-unit	Units of measurement for first coil location test: english—English units are used for the measurement. metric—Metric units are used for the measurement.
fc1loc-gauge	Gauge of the cable in the loop: In English units, the value is 22, 24 or 26 AWG. In metric units, the value is 4, 5, or 6 tenths of a millimeter.
shortloc-unit	Units of measurement for short-circuit location test. english—English units are used for the measurement. metric—Metric units are used for the measurement.
shortloc-gauge	Gauge of the cable in the loop: In English units, the value is 22AWG, 24AWG or 26AWG. In metric units, the value is 4, 5, or 6 tenths of a millimeter.

Parameter	Setting
shortloc-type	Type of short-circuit test. detect—Detects the short circuit with a DMM test and then measures its location. nodet—Measures the distance to a short circuit without a DMM test.
setresp-mode	Enables or disables responder mode. yes—Enables responder mode. no—Disables responder mode.
setresp-mode-period	Sets the length of time the CLT remains in responder mode. Range is 1 to 999 minutes. This parameter is active only when setresp-mode is set to yes.
dmmacd-period	Amount of time the during which the dmmacd measurement is made. Specify a value from 1 to 5 tenths (.1) seconds. The default value is 0.
dmmacd-voltage	Voltage to use for the dmmacd test. Specify a value from 1Vrms to 24Vrms. The default value is 0.
dmmacd-frequency	Frequency of the dmmacd test voltage. Specify a value from 20 to 2000 Hz. The default value is 0.
dmmalbal-period	Amount the time the dmmalbal measurement is made. Specify a value from 1 to 5 tenths (.1) seconds. The default value is 0.
dmmalbal-voltage	Voltage to use for the dmmalbal test. Specify a value from 1Vrms to 24Vrms. The default value is 0.
dmmalbal-frequency	Frequency of the dmmalbal test voltage. Specify a value from 20Hz to 2000Hz. The default value is 0.
dmmsoak-voltage	<i>Not currently supported.</i>
dmmsoak-configuration	<i>Not currently supported.</i>
dmmsoak-resistance	<i>Not currently supported.</i>
dmmsoak-no-of-samples	<i>Not currently supported.</i>
dmmsoak-interval	<i>Not currently supported.</i>
sendvoice-op-mode	Type of test used for sendvoice test. Specify on of the following values: tone—Tone mode of operation for the sendvoice test. 3-tone—Three-tone mode of operation for the sendvoice test. sweep—Sweep mode of operation for the sendvoice test. dtmf—DTMF mode of operation for the sendvoice test. mf—MF mode of operation for the sendvoice test. digit—Digit mode of operation for the sendvoice test.
sendvoice-frequency	Frequency of operation for sendvoice test in tone mode. Specify a value from 300Hz to 4000Hz. Default value is 0.

Parameter	Setting
sendvoice-deci bal -level	Signal level for tone, 3-tone, and sweep modes of sendvoice test. Specify a value from -30dBm to 10dBm. The default is 0.
sendvoice-time-duration	Time duration for tone and 3-tone modes of sendvoice test. Specify a value from 1 to 120 minutes.
sendvoice-tone-period	Tone period for each tone in the 3-tone and sweep modes of the sendvoice test. Specify a value from 1 to 10 seconds. The default value is 0.
sendvoice-start-freq	Starting frequency for the sweep mode of the sendvoice test. Specify a value from 300Hz to 20000Hz. The default value is 0.
sendvoice-end-freq	Ending frequency for the sweep mode of the sendvoice test. Specify a value from 300Hz to 20000Hz. The default value is 0.
sendvoice-freq-increase	Amount of frequency increase for each successive tone for the sweep mode of the sendvoice test. Specify a value from 10Hz to 1000Hz. The default value is 0.
sendvoice-dtmf-mf-tone	List of digits to send as DTMF or MF digits. Specify an ASCII digit string of up to 20 characters. Default value is null.
sendvoice-digit-string	List of digits to send as individual voice announcements. Specify up to 20 digits from 0 to 9. The default value is 0.
detap-unit	Measurement system for detap test. Specify one of the following values: enl i sh—Specifies English units. metri c—Specifies metric units.
detap-voltage	Voltage to use for the detap test. Specify a value from 0 to 99 volts. The default value is 0.
measvoice-opmode	Specifies the mode of operation for the measvoice test. Select one of the following values: auto—Auto mode of operation for measvoice test dtmf—DTMF mode of operation for measvoice test mf—MF mode of operation for measvoice test tone—Tone mode of operation for measvoice test bgns—Background noise mode of operation for measvoice test sgns—Signal to noise ratio mode of operation for measvoice test
measvoice-det-period	The detection period of the measvoice test in the auto, dtmf and mf modes. Specify a value from 1 to 20 seconds. The default is zero.
measvoice-bgns-mode	Type of filter to use for the background noise test. Specify one of the following values: cmsg—Use a C-message filter. This is the default value. 3kfl at—Use a 3K-flat filter.

Parameter	Setting
measdta-opmode	<p>Test mode for the test subscriber dialtone test. Select one of the following values:</p> <p>term—Break the dialtone by removing the bridge. This is the default.</p> <p>dtmf—Break the dialtone by using a DTMF tone.</p>

Determining test results

Test results are reported in the `clt-result` profile. The `clt-result` parameter values are set to zero or default at the start of each test. The `test-result-status` parameter is set to `not-ready` at the start of each test and is updated to `valid` or `out-of-range` at the end of each test. Use the `list` command to monitor the value of this parameter.

At the end of a test, the results corresponding to the test specified by the `test-operation` parameter in the `clt-command` profile are updated. Use the `list` command to display the parameter values associated with the test.

Following are the `clt-result` parameters, shown with sample values.

```
[in CLT-RESULT]
cltm-slot = slot-16
test-result-time-stamp = 0
test-result-sequence = 0
test-result-status = not-ready
dmm-result = 0
loop-resistance = 0
loop-resistance-length-1 = 0
loop-resistance-length-2 = 0
loop-resistance-length-3 = 0
coil-detection-coil-count = 0
impulse-noise-read-low-threshold = 0
impulse-noise-read-mid-threshold = 0
impulse-noise-read-high-threshold = 0
rcv-tone-frequency = 0
rcv-tone-level = 0
tdr-manual-sample-count = 0
tdr-automatic-fault-distance = 0
hardware-revision = 0
software-revision = 0
psd-frequency-level = [ { 0 0 } { 0 0 } { 0 0 } { 0 0 } { 0 0 } { 0 0 } { 0 } +
tdr-distance-level = [ { 0 0 } { 0 0 } { 0 0 } { 0 0 } { 0 0 } { 0 0 } { 0 } +
dc-delta-resistance-t-r = 0
dc-delta-resistance-t-s = 0
dc-delta-resistance-r-s = 0
dc-delta-voltage-t-s = 0
dc-delta-voltage-r-s = 0
cap-equivalent-t-r = 0
cap-equivalent-t-s = 0
cap-equivalent-r-s = 0
dmm-all-t-r = 0
```

```

dmm-all-t-s = 0
dmm-all-r-s = 0
ringer = 0
atu-r = 0
bridge-tap-number = 0
bridge-tap-length = 0
bridge-tap-table = [ { 0 0 0 } { 0 0 0 } { 0 0 0 } { 0 0 0 } { 0 0 0 } { 0 +
voice-detection = 0
first-coil-location = 0
short-location = 0
splitter-det-result = 0
ac-delta-capacitance-t-r = 0
ac-delta-capacitance-t-s = 0
ac-delta-capacitance-r-s = 0
ac-delta-resistance-t-r = 0
ac-delta-resistance-t-s = 0
ac-delta-resistance-r-s = 0
soak-resistance-t-s = 0
soak-resistance-r-s = 0
dmm-lbal-output-db = 0
detaptor-num-taps = 0
detaptor-tap-length = 0
measvoice-auto-result = 0
measvoice-dtmf-mf-status = 0
measvoice-tone-freq = 0
measvoice-tone-level = 0
measvoice-bgns-result = 0
measvoice-sgns-result = 0
measdta-test-result = none

```

Parameter	Indicates
cltm-slot	Number of the slot where the CLT module or PSM is installed.
test-result-time-stamp	Value of the sysUpTime when the test result was obtained.
test-result-sequence	Sequence of the last test result.
test-result-status	Status of the test: not-ready—Test result not ready. not-valid—Test result not valid. over-range—Test result over range. valid—Test result valid.
dmm-result	Results of a DMM test: Volts ac and volts dc are reported in millivolts (mV). Resistance is reported in ohms. Capacitance is reported in nanofarads (nF).
loop-resistance	Loop resistance is reported in ohms.

Parameter	Indicates
loop-resistance-length-1	<p>If units are set to <code>english</code>, <code>length-1</code> reports the estimated length in hundredths (0.01) of a foot, on the basis of a 22-AWG cable size.</p> <p>If units are set to <code>metric</code>, <code>length-1</code> reports the estimated length in centimeters, on the basis of a 0.644mm cable size.</p>
loop-resistance-length-2	<p>If units are set to <code>english</code>, <code>length-2</code> reports the estimated length in hundredths (0.01) of a foot, on the basis of a 24-AWG cable size.</p> <p>If units are set to <code>metric</code>, <code>length-2</code> reports the estimated length in centimeters, on the basis of a 0.511mm cable size.</p>
loop-resistance-length-3	<p>If units are set to <code>english</code>, <code>length-3</code> reports the estimated length in hundredths (0.01) of a foot, on the basis of a 26-AWG cable size.</p> <p>If units are set to <code>metric</code>, <code>length-3</code> reports the estimated length in centimeters, on the basis of a 0.405mm cable size.</p>
coil-detection-coil-count	Number of load coils detected.
impulse-noise-read-low-threshold	Number of impulse noise events with levels between the threshold value and the <code>threshold-plus-delta</code> value.
impulse-noise-read-mid-threshold	Number of impulse events with levels between the <code>threshold-plus-delta</code> value and the <code>threshold-plus-2delta</code> value.
impulse-noise-read-high-threshold	Number of impulse events with levels exceeding the <code>threshold-plus-2delta</code> value.
rcv-tone-frequency	Receive tone frequency in hertz.
rcv-tone-level	Receive tone level in hundredths (0.01) of a dBm.
tdr-manual-sample-count	Number of detected sample pairs via manual TDR test. If the TDR test is performed in auto mode and no faults are found, <code>tdr-manual-sample-count</code> is set to 0.
tdr-automatic-fault-distance	Distance to the first detected fault, reported in hundredths (0.01) of a foot for English units or centimeters for metric units. This value is generated only for TDR tests in automatic mode.
hardware-revision	Revision level for test head hardware.
software-revision	Revision level for test head software.

Parameter	Indicates
psd-frequency-level	<p><i>For background noise tests in PSD mode.</i> Reports 371 pairs of power spectral density (PSD) test data. The first number in each pair is the test frequency in kilohertz. The second number in each pair is the noise level in dBm per hertz.</p> <p><i>For background noise tests in E, F, or G mode.</i> Reports a single value representing aggregated noise in hundredths (0.01) of a dBm.</p> <p><i>For insertion loss tests.</i> Reports 371 pairs of test data. The first number in each pair is the test frequency in kilohertz. The second number in each pair is the loss in hundredths (0.01) of a decibel.</p> <p><i>For signal-to-noise tests.</i> Reports 371 pairs of test data. The first number in each pair is the test frequency in kilohertz. The second number in each pair is the signal-to-noise ratio in hundredths (0.01) of a decibel.</p>
tdr-distance-level	tdr-sample-count pairs of TDR test data. The first number in each pair is the distance in hundredths (0.01) of a foot for English units, or in centimeters for metric units. The second number in each pair is the level-axis raw data in units.
Dc-delta-resistance-t-r	Tip-to-ring delta resistance in ohms. The value 99999999 indicates that the measurement is over range.
Dc-delta-resistance-t-s	Tip-to-shield delta resistance in ohms. The value 99999999 indicates that the measurement is over range.
Dc-delta-resistance-r-s	Ring-to-shield delta resistance in ohms. The value 99999999 indicates that the measurement is over range.
Dc-delta-potential-t-s	Tip-to-shield voltage in millivolts.
Dc-delta-potential-r-s	Ring-to-shield voltage in millivolts.
Cap-equivalent-t-r	Tip-to-ring equivalent capacitance in picofarads.
Cap-equivalent-t-s	Tip-to-shield equivalent capacitance in picofarads.
Cap-equivalent-r-s	Ring-to-shield equivalent capacitance in picofarads.
Dmml-t-r	Tip-to-ring measurement data. Volts dc and volts ac are in millivolts. Resistance is in ohms. Capacitance is in picofarads.
Dmml-t-s	Tip-to-shield measurement data. Volts dc and volts ac are in millivolts. Resistance is in ohms. Capacitance is in picofarads.

Parameter	Indicates
Dmml-r-s	Ring-to-shield measurement data. Volts dc and volts ac are in millivolts. Resistance is in ohms. Capacitance is in picofarads.
Ringer	Ringer detection. Value is NO or YES.
Atu-r	ATU-R detection. Value is NO or YES. Test is for ADSL LIMs only.
Bridge-tap-number	Number of bridge taps.
Bridge-tap-length	Loop length. This value is reported in feet if TDR units is set to ENGLISH, or in meters if TDR units is set to METRIC.
Bridge-tap-table	Sets of three values. One set of values is reported for each bridge tap detected. The current hardware supports only the following single set of bridge-tap data: Bridge-tap distance in feet or meters. Bridge-tap length in feet or meters. Confidence level in percentage. Valid values are 33 or 50%.
voice-detection	Numeric value indicating the result of the test. 1—A voice signal was not detected. 2—A voice signal was detected. 3—A steady state indicated possible data traffic. 4—An interrupted tone of 60 or 120 impulses per minute (IPM) was detected.
first-coil-location	Distance to the first load coil detected. Distance is reported in centimeters if units are set to metric. Distance is reported in hundredths of feet if units are set to english. A value of 0 indicates no load coil was detected.
short-location	Distance to the short circuit detected. Distance is reported in centimeters if units are set to metric. Distance is reported in hundredths of feet if units are set to english. A value of 0 indicates that no short circuit was detected.
splitter-det-result	Indicates if a splitter has been detected. 1—Splitter not detected. 2—Splitter detected.
ac-delta-capacitance-t-r	Tip-ring ac delta capacitance in picofarads. A value above 2 μ f indicates an overrange.
ac-delta-capacitance-t-s	Tip-shield ac delta capacitance in picofarads. A value above 2 μ f indicates an overrange.
ac-delta-capacitance-r-s	Ring-shield ac delta capacitance in picofarads. A value above 2 μ f indicates an overrange.

Parameter	Indicates
ac-delta-resistance-t-r	Tip-ring ac delta resistance in ohms. A value above 5mohms indicates an overrange.
ac-delta-resistance-t-s	Tip-shield ac delta resistance in ohms. A value above 5mohms indicates an overrange.
ac-delta-resistance-r-s	Ring-shield ac delta resistance in ohms. A value above 5mohms indicates an overrange.
soak-resistance-t-s	<i>Not supported.</i>
soak-resistance-r-s	<i>Not supported.</i>
dmm-lbal-output-db	Longitudinal balance in dB.
detaptor-num-taps	Number of bridge taps detected.
detaptor-tap-length	Bridge tap length in hundredths (.01) feet for english units or in centimeters for metric units.
measvoice-auto-result	Results of measvoice test for auto mode. Possible results are: 1—Voice signal not detected. 2—Voice signal detected. 3—Steady state - possible data traffic. 4—Interrupted tone detected - 60 or 120 IPM.
measvoice-dtmf-mf-status	Results of measvoice test for dtmf-mf mode. Possible results are: 1—No DTMF or MF tone detected. 2—DTMF or MF tone detected.
measvoice-tone-freq	Frequency of detected tone in tone mode. Results are reported in hundredths (.01) Hz.
measvoice-tone-level	Level of detected tone in tone mode. Results are reported in hundredths (.01) dBm.
measvoice-bgns-result	Background noise level reported in hundredths (.01) dBm.
measvoice-sgns-result	Signal to noise ratio reported in hundredths (.01) dBm.
measdta-test-result	Results of subscriber dialtone test. Possible values are: none—No result. draw-break—Draw and break dial tone. draw-no-break—Draw dial tone but no break. slow-break—Slow dialtone draw and break. slow-no-break—Slow dialtone with no break. cannot-draw— Cannot draw dial tone. noisy—Noisy line.

Copper Loop Testing through SNMP

3

Ascend-CLTM-MIB groups	3-1
CLT module access group—cltmAccess	3-1
CLT module command group—cltmCmd.	3-3
CLT module results group—cltmRslt	3-14

You can use SNMP objects to access the copper loop, specify tests, and obtain test results.

Ascend-CLTM-MIB groups

Three MIB groups are used to sequence copper loop testing: the `cltmAccess` group, the `cltmCmd` group, and the `cltmRslt` group. In addition to these three groups, two additional objects are common to all groups. `CltmScaleSystemType` is an integer that defines the measurement units, and `CltmSlotID` is an integer that defines the Stinger slot number.

CLT module access group—cltmAccess

The access group is used specify the copper loop to be tested and the type of connection to be made between the test head and the copper loop. You must specify values for the seven objects defined in Table 3-1 to select the loop and its connection method. If you use a path selector module (PSM) and an external test head for testing, this is the only action needed.

Table 3-1. CLT module access group object definitions (page 1 of 2)

Object name	Variable type	Specifies
<code>cltmAccessSlot</code>	<code>CltmSlotID</code>	Number of the slot where the CLT module or PSM is installed.
<code>cltmAccessTestSlot</code>	<code>CltmSlotID</code>	Slot number of LIM containing the copper loop to be tested.
<code>cltmAccessTestPort</code>	<code>Integer32</code>	Port number of the copper loop to be tested.

Table 3-1. CLT module access group object definitions (page 2 of 2)

Object name	Variable type	Specifies
cltmAccessAccessMode	Integer	<p>Connection configuration of the copper loop. Value (<i>n</i>) specifies either of the following:</p> <p>looking-out (1) Copper loop is connected only to the test head.</p> <p>bridged (2) Copper loop is connected to the test head and the corresponding port of the spare LIM.</p>
cltmAccessAccessTerminal	Integer	<p>Connection point of the copper loop. Value (<i>n</i>) specifies one of the following:</p> <p>internal-tester-terminal (1) Copper loop is connected to the internal test head of the CLT module.</p> <p>external-tester-terminal (2) Copper loop is connected to the external test terminals of the CLT module or PSM.</p> <p>auxiliary-tester-terminal (3) Copper loop is connected to the auxiliary test terminals of the CLT module or PSM</p> <p>external-loop (4) Internal test head of the CLT module is connected to external terminals.</p>
cltmAccessActivateAccess	Integer	<p>Activates or deactivates CLT module access. Value (<i>n</i>) specifies either of the following:</p> <p>no (1) Copper loop is disconnected from the test head or test terminals.</p> <p>yes (2) Copper loop is connected as specified.</p>
cltmAccessAccessResult	Integer	<p>The result of activating the copper loop access. Value (<i>n</i>) specifies one of the following:</p> <p>idle (1) Test head is inactive, and no copper loops are connected.</p> <p>access-activated (2) Test head is active, and a copper loop is connected as specified.</p> <p>resource-busy (3) Resource is busy.</p>
cltmAccessAccessTestLoop	Integer	<p>Copper loop number of the T1 or E1 port. This parameter applies only to copper loops connected to T1 or E1 LIMs and is ignored for all other LIMs.</p> <p>copper-loop-one (1) Connect to transmit copper loop.</p> <p>copper-loop-two (2) Connect to receive copper loop.</p>

CLT module command group—cltmCmd

Use the command group to specify the test to be performed. See Table 3-2.

Table 3-2. CLT module command group object definitions (page 1 of 11)

Object name	Variable type	Specifies
cltmCmdSlot	CltmSlotID	Slot number where the CLT module or PSM is installed.
cltmCmdTestTimeStamp	TimeTicks	Time elapsed after startup (sysUpTime) when the last test specified by cltmCmdTestOperation was run. The time stamp is computed on the basis of the startup time of the module. A write operation to any object in CltmCmdEntry resets this value to 0.
cltmCmdTestSequence	Counter32	CLT module test sequence number.
cltmCmdTestOperation	Integer	Type of test desired. Value (<i>n</i>) specifies one of the following: none (1) No test is activated. Setting this value to none stops the test procedure. dmm (2) Digital multimeter (DMM) tests. line-insertion-loss (3) Insertion loss test. line-background-noise (4) Background noise test. line-signal-to-noise (5) Signal-to-noise ratio test. line-loop-resistance (6) Loop resistance test. line-coil-detection (7) Coil detection test. line-impulse-noise-start (8) Impulse noise test start. line-impulse-noise-stop (9) Impulse noise test stop. line-impulse-noise-read (10) Impulse noise test reading. calibration (11) Calibrate. tone-send (12) Send tone. tone-recv (13) Receive tone. tdr-set (14) TDR test start.

Table 3-2. CLT module command group object definitions (page 2 of 11)

Object name	Variable type	Specifies
cltmCmdTestOperation (cont.)	Integer	<p>tdr-get (15) TDR test result reading.</p> <p>cltm-reset (16) Reset CLT module.</p> <p>version (17) Report version number of CLT module.</p> <p>download (18) Download tester operation code.</p> <p>dmm-dc-delta (19) Digital multimeter (DMM) dc delta measurement.</p> <p>dmm-capacitance-equivalent (20) DMM capacitance equivalent measurement.</p> <p>dmm-all (21) DMM all leads pair test.</p> <p>send-control-tone (22) Send control tone function.</p> <p>stop-tone (24) Stop tone function.</p> <p>ringer-detect (25) Detect ringer function.</p> <p>cpe-detect (26) Detect ATU-R function. ADSL LIMs only.</p> <p>bridge-tap-detect (27) Bridge-tap measurement.</p> <p>voice-detection (28) Voice signal detection test.</p> <p>line-first-coil-location (29) Measures the distance to first load coil in the copper loop.</p> <p>line-short-location (30) Measures the distance to short in loop.</p> <p>set-responder (31) Puts the CLT module in responder mode.</p> <p>set-bypass (32) Toggles splitter bypass.</p> <p>splitter-detect (33) Detects the presence or absence of a splitter.</p> <p>dmm-ac-delta (34) DMM ac delta measurement.</p> <p>dmm-long-balance (35) DMM longitudinal balance measurement.</p> <p>dmm-soak (36) <i>Not supported.</i></p>

Table 3-2. CLT module command group object definitions (page 3 of 11)

Object name	Variable type	Specifies
cltmCmdTestOperation (cont.)		send-voice (37) Send voice signal test. meas-voice (38) Measure voice and tone signals on lines. meas-dta (39) Draw and break dialtone test. detaptr (40) Bridge tap length measurement.
cltmCmdDmmType	Integer	Type of DMM test. Value (<i>n</i>) specifies one of the following: resistance (1) Resistance test. dcVoltage (2) dc voltage test. acVoltage (3) ac voltage test. capacitance (4) Capacitance test.
cltmCmdDmmLeads	Integer	Leads to use for DMM testing. Value (<i>n</i>) specifies one of the following: tip-ring (1) Measure between tip and ring. tip-sleeve (2) Measure between tip and shield (ground). ring-sleeve (3) Measure between ring and shield (ground).
cltmCmdBackgroundNoiseFilter	Integer	Filter to be used for background noise tests. Value (<i>n</i>) specifies one of the following: psd (1) Power spectral density (PSD) measurement 22kHz to 1.6MHz. e (2) Reports one noise value at 135-ohm impedance for a 1kHz-to-50kHz range. Used for ISDN qualification. f (3) Reports one value for 5kHz-to-245kHz range. Used for HDSL qualification. g (4) Reports one noise value at 100-ohm impedance for a 20kHz-to-1.1Mhz range. Used for ADSL qualification.

Table 3-2. CLT module command group object definitions (page 4 of 11)

Object name	Variable type	Specifies
cltCmdBackgroundNoiseTerm	Integer	Sets the receiver termination for the background noise test. Value (<i>n</i>) specifies one of the following: term100 (1) Places a 100-ohm termination on the received signal. term135 (2) Places a 135-ohm termination on the received signal. bridge100 (3) Puts receiver in high impedance mode, and calculates a noise signal based on 100-ohm impedance. bridge 135 (4) Puts receiver in high impedance mode, and calculates a noise signal based on 135-ohm impedance.
cltCmdLoopResistanceUnit	CltmScaleSystemType	Units of measurement for loop resistance test: CltmScaleSystemType (1) Metric. CltmScaleSystemType (2) English.
cltCmdLoopResistanceTemp	Integer 32	Line temperature for loop resistance test: In English units, a value in the range 0 through 100 degrees F In metric units, a value in the range -178 through 93.3 degrees C in tenths (0.1) of a degree [
cltCmdImpulseNoiseStartThresh	Integer	Threshold for the smallest noise spike detected, a value in the range 50dBm through 100dBm.
cltCmdImpulseNoiseStartDelta	Integer	Delta—the number of decibels referred to 1mW (dBm) above the threshold—for noise spike detection, a value in the range 2dBm through 6dBm.
cltCmdImpulseNoiseStartMaxCount	Integer	Maximum number of impulse events to be counted during a single measurement, a value in the range 1 through 9999 counts.
cltCmdImpulseNoiseStartDeadTime	Integer	Measurement delay after the unit detects the initial impulse, a value in the range 10 through 2550 tenths (0.1) of a millisecond (ms).
cltCmdImpulseNoiseStartTimer	Integer	Duration of impulse noise measurement, a value in the range 1 through 9999 minutes.

Table 3-2. CLT module command group object definitions (page 5 of 11)

Object name	Variable type	Specifies
cltCmdCalibrationType	Integer	insertion-loss Calibration type for insertion loss test. background-noise Calibration type for the background noise test.
cltCmdToneSendFreq	Integer	Frequency of the sent tone, a value in the range 10kHz through 1600kHz.
cltCmdToneSendLevel	Integer	Amplitude of the sent tone, a value in the range -10dBm through 10dBm.
cltCmdTdrUnit	CltmScaleSystemType	Units of measurement for TDR testing. Value (n) specifies one of the following: CltmScaleSystemType (2) English. CltmScaleSystemType (1) metric.
cltCmdTdrGauge	Integer 32	Gauge of the cable in the loop: In English units, the value is 22 AWG, 24 AWG. or 26 AWG. In metric units, the value is 4, 5, or 6 tenths of millimeter.
cltCmdTdrVp	Integer	Velocity of propagation for the cable under test, a value in the range 40% through 99% of the speed of light.
cltCmdTdrAvg	Integer	Number of times the TDR pulse is sent, a value in the range 1 through 5 pulses. Results are averaged if more than one pulse is used.
cltCmdTdrGetType	Integer	Mode of TDR test. Value (n) specifies either of the following: automatic (1) First fault is automatically detected. manual (2) You specify the measurement range. If this object is set to automatic, cltCmdTdrStartLen and cltCmdTdrMeasureLen do not have to be set.

Table 3-2. CLT module command group object definitions (page 6 of 11)

Object name	Variable type	Specifies
cltCmdTdrStartLen	Integer 32	Distance at which to start the TDR measurement in manual mode: In English units, a value within the range 15 feet through 20,000 feet. In metric units, a value within the range 5 meters through 6097 meters.
cltCmdTdrMeasureLen	Integer 32	Total length of the TDR measurement in manual mode starting from cltCmdTdrStartLen. In English units, a value within the range is 100 feet through 20,000 feet. The sum of cltCmdTdrStartLen and cltCmdTdrMeasureLen must not exceed 20,000 feet. In metric units, a value within the range 32 meters through 6097 meters. The sum of cltCmdTdrStartLen and cltCmdTdrMeasureLen must not exceed 6097 meters.
cltmCmdDmmDcDeltaPeriod	Integer32	Settling time for the measurement. Values are 0 and 1 to 5 tenths (0.1) second. A zero (0) value sets the default maximum time.
cltmCmdDmmDcDeltaVoltage	Integer32	Test voltage. Range is -230 to 230 volts.
cltmCmdDmmDcDeltaImpedance	Integer32	Output impedance for the test. Range is 10 to 1000 Kohm.
cltmCmdDmmCapacitancePeriod	Integer32	Settling time for the capacitance measurement. Values are 0 and 1 to 5 tenths (0.1) second. A zero (0) value sets the default maximum time.
cltmCmdDmmAllType	CltmDmmType	Type of DMM test desired. OHM—Resistance test. DCV—DC voltage test. ACV—AC voltage test. CAP—Capacitance test.

Table 3-2. CLT module command group object definitions (page 7 of 11)

Object name	Variable type	Specifies
cltmCmdDmmAllPeriod	Integer32	Settling time for the measurement. Values are 0 and 1 to 5 tenths (0.1) second. A zero (0) value sets the default maximum time.
cltmCmdDmmAllInputImp	Integer32	Input impedance for the test. Valid values are 100 or 1000 Kohm.
cltmCmdControlToneDslType	INTEGER	Type of DSL service. ADSL (1) GLITE (2)
cltmCmdControlToneDslTone	INTEGER	Type of tone. QUIET RESTORE
cltmCmdTraceToneLead	CltmDmmLeadType	Leads to use for trace tone. T-R—Tip to ring. T-S—Tip to shield. R-S—Ring to shield.
cltmCmdTraceToneLevel	Integer32	Power level of trace tone. Range is -10dBm to 10dBm.
cltmCmdTraceTonePeriod	Integer32	Range is 1 to 120 minutes, with a default of 60 minutes.
cltmCmdBridgeTapStart	Integer32	Starting location for bridge-tap search. Range is 15 to 20000 feet if TDR units is set to ENGLISH. Range is 5 to 6097 meters if TDR units is set to METRIC.
cltmCmdBridgeTapMeasureLen	Integer32	Loop length for bridge-tap search. Range is 100 to 20000 feet if TDR units is set to ENGLISH. Range is 32 to 6097 meters if TDR units is set to METRIC.

Table 3-2. CLT module command group object definitions (page 8 of 11)

Object name	Variable type	Specifies
cltmCmdFirstCoilLocUnit	Integer	Units of measurement for first coil location test. metric (1) Metric units are used for the measurement. english (2) English units are used for the measurement.
cltmCmdFirstCoilLocGauge	Integer32	Gauge of the cable in the loop: In English units, the value is 22, 24 or 26 AWG. In metric units, the value is 4, 5, or 6 tenths of a millimeter.
cltmCmdShortLocUnit	Integer	Units of measurement for short-circuit location test. english (1) English units are used for the measurement. metric (2) Metric units are used for the measurement.
cltmCmdShortLocGauge	Integer32	Gauge of the cable in the copper loop: In metric units, the value is 4, 5, or 6 tenths of a millimeter. In English units, the value is 22, 24 or 26 AWG.
cltmCmdShortLocType	Integer	Type of short-circuit test. detect (1) Detects the short circuit with a DMM test and then measures its location. nodet (2) Measures the distance to a short circuit without a DMM test.
cltmCmdSetRespOpMode	Integer	Enables or disables responder mode. yes (1) Enables responder mode. no (0) Disables responder mode.
cltmCmdSetRespPeriod	Integer32	Sets the length of time the CLT module remains in responder mode. Range is 1 to 999 minutes. This parameter is active only when cltmCmdSetRespOpMode is set to yes.

Table 3-2. CLT module command group object definitions (page 9 of 11)

Object name	Variable type	Specifies
cltmCmdDmmAcDeltaPeriod	Integer32	Amount of time during which the dmmacd measurement is made. Specify a value from 1 to 5 tenths (.1) seconds. The default value is 0.
cltmCmdDmmAcDeltaVoltage	Integer32	Voltage to use for the dmmacd test. Specify a value from 1Vrms to 24Vrms. The default value is 0.
cltmCmdDmmAcDeltaFrequency	Integer32	Frequency of the dmmacd test voltage. Specify a value from 20Hz to 2000Hz. The default value is 0.
cltmCmdDmmLongBalPeriod	Integer32	Amount the time the dmm bal measurement is made. Specify a value from 1 to 5 tenths (.1) seconds. The default value is 0.
cltmCmdDmmLongBalVoltage	Integer32	Voltage to use for the dmm bal test. Specify a value from 1Vrms to 24Vrms. The default value is 0.
cltmCmdDmmLongBalFrequency	Integer32	Frequency of the dmm bal test voltage. Specify a value from 20Hz to 2000Hz. The default value is 0.
cltmCmdSendVoiceOpMode	Integer	Type of test used for sendvoice test. Specify one of the following numerical values: tone (1)—Tone mode of operation for the sendvoice test. 3-tone (2)—Three-tone mode of operation for the sendvoice test. sweep (3)—Sweep mode of operation for the sendvoice test. dtmf (4)—DTMF mode of operation for the sendvoice test. mf (5)—MF mode of operation for the sendvoice test. digit (6)—Digit mode of operation for the sendvoice test.
cltmCmdSendVoiceFreq	Integer32	Frequency of operation for sendvoice test in tone mode. Specify a value from 300Hz to 4000Hz. Default value is 0.

Table 3-2. CLT module command group object definitions (page 10 of 11)

Object name	Variable type	Specifies
cltmCmdSendVoiceLevel	Integer32	Signal level for tone, 3-tone, and sweep modes of sendvoice test. Specify a value from -30dBm to 10dBm. The default is 0.
cltmCmdSendVoiceTime	Integer32	Time duration for tone and 3-tone modes of sendvoice test. Specify a value from 1 to 120 minutes.
cltmCmdSendVoiceTonePeriod	Integer32	Tone period for each tone in the 3-tone and sweep modes of the sendvoice test. Specify a value from 1 to 10 seconds. The default value is 0.
cltmCmdSendVoiceStartFreq	Integer32	Starting frequency for the sweep mode of the sendvoice test. Specify a value from 300Hz to 20000Hz. The default value is 0.
cltmCmdSendVoiceEndFreq	Integer32	Ending frequency for the sweep mode of the sendvoice test. Specify a value from 300Hz to 20000Hz. The default value is 0.
cltmCmdSendVoiceFreqIncr	Integer32	Amount of frequency increase for each successive tone for the sweep mode of the sendvoice test. Specify a value from 10Hz to 1000Hz. The default value is 0.
cltmCmdSendVoiceDtmfMfTone	SnpAdminString	List of digits to send as DTMF or MF digits. Specify an ASCII digit string of up to 20 characters. Default value is null.
cltmCmdSendVoiceDigitString	Integer32	List of digits to send as individual voice announcements. Specify up to 20 digits from 0 to 9. The default value is 0.
cltmCmdDetapUnit	Integer	Measurement system for detap test. Specify one of the following numeric values: english (1)—Specifies English units. metric (2)—Specifies metric units.
cltmCmdDetapVolt	Integer32	Voltage to use for the detap test. Specify a value from 0 to 99 volts. The default value is 0.

Table 3-2. CLT module command group object definitions (page 11 of 11)

Object name	Variable type	Specifies
cltmCmdVoiceSigOpMode	Integer	Specifies the mode of operation for the measvoice test. Value (<i>n</i>) specifies one of the following: auto (1)—Auto mode of operation for measvoice test dtmf (2)—DTMF mode of operation for measvoice test mf (3)—MF mode of operation for measvoice test tone (4)—Tone mode of operation for measvoice test bgns (5)—Background noise mode of operation for measvoice test sgns (6)—Signal to noise ratio mode of operation for measvoice test
cltmCmdVoiceSigDetPeriod	Integer32	The detection period of the measvoice test in the auto, dtmf and mf modes. Specify a value from 1 to 20 seconds. The default is zero.
cltmCmdVoiceSigBgnsMode	Integer	Type of filter to use for the background noise test. Value (<i>n</i>) specifies one of the following cmsg (1)—Use a C-message filter. This is the default value. 3kflat (2)—Use a 3K-flat filter.
cltmCmdMeasDtaOpMode	Integer	Test mode for the test subscriber dialtone test. Value (<i>n</i>) specifies one of the following: term (1)—Break the dialtone by removing the bridge. This is the default. dtmf (2)—Break the dialtone by using a DTMF tone.

CLT module results group—cltmRslt

The results group is used to obtain the data associated with a test specified through the command group. Many of the objects in the group return a single value. Table 3-3 defines these single-value objects.

Table 3-3. CLT module results group single-value object definitions (page 1 of 4)

Object name	Variable type	Specifies
cltmRsltSlot	CltmSlotID	Slot number where the CLT module or PSM is installed.
cltmRsltTestResultTimeStamp	TimeTicks	Time elapsed after startup (sysUpTime) when the last result was obtained. The time stamp is computed on the basis of the startup time of the module.
cltmRsltTestResultsSequence	Counter32	Sequence number of the current test result. This value matches the sequence number of the CLT module test that caused this result.
cltmRsltTestResultStatus	Integer	Value (<i>n</i>) specifies one of the following: not-ready (1) Result is not ready. not-valid (2) Result is not valid. over-range (3) Result is out of range. valid (4) Result is valid.
cltmRsltDmmResult	Integer32	Results of a DMM test: Volts ac and volts dc are reported in millivolts (mV). Resistance is reported in ohms. Capacitance is reported in nanofarads (nF).
cltmRsltLoopResistance	Integer32	Loop resistance is reported in ohms.
cltmRsltLoopResistanceLenAwg22	Integer32	If units are set to English, the value of this object is the estimated length in hundredths (0.01) of a foot, based on a 22-AWG cable size. If units are set to metric, the value is the estimated length in centimeters, based on a 0.644mm cable size.

Table 3-3. CLT module results group single-value object definitions (page 2 of 4)

Object name	Variable type	Specifies
cltmRsltLoopResistanceLenAwg24	Integer32	If units are set to English, the value of this object is the estimated length in hundredths (0.01) of a foot, based on a 24-AWG cable. If units are set to metric, this value is the estimated length in centimeters, based on a 0.511mm cable size.
cltmRsltLoopResistanceLenAwg26	Integer32	If units are set to English, the value of this object is the estimated length in hundredths (0.01) of a foot, based on a 26-AWG cable size. If units are set to metric, this value is the estimated length in centimeters, based on a 0.405mm cable size.
cltmRsltCoilDetectionNumCoil	Integer32	Number of load coils detected.
cltRsltImpulseNoiseReadLowThresh	Integer32	Number of impulse events with levels between threshold and threshold-plus-delta.
cltRsltImpulseNoiseReadMidThresh	Integer32	Number of impulse events with levels between threshold-plus-delta and threshold-plus-2delta.
cltRsltImpulseNoiseReadHighThresh	Integer32	Number of impulse events with levels exceeding threshold-plus-2delta.
cltRsltRcvToneFreq	Integer32	Receive tone frequency in hertz.
cltRsltRcvToneLev	Integer32	Receive tone level in hundredths (0.01) of a dBm.
cltRsltGetSampleCount	Integer32	Number of distance or level data points returned for a TDR test. If the TDR test is performed in auto mode and no faults are found, this value is set to 0.
cltRsltGetTdrAutomaticFaultDist	Integer32	Distance to first detected fault, reported in hundredths (0.01) of a foot for English units, or centimeters for metric units. This value is generated only for TDR tests in automatic mode.
cltRsltHwRevision	Integer32	Revision level for test head hardware.
cltRsltSwRevision	Integer32	Revision level for test head software.

Table 3-3. CLT module results group single-value object definitions (page 3 of 4)

Object name	Variable type	Specifies
cltmRsltDmmDcDeltaResistanceTR	Integer32	Tip-to-ring delta resistance in ohms. The value 99999999 indicates that the measurement is over range.
vvcltmRsltDmmDcDeltaResistanceTS	Integer32	Tip-to-shield delta resistance in ohms. The value 99999999 indicates that the measurement is over range.
cltmRsltDmmDcDeltaResistanceRS	Integer32	Ring-to-shield delta resistance in ohms. The value 99999999 indicates that the measurement is over range.
cltmRsltDmmDcDeltaVoltageTS	Integer32	Tip-to-shield voltage in millivolts.
cltmRsltDmmDcDeltaVoltageRS	Integer32	Ring-to-shield voltage in millivolts.
cltmRsltDmmCapacitanceTR	Integer32	Tip-to-ring equivalent capacitance in picofarads.
cltmRsltDmmCapacitanceTS	Integer32	Tip-to-shield equivalent capacitance in picofarads.
cltmRsltDmmCapacitanceRS	Integer32	Ring-to-shield equivalent capacitance in picofarads.
cltmRsltDmmallTR	Integer32	Tip-to-ring measurement data. Volts dc and volts ac are in millivolts. Resistance is in ohms. Capacitance is in picofarads.
cltmRsltDmmallTS	Integer32	Tip-to-shield measurement data. Volts dc and volts ac are in millivolts. Resistance is in ohms. Capacitance is in picofarads.
cltmRsltDmmallRS	Integer32	Ring-to-shield measurement data. Volts dc and volts ac are in millivolts. Resistance is in ohms. Capacitance is in picofarads.
cltmRsltRingerDetect	INTEGER	ringer-not-detected (1)—Ringer not detected. ringer-detected(2)—Ringer detected.
cltmRsltCpeDetect	INTEGER	cpe-not-detected (1)—CPE not detected. cpe-detected(2)—CPE detected.
cltmRsltBridgeTapNumber	Integer32	Number of bridge taps.

Table 3-3. CLT module results group single-value object definitions (page 4 of 4)

Object name	Variable type	Specifies
cltmRsltBridgeTapLoopLen	Integer32	Loop length. This value is reported in feet if TDR units is set to ENGLISH, or in meters if TDR units is set to METRIC.
cltmRsltVoiceDetection	INTEGER	Numeric value indicating the result of the test. 1—A voice signal was not detected. 2—A voice signal was detected. 3—A steady state indicated possible data traffic. 4—An interrupted tone of 60 or 120 impulses per minute (IPM) was detected.
cltmRsltFirstCoilLocation	Integer32	Distance to the first load coil detected. Distance is reported in centimeters if units are set to metric. Distance is reported in hundredths of feet if units are set to english. A value of 0 indicates that no load coil was detected.
cltmRsltShortLocation	Integer32	Distance to the short circuit detected. Distance is reported in centimeters if units are set to metric. Distance is reported in hundredths of feet if units are set to english. A value of 0 indicates that no short circuit was detected.

Results from a TDR test are returned as multiple values in the cltmRsltDistLevTable. Results from background noise, insertion loss, and signal-to-noise tests are returned in a shared table cltmRsltFreqDbTable. Results from bridge-tap tests are returned in the cltmRsltBridgeTapTable. Table 3-4 defines these objects. cltmRsltDmmAcDeltaResistanceRSccltmRsltMeasVoiceAutoMode

Table 3-4. CLT module results group, table type objects (page 1 of 4)

Object name	Variable type	Specifies
cltmRsltDistLevSlot	CltnSlotID	Number of the slot containing the CLT module performing a TDR test.
cltmRsltDistLevIndex	Integer32	Index to the result array of TDR distance and level data. The result array contains cltRsltGetTdrNum number of data points.

Table 3-4. CLT module results group, table type objects (page 2 of 4)

Object name	Variable type	Specifies
cltmRsltDistLevDistance	Integer32	Distance in hundredths (0.01) of a foot for English units, or centimeters for metric units.
cltmRsltDistLevLevel	Integer32	Level-axis raw data in units.
cltmRsltFreqDbSlot	CltnSlotID	Number of the slot containing the CLT module performing a background noise, insertion loss, or signal-to-noise test.
cltmRsltFreqDbIndex	Integer32	Index to the result array of a test: For a background noise test in power spectral density (PSD) mode, 367 sets of data results. For E, F, or G filter tests, one value is reported. For insertion loss or signal-to-noise tests, 367 sets of data results.
cltmRsltFreqDbFreq	Integer32	For a background noise test in PSD mode, the test frequency in kilohertz. For background noise test, the E, F, or G frequency value is 0. For insertion loss and signal-to-noise tests, the test frequency in kilohertz.
cltmRsltFreqDbDbLevel	Integer32	For a background noise test in PSD mode, the test result in hundredths (0.01) of a dBm per hertz. For a background noise test in E, F, or G mode, a single test value in hundredths (0.01) of a dBm. For insertion loss tests, the test result in hundredths (0.01) of a decibel loss. For a signal-to-noise test, the signal-to-noise ratio in hundredths (0.01) of a decibel.
cltmRsltBridgeTapSlot	CltnSlotID	Slot number of the CLT module performing the bridge-tap test.
cltmRsltBridgeTapIndex	Integer32	Index to the result array holding the bridge-tap data.
cltmRsltBridgeTapDistance	Integer32	Bridge-tap distance, in feet if TDR units is set to ENGLISH, or in meters if TDR units is set to METRIC.
cltmRsltBridgeTapLength	Integer32	Bridge tap length. This value is reported in feet if TDR units is set to ENGLISH, or in meters if TDR units is set to METRIC.

Table 3-4. CLT module results group, table type objects (page 3 of 4)

Object name	Variable type	Specifies
cltmRsltBridgeTapConfidence	Integer32	Confidence level in percentage. Valid values are 33 or 50%.
cltmRsltSplitterRslt	Integer32	Indicates if a splitter has been detected. 1—Splitter not detected. 2—Splitter detected.
cltmRsltDmmAcDeltaCapacitanceTR	Integer32	Tip-ring ac delta capacitance in picofarads. A value above 2µf indicates an overrange.
cltmRsltDmmAcDeltaCapacitanceTS	Integer32	Tip-shield ac delta capacitance in picofarads. A value above 2µf indicates an overrange.
cltmRsltDmmAcDeltaCapacitanceRS	Integer32	Ring-shield ac delta capacitance in picofarads. A value above 2µf indicates an overrange.
cltmRsltDmmAcDeltaResistanceTR	Integer32	Tip-ring ac delta resistance in ohms. A value above 5mohms indicates an overrange.
cltmRsltDmmAcDeltaResistanceTS	Integer32	Tip-shield ac delta resistance in ohms. A value above 5mohms indicates an overrange.
cltmRsltDmmAcDeltaResistanceRS	Integer32	Ring-shield ac delta resistance in ohms. A value above 5mohms indicates an overrange.
cltmRsltDmmLbalOutputDb	Integer32	Longitudinal balance in dB.
cltmRsltDetapNumTaps	Integer32	Number of bridge taps detected.
cltmRsltDetapTapLength	Integer32	Bridge tap length in hundredths (.01) feet for english units or in centimeters for metric units.
cltmRsltMeasVoiceAutoMode	Integer	Results of measvoice test for auto mode. Possible results are: 1—Voice signal not detected. 2—Voice signal detected. 3—Steady state - possible data traffic. 4—Interrupted tone detected - 60 or 120 IPM.
cltmRsltDtmfMfStatus	Integer32	Results of measvoice test for dtmf-mf mode. Possible results are: 1—No DTMF or MF tone detected. 2—DTMF or MF tone detected.

Table 3-4. CLT module results group, table type objects (page 4 of 4)

Object name	Variable type	Specifies
cltmRsltMeasVoiceToneFreq	Integer32	Frequency of detected tone in tone mode. Results are reported in hundredths (.01) Hz.
cltmRsltMeasVoiceToneLevel	Integer32	Level of detected tone in tone mode. Results are reported in hundredths (.01) dBm.
cltmRsltMeasVoiceBgnsRslt	Integer32	Background noise level reported in hundredths (.01) dBm.
cltmRsltMeasVoiceSgnsRslt	Integer32	Signal to noise ratio reported in hundredths (.01) dBm
cltmRsltMeasDtaTestRslt	Integer	Results of subscriber dialtone test. Possible values are: 1—Draw and break dial tone. 2—Draw dial tone but no break. 3—Slow dialtone draw and break. 4—Slow dialtone with no break. 5— Cannot draw dial tone. 6—Noisy line.

CLT Module Specifications



Physical specifications	A-1
Connector pinouts and specifications.	A-2

Physical specifications

Table A-1 shows the CLT module physical specifications. Figure A-1 shows the front panel of the module.

Table A-1. CLT module physical specifications

Characteristic	Specification
Physical dimensions	Height: 15 inches (38.1cm) Width: 1.06 inches (2.69cm) Depth: FS version: 5 inches (12.7cm) LS version: 9 inches (22.8cm) Weight: FS version: 2.0 pounds (0.90kg) LS version: 3.2 pounds (1.45kg)
Power requirements	9.6W
Temperature range	32° to 131°F (0° to 55° C)

Figure A-1. CLTE module front panels. Left: Stinger FS version. Right: Stinger LS/RT version

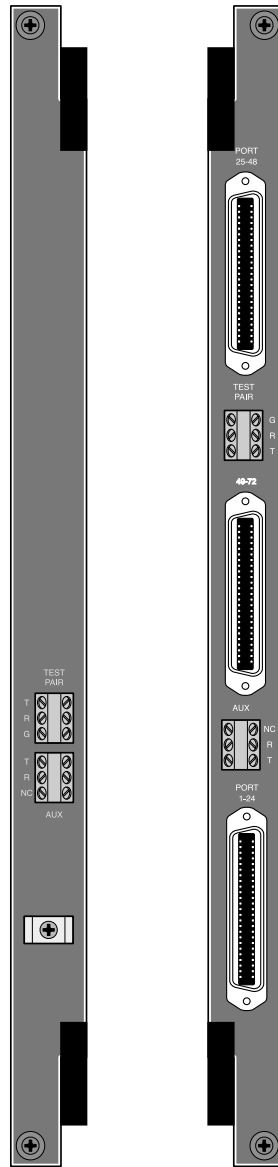

Connector pinouts and specifications

Following are the pinouts and specifications for the SERIAL connector, TEST PAIR connector, and AUX connector on the CLTE module. The version for the Stinger LS also has two PORT connectors.

SERIAL connector

The serial port uses a standard DE-9F female connector that conforms to the EIA RS-232 standard for serial interfaces. Table A-2 shows the pinout for the SERIAL connector.

The serial port parameters are 9600 baud, 8 bits, and no parity.

Table A-2. Serial port (TL1 interface) pinout

DE-9F pin number	RS-232 signal name	Function	I/O
2	RD	Serial Receive Data	O
3	SD	Serial Transmit Data	I
5	GND	Signal Ground	

TEST PAIR connector

The TEST PAIR connector provides access to the copper loop when the `access-terminal` terminal is set to `external`. The connector is a screw compression, three-position terminal block. Table A-3 and Table A-4 show the pinouts for the Stinger FS and Stinger LS versions.

Table A-3. TEST PAIR connector for Stinger FS version

Pin number	Name	Function
1	T	Tip connection of copper loop.
2	R	Ring connection of copper loop.
3	G	Shield connection of copper loop.

Table A-4. TEST PAIR connector for Stinger LS version

Pin number	Name	Function
1	G	Shield connection of copper loop.
2	R	Ring connection of copper loop.
3	T	Tip connection of copper loop.

AUX connector

The AUX connector provides access to the copper loop when the `access-terminal` parameter is set to `auxiliary`. The connector is a screw compression, three-position

terminal block. Table A-5 and Table A-6 show the pinouts for the Stinger FS and Stinger LS versions.

Table A-5. AUX connector for Stinger FS version

Pin number	Name	Function
1	T	Tip connection of copper loop.
2	R	Ring connection of copper loop.
3	NC	Not used.

Table A-6. AUX connector for Stinger LS version

Pin number	Name	Function
1	NC	Not used.
2	R	Ring connection of copper loop.
3	T	Tip connection of copper loop.

Port connector

The PORT connectors are used to connect incoming DSL lines to the LIM to the right of the CLT module. These connectors are present on only the LS and RT version of the CLTE module. A USOC RJ-21X 50-pin telephone company connector is used for each PORT connection. Table A-7, Table A-8 and Table A-9 show these pinouts.

Table A-7. Cable pinouts for PORT 1-24—Stinger LS/RT only (page 1 of 2)

Pin	Signal	Color code	Pin	Signal	Color code
1	1R (line 1 ring)	Blue/white	26	1T (line 1 tip)	White/blue
2	2R	Orange/white	27	2T	White/Orange
3	3R	Green/white	28	3T	White/green
4	4R	Brown/white	29	4T	White/brown
5	5R	Slate/white	30	5T	White/slate
6	6R	Blue/red	31	6T	Red/blue
7	7R	Orange/red	32	7T	Red/orange

Table A-7. Cable pinouts for PORT 1-24—Stinger LS/RT only (page 2 of 2)

Pin	Signal	Color code	Pin	Signal	Color code
8	8R	Green/red	33	8T	Red/green
9	9R	Brown/red	34	9T	Red/brown
10	10R	Slate/rejd	35	10T	Red/slate
11	11R	Blue/black	36	11T	Black/blue
12	12R	Orange/black	37	12T	Black/orange
13	13R	Green/black	38	13T	Black/green
14	14R	Brown/black	39	14T	Black/brown
15	15R	Slate/black	40	15T	Black/slate
16	16R	Blue/yellow	41	16T	Yellow/blue
17	17R	Orange/yellow	42	17T	Yellow/orange
18	18R	Green/yellow	43	18T	Yellow/green
19	19R	Brown/yellow	44	19T	Yellow/brown
20	20R	Slate/yellow	45	20T	Yellow/slate
21	21R	Blue/violet	46	21T	Violet/blue
22	22R	Orange/violet	47	22T	Violet/orange
23	23R	Green/violet	48	23T	Violet/green
24	24R	Brown/violet	49	24T	Violet/brown
25	Not used	N/A	50	Not used	N/A

Table A-8. Cable pinouts for PORT 25-48—Stinger LS/RT only (page 1 of 2)

Pin	Signal	Color code	Pin	Signal	Color code
1	25R (channel 1 ring)	Blue/white	26	25T (channel 1 tip)	White/blue
2	26R	Orange/white	27	26T	White/Orange
3	27R	Green/white	28	27T	White/green
4	28R	Brown/white	29	28T	White/brown

Table A-8. Cable pinouts for PORT 25-48—Stinger LS/RT only (page 2 of 2)

Pin	Signal	Color code	Pin	Signal	Color code
5	29R	Slate/white	30	29T	White/slate
6	30R	Blue/red	31	30T	Red/blue
7	31R	Orange/red	32	31T	Red/orange
8	32R	Green/red	33	32T	Red/green
9	33R	Brown/red	34	33T	Red/brown
10	34R	Slate/red	35	34T	Red/slate
11	35R	Blue/black	36	35T	Black/blue
12	36R	Orange/black	37	36T	Black/orange
13	37R	Green/black	38	37T	Black/green
14	38R	Brown/black	39	38T	Black/brown
15	39R	Slate/black	40	39T	Black/slate
16	40R	Blue/yellow	41	40T	Yellow/blue
17	41R	Orange/yellow	42	41T	Yellow/orange
18	42R	Green/yellow	43	42T	Yellow/green
19	43R	Brown/yellow	44	43T	Yellow/brown
20	33R	Slate/yellow	45	33T	Yellow/slate
21	45R	Blue/violet	46	45T	Violet/blue
22	46R	Orange/violet	47	46T	Violet/orange
23	47R	Green/violet	48	47T	Violet/green
24	48R	Brown/violet	49	48T	Violet/brown
25	Not used	N/A	50	Not used	N/A

Table A-9. Cable pinouts for PORT 49-72 Stinger LS/RT only (page 1 of 2)

Pin	Signal	Color code	Pin	Signal	Color code
1	1R (line 1 ring)	Blue/white	26	1T (line 1 tip)	White/blue

Table A-9. Cable pinouts for PORT 49-72 Stinger LS/RT only (page 2 of 2)

Pin	Signal	Color code	Pin	Signal	Color code
2	2R	Orange/white	27	2T	White/Orange
3	3R	Green/white	28	3T	White/green
4	4R	Brown/white	29	4T	White/brown
5	5R	Slate/white	30	5T	White/slate
6	6R	Blue/red	31	6T	Red/blue
7	7R	Orange/red	32	7T	Red/orange
8	8R	Green/red	33	8T	Red/green
9	9R	Brown/red	34	9T	Red/brown
10	10R	Slate/red	35	10T	Red/slate
11	11R	Blue/black	36	11T	Black/blue
12	12R	Orange/black	37	12T	Black/orange
13	13R	Green/black	38	13T	Black/green
14	14R	Brown/black	39	14T	Black/brown
15	15R	Slate/black	40	15T	Black/slate
16	16R	Blue/yellow	41	16T	Yellow/blue
17	17R	Orange/yellow	42	17T	Yellow/orange
18	18R	Green/yellow	43	18T	Yellow/green
19	19R	Brown/yellow	44	19T	Yellow/brown
20	20R	Slate/yellow	45	20T	Yellow/slate
21	21R	Blue/violet	46	21T	Violet/blue
22	22R	Orange/violet	47	22T	Violet/orange
23	23R	Green/violet	48	23T	Violet/green
24	24R	Brown/violet	49	24T	Violet/brown
25	Not used	N/A	50	Not used	N/A

Index



A

- ac delta test 1-6, 2-11
- ac voltage test 1-6
- access-loop parameter 2-4
- ac-delta-capacitance-r-s parameter 2-36
- ac-delta-capacitance-t-r parameter 2-36
- ac-delta-capacitance-t-s parameter 2-36
- ac-delta-resistance-r-s parameter 2-37
- ac-delta-resistance-t-r parameter 2-37
- ac-delta-resistance-t-s parameter 2-37
- ascend cltm-mib groups 3-1
- atu-r parameter 2-36
- AUX connector A-3

B

- background noise test 2-8, 2-16
- background-noise-filter parameter 2-26
- background-noise-termination parameter 2-27
- bridge tap detection 1-3, 2-10
- bridged mode 1-4
- bridge-tap measurement test 1-8
- bridge-tap test 2-9
- bridge-tap-length parameter 2-36
- bridge-tap-number parameter 2-36
- bridge-tap-table parameter 2-36
- btap-measure-length parameter 2-29
- btap-start-length parameter 2-29

C

- calibration function 1-12
- calibration-type parameter 2-27
- capacitance equivalent measurement 1-7
- capacitance test 1-6
- cap-equivalent-r-s parameter 2-35

- cap-equivalent-t- parameter 2-35
- cap-equivalent-t-s parameter 2-35
- clltmAccess SNMP group 3-1
- clt commands 2-1
- CLT module
 - description 1-4
 - operation 1-4
- clt profiles 2-1
- clt-access profile 2-3
- cltActivate command 2-2
- cltActivate External-Loop command 2-3
- cltCmd Bgns command 2-8
- cltCmd BTAP command 2-9
- cltCmd command 2-7
- cltCmd CPEMDM command 2-9
- cltCmd CTONESND command 2-10, 2-11
- cltcmd detaptor command 2-10
- cltCmd DMM command 2-10
- cltcmd dmmacd command 2-11
- cltCmd DMMALL command 2-12
- cltCmd DMMCAP command 2-12
- cltCmd DMMDCD command 2-12
- cltcmd dmmlbal command 2-13
- cltcmd dta command 2-13
- cltCmd FCLLOC command 2-14
- cltcmd impread command 2-14
- cltCmd Impstart command 2-14
- cltcmd impstop command 2-15
- cltcmd inls command 2-15
- cltCmd Lpres command 2-15
- cltcmd measvoice command 2-16
- cltcmd reset command 2-16
- cltCmd RNGR command 2-22
- cltcmd rngr command 2-17
- cltCmd Setbypass 2-17
- cltCmd Setresp 2-17
- cltCmd SHORTLOC command 2-17
- cltcmd signs command 2-18

-
- cltcmd sndvoice command 2-18
 - cltCmd Splitter 2-20
 - cltCmd TDR command 2-20
 - cltCmd TDR set command 2-20
 - cltCmd Tonesend command 2-21
 - cltCmd TSTOP command 2-22
 - cltCmd TTONESEND command 2-21
 - cltcmd vers command 2-22
 - cltCmd VOICEDET command 2-22
 - cltCmdBackgroundNoiseFilter SNMP object 3-5
 - cltCmdBackgroundNoiseTerm SNMP object 3-6
 - cltCmdCalibrationType SNMP object 3-7
 - cltCmdDmmLeads SNMP object 3-5
 - cltCmdImpulseNoiseStartDeadTime SNMP object 3-6
 - cltCmdImpulseNoiseStartDelta SNMP object 3-6
 - cltCmdImpulseNoiseStartMaxCount SNMP object 3-6
 - cltCmdImpulseNoiseStartThresh SNMP object 3-6
 - cltCmdImpulseNoiseStartTimer SNMP object 3-6
 - cltCmdLoopResistanceTemp SNMP object 3-6
 - cltCmdLoopResistanceUnit SNMP object 3-6
 - cltCmdTdrAvg SNMP object 3-7
 - cltCmdTdrGauge SNMP object 3-7
 - cltCmdTdrGetType SNMP object 3-7
 - cltCmdTdrMeasureLen SNMP object 3-8
 - cltCmdTdrStartLen SNMP object 3-8
 - cltCmdTdrUnit SNMP object 3-7
 - cltCmdTdrVp SNMP object 3-7
 - cltCmdToneSendFreq SNMP object 3-7
 - cltCmdToneSendLevel SNMP object 3-7
 - cltDeactivate command 2-3
 - CLTE models 1-2
 - cltmCmdSetRespPeriod 3-10
 - cltmAccessAccessMode SNMP object 3-2
 - cltmAccessAccessResult SNMP object 3-2
 - cltmAccessAccessTerminal SNMP object 3-2
 - cltmAccessAccessTestLoop SNMP object 3-2
 - cltmAccessActivateAccess SNMP object 3-2
 - cltmAccessSlot SNMP object 3-1
 - cltmAccessTestPort SNMP object 3-1
 - cltmAccessTestSlot SNMP object 3-1
 - cltmCmd SNMP group 3-3
 - cltmCmdBridgeTapMeasureLen SNMP object 3-9
 - cltmCmdBridgeTapStart SNMP object 3-9
 - cltmCmdControlToneDslTone SNMP object 3-9
 - cltmCmdControlToneDslType SNMP object 3-9
 - cltmCmdDetapUnit SNMP object 3-12
 - cltmCmdDetapVolt 3-12
 - cltmCmdDmmAcDeltaFrequency SNMP object 3-11
 - cltmCmdDmmAcDeltaPeriodSNMP object 3-11
 - cltmCmdDmmAcDeltaVoltage SNMP object 3-11
 - cltmCmdDmmAllInputImp SNMP object 3-9
 - cltmCmdDmmAllPeriod SNMP object 3-9
 - cltmCmdDmmAllType SNMP object 3-8
 - cltmCmdDmmCapacitancePeriod SNMP object 3-8
 - cltmCmdDmmDcDeltaImpedence SNMP object 3-8
 - cltmCmdDmmDcDeltaPeriod SNMP object 3-8
 - cltmCmdDmmDcDeltaVoltage SNMP object 3-8
 - cltmCmdDmmLongBalFrequency SNMP object 3-11
 - cltmCmdDmmLongBalPeriod SNMP object 3-11
 - cltmCmdDmmLongBalVoltage SNMP object 3-11
 - cltmCmdDmmType SNMP object 3-5
 - cltmCmdFirstCoilLocGauge SNMP object 3-10
 - cltmCmdFirstCoilLocUnit SNMP object 3-10
 - cltmCmdMeasDtaOpMode SNMP object 3-13
 - cltmCmdSendVoiceDigitString SNMP object 3-12
 - cltmCmdSendVoiceDtmfMftone SNMP object 3-12
 - cltmCmdSendVoiceEndFreq SNMP object 3-12
 - cltmCmdSendVoiceFreq SNMP object 3-11
 - cltmCmdSendVoiceFreqIncr SNMP object 3-12
 - cltmCmdSendVoiceLevel SNMP object 3-12
 - cltmCmdSendVoiceOpMode SNMP object 3-11
 - cltmCmdSendVoiceStartFreq SNMP object 3-12
 - cltmCmdSendVoiceTime SNMP object 3-12
 - cltmCmdSendVoiceTonePeriod SNMP object 3-12
 - cltmCmdSetRespOpMode 3-10
 - cltmCmdShortLocUnit SNMP object 3-10
 - cltmCmdShortLocType SNMP object 3-10
 - cltmCmdSlot SNMP object 3-3
 - cltmCmdTestOperation SNMP object 3-3
 - cltmCmdTestSequence SNMP object 3-3
 - cltmCmdTestTimeStamp SNMP object 3-3
 - cltmCmdTraceToneLead SNMP object 3-9
 - cltmCmdTraceToneLevel SNMP object 3-9
 - cltmCmdTraceTonePeriod SNMP object 3-9
 - cltmCmdVoiceSigBgnsMode SNMP object 3-13
 - cltmCmdVoiceSigDetPeriod SNMP object 3-13
 - cltmCmdVoiceSigOpMode SNMP object 3-13
 - cltmRslt SNMP group 3-14
 - cltmRsltBridgeTapConfidence SNMP object 3-19

-
- cltmRsltBridgeTapDistance SNMP object 3-18
 - cltmRsltBridgeTapIndex SNMP object 3-18
 - cltmRsltBridgeTapLength SNMP object 3-18
 - cltmRsltBridgeTapLoopLen SNMP object 3-17
 - cltmRsltBridgeTapNumber SNMP object 3-16
 - cltmRsltBridgeTapSlot SNMP object 3-18
 - cltmRsltBridgeTapTable SNMP object 3-17
 - cltmRsltCoilDetectionNumCoil SNMP object 3-15
 - cltmRsltCpeDetect SNMP object 3-16
 - cltmRsltDetapNumTaps SNMP object 3-19
 - cltmRsltDetapTapLength SNMP object 3-19
 - cltmRsltDistLevDistance SNMP object 3-18
 - cltmRsltDistLevIndex SNMP object 3-17
 - cltmRsltDistLevLevel SNMP object 3-18
 - cltmRsltDistLevSlot SNMP object 3-17
 - cltmRsltDistLevTable SNMP object 3-17
 - cltmRsltDmmAcDeltaCapacitanceRS SNMP object 3-19
 - cltmRsltDmmAcDeltaCapacitanceTR SNMP object 3-19
 - cltmRsltDmmAcDeltaCapacitanceTS SNMP object 3-19
 - cltmRsltDmmAcDeltaResistanceRS SNMP object 3-19
 - cltmRsltDmmAcDeltaResistanceTR SNMP object 3-19
 - cltmRsltDmmAcDeltaResistanceTS SNMP object 3-19
 - cltmRsltDmmallRS SNMP object 3-16
 - cltmRsltDmmallTR SNMP object 3-16
 - cltmRsltDmmallTS SNMP object 3-16
 - cltmRsltDmmCapacitanceRS SNMP object 3-16
 - cltmRsltDmmCapacitanceTR SNMP object 3-16
 - cltmRsltDmmCapacitanceTS SNMP object 3-16
 - cltmRsltDmmDcDeltaResistanceRS SNMP object 3-16
 - cltmRsltDmmDcDeltaResistanceTR SNMP object 3-16
 - cltmRsltDmmDcDeltaResistanceTS SNMP object 3-16
 - cltmRsltDmmDcDeltaVoltageRS SNMP object 3-16
 - cltmRsltDmmDcDeltaVoltageTS SNMP object 3-16
 - cltmRsltDmmLbalOutputDb SNMP object 3-19
 - cltmRsltDmmResult SNMP object 3-14
 - cltmRsltDtmfMfStatus SNMP object 3-19
 - cltmRsltFirstCoilLocation SNMP object 3-17
 - cltmRsltFreqDbDbLevel SNMP object 3-18
 - cltmRsltFreqDbFreq SNMP object 3-18
 - cltmRsltFreqDbIndex SNMP object 3-18
 - cltmRsltFreqDbSlot SNMP object 3-18
 - cltmRsltFreqDbTable SNMP object 3-17
 - cltmRsltLoopResistance SNMP object 3-14
 - cltmRsltLoopResistanceLenAwg22 SNMP object 3-14
 - cltmRsltLoopResistanceLenAwg24 SNMP object 3-15
 - cltmRsltLoopResistanceLenAwg26 SNMP object 3-15
 - cltmRsltMeasDtaTestRslt SNMP object 3-20
 - cltmRsltMeasVoiceAutoMode SNMP object 3-19
 - cltmRsltMeasVoiceBgnsRslt SNMP object 3-20
 - cltmRsltMeasVoiceSgnsRslt SNMP object 3-20
 - cltmRsltMeasVoiceToneFreq SNMP object 3-20
 - cltmRsltMeasVoiceToneLevel SNMP object 3-20
 - cltmRsltRingerDetect SNMP object 3-16
 - cltmRsltShortLocation SNMP object 3-17
 - cltmRsltSlot SNMP object 3-14
 - cltmRsltSplitterRslt 3-19
 - cltmRsltTestResultsSequence SNMP object 3-14
 - cltmRsltTestResultStatus SNMP object 3-14
 - cltmRsltTestResultTimeStamp SNMP object 3-14
 - cltmRsltVoiceDetection SNMP object 3-17
 - cltm-slot parameter 2-24, 2-33
 - clt-result profile 2-32
 - cltRsltGetSampleCount SNMP object 3-15
 - cltRsltGetTdrAutomaticFaultDist SNMP object 3-15
 - cltRsltHwRevision SNMP object 3-15
 - cltRsltImpulseNoiseReadHighThresh SNMP object 3-15
 - cltRsltImpulseNoiseReadLowThresh SNMP object 3-15
 - cltRsltImpulseNoiseReadMidThresh SNMP object 3-15
 - cltRsltRcvToneFreq SNMP object 3-15
 - cltRsltRcvToneLev SNMP object 3-15
 - cltRsltSwRevision SNMP object 3-15
 - coil detection test 1-8
 - coil-detection-coil-count parameter 2-34
 - command-line interface 2-1
 - connector pinouts A-2
 - connectors
 - AUX connector A-3
 - SERIAL A-2
 - TEST PAIR A-3
 - control tone function 2-10, 2-11
 - copper loop access 2-2

ctone-tone parameter 2-29

ctone-type parameter 2-29

D

dc delta measurement test 1-6

dc voltage tests 1-6

dc-delta-potential-r-s parameter 2-35

dc-delta-potential-t-s parameter 2-35

dc-delta-resistance-r-s parameter 2-35

dc-delta-resistance-t-r parameter 2-35

dc-delta-resistance-t-s parameter 2-35

detaptor function 2-10

detaptor-num-taps parameter 2-37

detaptor-tap-length parameter 2-37

detap-unit parameter 2-31

detap-voltage parameter 2-31

detect ATU-R function 1-11, 2-9

detect ringer function 1-11, 2-22

Dial tone testing 1-11

dialtone test 2-13

DMM ac delta measurement 1-6

DMM capacitance equivalent test 2-12

DMM DC delta measurement test 2-12

DMM longitudinal balance 1-6

DMM longitudinal balance test 2-13

DMM test 2-10

dmmacd-frequency parameter 2-30

dmmacd-period parameter 2-30

dmmacd-voltage parameter 2-30

DMMALL test 2-12

dmmall-input-imp parameter 2-29

dmmall-period parameter 2-28

dmmall-r-s parameter 2-36

dmmall-t-r parameter 2-35

dmmall-t-s parameter 2-35

dmmall-type parameter 2-28

dmmcap-period parameter 2-28

dmmgcd-impedance parameter 2-28

dmmgcd-period parameter 2-28

dmmgcd-voltage parameter 2-28

dmmibal-frequency parameter 2-30

dmm-ibal-output-db parameter 2-37

dmmibal-period parameter 2-30

dmmibal-voltage parameter 2-30

dmm-lead parameter 2-26

dmm-result parameter 2-33

dmmsoak-configuration parameter 2-30

dmmsoak-interval parameter 2-30

dmmsoak-resistance parameter 2-30

dmmsoak-voltage parameter 2-30

dmm-type parameter 2-26

download command 1-12

E

E1 LIMs 2-4, 3-2

examples

loop access 2-3

multiple Stinger units 2-6

F

fcloc-gauge parameter 2-29

fcloc-unit parameter 2-29

first coil location test 1-8

first load coil detection function 2-14

first-coil-location parameter 2-36

functions 1-11

H

hardware version 2-22

hardware-revision parameter 2-34

I

impulse noise test 1-7, 2-14

impulse-noise- start-delta parameter 2-27

impulse-noise-read-high-threshold parameter
2-34

impulse-noise-read-low-threshold parameter
2-34

impulse-noise-read-mid-threshold parameter
2-34

impulse-noise-start-dead-time parameter 2-27

impulse-noise-start-max-count parameter 2-27

impulse-noise-start-thresh parameter 2-27

impulse-noise-start-time parameterr 2-27

insertation loss test 2-15

insertion loss test 1-8

installation 1-3

L

- line length measurement 1-2
- load coil detection 1-2
- longitudinal balance test 1-6, 2-13
- looking out mode 1-4
- loop access 2-2, 2-3
- loop parameter 2-3
- loop resistance test 2-15
- loop resistance tests 1-9
- loop tests, metallic
 - double-ended 1-2
 - single-ended 1-2
- LoopCare system 1-3
- loop-resistance parameter 2-33
- loop-resistance-length-1 parameter 2-34
- loop-resistance-length-2 parameter 2-34
- loop-resistance-length-3 parameter 2-34
- loop-resistance-temp parameter 2-27
- loop-resistance-unit parameter 2-27

M

- measdta-opmode parameter 2-32
- measdta-test-result parameter 2-37
- measvoice-auto-result parameter 2-37
- measvoice-bgns-mode parameter 2-31
- measvoice-bgns-result parameter 2-37
- measvoice-det-period parameter 2-31
- measvoice-dtmf-mf-status parameter 2-37
- measvoice-opmode parameter 2-31
- measvoice-sgns-result parameter 2-37
- measvoice-tone-freq parameter 2-37
- measvoice-tone-level parameter 2-37
- metallic fault tests 1-3
- metallic loop testing 1-2
- MIB groups 3-1
- models, CLTE 1-2
- multiple Stinger units, testing 2-5

N

- noise measurement 1-3

P

- parameters

- access-loop 2-4
 - loop 2-3
 - setbypass 2-8
 - setresp 2-8
 - splitter 2-8
- performing a test 1-12
- physical specifications A-1
- pinouts, connectors A-2
- prequalification tests 1-2
- psd-frequency-level parameter 2-35

R

- rcv-tone-frequency parameter 2-34
- rcv-tone-level parameter 2-34
- receive Tone function 1-11
- reset CLT 2-16
- reset command function 1-12
- responder mode 1-12
- results group 3-14
- ringer detection 2-17
- ringer parameter 2-36
- running a test 1-12

S

- send control tone function 1-11
- send tone function 1-11
- send trace tone function 1-11
- Send voice signal 1-11
- sendvoice-decibal-level parameter 2-31
- sendvoice-digit-string parameter 2-31
- sendvoice-dtmf-mf-tone parameter 2-31
- sendvoice-end-freq parameter 2-31
- sendvoice-freq-increase parameter 2-31
- sendvoice-frequency parameter 2-30
- sendvoice-op-mode parameter 2-30
- sendvoice-start-freq parameter 2-31
- sendvoice-time-duration parameter 2-31
- sendvoice-tone-period parameter 2-31
- SERIAL connector A-2
- set-bypass (32) 3-4
- setbypass parameter 2-8
- set-bypass-test 2-26
- setresp parameter 2-8
- setresp-mode 2-30
- setresp-mode-period 2-30
- set-responder-test 2-26

Index

T

- short circuit location 1-8
- short circuit location function 2-17
- short-location parameter 2-36
- shortloc-gauge parameter 2-29
- shortloc-type parameter 2-30
- shortloc-unit parameter 2-29
- signal to noise test 2-18
- signal-to-noise ratio (SNR) 1-9
- single CLT module use 2-5
- SNMP groups
 - cltmAccess 3-1
 - cltmCmd 3-3
 - cltmRslt 3-14
- soak-resistance-r-s parameter 2-37
- soak-resistance-t-s parameter 2-37
- software version 2-22
- software-revision parameter 2-34
- specifications A-1
- splitter
 - bypass 1-3, 1-12
 - detection 1-8
- Splitter bypass 1-12
- Splitter detection 1-8
- splitter parameter 2-8
- splitter-detect (33) 3-4
- splitter-detect-test 2-26
- splitter-det-result 2-36
- stop tone function 1-11, 2-22
- subscriber dialtone test 2-13

T

- T1 LIMs 2-4
- T1LIMs 3-2
- TDR parameter set 2-20
- TDR test 2-20
- TDR test modes 1-10
- TDR test parameters 1-10
- tdr tests 1-9
- tdr-automatic-fault-distance parameter 2-34
- tdr-avg parameter 2-28
- tdr-distance-level parameter 2-35
- tdr-gauge parameter 2-27
- tdr-get-type parameter 2-28
- tdr-manual-sample-count parameter 2-34
- tdr-measurement-length parameter 2-28
- tdr-start-distance parameter 2-28
- tdr-unit parameter 2-27

- tdr-vp parameter 2-28
- test access 2-2, 2-3
- test modes 1-4
- TEST PAIR connector A-3
- test selection 2-7
- testing 1-12
- test-operation parameter 2-26
- test-result-sequence parameter 2-33
- test-result-status parameter 2-33
- test-result-time-stamp parameter 2-33
- tests
 - ac voltage 1-6
 - bridge tap detection 1-3
 - bridge-tap measurement 1-8
 - capacitance 1-6
 - capacitance equivalent 1-7
 - coil detection 1-8
 - dc delta measurement 1-6
 - dc voltage 1-6
 - DMM 1-1
 - first coil location 1-8
 - impulse noise 1-7
 - insertion loss 1-8
 - line length measurement 1-2
 - line tests 1-1, 1-7
 - load coil detection 1-2
 - loop resistance tests 1-9
 - metallic fault 1-3
 - noise measurement 1-3
 - short circuit location 1-8
 - signaling 1-1
 - signal-to-noise 1-9
 - TDR 1-1, 1-9
 - tone 1-1, 1-11
 - wideband noise 1-7
- test-sequence parameter 2-24
- test-time-stamp parameter 2-24
- tonesend function 2-21
- tone-send-frequency parameter 2-27
- tone-send-level parameter 2-27
- tone-send-period parameter 2-27
- trace tone function 2-21
- ttone-lead parameter 2-29
- ttone-level parameter 2-29
- ttone-period parameter 2-29

U

- using clt commands 2-1
- using clt profiles 2-1
- using the command-line interface 2-1

V

version 2-22
version function 1-12
voice detection function 1-11, 2-22
voice send test 2-18
Voice signal detection 1-11
voice signal test 2-16
voice tests 1-11
voice-detection parameter 2-36

W

wideband noise test 1-7