

SCSA HARDWARE MODEL

AEB HARDWARE MODEL

PEB HARDWARE MODEL

# BRI/2VFD

## BRI and Media Processing Board with Voice, Fax, and Data

The BRI/2VFD™ board is ideal for OEMs, application developers and integrators that are looking to provide CT solutions to the rapidly growing European BRI market. The BRI/2VFD product is a two S<sub>0</sub> Euro-ISDN Basic Rate Interface (BRI) product that supports voice, Group 3 fax, and data communication. The BRI/2VFD board is specifically designed for tight integration with the new generation of standard Euro-ISDN switches and supports any combination of four simultaneous voice, fax, or data instances in a single PCI slot. The board incorporates many powerful new features including support for

- Four instances of Dialogic SpringWare™-based media and signal processing
- Four instances of ISDN BRI B channel data processing with ML/PPP support for RAS applications
- ISDN BRI D channel signaling support, including support for caller/called party ID, message waiting, subaddressing, advice of charge, and other important ISDN supplementary services, such as overlap send and overlap receive
- Simplified hardware installation without the need to set jumpers and switches

You can build tightly integrated messaging systems with the BRI/2VFD board that give customers unrestricted use of voice, fax and data processing on the same call. The board's support for 64 Kb/s B channel data makes the product ideal for small office remote access server (RAS) solutions. The BRI/2VFD board provides everything required for building integrated call processing and fax services scalable from two BRI ports to eight ports and beyond, when using other Dialogic BRI products.

The BRI/2VFD board is built on the proven dual-processor architecture pioneered by Dialogic. This configuration combines a Motorola digital signal processor (DSP) with an Intel®-compatible control processor. The result is a balanced processing capacity coupled with robust software architecture that enables advanced signal computing. The architecture runs Dialogic SpringWare downloadable signal and call processing firmware, which provides an advanced set of



### FEATURES AND BENEFITS

- Two onboard independent Euro-ISDN BRI S/T interface ports support CT applications for small to medium-sized businesses
- Voice, Group 3 fax, and BRI data processing on each B channel provide a true universal telephony solution in a single PCI slot
- Specially designed for tight integration with standard Euro-ISDN switches; eliminates the need to run expensive analog lines from the switch to the server
- Euro-ISDN supplementary services, including caller/called party ID, message waiting, sub-addressing, and advice of charge, provide tighter integration with standard Euro-ISDN BRI switches and add value to server-based applications
- Dialogic DSP-based fax provides four simultaneous 14,400 b/s (v.17) transmit and 9,600 b/s (v.29) receive fax instances with ITU-T Group 3 and ETSI NET/30 compliance

**Dialogic Corporation**  
1515 Route Ten • Parsippany, NJ 07054  
1-973-993-3000 • fax: 1-973-993-3093  
<http://www.dialogic.com>

**Dialogic North American Sales**  
1-800-755-4444  
or 1-973-993-3030  
fax orders: 1-973-631-9631  
[sales@dialogic.com](mailto:sales@dialogic.com)

**Dialogic Latin America & Caribbean**  
(Buenos Aires)  
54-11-4328-1531  
fax: 54-11-4328-5425  
[dla.sales@dialogic.com](mailto:dla.sales@dialogic.com)

**Dialogic Europe**  
(Brussels)  
32-2-712-4311  
fax: 32-2-712-4300  
[dte.sales@dialogic.com](mailto:dte.sales@dialogic.com)

**Dialogic Asia/Pacific**  
(Singapore)  
65-339-9833  
fax: 65-339-9211  
[asia.sales@dialogic.com](mailto:asia.sales@dialogic.com)

## FEATURES AND BENEFITS (cont.)

- Dialogic DSP-based fax is fully compliant with the ITU-T T.4 and T.30 specifications to ensure compatibility with fax machines worldwide
- Dialogic SpringWare™ provides easy feature enhancement and field-proven performance based on over three million installed ports
- PerfectDigit™ provides reliable DTMF (touchtone) detection during voice playback — lets callers “type-ahead” through menus
- SCSA™ SCbus™ connectivity enables applications requiring switching and allows access to additional hardware resources
- H.100 connector allows for easy future expansion to the new industry-standard CT Bus™
- Hardware installation is simplified by eliminating DIP switches and jumper settings and enabling software-controlled configuration
- Board ID/slot number can be read from a hexadecimal display located on the PCB bracket, allowing board identification without removal from the chassis
- Future support for host PC-based speech solutions, including text-to-speech (TTS) software and automatic speech recognition (ASR)
- C language application programming interface (API) for Windows NT® shortens the development cycle so you can get your applications to market faster
- Configure up to four boards in a single chassis PCI bus or mixed PCI/ISA bus, for easy and cost-effective system expansion on the best computing platform for your needs

## APPLICATIONS

- Voice messaging
- Unified messaging
- Integrated voice mail and fax mail
- Integrated voice/fax response
- Small business RAS

call processing features, including selectable rate, high-quality voice coding with speed control, and outstanding DTMF detection with cut through.

## Typical Unified Messaging Solution

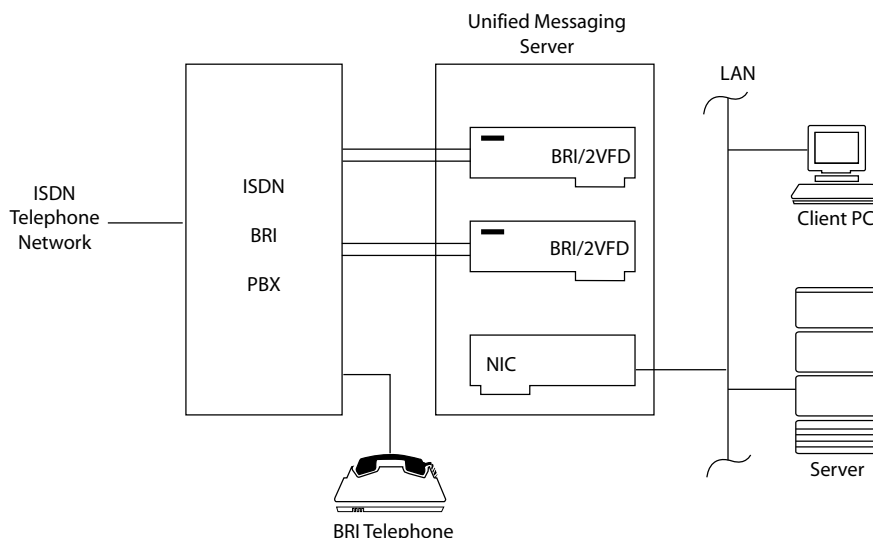

## CONFIGURATIONS

Use the BRI/2VFD board to build sophisticated, computer telephony (CT) systems to which capabilities such as speech recognition, fax, and text-to-speech (TTS) can be added. The BRI/2VFD board shares a common hardware and firmware architecture with other Dialogic SCbus boards for maximum flexibility and scalability. You can add features and grow the system while protecting your investment in hardware and application code. With only minimum modifications, applications can be easily ported to lower or higher line-density platforms.

The BRI/2VFD board installs in any PCI-based Pentium™ personal computer or server (PCI bus or mixed PCI/ISA) or compatible computer platform. The board provides everything required for building integrated voice and data solutions scalable from two to eight ports.

Applications developed to run on Dialogic high-density Primary Rate Interface (PRI) products will support a similar BRI/2VFD board configuration with minor modification.

## Dialogic Corporation

1515 Route Ten • Parsippany, NJ 07054  
1-973-993-3000 • fax: 1-973-993-3093  
<http://www.dialogic.com>

## Dialogic North American Sales

1-800-755-4444  
or 1-973-993-3030  
fax orders: 1-973-631-9631  
[sales@dialogic.com](mailto:sales@dialogic.com)

## Dialogic Latin America &amp; Caribbean

(Buenos Aires)  
54-11-4328-1531  
fax: 54-11-4328-5425  
[dla.sales@dialogic.com](mailto:dla.sales@dialogic.com)

## Dialogic Europe

(Brussels)  
32-2-712-4311  
fax: 32-2-712-4300  
[dte.sales@dialogic.com](mailto:dte.sales@dialogic.com)

## Dialogic Asia/Pacific

(Singapore)  
65-339-9833  
fax: 65-339-9211  
[asia.sales@dialogic.com](mailto:asia.sales@dialogic.com)

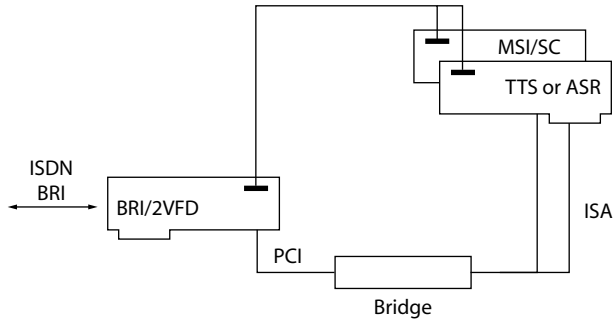

#### A Mixed PCI/ISA Configuration Example

The BRI/2VFD board can operate within a mixed chassis containing Dialogic PCI and ISA products. The board's forward-looking design incorporates the new H.100 connector to simplify the connection to next-generation CT Bus products. The board can also connect to existing SCbus products through the use of an optional CT Bus/SCbus adapter. The adapter provides both SCbus and H.100 physical connectors required to link the BRI/2VFD board to current SCbus products.

#### SOFTWARE SUPPORT

The Dialogic System Software and Software Development Kit for Windows NT (native) provides support for the BRI/2VFD board. This package contains a set of tools for developing complex multichannel applications. The BRI/2VFD DSP-based fax interface is designed to work consistently with Dialogic standard Release 4.X voice and call processing interfaces. ■

## FUNCTIONAL DESCRIPTION

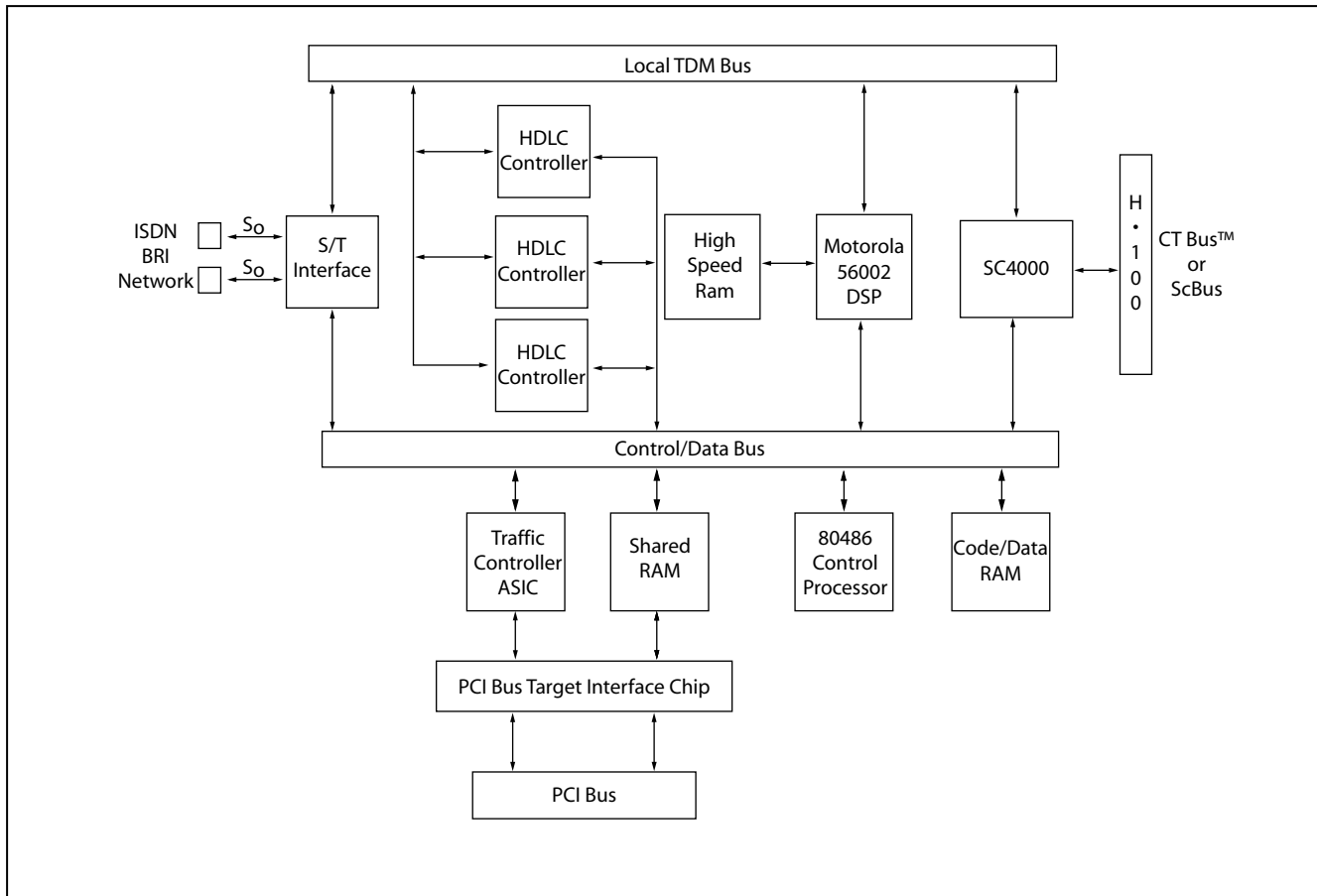

The BRI/2VFD board is a two  $S_0$  port (four channel) ISDN BRI voice/data processing board with Group 3 fax support. Each port is a four-wire S/T interface to the ISDN network, supporting two 64 Kb/s B channels for voice/data transmission, and one 16 Kb/s D channel for use as a signaling channel. The BRI/2VFD board is designed around the proven Dialogic dual-processor architecture and consists of three main sections: the ISDN BRI network interface, the voice and fax processing engine, and the data processing engine.

The ISDN network interface is the electrical and functional link between the BRI/2VFD board and ISDN BRI network. The purpose of this interface is to transmit and receive voice, fax, data, and signaling information to and from

the ISDN network.

In the receive mode, each of the two S/T interfaces converts network ISDN BRI to PCM data and applies the incoming bit stream to the SC4000 chip. The SC4000 ASIC distributes the data onto pre-assigned time slots on the local TDM bus. Voice transmissions (and fax) are routed to the DSP voice processing engine. Data and signaling information are routed to the data processing engine.

In transmit mode, the DSP voice processing engine and data processing engine transmit voice and data respectively in different assigned time slots to the SC4000 device. The voice/data is passed on the local TDM bus to the S/T interface, and is then transmitted to the ISDN network.

The SC4000 ASIC also serves to exchange voice and fax between a time slot on the local TDM bus and a time slot on the SCbus or CT Bus. The BRI/2VFD board can transmit or receive voice or fax information to and from an external device over the SCbus or CT Bus.

The BRI/2VFD board processes voice with a DSP voice processing engine. The DSP resource receives voice and fax via the SC4000 chip. The DSP processes the digitized voice data using the SpringWare firmware loaded in code/data RAM. The DSP performs the following signal analysis and operations on this incoming data:

- automatic gain control to compensate for variations in the level of the incoming audio signal

## FUNCTIONAL DESCRIPTION

- applies an ADPCM (adaptive differential pulse code modulation) or PCM (pulse code modulation) algorithm to compress the digitized voice and save disk storage space
- detects the presence of tones — DTMF, MF, or an application-defined single or dual tone
- silence detection to determine whether the line is quiet and the caller is not responding

For outbound voice, the DSP performs the following operations:

- expands stored, compressed audio data for playback
- adjusts the volume and rate of speed of playback upon application or user request
- generates tones — DTMF, MF, or any application-defined general-purpose tone

When recording speech, the DSP can use different digitizing rates from 24 to 64 Kb/s as selected by the application for the best speech quality and most efficient storage. The digitizing rate is selectable on a channel-by-channel basis and can be changed each time a record or play function is initiated. The DSP-processed speech is transmitted via the control processor to the host PC for disk storage. When replaying a stored file, the processor retrieves the voice information from

the host PC and passes it to the DSP, which then converts the file into digitized voice. The DSP uses the SC4000 and local TDM bus circuitry to send the digitized voice responses to the caller via the S/T digital line interface.

The BRI/2VFD board supports data and signal processing using a data processing engine. The data processing engine is made up of three HDLC controller devices. These controllers have been designed to implement data links using HDLC protocol. Each controller supports two independent full-duplex HDLC channels. One of the three HDLC controllers handles the D or ISDN signaling channels for both BRI ports. The second and the third controllers handle B channel data on the first and second BRI port respectively.

An onboard control processor accomplishes the flow of information between the voice and data processing engines and the host PC. The control processor controls all operations of the BRI/2VFD board and interprets and executes commands from the host PC. The processor handles real-time events, manages data flow to the host PC to provide faster system response time, reduces PC host processing demands, processes DTMF and telephony signaling before passing them to the application, and frees the DSP to

perform signal processing.

Communications between the control processor and the host PC is via the shared RAM that acts as an input/output buffer, increasing the efficiency of disk file transfers. The RAM interfaces with the host PC via the PCI bus. All operations are interrupt-driven to meet the demands of real-time systems. When the system is initialized, SpringWare firmware is downloaded from the host PC to the onboard code/data RAM and DSP RAM to control all board operations. This downloadable firmware gives the board all of its intelligence and enables easy feature enhancement and upgrades.

The traffic controller ASIC (TCA) is the control processor interface that handles all peripheral devices (SC4000, DSP, HDLCs, ISDN network interface) and host PC functions across the PCI bus. The BRI/2VFD board's hardware is Plug and Play enabled. The board ID/slot number configuration is handled exclusively by software, using the Dialogic Configuration Manager (DCM). The assigned board ID/slot number is presented on a hexadecimal display located on the PCB bracket. ■

## ■ Technical Specifications\*

Number of ports	Two S <sub>0</sub>
Maximum BRI/2VFD boards/system	4 (number may be limited by application and system performance)
ISDN BRI network interface	Onboard S/T interface
Resource sharing bus	SCbus with H.100 connector
Control microprocessor	Intel® 80486 GX @ 28.5 MHz, 0 wait state
Digital signal processor	Motorola DSP56002 @ 65.5 MHz, with 128 K word private, 0 wait state SRAM

### HOST INTERFACE:

Bus compatibility	PCI (complies with PCISIG Bus Specification, Rev. 2.1)
Bus speed	33 MHz maximum
Bus mode	32-bit to 16-bit conversion in target mode
Shared memory	64 KB page
I/O ports	None

### TELEPHONE INTERFACE:

Technical specification	Complies with Euro-ISDN BRI CTR-3
Connectors	2 RJ-45
Telephony bus connector	H.100-style 68-pin fine pitch card edge connector

### ISDN BRI CALL SUPPORT:

Protocol support	Euro-ISDN BRI
Called/calling party identification	ETS 300 089, ETS 300 090, ETS 300 091, ETS 300 092, ETS 300 093, ETS 300 094, ETS 300 095, ETS 300 097
Sub-addressing	ETS 300 059, ETS 300 060, ETS 300 061
Hold, receive, call transfer	ETS 300 367, ETS 300 368, ETS 300 369, ETS 300 139, ETS 300 140, ETS 300 141
Advice of charge	ETS 300 178, ETS 300 179, ETS 300 180, ETS 300 181, ETS 300 182
Message waiting	ETS 300 650, ETS 300 745
Channel-related and special bearer capability (BC)	ETS 300 XXX (specific supplementary service numbers to be provided as they become available)

### FAX SUPPORT:

Fax modem	Dialogic DSP-based
Fax instances (per board)	4 (simultaneous)
Fax compatibility	ITU-T G3 compliant (T.4, T.30), ETSI NET/30 compliant
Data rate (maximum)	14,400 b/s (V.17) transmit and 9,600 b/s receive (V.29)
Compression modes	MH (Modified Huffman), MR (Modified READ)
File data formats	TIFF/F (Tagged Image File Format) for transmit/receive
ASCII-to-fax conversion	MH and ASCII text transmit
Error correction	Host-based conversion
	Detection, reporting, and correction of faulty scan lines

### DATA SUPPORT:

Data type	HDLC framed
Data instances (per board)	4 (simultaneous)
Data instances (per chassis)	4 (number may be limited by application and system performance)
Data protocols	Point-to-Point (PPP), Multi-Link/Point-to-Point Protocol (ML/PPP)
Data rate (uncompressed)	64 Kb/s transmit and receive per B channel using PPP, 128 Kb/s using two B channels and Multi-Link PPP
Compression modes	Not supported

## ■ Technical Specifications\* (cont.)

### POWER REQUIREMENTS:

Total power consumption	< 7.5 W
+5 VDC	< 1.4 mA
+12 VDC	< 10 mA
-12 VDC	0 mA
Operating temperature	0° C to +50° C
Storage temperature	-20° C to +70° C
Humidity	8% to 80% noncondensing
Form factor	PCI short card, 6.875 in. long, 0.79 in. wide (total envelope), 4.2 in. high (including edge connector)

### SAFETY AND EMI CERTIFICATIONS:

United States	FCC part 68 ID#: EBZUSA-24729-CE-N UL: E96804
Canada	Industry Canada: 8858280A ULC: E96804
Europe	CE marked and CTR-3 approved, EN41003 (safety), EN60950 (safety), EN55022 Class B (emissions), EN50082-1 (immunity)
Warranty	Three years standard

## ■ SpringWare Technical Specifications\*

### AUDIO SIGNAL:

Usable receive range	-40 to +2.5 dBm0 nominal, configurable by parameter**
Automatic gain control	Application can enable/disable. Above -18 dBm0 results in full scale recording, configurable by parameter.**
Silence detection	-38 dBm0 nominal, software adjustable**
Transmit level (weighted average)	-9 dBm0 nominal, configurable by parameter**
Transmit volume control	40 dB adjustment range, with application-definable increments and legal limit cap
Frequency response	24 Kb/s: 300 Hz to 2600 Hz $\pm$ 3 dB 32 Kb/s: 300 Hz to 3400 Hz $\pm$ 3 dB 48 Kb/s: 300 Hz to 2600 Hz $\pm$ 3 dB 64 Kb/s: 300 Hz to 3400 Hz $\pm$ 3 dB

### AUDIO DIGITIZING:

24 Kb/s	OKI ADPCM @ 6 kHz sampling
32 Kb/s	OKI ADPCM @ 8 kHz sampling
48 Kb/s	$\mu$ -law PCM @ 6 kHz sampling
64 Kb/s	$\mu$ -law PCM @ 8 kHz sampling
Digitization selection	Selectable by application on function call-by-call basis
Playback speed control	Pitch controlled; available for 24 and 32 Kb/s data rates; adjustment range: $\pm$ 50%; adjustable through application or programmable DTMF control.

### DTMF TONE DETECTION:

DTMF digits	0 to 9, *, #, A, B, C, D per Bellcore LSSGR Section 6
Dynamic range	-36 dBm0 to -3 dBm0 per tone, configurable by parameter**
Minimum tone duration	40 ms, can be increased with software configuration
Interdigit timing	Detects like digits with a >40 ms interdigit delay. Detects different digits with a 0 ms interdigit delay.
Acceptable twist and frequency variation	Meets Bellcore LSSGR Section 6 and EIA RS464A requirements
Noise tolerance	Meets Bellcore LSSGR Section 6 requirements for Gaussian, impulse, and power line noise tolerance
Cut through	Local echo cancellation permits 100% detection with a >4.5 dB return loss line
Talk off	Detects less than 20 digits while monitoring Bellcore TR-TSY-000763 standard speech tapes (LSSGR requirements specify detecting no more than 470 total digits). Detects 0 digits while monitoring MITEL speech tape #CM 7291.

### GLOBAL TONE DETECTION™:

Tone type	Programmable for single or dual
Maximum number of tones	Application dependent
Frequency range	Programmable within 300 to 3500 Hz
Maximum frequency deviation	Programmable in 5 Hz increments
Frequency resolution	$\pm$ 5 Hz — Separation of dual frequency tones is limited to 62.5 Hz at a signal-to-noise ratio of 20 dB
Timing	Programmable cadence qualifier, in 10 ms increments
Dynamic range	Programmable, default set at -36 dBm0 to -0 dBm0 (single tone) -3 dBm0 (dual tone)

## ■ SpringWare Technical Specifications\*

### GLOBAL TONE GENERATION™:

Tone type	Generate single or dual tones
Frequency range	Programmable within 200 to 4000 Hz
Frequency resolution	1 Hz
Duration	10 msec increments
Amplitude	-43 dBm0 to -3 dBm0 per tone nominal, programmable

### MF SIGNALING:

R1	
MF digits	0 to 9, KP, ST, ST1, ST2, ST3 per Bellcore LSSGR Sec 6, TR-NWT-000506 and CCITT Q.321
Transmit level	Complies with Bellcore LSSGR Sec 6, TR-NWT-000506
Signaling mechanism	Complies with Bellcore LSSGR Sec 6, TR-NWT-000506
Dynamic range for detection	-25 dBm0 to -3 dBm0 per tone
Acceptable twist	6 dB
Acceptable frequency variation	Less than $\pm 1$ Hz

\* All specifications are subject to change without notice.

\*\* Configurable to meet country specific PTT requirements. Actual specification may vary from country to country for approved products.

### HARDWARE SYSTEM REQUIREMENTS

- Pentium® PCI bus or mixed PCI/ISA bus PC or compatible computer
- Operating system hardware requirements vary according to the number of channels being used
- System must comply with PCISIG Bus Specification Rev. 2.1 or later.

### ADDITIONAL COMPONENTS

- Optional multidrop SCbus or CT Bus cables
- Optional CT Bus/SCbus Adapter