

# COURIER™

**I-modems with x2**

**Getting Started**

---

The material contained in this manual is for information purposes only and is subject to change without notice.

No part of this document may be reproduced, transmitted, transcribed, or stored in a retrieval system in any form or by any means, mechanical, magnetic, electronic, optical, chemical, or otherwise without the written permission of U.S. Robotics.

U.S. Robotics, the U.S. Robotics logo, V.Everything, and Adaptive Speed Leveling are registered trademarks and Courier and x2 are trademarks of 3Com Corp. Microsoft, MS-DOS, Windows, and Windows NT are registered trademarks of Microsoft Corporation. AppleTalk and Macintosh are trademarks of Apple Computer, Inc.

Any trademarks, trade names, service marks, or service names owned or registered by any other company and used in this manual are the property of their respective companies.

U.S. Robotics assumes no responsibility for errors or omissions in this manual. Nor does U.S. Robotics make any commitment to update the information contained herein.

---

©1997 U.S. Robotics PCD s.a.r.l  
Cityparc, 3 rue Lavoisier  
59650 Villeneuve d'Ascq  
France

## Installing Your Courier I-modem

<b>To install your</b>	<b>Go to</b>
Internal modem	Page 5
External modem into a PC	Page 23
External modem to a Macintosh	Page 23

## Configuring Your Courier I-modem

<b>To configure your Courier for</b>	<b>Go to</b>
Windows 95®	I-modem <i>Reference Guide</i>
Macintosh®	I-modem <i>Reference Guide</i>
Other operating systems	I-modem <i>Reference Guide</i>

## Using LEDs, Jumpers, and DIP Switches

<b>To do this</b>	<b>Go to</b>
Locate jumpers	Page 8
Modify jumper settings (internal Courier)	Page 11
Locate DIP switches on the internal Courier	Page 8
Modify DIP switch settings on the internal Courier	Page 17
Locate DIP switches on the external Courier	Page 28
Modify DIP switch settings on the external Courier	Page 28
Understand the LEDs	Page 55

# Contents

<b>Introduction .....</b>	<b>1</b>
How to Use this Guide .....	1
Contacting U.S. Robotics .....	1
Features .....	2
I-modem and ISDN .....	3
Different I-modem S/T Versions .....	3
How Does the I-modem Fit In? .....	4
<b>Installing the Internal I-modem .....</b>	<b>5</b>
Requirements .....	5
Package Contents .....	6
Important! .....	7
Installing Your Internal I-modem .....	8

Step One: Configure your COM port and IRQ settings.....	10
<i>Default COM/IRQ Jumper Settings</i> .....	10
<i>Using COM Ports with Different Operating Systems</i> .....	11
<i>Changing Jumper Settings</i> .....	11
<i>Setting Jumpers for a Specific COM Port</i> .....	13
<i>Setting Jumpers for a Specific IRQ</i> .....	14
Step Two: Configure S/T Termination Settings with Jumpers.....	15
<i>Default S/T Termination Jumper Settings</i> .....	16
Step Three: Configuring with DIP Switches.....	17
Step Four: Inserting the Modem.....	19
Step Five: Connecting the Cables.....	22
<b>Installing the External I-modem.....</b>	<b>23</b>
What You Need.....	23
Package Contents.....	24
Installing Your External I-modem.....	26
<i>Step One: Connecting the Serial Cable</i> .....	26
<i>Step Two: Configure S/T Termination Settings</i> .....	27
<i>Step Three: Configure with DIP Switches</i> .....	28
<i>Step Four: Connecting the ISDN Cable</i> .....	30
<i>Step Five: Connect the Power Cable</i> .....	31

<b>Testing the Connection between the Computer and I-modem .....</b>	<b>32</b>
<b>Installing the Configuration Manager .....</b>	<b>37</b>
What You Need First.....	37
Installing with Windows 95.....	37
Installing with Windows 3.1 or Macintosh .....	39
<b>Configuring with AT Commands .....</b>	<b>40</b>
Overview.....	40
What You Should Know.....	41
<i>Directory Numbers</i> .....	41
<i>Terminal Endpoint Identifier</i> .....	41
Preparing to Send AT Commands .....	41
Configuring and Testing Your I-modem.....	43
<i>Step One: Configuring the I-modem</i> .....	43
<i>Step Two: Checking the Configuration</i> .....	49
<i>Step Three: Saving the Configuration</i> .....	49
<i>Step Four: Testing the Configuration</i> .....	49

<b>The I-modem and ISDN</b> .....	<b>50</b>
What is ISDN? .....	50
Benefits of ISDN .....	50
<i>The ISDN Basic Rate Interface</i> .....	51
<b>Viewing LEDs</b> .....	<b>55</b>
<b>S/T Bus Termination</b> .....	<b>58</b>
<b>The Serial Port</b> .....	<b>60</b>
Choosing a Serial Cable .....	61
Macintosh .....	63
Notices .....	64
<i>European Community</i> .....	64
<b>Limited Warranty</b> .....	<b>66</b>
If You Are Still Having Problems .....	67
<i>For the UK</i> .....	67
<i>For European countries</i> .....	68
<b>Index</b> .....	<b>70</b>

---

## How to Use this Guide

---

Use this Getting Started Guide to obtain the information you need to get your Courier™ I-modem® modem installed, configured, and running correctly.

For more information about advanced commands, see the *Courier I-modem Command Reference*.

---

## Contacting U.S. Robotics

---

Please contact U.S. Robotics if you have any questions.

To do this	Contact
Download updated I-modem code	<a href="http://totalservice.usr.com">http://totalservice.usr.com</a>
Visit the U.S. Robotics web site (U.S.)	<a href="http://www.usr.com">http://www.usr.com</a>
Visit the U.S. Robotics web site (Europe)	<a href="http://europe.usr.com">http://europe.usr.com</a>

Visit the U.S. Robotics web site (France)	<a href="http://www.usr.fr">http://www.usr.fr</a>
Visit the U.S. Robotics web site (Germany)	<a href="http://www.usr.de">http://www.usr.de</a>
Visit the U.S. Robotics web site (Italy)	<a href="http://www.usr.it">http://www.usr.it</a>
Visit the U.S. Robotics web site (U.K.)	<a href="http://www.usr.co.uk">http://www.usr.co.uk</a>
Visit U.S. Robotics on CompuServe	GO USROBOTICS
Visit U.S. Robotics on America Online	Keyword: USROBOTICS

---

## Features

---

For a list of features, see the *Courier I-modem Command Reference*.

---

## I-modem and ISDN

---

The I-modem with ISDN/V.Everything is an Integrated Services Digital Network (ISDN) terminal adapter that can perform all the functions of a Courier V.Everything fax/modem.

The I-modem is capable of exchanging data over the ISDN at speeds of up to 128 kbps with ISDN devices or up to 56 kbps with analogue devices, before compression.

For more information about ISDN, see Appendix A, *The I-modem and ISDN*.

---

## Different I-modem S/T Versions

---

There are two versions of the S/T I-modem:

- The internal PC card with an Analogue Device Port
- The external with an Analogue Device Port (for all platforms that support an EIA-232 interface)

---

## How Does the I-modem Fit In?

---

Once you've subscribed to ISDN service, your ISDN service provider will install a BRI line at your site.

Figure.1 illustrates how the I-modem S/T connects your computer to the ISDN.

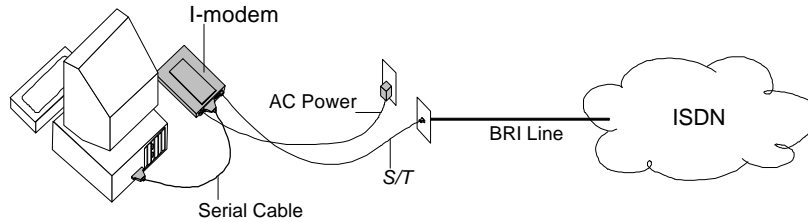

**Figure 1 A Typical Installation of the I-modem S/T.**

# Installing the Internal I-modem

This chapter explains how to:

- Configure COM port and IRQ settings with jumpers
- Configure S/T termination settings with jumpers
- Configure with DIP switches
- Insert the internal I-modem in your PC
- Connect cables to the internal I-modem

---

## Requirements

---

You need the following to install your I-modem:

- IBM-compatible computer with a free interface card slot
- An ISDN Basic Rate Interface line
- A screwdriver

---

## Package Contents

---

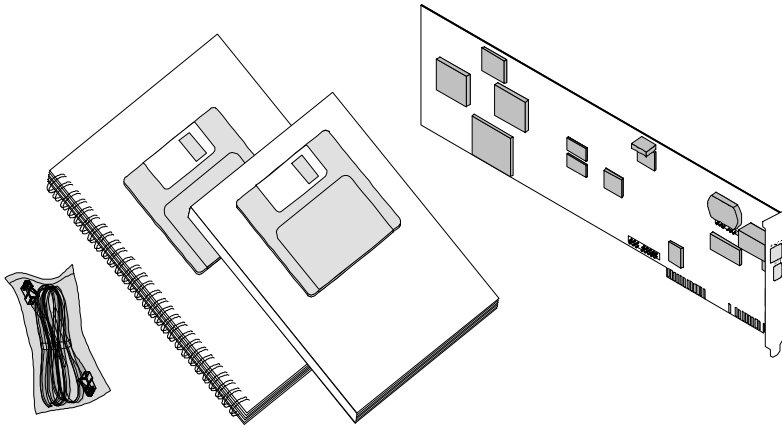

Your I-modem package contains the following items:

- The I-modem
- Telephone cable
- Quick Reference card
- Customer Support card
- This *Getting Started* manual
- I-modem *Configuration Manager* diskette(s).
- I-modem *Command Reference Guide*

**Note:** Your I-modem may contain different items. Each country has different requirements.

---

## Important!

---

The I-modem emulates a *serial interface card* with a 16550 UART. Like serial interface cards, it must be assigned a unique communications (**COM**) port number and a unique interrupt request (**IRQ**) number.

If you are using a computer with a Plug and Play compliant BIOS and operating system and you set the I-modem's jumpers to Plug and Play (the default), your computer's operating system will take care of the COM and IRQ settings for you.

Setting the COM port and IRQ yourself requires a detailed knowledge of the settings of the other adapter cards in your computer. If other adapter cards are set to use the same COM port or IRQ, conflicts may occur that could result in data loss or lockups.

First, determine whether your computer has a Plug and Play ISA bus. Check your computer's documentation to be sure. Keep these points about Plug and Play in mind:

- Your computer's Basic Input/Output System (BIOS) must support Plug and Play.
- Your computer's operating system must support Plug and Play (examples of those that do: OS/2 Warp, Windows 95, Windows NT), or your computer's manufacturer must supply you with Plug and Play software.

---

## Installing Your Internal I-modem

---

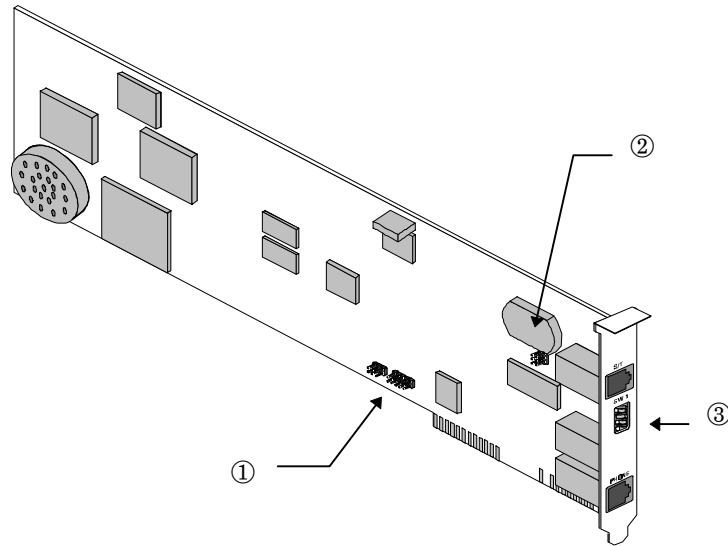

① COM port and IRQ jumpers

② S/T termination jumpers

③ DIP switches

**Figure 2. DIP Switch and Jumper Locations**

To install your internal I-modem, do the following:

**Step One:** Configure your COM port and IRQ settings (if necessary)

**Step Two:** Configure S/T termination settings with jumpers (if necessary)

**Step Three:** Configure your I-modem with DIP switches (if necessary)

**Step Four:** Insert your I-modem

**Step Five:** Connect the cables

---

## Step One: Configure your COM port and IRQ settings

---

You can configure your I-modem's COM port and IRQ settings with two banks of jumpers, which are located near the bottom of the card.

By default, your internal I-modem is set to Plug and Play. You shouldn't have to change this setting, however, if you have multiple devices connected to your system, you may need to change the jumper settings to avoid hardware conflicts.

### Default COM/IRQ Jumper Settings

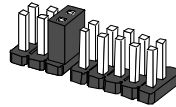

**Figure 3 Default COM/IRQ Jumper Settings**

In addition to the shunt shown in Figure 5, the I-modem is shipped with two additional shunts. These shunts do not affect the configuration of your I-modem because they are attached to only one post; change the positions of these shunts only if you need to change hardware settings.

## Using COM Ports with Different Operating Systems

### Windows 95 Users

If you are using Window 95, you should not need to change the Plug and Play jumper settings, because Windows 95 automatically detects and configures your Courier.

### Other IBM-PC Compatible Operating Systems

If you are using an IBM-PC compatible operating system, you may need to change the jumper settings to a COM port or IRQ setting that is not already used by your system.

### Changing Jumper Settings

You can add shunts to cover sets of pins on the jumper.

**Caution:** If you do not have any hardware conflicts, you do not need to use this section. Go to *Step Two: Configure S/T Termination Settings with Jumpers.*

To change jumper settings, use tweezers or needle-nosed pliers and gently rock the shunt back and forth as you lift.

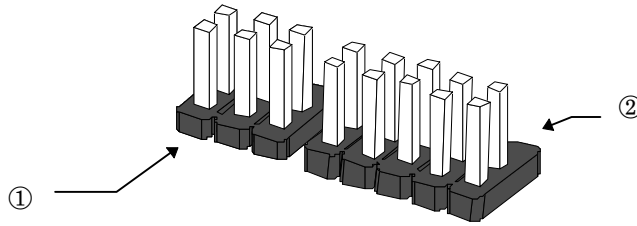

① COM port jumper block (J29)

② IRQ jumper block (J28)

**Figure 4** COM port and IRQ Jumper Blocks Without Shunts

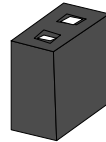





**Figure 5** Shunt

**Note:** Do not grasp the shunts too firmly. If you grasp them too firmly, you may crush the shunt or damage the modem.



## Setting Jumpers for a Specific COM Port

You can put shunts on the COM port (J29) jumper block to configure the desired COM port setting:

To set your modem to	To set the jumpers to
COM 1	
COM 2	
COM 3	
COM 4	
Plug and Play (Default)	

## Setting Jumpers for a Specific IRQ

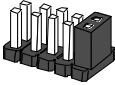
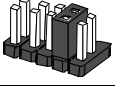
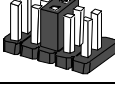
You can put shunts on the IRQ jumper block (J28) to configure the desired IRQ setting:

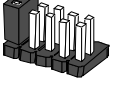
To set your modem to	To set the jumpers to
IRQ 2	
IRQ 3	
IRQ 4	
IRQ 5	
IRQ 7	
Plug and Play	N/A

---

## Step Two: Configure S/T Termination Settings with Jumpers

---

If you are using multiple ISDN devices, you may need to configure your I-modem's S/T termination settings. The default S/T termination settings vary in each country.

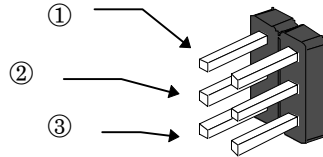

① Pin 1

② Pin 2

③ Pin 3

**Figure 6 S/T Termination Jumper Block Without Shunts**

If you are using your I-modem without any other ISDN devices, set no termination.

**Note:** See *Appendix C, S/T Bus Termination*, for more details about S/T bus termination settings.

## Default S/T Termination Jumper Settings

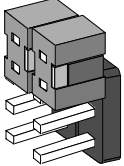
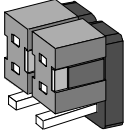
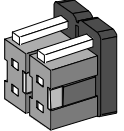
To set your modem to	Set the jumpers to	
No termination	One pin only	
50 ohms	pins 2 and 3	
100 ohms	pins 1 and 2	

---

## Step Three: Configuring with DIP Switches

---

You will probably not need to change the DIP switch settings, but review this section to be sure.

The DIP (Dual Inline Package) switches are located on the bracket of the I-modem.

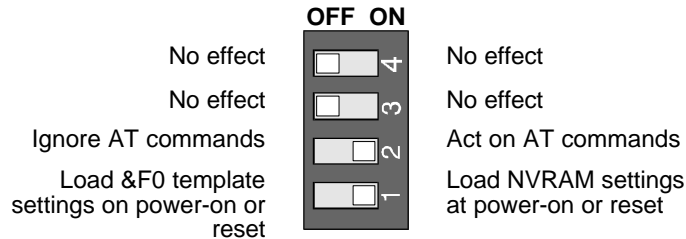

**Figure 7 How to Set the DIP Switches.**

For information about AT commands, refer to Chapter 2, *Using the AT Command Set*, in the *I-modem Command Reference* manual.

This DIP Switch	Position	Does this
1	ON (Default)	Loads the configuration that is stored in non-volatile memory (NVRAM)
	OFF	Loads the &F0 configuration that is stored in read-only memory (ROM)
2	ON (Default)	Acts on AT commands (smart mode)
	OFF	Ignores AT commands (dumb mode)
3	OFF	No effect
4	OFF	No effect

When you power on your computer or reset the I-modem, the DIP switch settings override the settings you may have made previously using AT commands.

**Note:** The following AT commands are not changed by a power-on, reset, or factory defaults (&F) and must be changed manually: **&Cn**, **&Dn**, **En**, **Qn**, **Vn**, **S0**, **S14**, and **S67**, **S68**, **S79**, **S80**, **S81**, and **S82**.

If you change the DIP switch settings while the I-modem is on, you can avoid powering your computer off to make the new settings take effect. Just send the I-modem the ATZ or the ATZ! command. (ATZ! is a “hard” reset, which is just like powering the I-modem off and then on. ATZ is a “soft” reset, which is like rebooting the I-modem and not removing power.)

---

## Step Four: Inserting the Modem

---

**Note:** The illustrations in this section may not match the appearance of your computer. For more detail, refer to your computer's user's manual.

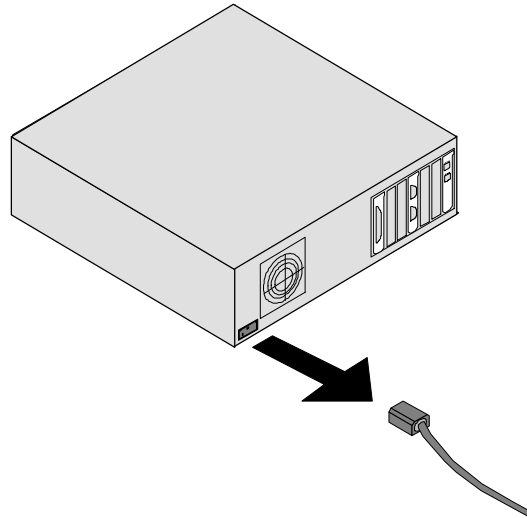

- 1 Turn off the computer's power and unplug the computer's power cord. Ground yourself.

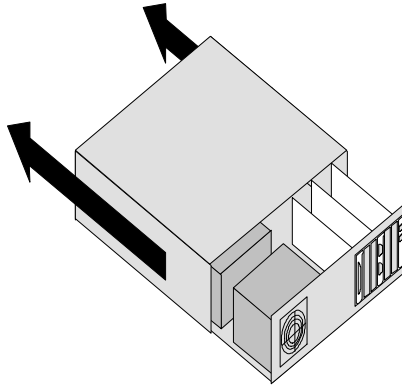

- 2** Remove the screws that hold on the computer's cover and slide the cover off.
- 3** Find an empty expansion slot that provides enough room to install your Courier.
- 4** Remove the screw that holds on the slot cover and remove the slot cover. Save the screw!

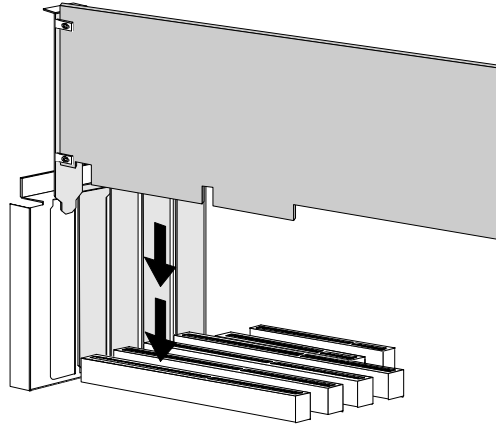

- 5** Insert your Courier into the slot and press down on the top edge of your Courier until it is seated firmly.
- 6** Using the screw you saved in Step 4, secure your Courier in your computer.
- 7** Replace the cover of your computer and tighten the screws.

You are now ready to connect the cables.

---

## Step Five: Connecting the Cables

---

Connect one end of the S/T-interface cable to an S/T interface and the other end to the I-modem.

**Note:** You may also connect an analogue device, such as an analogue telephone, fax machine, or modem to the Analogue Device Port.

You are now ready to test the connection between your I-modem and your computer.

# Installing the External I-modem

This chapter explains how to:

- Connect the serial cable
- Configure S/T termination settings with DIP switches (if necessary)
- Connect the ISDN cable
- Connect the power cord

---

## What You Need

---

You need the following to install your Courier I-modem:

- Computer or terminal with a serial port (16650 UART recommended)
- ISDN Basic Rate Interface (BRI) line

---

## Package Contents

---

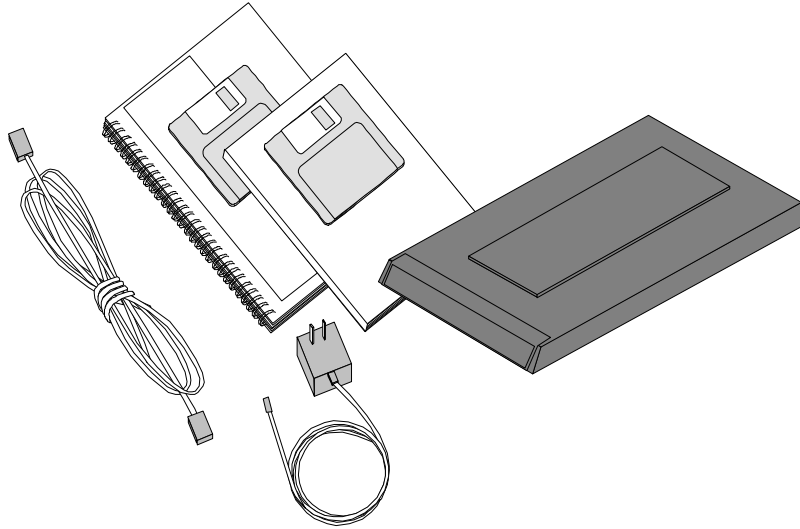

Your Courier I-modem package contains the following items:

- Courier I-modem
- Power adapter
- Telephone cable
- Quick Reference card

- Customer Support card
- This *Getting Started* manual
- I-modem *Configuration Manager* diskette.
- Courier I-modem *Command Reference Guide*

These figures show the controls, displays, and connectors on your Courier I-modem.

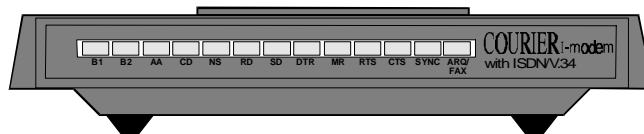

**Figure 8 Front panel of the I-modem**

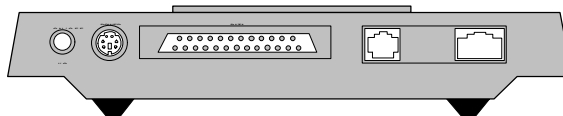

**Figure 9 Rear panel of the I-modem**

---

## Installing Your External I-modem

---

To install your external I-modem, do the following:

**Step One:** Connect the serial cable

**Step Two:** Configure your I-modem with DIP switches (if necessary)





**Step Three:** Configure S/T termination settings (if necessary)

**Step Four:** Connect the ISDN cable

**Step Five:** Connect the power cable

### Step One: Connecting the Serial Cable

Look at the back of your computer for a port:

If you have	Ports may be labeled this way
An IBM-compatible PC	COM, RS-232, or with symbols such as IOIOI,  , or  .
A Macintosh	 (modem port) or  (printer port)

Refer to your computer's documentation to determine the location of the serial port.

## Step Two: Configure S/T Termination Settings

Use the following chart to set termination on the Model S/T.

To set this termination	Set these DIP switches
No termination	9 through 12 OFF
50 Ohm termination	9 and 11 OFF
	10 and 12 ON
100 Ohm termination	9 and 11 ON
	10 and 12 OFF

### Step Three: Configure with DIP Switches

On the external I-modem, the DIP switches are on the bottom of the unit.

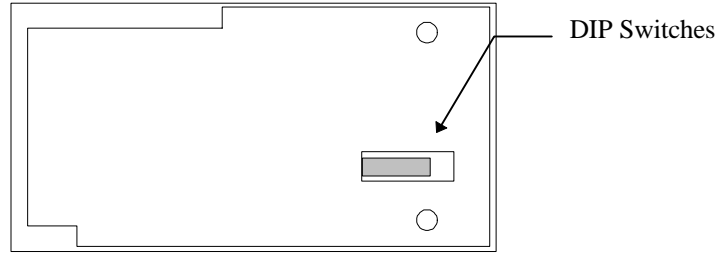



**Figure 10** *DIP Switches on the External Courier*



These are the default settings for the I-modem:

To do this	Set DIP Switch(es)
Load NVRAM settings upon reset	1 ON (Default)
Load &FO settings upon reset	1 OFF
Enable AT commands	2 ON (Default)
Ignore AT commands	2 OFF
Set 0 Ohm termination	9 through 12 OFF
Set 50 Ohm termination	9 and 11 OFF
	10 and 12 ON
Set 100 Ohm termination	9 and 11 ON
	10 and 12 OFF

**Note:** DIP switches 3 - 8 are not used.

## Step Four: Connecting the ISDN Cable

- 1 If you have an IBM-compatible PC, connect the male DB-25 to your Courier I-modem and the other end to COM, RS-232, or with symbols such as **IOIOI**, , or .

If you have a Macintosh, connect the male DB-25 to your Courier I-modem and the other end to  (modem port) or  (printer port)

**Note:** Write down the number of the serial port to which you connect your Courier I-modem. If your serial ports are lettered instead of numbered, A is COM1 and B is COM2. If you cannot find a serial port, consult the documentation that came with your computer.

- 2 Connect one end of the phone cable to the wall jack and the other end to your Courier I-modem port labeled S/T.
- 3 If you have a telephone that you'd like to connect to your Courier I-modem, plug its cable into your Courier port labeled PHONE.

## Step Five: Connect the Power Cable

- 1 Plug one end of the power adapter into your Courier I-modem and the other end to a standard AC power outlet.
- 2 Switch your modem power on. Watch the LED indicators at the front. If there are no problems, the following LEDs should light up.

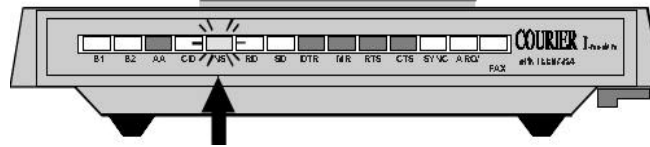

**Note:** Until the Courier makes a call, the NS will blink.

- 3 Switch your computer power on.

You are now ready to test the connection between your I-modem and your computer.

## Testing the Connection between the Computer and I-modem

To test your Courier, use any communications software package, such as Windows Terminal, HyperTerminal, Procomm Plus, or RapidComm. HyperTerminal is used as an example. Every communications program is different; consult the documentation that came with your communications program for more information.

**Note:** If you use Windows 95, see *the Courier I-modem Command Reference*.

- 1** Run HyperTerminal.
- 2** Enter the name of your connection in **Name** and click **OK**.

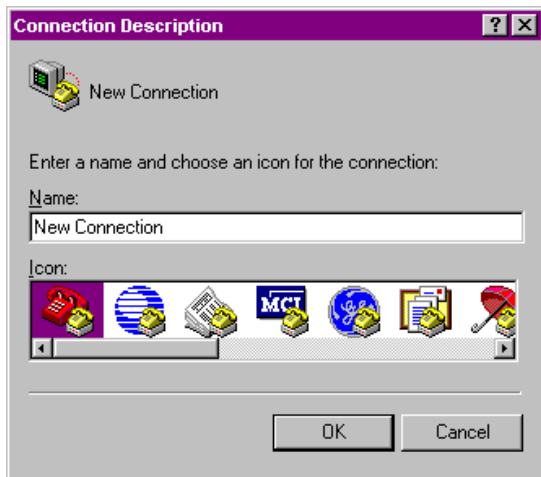

- 3 Enter the phone number you want to dial in **Phone number** and click **OK**. If you only want to test your modem, you may enter any number.

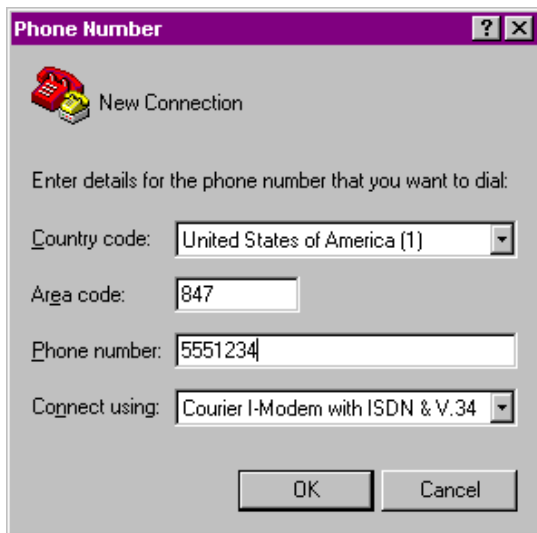

**4** Change any properties and perform the following actions:

To do this	Click this button
Dial a number	<b>Dial</b>
Test without dialing a number	<b>Cancel</b>

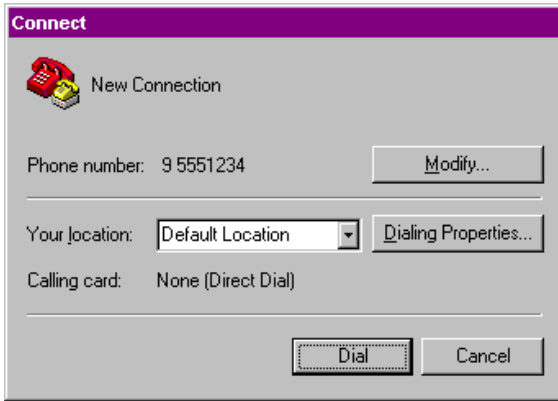

- 5 When the HyperTerminal terminal window appears, enter **AT** and hit **<enter>**. If your modem is connected and configured properly, you will see "OK" on the terminal screen.



You are now ready to configure your I-modem.

# Installing the Configuration Manager

This chapter explains how to install and test the I-modem using the *Configuration Manager*. You can use the *Configuration Manager* if you have Windows 3.x, Windows 95, Windows NT, or Apple Macintosh.

If you prefer to use AT commands to configure your I-modem, see Chapter 6, *Configuring with AT Commands*.

---

## What You Need First

---

Before you can install the I-modem *Configuration Manager*, perform the following actions:

- Obtain your ISDN phone numbers and central-office switch type from your ISDN provider.
- Install and power-on your I-modem

---

## Installing with Windows 95

---

- 1 Install the *Configuration Manager* by running the Setup program on the *Configuration Manager* disk.
- 2 Select the desired language and click **Next**.

- 3** After the *Configuration Manager* detects your I-modem, select the I-modem you want to configure.
- 4** Begin the configuration by clicking on **Basic** or **Expert**.
- 5** Follow the prompts to configure the I-modem.
- 6** If you are using the Expert installation, when you are done configuring your I-modem, select the **Line Test tab** and click on **Test**.

---

## Installing with Windows 3.1 or Macintosh

---

- 1** Install the *Configuration Manager* by running the Setup program on the *Configuration Manager* disk.
- 2** After the *Configuration Manager* detects your I-modem, select the I-modem you want to configure.
- 3** Follow the prompts to configure the I-modem.
- 4** If you are using the Expert installation, when you are done configuring your I-modem, select the **Line Test tab** and click on **Test**.

# Configuring with AT Commands

This chapter explains how to configure and test the I-modem using AT commands and terminal software.

The I-modem Configuration Manager, included with your I-modem, allows you to configure your I-modem without using AT commands.

If you have a Windows 3.x, Windows 95, Windows NT, or Apple Macintosh, you can use the Configuration Manager.

---

## Overview

---

Before you can make any calls, you need to configure the I-modem to work on your ISDN line.

Run your communications software in Terminal Mode and then use your software to send the I-modem AT commands.

---

## What You Should Know

---

### Directory Numbers

Directory Numbers (DNs) take the form of ordinary telephone numbers.

### Terminal Endpoint Identifier

The TEI is a one or two digit number that permanently identifies your connection with the central office switch.

---

## Preparing to Send AT Commands

---

- 1** Get the information from your ISDN service provider that contains your ISDN phone numbers and central-office switch type.
- 2** Start your computer and your communications software. Use a terminal emulation software package, such as HyperTerminal.
- 3** Put your communications software into *Terminal mode*.

When your communications software is in Terminal mode, the commands you type go directly through the serial port to the I-modem. Refer to the manual for your communications software to determine how to change to Terminal mode.

- 4 Set your communications software to use the COM port to which the I-modem is connected, as well as 8 data bits, no parity, and 1 stop bit.
- 5 Send the following command (all commands surrounded by angle brackets, like <Enter>, indicate key presses):

**AT <Enter>**

If you installed the I-modem and set your communications software correctly, it sends the following response:

**OK**

**Note:** If you don't get an OK response, refer to Chapter 15, *Troubleshooting*, in the *I-modem Command Reference*.

---

## Configuring and Testing Your I-modem

---

To configure your Courier, you must perform the following steps.

**Step One:** Configure the analogue device and data device ports.

**Step Two:** Check the I-modem's settings

**Step Three:** Save the settings

**Step Four:** Test the I-modem

### Step One: Configuring the I-modem

Use the following steps to set up your switch type, the Data B-Channel, the analogue device B-Channel, and routing destination for modem, fax, and voice calls.

- 1 Look over the information you received from your ISDN service provider to obtain your central-office switch and protocol type.

To set this switch protocol type	Use this command
ETSI NET 3 (Euro-ISDN) or DSS 1	<b>AT*W=4</b>
France VNx	<b>AT*W=6</b>
1TR6	<b>AT*W=5</b>

## 2 Set up the **DATA** B-channel.

- a** Set the Directory Number (DN). The default DN is blank.

The command is `AT*P2=n`

Example: **AT\*P2=5551112**

- b** Set the Terminal Endpoint Identifier (TEI), if you were assigned one. If not, continue with step **c**.

If your TEI	Use this command
Is dynamic	<b>AT*T2=00</b> (Default)
Is fixed	<b>AT*T2=<i>n</i></b> , where <i>n</i> is a number from 1 to 63.

- c** Set the Call Type.

**Note:** The call type you choose will apply to both incoming and outgoing calls.

<b>If you set this call rype</b>	<b>Use this command</b>
Automatic service choice - Universal Connect (Default)	<b>AT*V2=0</b>
Clear-channel synchronous calls only	<b>AT*V2=4</b>
Internet access mode	<b>AT*V2=5</b>
Modem or fax emulation only	<b>AT*V2=3</b>
V.120 rate adaption calls only	<b>AT*V2=1</b>
V.110 rate adaption calls only	<b>AT*V2=2</b>
X.75 rate adaption calls only	<b>AT*V2=6</b>

**Caution:** When the I-modem is set to **\*V2=0**, the telephone service provider in some countries will issue a charge for each attempt to connect even if the connection is not successful.

- d** Select the Auto Detect protocols. You can only select these protocols if \*V2=0.

To select which protocols the I-modem attempts, set the following values in the S79 register:

To attempt	Set S79 to	Example	Default in
X.75, V.120, analogue	0	<b>S79=0</b>	N/A
X.75, V.110, analogue	1	<b>S79=1</b>	Germany, Sweden, Switzerland, and U.K.
X.75, analogue	2	<b>S79=2</b>	N/A
V.120, V.110, analogue	3	<b>S79=3</b>	Australia, France, and Japan
V.120, analogue	4	<b>S79=4</b>	N/A
V.110, V.120, analogue	5	<b>S79=5</b>	N/A
V.110, analogue	6	<b>S79=6</b>	N/A

**Note:** As a result of the **S79** and **S80** register settings, you do not need to use **S67.0** to enable V.110 (instead of V.120) in the auto detect sequence. **S67.0** is **Reserved** in the help screen and is ignored by the I-modem.

**3** Set up the **ANALOGUE DEVICE** B-channel.

- a** Set the Directory Number (DN). The default DN is blank.

The command is `AT*P1=n`

Example: `AT*P1=5551111`

- b** Set the Terminal Endpoint Identifier (TEI), if you were assigned one. If you were not assigned a TEI, continue with step **c**.

The command is `AT*T1=n`

If your TEI	Use this command
Is dynamic	<code>AT*T1=00</code> (Default)
Is fixed	<code>AT*T1=<i>n</i></code> , where <i>n</i> is a number from 1 to 63.

- c** Set the Call Type.

**Note:** The call type that you choose will apply to outgoing calls only.

The command is `AT*V1=n`

To set this call type	Use this command
3.1 kHz audio (for modem, fax, or voice)	<code>AT*V1=0</code>
Speech (default)	<code>AT*V1=1</code>

You are done configuring your I-modem.

- d** Set the volume of the signal coming through the Analogue Device Port. The default is six or four. The setting `AT*C6` optimises the I-modem for sending and receiving data and fax transmissions.

The command is `AT*Cn`

To set the analogue signal volume	Use this command
Quietest	<code>AT*C0</code>
Loudest	<code>AT*C9</code>

- e** If you have an internal I-modem, set the volume of the onboard speaker's ring.

The command is `AT*Rn`

To set the ring volume	Use this command
Quietest	<code>AT*R0</code>
Loudest	<code>AT*R9</code>

## Step Two: Checking the Configuration

Send **ATI12 <Enter>**, and check that the settings you made are correct.

## Step Three: Saving the Configuration

- 1 Save the new settings by sending **AT&W**.
- 2 Reset the I-modem by sending **ATZ! <Enter>** or power off the modem and power it on again.

**Sending ATZ is not sufficient!** Send **ATZ! <Enter>** Your settings will not take effect until the I-modem undergoes this type of reset.

## Step Four: Testing the Configuration

After you reset your I-modem (in Step Three) watch the I-modem's LED status indicators.

**AA**, **DTR**, **MR**, **RTS**, and **CTS** should be lit green, and **NS** should blink yellow rapidly.

---

## What is ISDN?

---

ISDN is an application of digital technology that provides end-to-end digital service over the public communications network. ISDN was designed to integrate the transmissions from a variety of devices, (computers, telephones, and fax machines) into one digital network.

Because ISDN was designed for transmitting digital information, it has many advantages over the analogue telephone network. Digital transmission is more accurate and reliable, and that helps increase transmission speeds to up to 64 kbps per channel. Using Multilink PPP, your I-modem can attain speeds up to 128 kbps using both channels.

---

## Benefits of ISDN

---

The benefits of ISDN include:

- Increased bandwidth
- Fewer errors during data transfer
- Quicker call setups and teardowns.

## The ISDN Basic Rate Interface

### Physical Appearance

The I-modem communicates over an ISDN Basic Rate Interface (BRI) line. You must order a BRI line from your ISDN service provider before you can use your I-modem.

BRI works over the same wiring that is in place for your analogue telephone lines. The difference is in the equipment you attach and the signaling used.

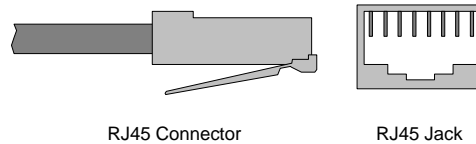

**Figure 11. RJ45 Connector and Jack**

At your site, the BRI line takes the form of an RJ45 wall jack, which is called the *S/T interface*. RJ45 connectors have eight pins.

The telephone company adds a line termination card at their end of the BRI that adapts the line for ISDN. For cable pinout diagrams, refer to Appendix C in the *Courier I-modem Command Reference Manual*.

## B-Channels and D-Channels

Although BRI signals are transmitted over an ordinary pair of wires, BRI typically contains three channels. The channels are created by complex signaling techniques.

BRI is composed of two 64-kbps B-channels and one 16-kbps D-channel:

<b>This</b>	<b>Does this</b>
B-channels	Carries (or "Bears") data or voice traffic
D-channel	Sets up and tears down calls

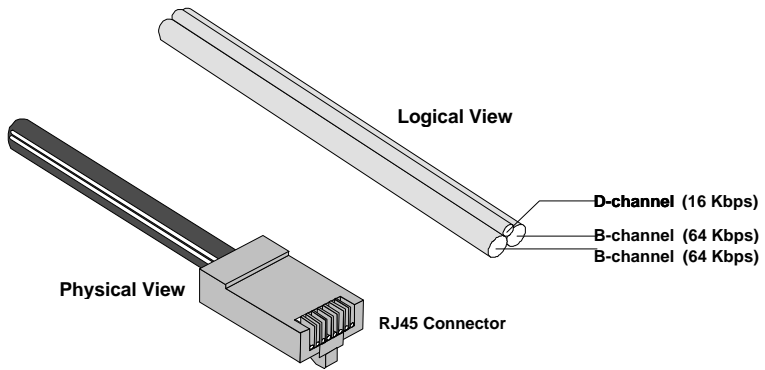
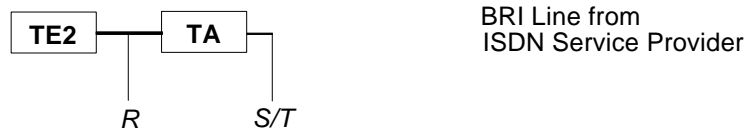

**Figure 12. ISDN BRI**

## Required Components

BRI-line signals must be translated into signals your computer can understand. Several devices must be in place to perform the translation.

This	Is a device
TE2 (Terminal Equipment 2)	Such as your computer or terminal, that does not have built-in ISDN capability. TE2s require Terminal Adapters (TAs), such as the I-modem, to communicate over the ISDN.
TA (Terminal Adapter)	Such as your I-modem, that hat translates between non-ISDN signaling that TE2s provide (such as EIA-232) <i>S/T interface</i> signalling.



**Figure 13. Required Components for ISDN Communications**

## Viewing LEDs

This chapter explains how to view the twelve LEDs on the front of your external I-modem.

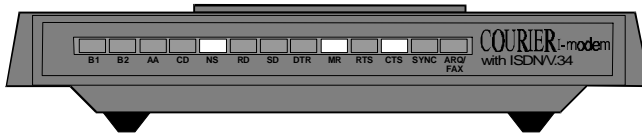

This LED	Status	Means your I-modem
B1	Green blink (8/sec)	Digital call connected at 64 or 56 kbps.
	Green blink (1/sec)	Analog modem or fax call connected.
	Green	Voice call connected.
	Off	Not connected.
B2	Green blink (8/sec)	Digital call connected at 64 or 56 kbps.
	Green blink (1/sec)	Analog modem or fax call connected.
	Off	Not connected.
AA	On	Will auto answer calls
	Blinking	Has detected an incoming call

This LED	Status	Means your I-modem
	Off	Will not auto answer calls
CD	On	Has detected a carrier from a remote device or carrier-detect has been forced on
	Off	Has not detected a carrier
NS	Green Solid	Connect
	Green blink (1/sec)	Physical layer active
	Amber blink (1/sec)	No connection to ISDN or physical interface is inactive
RD	Flashing	Is sending data to your computer
	Off	Is idle
SD	Flashing	Is receiving data from your computer
	Off	Is idle
DTR	On	Has received a Data Terminal Ready (DTR) signal from your computer
	Off	Has not detected DTR
MR	On	Configurable. See <i>Command Reference Manual</i>
	Flashing	Is retraining with a remote device or is in Test mode
	Off	Configurable. See <i>Command Reference Manual</i>

<b>This LED</b>	<b>Status</b>	<b>Means your I-modem</b>
RTS	On	Has detected the Request to Send (RTS) signal from your computer
	Off	Has not detected the RTS signal from your computer
CTS	On	Is sending your computer the Clear to Send (CTS)
	Off	Is not sending your computer the CTS signal
SYNC	On	Is in synchronous mode
	Blinking	Has activated Dial Security
	Off	Is not in synchronous mode/Dial Security not active
ARQ/FAX	On	Is using V.42 <i>bis</i> error correction
	Flashing	Is retransmitting data to the remote modem
	Blinking	Is in fax mode
	Off	Is not using error control, not retransmitting data, and not faxing

## S/T Bus Termination

I-modem S/Ts connect to the ISDN S/T bus. Buses always have two endpoints; in the case of the S/T bus, one end is typically at the ISDN BRI jack and the other is where your last ISDN device connects.

The S/T bus must be terminated properly. To terminate the S/T bus, add a resistor in two places: at the ISDN BRI jack and at the end of the S/T bus .

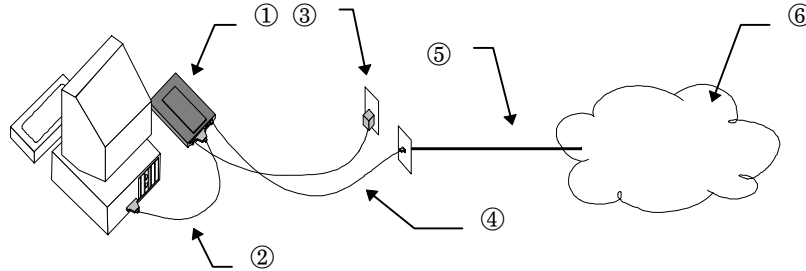

**Figure 14. Sample Point to Point Installation**

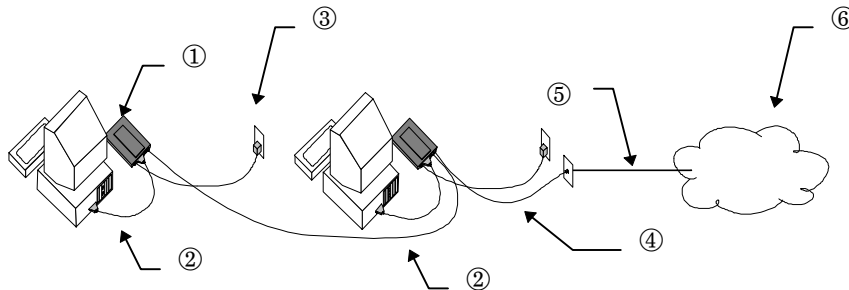

**Figure 15. Sample Multipoint Installation**

- |                             |            |
|-----------------------------|------------|
| ① I-modem (set to 100 ohms) | ④ S/T      |
| ② Serial cable              | ⑤ BRI line |
| ③ AC power                  | ⑥ ISDN     |

## The Serial Port

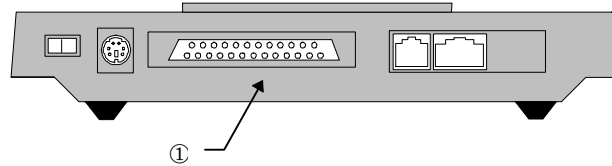

① Serial port

**Figure 16. Location of the Serial Port.**

---

## Choosing a Serial Cable

---

Obtain a serial cable. Use the chart below to determine what type of cable to purchase:

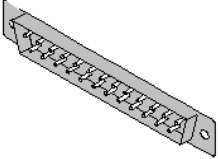
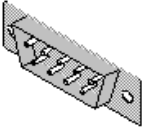
<b>If you have a serial connector in the back of your computer that looks like this</b>	<b>You need to purchase this type of shielded serial connector</b>
	DB-25 female connector to DB-25 female connector
	DB-25 female connector to DB-9 female connector
	8 pin DIN connector for Macintosh

## Notes for Macintosh Users

For top performance, your serial port should support speeds of 115.2 kbps. Most Macintosh serial ports support 57.6 kbps. To make your serial port operate faster, you may need to install a high-speed serial card designed for the Macintosh, such as a NuBus card.

## Notes for Mainframe Users

If you plan to connect your Courier I-modem to a mainframe computer or use your Courier to dial in to a mainframe computer, refer to Synchronous Applications in your Courier *I-modem Command Reference* manual.

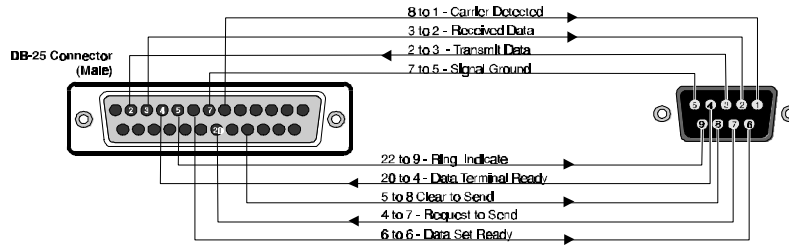

**Figure 17. Pinouts for DB-25 Male Connector.**

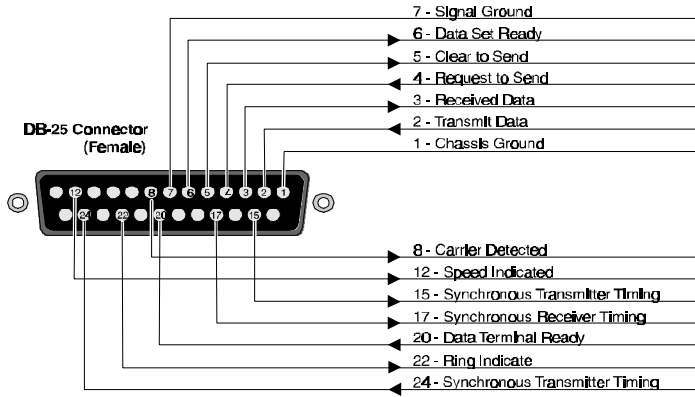

**Figure 18. Pinouts for DB-25 Female Connector.**

---

## Macintosh

---

These are the signals generated or accepted by the I-modem's serial port:

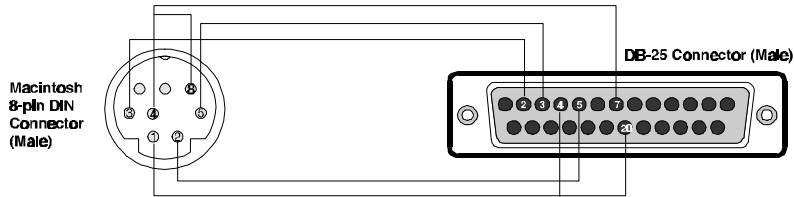

**Figure 19. Pinouts for the Macintosh.**

---

## Notices

---

### European Community

The Courier I-modem with ISDN/V.34 has been approved for connection to the telecommunications network in the European Community under the TTE Directive.

The telecommunications cable supplied with the product is the model used during the approval process. Use of a cable other than the one supplied with the product may affect the performance and violate the approval requirements of the product.

The safety status of the interconnection ports on the Courier I-modem are as follows:

Ports marked as **S/T Interface**= TNV

TNV is a circuit that under normal operating conditions carries Telecommunication Signals

Port marked as **PHONE** = SELV

SELV is a secondary circuit which is so designed and protected that under normal and single fault conditions , the voltage between any two accessible parts does not exceed a safe value (42.4 V peak or 60 V d.c.).

**Important:** You should only connect apparatus complying with the relevant interface requirements to the ports on the Courier I-modem. The analogue interface (PHONE) is intended for connection to standard POTS equipment and not to the analogue telephone network. If you have any doubts seek the advice from an engineer before attaching the apparatus.

## Limited Warranty

U.S. Robotics warrants to the original end-user purchaser that this product will be free from defects in materials and workmanship for a period of five years from the date of purchase. During the limited warranty period, and upon proof of purchase, the product will be repaired or replaced (with the same or a similar model, which may be a refurbished model) at U.S. Robotics' option, without charge for either parts or labour. This limited warranty shall not apply if the product is modified, tampered with, misused, or subjected to abnormal working conditions (including, but not limited to, lightning and water damage).

THIS LIMITED WARRANTY DOES NOT GUARANTEE YOU UNINTERRUPTED SERVICE. REPAIR OR REPLACEMENT AS PROVIDED UNDER THIS LIMITED WARRANTY IS THE EXCLUSIVE REMEDY OF THE PURCHASER. THIS LIMITED WARRANTY IS IN LIEU OF ALL OTHER WARRANTIES, EXPRESS OR IMPLIED, INCLUDING, BUT NOT LIMITED TO, ANY IMPLIED WARRANTY OF MERCHANTABILITY OR FITNESS FOR A PARTICULAR USE OR PURPOSE. U.S. ROBOTICS SHALL IN NO EVENT BE LIABLE FOR ANY SPECIAL, INDIRECT, INCIDENTAL, PUNITIVE OR CONSEQUENTIAL DAMAGES OF ANY KIND OR CHARACTER, INCLUDING, WITHOUT LIMITATION, LOSS OF REVENUE OR PROFITS, FAILURE TO REALIZE SAVINGS OR OTHER BENEFITS, LOSS OF DATA OR USE, DAMAGE TO EQUIPMENT, AND CLAIMS AGAINST THE PURCHASER BY ANY THIRD PERSON, EVEN IF U.S. ROBOTICS HAS BEEN ADVISED OF THE POSSIBILITY OF SUCH DAMAGES.

This limited warranty gives you specific legal rights. You may have others, which vary from nation to nation. Some nations do not allow limitations on duration of an implied warranty, or the exclusion or limitation of incidental or consequential damages, so the above exclusion or limitation may not apply to you.

To obtain service under this limited warranty, contact the U.S. Robotics Technical Support Department .

---

## **If You Are Still Having Problems**

---

### **For the UK**

- Should you encounter any difficulties with your modem, refer to the manual first.
- Call or visit your dealer, if they are unable to assist you, contact the U.S. Robotics Technical Support Department from Monday through to Friday, between 9:30am -5:00pm on.

E-mail address : [uksupport@usr.com](mailto:uksupport@usr.com)

Web site : <http://www.usr.co.uk>

CompuServe : GO UKVENA

BBS : 0118 969 2200

FOD\* : 0118 922 8299

Fax : 0118 969 4222

Tel: 0118 944 1000

\*FOD = Fax on Demand

- Upon contacting U.S. Robotics you will be issued with a Call Reference Number (CRN). This should be quoted when contacting the Technical Support Department in relation to your query.
- Should you be advised to return your modem, U.S. Robotics will repair and return the unit to you.

**Please note that modems can not be returned without prior approval by the U.S. Robotics Technical Support Department.**

## **For European countries**

- Should you encounter any difficulties with your modem, refer to the manual first.
- Call or visit your dealer, if they are unable to assist you, contact the U.S. Robotics Technical Support Department from Monday through to Friday, between 9:30am -5:00pm on.

Hotline: +33 (0) 3 20 19 24 24

Fax: +33 (0) 3 20 19 24 34

USR BBS: +33 (0) 3 20 91 03 08

CompuServe: GO USROBOTICS

Internet: eurosupport@usr.com

- Should you return the modem to us, contact U.S. Robotics Customer Support to obtain a Return Materials Authorisation (RMA) number. You must have an RMA number before returning the modem to us.

Phone : +33 (0) 3 20 87 04 97

Fax : +33 (0) 3 20 87 06 94

- Ship the unit, postage paid, in a strong box made of corrugated cardboard with plenty of packing material (preferably the original container.)
- Include your RMA number, name and address on the shipping label as well as inside the package.
- Ship to the following address:

U.S. Robotics Logistics sarl  
European Repair Center  
RMA#  
Rue Jules Verne  
Centre de Gros N°2  
F-59818 Lesquin Cedex  
France

---

## A

AA LED blinking · 55  
AA LED off · 56  
AA LED on · 55  
advanced commands · 1  
Analog Device Channel  
    call type · 47  
    TEI · 47  
ARQ/FAX LED blinking · 57  
ARQ/FAX LED flashing · 57  
ARQ/FAX LED off · 57  
ARQ/FAX LED on · 57

---

## B

Basic Rate Interface · 51  
BRI · 51  
BRI-line signals · 54

---

## C

cable · 64  
call type  
    Analog Device Channel · 47  
CD LED off · 56; 57  
CD LED on · 56; 57  
central office switch protocol · 43  
COM port  
    requirement · 7  
*Command Reference Guide* · 25  
**Configuring Your Courier I-modem** · 3  
contacting U.S. Robotics · 1  
contents of package · 6; 24

---

## D

Data Channel  
    DN · 44; 47

TEI · 44  
DB-25 · 30; 61  
DB-9 · 61  
default jumper settings · 13  
digital telephone lines · 23  
DN  
    Data Channel · 44; 47

---

## *E*

expansion slot · 20

---

## *F*

fax · 48

---

## *H*

how to use this guide · 1

---

---

## *I*

I-modem and ISDN · 50  
    inserting the modem · 19  
    installation procedure · 30  
    installation, external Courier · 23  
    installing external Courier · 23  
    installing your Courier · 19  
**Installing Your Courier I-modem** · 3  
Integrated Services Digital Network · 3  
Integrated Services Digital Network (ISDN) · 64  
IRQ  
    requirement · 7  
ISDN  
    benefits of · 50  
    defined · 50

---

## *J*

JACK, external modem · 30  
    jumper settings, default · 13

---

## *L*

LEDs · 25; 49

---

---

## *M*

modem port · 26; 30  
MR LED flashing · 56  
MR LED on · 56

---

## *N*

NuBus · 62

---

## *P*

package contents · 6; 24  
PHONE, external modem · 30  
pinouts for serial port · 63  
Plug and Play · 7; 10  
printer port · 26; 30

---

## *R*

RD LED flashing · 56  
RD LED off · 56  
RS LED off · 57  
RS LED on · 57

---

## *S*

S/T Bus Termination · 58  
S/T-interface · 58; 64  
SD LED flashing · 56  
SD LED off · 56  
serial port  
    pinouts for · 63  
    set a specific COM Port · 13  
    set a specific IRQ · 14  
    status indicators · 25; 49  
    switch protocol type · 43  
SYN LED blinking · 57  
SYN LED off · 57  
SYN LED on · 57

---

## *T*

TEI  
    Analog Device Channel · 47  
    Data Channel · 44  
terminal mode · 41  
testing · 49  
testing your Courier · 32  
TR LED off · 56

---

## *U*

U.S. Robotics on Compuserve · 2

U.S. Robotics web site · 1

UART · 7

**Using LEDs, Jumpers, and DIP Switches** · 4

using this guide · 1

---

## *V*

verifying operation · 32

Viewing LEDs · 55

Voice/Data switch · 25

volume control · 25

---

## *W*

Windows 95 · 3



The Intelligent Choice in Information Access

UK :

U.S. Robotics Limited

220 Wharfdale Road

Winnersh

Wokingham

Berkshire

Tel : 0118 922 8200

Fax: 0118 969 5555

Other European countries :

U.S Robotics PCD s.a.r.l

Cityparc, 3 rue Lavoisier

59650 Villeneuve d'Ascq

France

Tel : +33.(0)3.20.19.24.24

Fax : +33.(0)3.20.19.24.34