



RabbitCore RCM3900

C-Programmable Core Module
with *miniSD™* Card Storage and Ethernet

User's Manual

019-0164 • 080528-D

RabbitCore RCM3900 User's Manual

Part Number 019-0164 • 080528–D • Printed in U.S.A.

©2008 Digi International Inc. • All rights reserved.

No part of the contents of this manual may be reproduced or transmitted in any form or by any means without the express written permission of Digi International.

Permission is granted to make one or more copies as long as the copyright page contained therein is included. These copies of the manuals may not be let or sold for any reason without the express written permission of Digi International.

Digi International reserves the right to make changes and improvements to its products without providing notice.

Trademarks

Rabbit and Dynamic C are registered trademarks of Digi International Inc.

Rabbit 3000 and RabbitCore are trademarks of Digi International Inc.

SD and miniSD are trademarks of the SD Card Association.

The latest revision of this manual is available on the Rabbit Web site, www.rabbit.com, for free, unregistered download.

Rabbit Semiconductor Inc.

www.rabbit.com

TABLE OF CONTENTS

Chapter 1. Introduction	1
1.1 RCM3900 Features	2
1.2 Comparing the RCM3365/RCM3375 and the RCM3900/RCM3910	4
1.3 Advantages of the RCM3900	5
1.4 Development and Evaluation Tools.....	6
1.4.1 Development Kit	6
1.4.2 Software	7
1.4.3 Connectivity Interface Kits	7
1.4.4 Online Documentation	7
Chapter 2. Getting Started	9
2.1 Install Dynamic C	9
2.2 Hardware Connections.....	10
2.2.1 Step 1 — Attach Module to Prototyping Board.....	10
2.2.2 Step 2 — Connect Programming Cable.....	11
2.2.3 Connect Power	12
2.3 Starting Dynamic C	13
2.4 Run a Sample Program	13
2.4.1 Troubleshooting	13
2.5 Where Do I Go From Here?	14
2.5.1 Technical Support	14
Chapter 3. Running Sample Programs	15
3.1 Introduction.....	15
3.2 Sample Programs	16
3.2.1 Use of NAND Flash (RCM3900 only)	17
3.2.2 Use of <i>miniSD</i> [™] Cards.....	19
3.2.3 Serial Communication.....	19
3.2.4 Real-Time Clock	21
3.2.5 Other Sample Programs	21
Chapter 4. Hardware Reference	23
4.1 RCM3900 Inputs and Outputs	24
4.1.1 Memory I/O Interface	29
4.1.2 LEDs	29
4.1.3 Other Inputs and Outputs	29
4.2 Serial Communication	30
4.2.1 Serial Ports	30
4.2.2 Ethernet Port	31
4.2.3 Serial Programming Port.....	32
4.3 Serial Programming Cable.....	33
4.3.1 Changing Between Program Mode and Run Mode	33
4.3.2 Standalone Operation of the RCM3900.....	34

4.4	Memory	35
4.4.1	SRAM	35
4.4.2	Flash EPROM	35
4.4.3	NAND Flash (RCM3900 only)	35
4.4.4	miniSD™ Cards	36
4.5	Other Hardware	38
4.5.1	Clock Doubler	38
4.5.2	Spectrum Spreader	38
Chapter 5. Software Reference		39
5.1	More About Dynamic C	39
5.1.1	Developing Programs Remotely with Dynamic C	41
5.2	Dynamic C Functions	42
5.2.1	Digital I/O	42
5.2.2	SRAM Use	42
5.2.3	Serial Communication Drivers	43
5.2.4	TCP/IP Drivers	43
5.2.5	NAND Flash Drivers	43
5.2.6	miniSD™ Card Drivers	44
5.2.7	Prototyping Board Function Calls	45
5.2.7.1	Board Initialization	45
5.2.7.2	Digital I/O	46
5.2.7.3	Switches, LEDs, and Relay	48
5.2.7.4	Serial Communication	51
5.3	Upgrading Dynamic C	52
5.3.1	Extras	52
Chapter 6. Using the TCP/IP Features		53
6.1	TCP/IP Connections	53
6.2	TCP/IP Primer on IP Addresses	55
6.2.1	IP Addresses Explained	57
6.2.2	How IP Addresses are Used	58
6.2.3	Dynamically Assigned Internet Addresses	59
6.3	Placing Your Device on the Network	60
6.4	Running TCP/IP Sample Programs	61
6.4.1	How to Set IP Addresses in the Sample Programs	62
6.4.2	How to Set Up your Computer for Direct Connect	63
6.5	Run the PINGME.C Sample Program	64
6.6	Running Additional Sample Programs With Direct Connect	64
6.6.1	RabbitWeb Sample Programs	65
6.7	Where Do I Go From Here?	66
Appendix A. RCM3900 Specifications		67
A.1	Electrical and Mechanical Characteristics	68
A.1.1	Headers	72
A.2	Bus Loading	73
A.3	Rabbit 3000 DC Characteristics	76
A.4	I/O Buffer Sourcing and Sinking Limit	77
A.5	Conformal Coating	78
A.6	Jumper Configurations	79
Appendix B. Prototyping Board		81
B.1	Introduction	82
B.1.1	Prototyping Board Features	83
B.2	Mechanical Dimensions and Layout	85
B.3	Power Supply	87
B.4	Using the Prototyping Board	88

B.4.1 Adding Other Components.....	89
B.4.2 Digital I/O.....	90
B.4.2.1 Digital Inputs	90
B.4.3 CMOS Digital Outputs.....	91
B.4.4 Sinking Digital Outputs.....	91
B.4.5 Relay Outputs	91
B.4.6 Serial Communication.....	92
B.4.6.1 RS-232.....	93
B.4.6.2 RS-485	94
B.4.7 RabbitNet Port.....	95
B.4.8 Other Prototyping Board Modules	96
B.4.9 Quadrature Decoder	96
B.4.10 Stepper-Motor Control	96
B.5 Prototyping Board Jumper Configurations	98
B.6 Use of Rabbit 3000 Parallel Ports	100
Appendix C. LCD/Keypad Module	103
C.1 Specifications	103
C.2 Contrast Adjustments for All Boards.....	105
C.3 Keypad Labeling	106
C.4 Header Pinouts	107
C.4.1 I/O Address Assignments.....	107
C.5 Mounting LCD/Keypad Module on the Prototyping Board	108
C.6 Bezel-Mount Installation.....	109
C.6.1 Connect the LCD/Keypad Module to Your Prototyping Board.....	111
C.7 Sample Programs	112
C.8 LCD/Keypad Module Function Calls	113
C.8.1 LCD/Keypad Module Initialization.....	113
C.8.2 LEDs.....	114
C.8.3 LCD Display.....	115
C.8.4 Keypad.....	151
Appendix D. Power Supply	159
D.1 Power Supplies.....	159
D.1.1 Battery Backup.....	159
D.1.2 Battery-Backup Circuit	160
D.1.3 Reset Generator	161
Index	163
Schematics	167

1. INTRODUCTION

The RCM3900 RabbitCore modules feature a compact module that incorporates the latest revision of the powerful Rabbit® 3000 micro-processor, flash memory, onboard mass storage (NAND flash), static RAM, digital I/O ports, and removable (“hot-swappable”) memory cards. The RCM3900 RabbitCore modules both have an integrated 10/100Base-T Ethernet port, and provide for LAN and Internet-enabled systems to be built as easily as serial-communication systems.

A Development Kit provides the essentials that you need to design your own microprocessor-based system, and includes a complete Dynamic C software development system. The Development Kit also contains a Prototyping Board that will allow you to evaluate the RCM3900 module and to prototype circuits that interface to the module. You will also be able to write and test software for the RCM3900 modules.

Throughout this manual, the term RCM3900 refers to the complete series of RCM3900 RabbitCore modules unless other production models are referred to specifically.

The RCM3900 has a Rabbit 3000 microprocessor operating at 44.2 MHz, a fast program-execution SRAM, data SRAM, flash memory, two clocks (main oscillator and real-time clock), and the circuitry necessary for reset and management of battery backup of the Rabbit 3000’s internal real-time clock and the data SRAM. Two 34-pin headers bring out the Rabbit 3000 I/O bus lines, parallel ports, and serial ports.

The RCM3900 receives its +3.3 V power from the customer-supplied motherboard on which it is mounted. The RCM3900 can interface with all kinds of CMOS-compatible digital devices through the motherboard.

The RCM3900’s mass-storage capabilities make it suited to running the optional Dynamic C FAT file system module where data are stored and handled using the same directory file structure commonly used on PCs. A removable *miniSD™ Card* can be hot-swapped to transfer data quickly and easily using a standardized file system that can be read away from the RCM3900 installation.

1.1 RCM3900 Features

- Small size: 1.85" x 2.73" x 0.86"
(47 mm x 69 mm x 22 mm)
- Microprocessor: latest revision of Rabbit 3000 running at 44.2 MHz
- 10/100Base-T auto MDI/MDIX Ethernet port chooses Ethernet interface automatically based on whether a crossover cable or a straight-through cable is used in a particular setup
- 52 parallel 5 V tolerant I/O lines: 44 configurable for I/O, 4 fixed inputs, 4 fixed outputs
- Three additional digital inputs, two additional digital outputs
- External reset
- External I/O bus can be configured for 8 data lines and 5 address lines (shared with parallel I/O lines), I/O read/write
- Ten 8-bit timers (six cascadable) and one 10-bit timer with two match registers
- 512K flash memory, 512K program execution SRAM, 512K data SRAM
- Fixed and hot-swappable mass-storage memory options, which may be used with the standardized directory structure supported by the Dynamic C FAT File System module.
- Real-time clock
- Watchdog supervisor
- Provision for customer-supplied backup battery via connections on header J62
- 10-bit free-running PWM counter and four pulse-width registers
- Two-channel Input Capture (shared with parallel I/O ports) can be used to time input signals from various port pins
- Two-channel Quadrature Decoder accepts inputs from external incremental encoder modules
- Five or six 3.3 V CMOS-compatible serial ports with a maximum asynchronous baud rate of 5.525 Mbps. Three ports are configurable as a clocked serial port (SPI), and two ports are configurable as SDLC/HDLC serial ports (shared with parallel I/O ports).
- Supports 1.15 Mbps IrDA transceiver

There are two RCM3900 production models. Table 1 below summarizes their main features.

Table 1. RCM3900 Features

Feature	RCM3900	RCM3910
Microprocessor	Rabbit 3000 running at 44.2 MHz	
SRAM	512K program (fast SRAM) + 512K data	
Flash Memory (program)	512K	
Mass Data Storage	32MB (fixed NAND flash) + 128MB–1GB <i>miniSD™ Card</i>	128MB–1GB <i>miniSD™ Card</i>
Serial Ports	6 shared high-speed, 3.3 V CMOS-compatible ports: <ul style="list-style-type: none"> • all 6 are configurable as asynchronous serial ports; • 4 are configurable as a clocked serial port (SPI) and 1 is configurable as an HDLC serial port; • option for second HDLC serial port at the expense of 2 clocked serial ports (SPI) 	

The RCM3900 is programmed over a standard PC serial port through a USB programming cable supplied with the Development Kit, and can also be programmed directly over an Ethernet link using the Dynamic C download manager with or without a RabbitLink.

Appendix A provides detailed specifications for the RCM3900.

1.2 Comparing the RCM3365/RCM3375 and the RCM3900/RCM3910

- **Temperature Specifications** — We can no longer obtain certain components for the RCM3365/RCM3375 RabbitCore modules that support the -40°C to +70°C temperature range. RCM3365/RCM3375 RabbitCore modules manufactured after May, 2008, are specified to operate at 0°C to +70°C. The RCM3900/RCM3910, rated for -20°C to +85°C, are available after May, 2008.
- **Removable Mass Storage** — The hot-swappable *xD-Picture Card*[™] mass storage device with up to 128MB of memory has been replaced with the *miniSD Card* with up to 1GB of memory. The *miniSD Card* is more readily available today, and is expected to remain readily available for a long time. In addition, *miniSD Cards* provide a significantly larger memory capacity, which has been requested by customers. The trade-off for the larger memory capacity is that the data transfer rate to/from the *miniSD Card* is about an order of magnitude slower than to/from the *xD-Picture Card*.

NOTE: RCM3365/RCM3375 RabbitCore modules may eventually be discontinued because of changes to the *xD-Picture Card*[™].

- **Serial Ports** — Serial Port B, available as either a clocked serial port or an asynchronous serial port on the RCM3365/RCM3375, is used by the RCM3900/RCM3910 as a clocked serial peripheral interface (SPI) for the *miniSD*[™] *Card*, and is not brought out for customer use.
- **General-Purpose I/O** — PD2, a configurable I/O pin on the RCM3365/RCM3375, is used to detect whether the *miniSD*[™] *Card* is installed on the RCM3900/RCM3910, and so PD2 is not brought out for customer use on the RCM3900/RCM3910.
- **Maximum Current** — The RCM3365/RCM3375 draws 250 mA vs. the 325 mA required by the RCM3900/RCM3910.
- **LEDs** — The **SPEED** and user (**USR/BSY**)LED locations have been swapped between the RCM3365/RCM3375 and the RCM3900/RCM3910, the **LNK/ACT** LEDs have been combined to one LED on the RCM3900/RCM3910, and the RCM3900/RCM3910 has an **FDX/COL** LED instead of the **FM** LED on the RCM3365/RCM3375. The LED placements on the boards remain unchanged.
- **Ethernet chip** — A different Ethernet controller chip is used on the RCM3900. The Ethernet chip is able to detect automatically whether a crossover cable or a straight-through cable is being used in a particular setup, and will configure the signals on the Ethernet jack interface.
- **Dynamic C** — As long as no low-level FAT file system calls or direct *xD-Picture Card* access calls to the **NFLASH.LIB** library were used in your application developed for the RCM3365/RCM3375, you may run that application on the RCM3900/RCM3910 after you recompile it using Dynamic C v. 9.62.

NOTE: The Dynamic C RabbitSys option for programming an RCM3365 over an Ethernet link is not supported for the RCM3900.

1.3 Advantages of the RCM3900

- Fast time to market using a fully engineered, “ready-to-run/ready-to-program” micro-processor core.
- Competitive pricing when compared with the alternative of purchasing and assembling individual components.
- Easy C-language program development and debugging
- Program download utility (Rabbit Field Utility) and cloning board options for rapid production loading of programs.
- Generous memory size allows large programs with tens of thousands of lines of code, and substantial data storage.
- Integrated Ethernet port for network connectivity, with royalty-free TCP/IP software.
- Ideal for network-enabling security and access systems, home automation, HVAC systems, and industrial controls.

1.4 Development and Evaluation Tools

1.4.1 Development Kit

The Development Kit contains the hardware and software needed to use the RCM3900.

- RCM3900 module.
- Prototyping Board.
- 512 MB *miniSD*[™] Card with SD Card adapter.
- Universal AC adapter, 12 V DC, 1 A (includes Canada/Japan/U.S., Australia/N.Z., U.K., and European style plugs).
- USB programming cable with 10-pin header.
- *Dynamic C* CD-ROM, with complete product documentation on disk.
- *Getting Started* instructions.
- Accessory parts for use on the Prototyping Board.
- Screwdriver and Cat. 5 Ethernet cables.
- *Rabbit 3000 Processor Easy Reference* poster.
- Registration card.

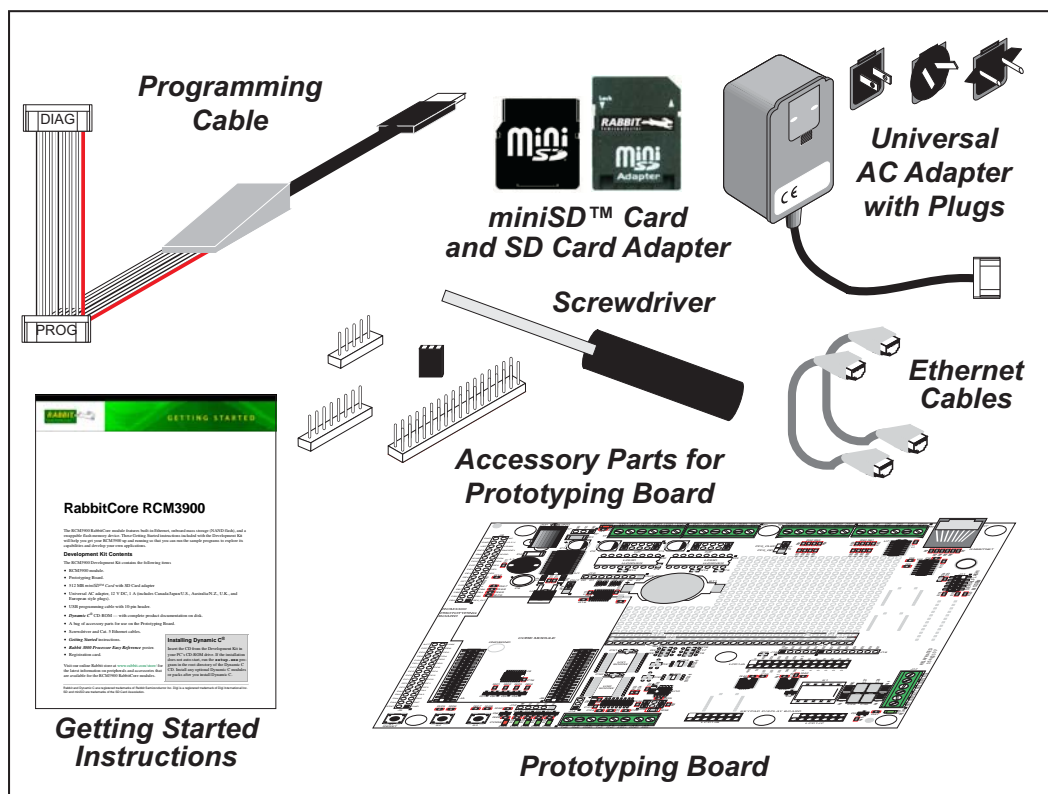

Figure 1. RCM3900 Development Kit

1.4.2 Software

The RCM3900 is programmed using version 9.62 of Dynamic C. A compatible version is included on the Development Kit CD-ROM. This version of Dynamic C includes the popular μ C/OS-II real-time operating system, point-to-point protocol (PPP), FAT file system, RabbitWeb, and other select libraries.

Rabbit also offers for purchase the Rabbit Embedded Security Pack featuring the Secure Sockets Layer (SSL) and a specific Advanced Encryption Standard (AES) library. In addition to the Web-based technical support included at no extra charge, a one-year telephone-based technical support subscription is also available for purchase. Visit our Web site at www.rabbit.com for further information and complete documentation, or contact your Rabbit sales representative or authorized distributor.

1.4.3 Connectivity Interface Kits

Rabbit has available a Connector Adapter Board to allow you to use the RCM3900 with header sockets that have a 0.1" pitch.

- Connector Adapter Board (Part No. 151-0114)—allows you to plug the RCM3900 whose headers have a 2 mm pitch into header sockets with a 0.1" pitch.

Visit our Web site at www.rabbit.com or contact your Rabbit sales representative or authorized distributor for further information.

1.4.4 Online Documentation

The online documentation is installed along with Dynamic C, and an icon for the documentation menu is placed on the workstation's desktop. Double-click this icon to reach the menu. If the icon is missing, use your browser to find and load **default.htm** in the **docs** folder, found in the Dynamic C installation folder.

Each Dynamic C module has complete documentation available with the online documentation described above.

The latest versions of all documents are always available for free, unregistered download from our Web sites as well.

2. GETTING STARTED

This chapter describes the RCM3900 hardware in more detail, and explains how to set up and use the accompanying Prototyping Board.

NOTE: It is assumed that you have the RCM3900 Development Kit. If you purchased an RCM3900 module by itself, you will have to adapt the information in this chapter and elsewhere to your test and development setup.

2.1 Install Dynamic C

To develop and debug programs for the RCM3900 (and for all other Rabbit hardware), you must install and use Dynamic C.

If you have not yet installed Dynamic C, do so now by inserting the Dynamic C CD from the RCM3900 Development Kit in your PC's CD-ROM drive. If autorun is enabled, the CD installation will begin automatically.

If autorun is disabled or the installation otherwise does not start, use the Windows **Start | Run** menu or Windows Explorer to launch `setup.exe` from the root folder of the CD-ROM.

The installation program will guide you through the installation process. Most steps of the process are self-explanatory.

Dynamic C uses a COM (serial) port to communicate with the target development system. The installation allows you to choose the COM port that will be used. The default selection is COM1. Select any available USB port for Dynamic C's use. This selection can be changed later within Dynamic C.

NOTE: The installation utility does not check the selected COM port in any way. Specifying a port in use by another device (mouse, modem, etc.) may lead to a message such as "could not open serial port" when Dynamic C is started.

Once your installation is complete, you will have up to three icons on your PC desktop. One icon is for Dynamic C, one opens the documentation menu, and the third is for the Rabbit Field Utility, a tool used to download precompiled software to a target system.

If you have purchased the optional Dynamic C Rabbit Embedded Security Pack, install it after installing Dynamic C. You must install the Rabbit Embedded Security Pack in the same directory where Dynamic C was installed.

2.2 Hardware Connections

There are three steps to setting up the Prototyping Board:

1. Attach the RCM3900 module to the Prototyping Board.
2. Connect the serial programming cable between the RCM3900 and the workstation PC.
3. Connect the power supply to the Prototyping Board.

2.2.1 Step 1 — Attach Module to Prototyping Board

Turn the RCM3900 module so that the Ethernet jack is facing the direction shown in Figure 2 below. Align the pins from headers J61 and J62 on the bottom side of the module into header sockets JA and JB on the Prototyping Board. The *miniSD™ Card* does not have to be inserted into connector J2 on the RCM3900 at this time—there is a protective spacer insert that you simply pull out before inserting a *miniSD™ Card* for the first time.

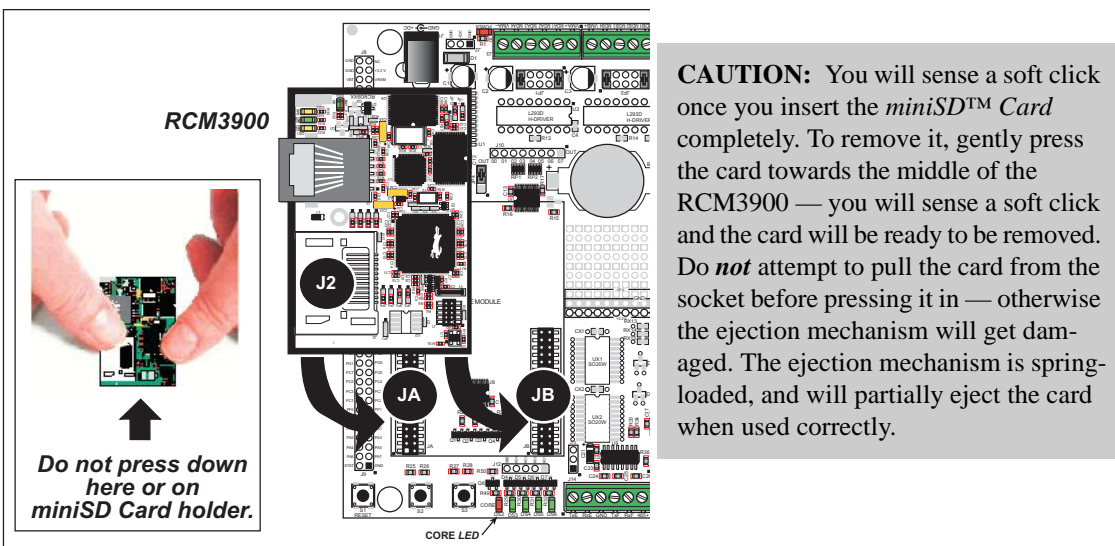

Figure 2. Install the RCM3900 Series on the Prototyping Board

NOTE: It is important that you line up the pins on headers J61 and J62 of the RCM3900 module exactly with the corresponding pins of header sockets JA and JB on the Prototyping Board. The header pins may become bent or damaged if the pin alignment is off-set, and the module will not work. Permanent electrical damage to the module may also result if a misaligned module is powered up.

Press the module's pins firmly into the Prototyping Board header sockets—press down in the area above the header pins using your thumbs or fingers over the header pins as shown in Figure 2. Do not press down on the *miniSD™ Card* connector (J2) even if the *miniSD™ Card* is installed, but rather press down on the circuit board along the edge by the connector. Also, do not press down on the middle of the module to avoid flexing the module, which could damage the module or components on the module.

Should you need to remove the module, grasp it with your fingers along the sides by the connectors and gently work the module up to pull the pins away from the sockets where they are installed. Do not remove the module by grasping it at the top and bottom.

2.2.2 Step 2 — Connect Programming Cable

The programming cable connects the RCM3900 to the PC running Dynamic C to download programs and to monitor the RCM3900 module during debugging.

Connect the 10-pin connector of the programming cable labeled **PROG** to header J1 on the RCM3900 as shown in Figure 3. There is a small dot on the circuit board next to pin 1 of header J1. Be sure to orient the marked (usually red) edge of the cable towards pin 1 of the connector. (Do not use the **DIAG** connector, which is used for a nonprogramming serial connection.)

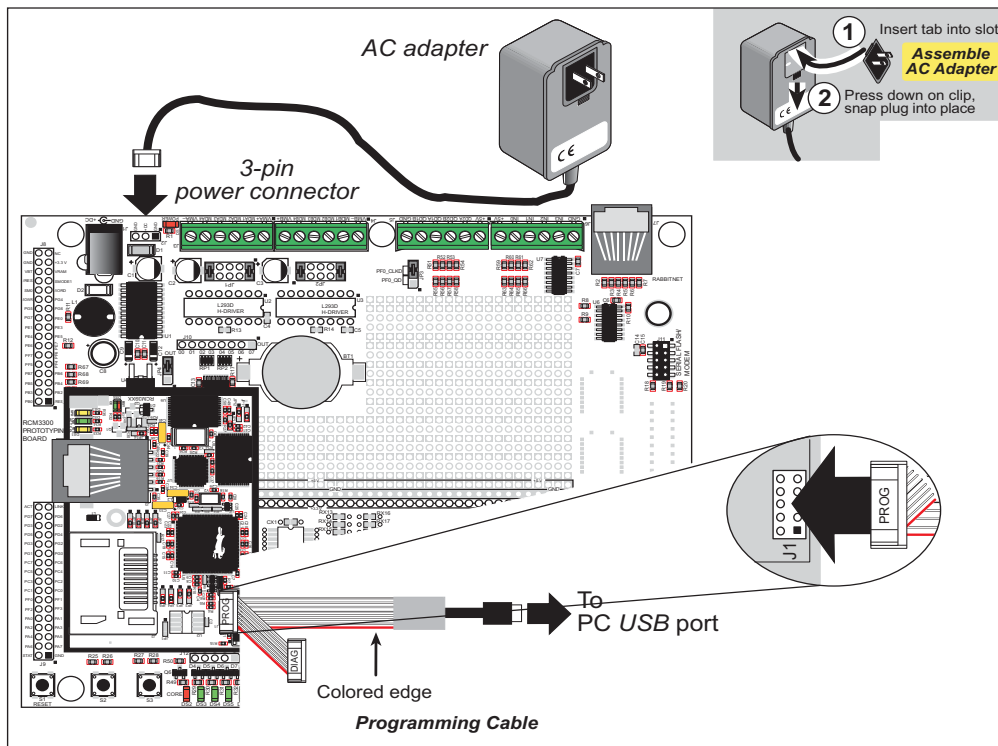

Figure 3. Connect Programming Cable and Power Supply

Connect the other end of the programming cable to an available USB port on your PC or workstation. Your PC should recognize the new USB hardware, and the LEDs in the shrink-wrapped area of the USB programming cable will flash.

2.2.3 Connect Power

When all other connections have been made, you can connect power to the Prototyping Board.

First, prepare the AC adapter for the country where it will be used by selecting the plug. The RCM3900 Development Kit presently includes Canada/Japan/U.S., Australia/N.Z., U.K., and European style plugs. Snap in the top of the plug assembly into the slot at the top of the AC adapter as shown in Figure 3, then press down on the spring-loaded clip below the plug assembly to allow the plug assembly to click into place.

Connect the AC adapter to 3-pin header J2 on the Prototyping Board as shown in Figure 3.

Plug in the AC adapter. The red **CORE** LED on the Prototyping Board should light up. The RCM3900 and the Prototyping Board are now ready to be used.

NOTE: A **RESET** button is provided on the Prototyping Board to allow a hardware reset without disconnecting power.

2.3 Starting Dynamic C

Once the RCM3900 is connected as described in the preceding pages, start Dynamic C by double-clicking on the Dynamic C icon on your desktop or in your **Start** menu. Dynamic C uses the serial port specified during installation. Select **Code and BIOS in Flash, Run in RAM** on the “Compiler” tab in the Dynamic C **Options > Project Options** menu. Then click on the “Communications” tab and verify that **Use USB to Serial Converter** is selected to support the USB programming cable. Click **OK**.

This program shows that the CPU is working. The sample program described in Section 6.5, “Run the PINGME.C Sample Program,” tests the TCP/IP portion of the board.

2.4 Run a Sample Program

Use the **File** menu to open the sample program **PONG.C**, which is in the Dynamic C **SAMPLES** folder. Press function key **F9** to compile and run the program. The **STDIO** window will open on your PC and will display a small square bouncing around in a box.

2.4.1 Troubleshooting

If Dynamic C cannot find the target system (error message "**No Rabbit Processor Detected.**"):

- Check that the RCM3900 is powered correctly — the red **CORE LED** on the Prototyping Board should be lit when the RCM3900 is mounted on the Prototyping Board and the AC adapter is plugged in.
- Check both ends of the programming cable to ensure that they are firmly plugged into the PC and the **PROG** connector, not the **DIAG** connector, is plugged in to the programming port on the RCM3900 with the marked (colored) edge of the programming cable towards pin 1 of the programming header.
- Ensure that the RCM3900 module is firmly and correctly installed in its connectors on the Prototyping Board.
- Select a different COM port within Dynamic C. From the **Options** menu, select **Project Options**, then select another COM port from the list on the **Communications** tab, then click **OK**. Press **<Ctrl-Y>** to force Dynamic C to recompile the BIOS.
- If you get an error message when you plugged the programming cable into a USB port, you will have to install USB drivers. Drivers for Windows XP are available in the Dynamic C **Drivers\Rabbit USB Programming Cable\WinXP_2K** folder — double-click **DPInst.exe** to install the USB drivers. Drivers for other operating systems are available online at www.ftdichip.com/Drivers/VCP.htm.

If Dynamic C appears to compile the BIOS successfully, but you then receive a communication error message when you compile and load a sample program, it is possible that your PC cannot handle the higher program-loading baud rate. Try changing the maximum download rate to a slower baud rate as follows.

- Locate the **Serial Options** dialog on the “Communications” tab in the Dynamic C **Options > Project Options** menu. Select a slower Max download baud rate. Click **OK** to save.

If a program compiles and loads, but then loses target communication before you can begin debugging, it is possible that your PC cannot handle the default debugging baud rate. Try lowering the debugging baud rate as follows.

- Locate the **Serial Options** dialog in the Dynamic C **Options > Project Options > Communications** menu. Choose a lower debug baud rate. Click **OK** to save.

Press **<Ctrl-Y>** to force Dynamic C to recompile the BIOS. The LEDs on the USB programming cable will blink and you should receive a **Bios compiled successfully** message.

2.5 Where Do I Go From Here?

If the sample program ran fine, you are now ready to go on to other sample programs and to develop your own applications. The source code for the sample programs is provided to allow you to modify them for your own use. The *RCM3900 User's Manual* also provides complete hardware reference information and describes the software function calls for the RCM3900, the Prototyping Board, and the optional LCD/keypad module.

For advanced development topics, refer to the *Dynamic C User's Manual* and the *Dynamic C TCP/IP User's Manual*, also in the online documentation set.

2.5.1 Technical Support

NOTE: If you purchased your RCM3900 through a distributor or through a Rabbit partner, contact the distributor or partner first for technical support.

If there are any problems at this point:

- Use the Dynamic C **Help** menu to get further assistance with Dynamic C.
- Check the Rabbit Technical Bulletin Board and forums at www.rabbit.com/support/bb/ and at www.rabbit.com/forums/.
- Use the Technical Support e-mail form at www.rabbit.com/support/.

3. RUNNING SAMPLE PROGRAMS

To develop and debug programs for the RCM3900 (and for all other Rabbit hardware), you must install and use Dynamic C.

3.1 Introduction

To help familiarize you with the RCM3900 modules, Dynamic C includes several sample programs. Loading, executing and studying these programs will give you a solid hands-on overview of the RCM3900's capabilities, as well as a quick start with Dynamic C as an application development tool.

NOTE: The sample programs assume that you have at least an elementary grasp of the C programming language. If you do not, see the introductory pages of the *Dynamic C User's Manual* for a suggested reading list.

In order to run the sample programs discussed in this chapter and elsewhere in this manual,

1. Your RCM3900 must be plugged in to the Prototyping Board as described in Chapter 2, "Getting Started."
2. Dynamic C must be installed and running on your PC.
3. The programming cable must connect the programming header (J1) on the RCM3900 to your PC.
4. Power must be applied to the RCM3900 through the Prototyping Board.

Refer to Chapter 2, "Getting Started," if you need further information on these steps.

Since the RCM3900 runs at 44.2 MHz and is equipped with a fast program execution SRAM, remember to allow the compiler to run the application in the fast program execution SRAM by selecting **Code and BIOS in Flash, Run in RAM** from the Dynamic C **Options > Project Options > Compiler** menu.

To run a sample program, open it with the **File** menu, then compile and run it by pressing **F9**.

Complete information on Dynamic C is provided in the *Dynamic C User's Manual*.

3.2 Sample Programs

Of the many sample programs included with Dynamic C, several are specific to the RCM3900. Sample programs illustrating the general operation of the RCM3900, serial communication, and the NAND flash are provided in the **SAMPLES\RCM3900** folder. Each sample program has comments that describe the purpose and function of the program. Follow the instructions at the beginning of the sample program.

TCP/IP sample programs are described in Chapter 6, “Using the TCP/IP Features.” Sample programs for the optional LCD/keypad module that is used on the RCM3900 Prototyping Board are described in Appendix C.

- **CONTROLLEDS.C**—Demonstrates use of the digital outputs by having you turn the LEDs on the Prototyping Board on or off from the **STDIO** window on your PC.

Once you compile and run **CONTROLLEDS.C**, the following display will appear in the Dynamic C **STDIO** window.

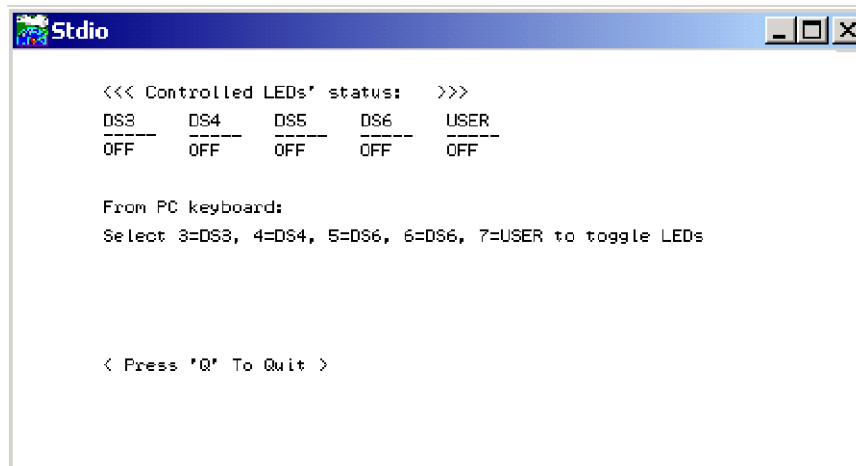

```
Stdio
<<< Controlled LEDs' status: >>>
DS3   DS4   DS5   DS6   USER
---   ---   ---   ---   ---
OFF   OFF   OFF   OFF   OFF

From PC keyboard:
Select 3=DS3, 4=DS4, 5=DS6, 6=DS6, 7=USER to toggle LEDs

< Press 'Q' To Quit >
```

Press “3” or “4” or “5” or “6” or “7” on your keyboard to select LED DS3 or DS4 or DS5 or DS6 on the Prototyping Board or the **USR** LED on the RCM3900. Then follow the prompt in the Dynamic C **STDIO** window to turn the LED on or off.

- **FLASHLEDS.C**—Demonstrates assembly-language program by flashing the **USR** LED on the RCM3900 and LEDs DS3, DS4, DS5, and DS6 on the Prototyping Board.
- **SWRELAY.C**—Demonstrates the relay-switching function call using the relay installed on the Prototyping Board by toggling the relay output state via the Dynamic C **STDIO** window.
- **TOGGLESWITCH.C**—Uses costatements (cooperative multitasking) to detect switches S2 and S3 using debouncing. The corresponding LEDs (DS3 and DS4) will turn on or off.

Once you have loaded and executed these four programs and have an understanding of how Dynamic C and the RCM3900 modules interact, you can move on and try the other sample programs, or begin building your own.

3.2.1 Use of NAND Flash (RCM3900 only)

The following sample programs can be found in the `SAMPLES\RCM3900\NANDFlash` folder.

NOTE: These sample programs cannot be run on the RCM3910, which does not have NAND flash installed.

- **NFLASH_DUMP.C**—This program is a utility for dumping the nonerased contents of a NAND flash chip to the Dynamic C **STDIO** window, and the contents may be redirected to a serial port.

When the sample program starts running, it attempts to communicate with the NAND flash chip. If this communication is successful and the main page size is acceptable, the nonerased page contents (non 0xFF) from the NAND flash page are dumped to the Dynamic C **STDIO** window.

Note that an error message might appear when the first 32 pages (0x20 pages) are “dumped.” You may ignore the error message.

- **NFLASH_ERASE.C**—This program is a utility for erasing all the good blocks of a NAND flash device.

When the sample program starts running, it attempts to initialize the onboard NAND flash chip. If this initialization is successful, the progress of the blocks being erased is reported in the Dynamic C **STDIO** window.

- **NFLASH_INSPECT.C**—This program is a utility for inspecting the contents of a NAND flash chip. When the sample program starts running, it attempts to initialize the onboard NAND flash chip. If this initialization is successful, the user can execute various commands to print out the contents of a specified page, clear (set to zero) all the bytes in a specified page, erase (set to FF), or write a specified value or count pattern to specified pages.

When you run this sample program, setting the **NFLASH_USEERASEBLOCKSIZE** macro to (0) zero makes the NAND flash driver use smaller (512-byte) chunks of data, which are less tedious to manage in this program than the alternative larger (16K) chunks of data. However, using smaller chunks of data means more NAND flash block erases are required to update all the program pages in an erased block, one per program page written. In contrast, updating all the program pages in an erased block can require only a single block erase when all of the program pages within the erase block are treated as a single large page. See the `nf_initDevice()` function help for more information.

- **NFLASH_LOG.C**—This program runs a simple Web server that stores a log of hits in the NAND flash. This log can be viewed and cleared from a Web browser by connecting the RJ-45 jack on the RCM3900 to your PC as described in Section 6.1. The sidebar on the next page explains how to set up your PC or notebook to view this log.

Before you compile and run this sample program, make any configuration changes to match your requirements. Once you are viewing the results in a Web browser, click the [“Source code”](#) link on the Web page to see this sample program’s `#ximported` file content.

Note that this sample program does not use the optimum method of writing to the NAND flash. The inefficiency resulting from the small amount of data written in each append operation is offset somewhat by the expected relative infrequency of these writes, and by the sample program's method of "walking" through the flash blocks when appending data as well as when a log is cleared.

There is little difference in the number of NAND flash block erase operations regardless of whether the `NFLASH_USEERASEBLOCKSIZE` macro is 0 (zero) or 1 (one). It is slightly more efficient to have the NAND flash driver use larger (16K) chunks of data. See the `nf_initDevice()` function help for more information.

Follow these instructions to set up your PC or notebook. Check with your administrator if you are unable to change the settings as described here since you may need administrator privileges. The instructions are specifically for Windows 2000, but the interface is similar for other versions of Windows.

TIP: If you are using a PC that is already on a network, you will disconnect the PC from that network to run these sample programs. Write down the existing settings before changing them to facilitate restoring them when you are finished with the sample programs and reconnect your PC to the network.

1. Go to the control panel (**Start > Settings > Control Panel**), and then double-click the Network icon.
2. Select the network interface card used for the Ethernet interface you intend to use (e.g., **TCP/IP Xircom Credit Card Network Adapter**) and click on the "Properties" button. Depending on which version of Windows your PC is running, you may have to select the "Local Area Connection" first, and then click on the "Properties" button to bring up the Ethernet interface dialog. Then "Configure" your interface card for a "10Base-T Half-Duplex" or an "Auto-Negotiation" connection on the "Advanced" tab.

NOTE: Your network interface card will likely have a different name.

3. Now select the **IP Address** tab, and check **Specify an IP Address**, or select TCP/IP and click on "Properties" to assign an IP address to your computer (this will disable "obtain an IP address automatically"):

IP Address : 10.10.6.101

Netmask : 255.255.255.0

Default gateway : 10.10.6.1

4. Click **<OK>** or **<Close>** to exit the various dialog boxes.

As long as you have not modified the `TCPCONFIG 1` macro in the sample program, enter the following server address in your Web browser to bring up the Web page served by the sample program.

`http://10.10.6.100`

Otherwise use the TCP/IP settings you entered in the `LIB\TCPIP\TCP_CONFIG.LIB` library.

3.2.2 Use of *miniSD*TM Cards

The following sample program can be found in the **SAMPLES\RCM3900\SD_Flash** folder.

- **SDFLASH_INSPECT.C**—This program is a utility for inspecting the contents of a *miniSD*TM Card. When the sample program starts running, it attempts to initialize the *miniSD*TM Card on Serial Port B. The following five commands are displayed in the Dynamic C **STDIO** window if a *miniSD*TM Card is found:

- p — print out the contents of a specified page on the *miniSD*TM Card
- r — print out the contents of a range of pages on the *miniSD*TM Card
- c — clear (set to zero) all of the bytes in a specified page
- f — sets all bytes on the specified page to the given value
- t — write user-specified text to a selected page

The sample program prints out a single line for a page if all bytes in the page are set to the same value. Otherwise it prints a hex/ASCII dump of the page.

This utility works with the *miniSD*TM Card at its lowest level, and writing to pages will likely make the *miniSD*TM Card unreadable by a PC. For PC compatibility, you must use the Dynamic C FAT file system module, which allows you to work with files on the *miniSD*TM Card in a way that they will be PC-compatible.

- **SDFLASH_LOG.C**—This program demonstrates a simple Web server that stores a log of hits in the *miniSD*TM Card's data flash. This log can be viewed and cleared from a Web browser—see the **NFLASH_LOG.C** sample program for information on how to access the Web page and configure your PC or workstation.

3.2.3 Serial Communication

The following sample programs can be found in the **SAMPLES\RCM3900\SERIAL** folder.

- **FLOWCONTROL.C**—This program demonstrates hardware flow control by configuring Serial Port F for CTS/RTS with serial data coming from TxE (Serial Port E) at 115,200 bps. One character at a time is received and is displayed in the **STDIO** window.

To set up the Prototyping Board, you will need to tie TxE and RxE together on the RS-232 header at J14, and you will also tie TxF and RxF together as shown in the diagram.

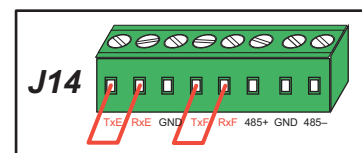

A repeating triangular pattern should print out in the **STDIO** window. The program periodically switches RTS (TxF) flow control on or off to demonstrate the effect of hardware flow control. You may use an oscilloscope to observe the CTS/RTS signals to see flow control operating

- **PARITY.C**—This program demonstrates the use of parity modes by repeatedly sending byte values 0–127 from Serial Port E to Serial Port F. The program will switch between generating parity or not on Serial Port E. Serial Port F will always be checking parity, so parity errors should occur during every other sequence.

To set up the Prototyping Board, you will need to tie TxE and RxF together on the RS-232 header at J14 as shown in the diagram.

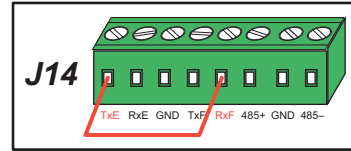

The Dynamic C **STDIO** window will display the error sequence.

- **SIMPLE3WIRE.C**—This program demonstrates basic RS-232 serial communication. Lower case characters are sent by TxE, and are received by RxF. The characters are converted to upper case and are sent out by TxF, are received by RxE, and are displayed in the Dynamic C **STDIO** window.

To set up the Prototyping Board, you will need to tie TxE and RxF together on the RS-232 header at J14, and you will also tie RxE and TxF together as shown in the diagram.

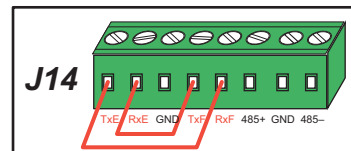

- **SIMPLE5WIRE.C**—This program demonstrates 5-wire RS-232 serial communication by providing flow control (RTS/CTS) on Serial Port F and data flow on Serial Port E.

To set up the Prototyping Board, you will need to tie TxE and RxE together on the RS-232 header at J14, and you will also tie TxF and RxF together as shown in the diagram.

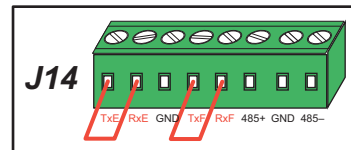

Once you have compiled and run this program, you can test flow control by disconnecting TxF from RxF while the program is running. Characters will no longer appear in the **STDIO** window, and will display again once TxF is connected back to RxF. (Do not disconnect the data path between TxE and RxE.)

- **SWITCHCHAR.C**—This program transmits and then receives an ASCII string on Serial Ports E and F. It also displays the serial data received from both ports in the **STDIO** window.

To set up the Prototyping Board, you will need to tie TxE and RxF together on the RS-232 header at J14, and you will also tie RxE and TxF together as shown in the diagram.

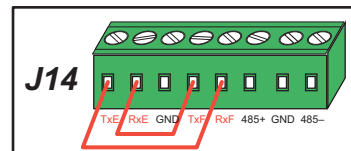

Once you have compiled and run this program, press and release S2 on the Prototyping Board to send a message from Serial Port E to Serial Port F; press and release S3 on the Prototyping Board to send a message from Serial Port F to Serial Port E. The data sent between the serial ports will be displayed in the **STDIO** window.

Two sample programs, **SIMPLE485MASTER.C** and **SIMPLE485SLAVE.C**, are available to illustrate RS-485 master/slave communication. To run these sample programs, you will need a second Rabbit-based system with RS-485—the second system may be another RCM3900, or it may be any Rabbit single-board computer or RabbitCore module that supports RS-485 serial communication as long as you use the master or slave sample program associated with that board.

Before running either of these sample programs on the RCM3900 assembly, make sure pins 1–2 and pins 5–6 are jumpered together on header JP5 to use the RS-485 bias and termination resistors. The sample programs use Serial Port C as the RS-485 serial port, and they use PD7 to enable/disable the RS-485 transmitter.

The RS-485 connections between the slave and master devices are as follows.

- RS485+ to RS485+
- RS485– to RS485–
- GND to GND
- **SIMPLE485MASTER.C**—This program demonstrates a simple RS-485 transmission of lower case letters to a slave. The slave will send back converted upper case letters back to the master and display them in the **STDIO** window. Use **SIMPLE485SLAVE.C** to program the slave—reset the slave before you run **SIMPLE485MASTER.C** on the master.
- **SIMPLE485SLAVE.C**—This program demonstrates a simple RS-485 transmission of lower case letters to a master. The slave will send back converted upper case letters back to the master and display them in the **STDIO** window. Compile and run this program on the slave before you use **SIMPLE485MASTER.C** to program the master.

3.2.4 Real-Time Clock

If you plan to use the real-time clock functionality in your application, you will need to set the real-time clock. Set the real-time clock using the Dynamic C **SAMPLES\RTCLOCK\SETRTCKB.C** sample program by following the onscreen prompts. The Dynamic C **SAMPLES\RTCLOCK\RTC_TEST.C** sample program provides additional examples of how to read and set the real-time clock.

3.2.5 Other Sample Programs

Section 6.6 describes the TCP/IP sample programs, and Appendix C.7 provides sample programs for the optional LCD/keypad module that can be installed on the Prototyping Board.

4. HARDWARE REFERENCE

Chapter 4 describes the hardware components and principal hardware subsystems of the RCM3900 modules. Appendix A, “RCM3900 Specifications,” provides complete physical and electrical specifications.

Figure 4 shows the Rabbit-based subsystems designed into the RCM3900.

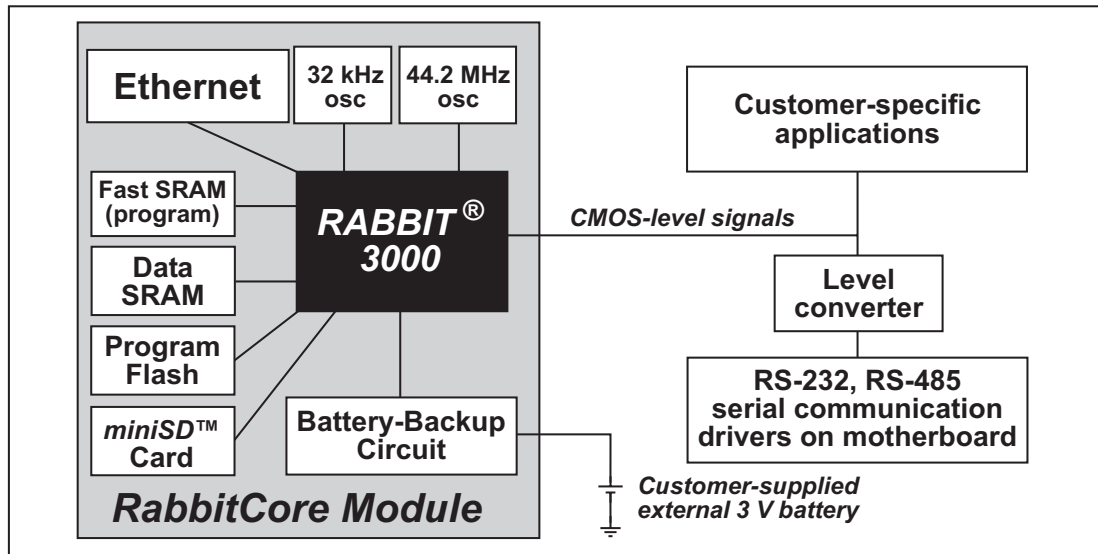

Figure 4. RCM3900 Subsystems

4.1 RCM3900 Inputs and Outputs

Figure 5 shows the RCM3900 pinouts for headers J61 and J62.

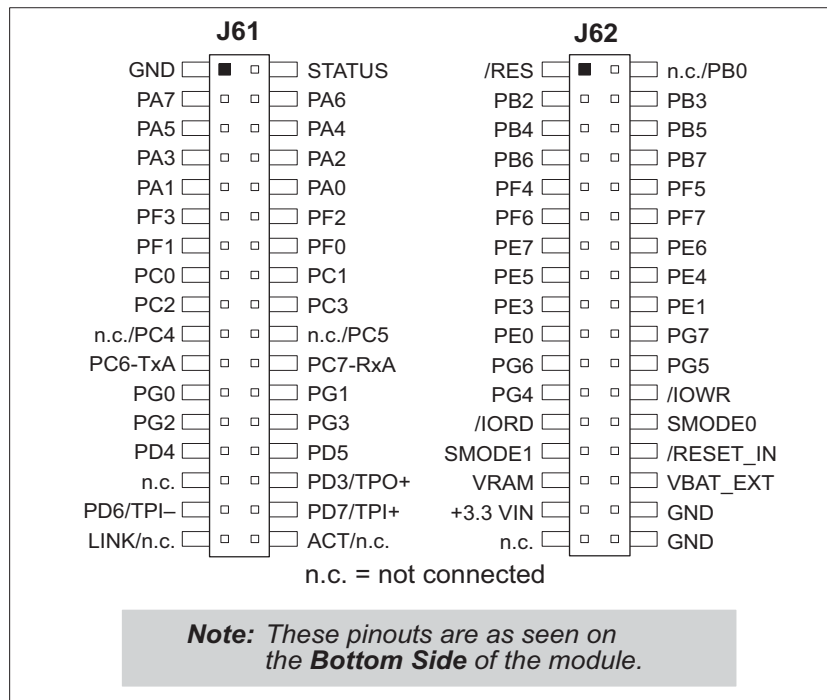

Figure 5. RCM3900 Pinouts

The pinouts for the RCM3000, RCM3100, RCM3200, RCM3300/RCM3305/RCM3309/RCM3319, RCM3360/RCM3370, RCM3365/RCM3375, and RCM3900 are almost compatible, except signals PB0, PC4, and PC5. are used for the SPI interface to the serial flash on the RCM3305/RCM3309/RCM3315/RCM3319 and for the *miniSD™ Card* on the RCM3900/RCM3910, but are available on the other modules.

Headers J61 and J62 are standard 2×17 headers with a nominal 2 mm pitch. An RJ-45 Ethernet port is also included with the RCM3900.

Pins 29–32 on header J61 are configured using 0Ω resistors at locations JP9, JP10, JP7, and JP8 to enable connections to PD2, PD3, PD6, and PD7 respectively. Note that there is no 0Ω resistor at location JP9 since PD2/TPO– is not available on header J61. They may also be reconfigured to carry the Ethernet signals TPO–, TPO+, TPI–, and TPI+, but this capability is reserved for future use.

Pins 33 and 34 on header J61 are wired via 0Ω surface-mount resistors at JP2 and JP3 to carry the **ACT** and **LINK** signals that illuminate the corresponding LEDs on the RCM3900 module. These pins may be “configured” to carry PD0 and PD1, an option that is reserved for future use.

See Appendix A.6 for more information about the locations of these headers.

Figure 6 shows the use of the Rabbit 3000 microprocessor ports in the RCM3900 modules.

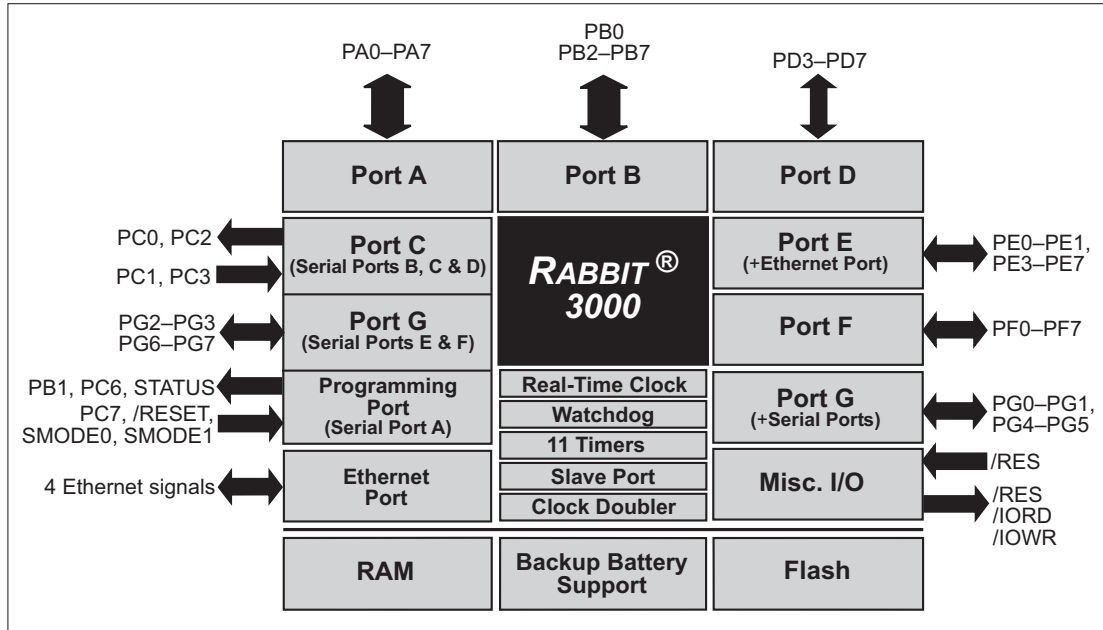

Figure 6. Use of Rabbit 3000 Ports

The ports on the Rabbit 3000 microprocessor used in the RCM3900 are configurable, and so the factory defaults can be reconfigured. Table 2 lists the Rabbit 3000 factory defaults and the alternate configurations.

Table 2. RCM3900 Pinout Configurations

Pin	Pin Name	Default Use	Alternate Use	Notes
1	GND			
2	STATUS	Output (Status)	Output	
3–10	PA[7:0]	Parallel I/O	External data bus (ID0–ID7) Slave port data bus (SD0–SD7)	External Data Bus
11	PF3	Input/Output	QD2A	
12	PF2	Input/Output	QD2B	
13	PF1	Input/Output	QD1A CLKC	
14	PF0	Input/Output	QD1B CLKD	
15	PC0	Output	TXD	Serial Port D
16	PC1	Input	RXD	
17	PC2	Output	TXC	Serial Port C
18	PC3	Input	RXC	
19	PC4	Output	TXB	Serial Port B (used by <i>miniSD™</i> Card SPI)
20	PC5	Input	RXB	
21	PC6	Output	TXA	Serial Port A (programming port)
22	PC7	Input	RXA	
23	PG0	Input/Output	TCLKF	Serial Clock F output
24	PG1	Input/Output	RCLKF	Serial Clock F input
25	PG2	Input/Output	TXF	Serial Port F
26	PG3	Input/Output	RXF	
27	PD4	Input/Output	ATXB	
28	PD5	Input/Output	ARXB	
29	not connected	—	—	Optional Ethernet transmit port
30	PD3/TPO+	Input/Output	TPOUT+ *	
31	PD6/TPI–	Input/Output	TPIN– *	Optional Ethernet receive port
32	PD7/TPI+	Input/Output	TPIN+ *	
33	LINK	Output		Max. sinking current draw 1 mA (see Note 1)
34	ACT	Output		

* Pins 30–32 Ethernet option is reserved for future use.

Table 2. RCM3900 Pinout Configurations (continued)

Pin	Pin Name	Default Use	Alternate Use	Notes	
Header. J62	1	/RES	Reset output	Reset output from Reset Generator	
	2	PB0	Input/Output	CLKB	CLKB (used by <i>miniSD™</i> Card SPI)
	3	PB2	Input/Output	IA0 /SWR	External Address 0 Slave port write
	4	PB3	Input/Output	IA1 /SRD	External Address 1 Slave port read
	5	PB4	Input/Output	IA2 SA0	External Address 2 Slave port Address 0
	6	PB5	Input/Output	IA3 SA1	External Address 3 Slave port Address 1
	7	PB6	Input/Output	IA4	External Address 4
	8	PB7	Input/Output	IA5 /SLAVEATTN	External Address 5 Slave Attention
	9	PF4	Input/Output	AQD1B PWM0	
	10	PF5	Input/Output	AQD1A PWM1	
	11	PF6	Input/Output	AQD2B PWM2	
	12	PF7	Input/Output	AQD2A PWM3	
	13	PE7	Input/Output	I7 /SCS	I/O Strobe 7 Slave Port Chip Select
	14	PE6	Input/Output	I6	I/O Strobe 6
	15	PE5	Input/Output	I5 INT1B	I/O Strobe 5 Interrupt 1B
	16	PE4	Input/Output	I4 INT0B	I/O Strobe 4 Interrupt 0B
	17	PE3	Input/Output	I3	I/O Strobe 3
	18	PE1	Input/Output	I1 INT1A	I/O Strobe 1 Interrupt 1A
	19	PE0	Input/Output	I0 INT0A	I/O Strobe 0 Interrupt 0A

Table 2. RCM3900 Pinout Configurations (continued)

Pin	Pin Name	Default Use	Alternate Use	Notes	
Header J62	20	PG7	Input/Output	RXE	Serial Port E
	21	PG6	Input/Output	TXE	
	22	PG5	Input/Output	RCLKE	Serial Clock E input
	23	PG4	Input/Output	TCLKE	Serial Clock E ouput
	24	/IOWR	Output		External write strobe
	25	/IORD	Output		External read strobe
	26–27	SMODE0, SMODE1	(0,0)—start executing at address zero (0,1)—cold boot from slave port (1,0)—cold boot from clocked Serial Port A SMODE0 =1, SMODE1 = 1 Cold boot from asynchronous Serial Port A at 2400 bps (programming cable connected)		Also connected to programming cable
	28	/RESET_IN	Input		Input to Reset Generator
	29	VRAM	Output		See Notes below table
	30	VBAT_EXT	3 V battery Input		Minimum battery voltage 2.85 V
	31	+3.3 VIN	Power Input		3.15–3.45 V DC
	32	GND			
	33	n.c.			Reserved for future use
	34	GND			

Notes

1. When using pins 33–34 on header J3 to drive LEDs, these pins can handle a sinking current of up to 8 mA.
2. The VRAM voltage is temperature-dependent. If the VRAM voltage drops below about 1.2 V to 1.5 V, the contents of the battery-backed SRAM may be lost. If VRAM drops below 1.0 V, the 32 kHz oscillator could stop running. Pay careful attention to this voltage if you draw any current from this pin.
3. Do not overload the /IOWR line because the NAND flash memories have critical timing requirements. In some cases it may be necessary to buffer /IOWR on the motherboard.

4.1.1 Memory I/O Interface

The Rabbit 3000 address lines (A0–A18) and all the data lines (D0–D7) are routed internally to the onboard flash memory and SRAM chips. I/O write (/IOWR) and I/O read (/IORD) are available for interfacing to external devices—pay attention to the loading on these two signals if you use them since these signals are also used by the RCM3900.

Parallel Port A can also be used as an external I/O data bus to isolate external I/O from the main data bus. Parallel Port B pins PB2–PB7 can also be used as an auxiliary address bus.

When using the external I/O bus for a digital output or the LCD/keypad module on the Prototyping Board, or for any other reason, you must add the following line at the beginning of your program.

```
#define PORTA_AUX_IO // required to enable auxiliary I/O bus
```

4.1.2 LEDs

The RCM3900 has three Ethernet status LEDs located beside the RJ-45 Ethernet jack—these are discussed in Section 4.2.2.

Additionally, there is one dual LED DS4. PD1 on the Rabbit 3000's Parallel Port D is used to enable the NAND flash on the RCM3900 model, but is connected to the green **CE** LED at DS4, which is not used. The red **BSY** LED at DS4 is a user-programmable LED, and is controlled by PD0. The **CONTROLLEDS.C** and **FLASHLEDS.C** sample programs in the Dynamic C **SAMPLES\RCM3900** folder show how to set up and use this user-programmable LED.

4.1.3 Other Inputs and Outputs

The status, /RESET_IN, SMODE0, and SMODE1 I/O are normally associated with the programming port. Since the status pin is not used by the system once a program has been downloaded and is running, the status pin can then be used as a general-purpose CMOS output. The programming port is described in more detail in Section 4.2.3.

/RESET_IN is an external input used to reset the Rabbit 3000 microprocessor and the RCM3900 onboard peripheral circuits. /RES is an output from the reset circuitry that can be used to reset external peripheral devices.

4.2 Serial Communication

The RCM3900 does not have any serial protocol-level transceivers directly on the board. However, a serial interface may be incorporated into the board the RCM3900 is mounted on. For example, the Prototyping Board has RS-232 and RS-485 transceiver chips.

4.2.1 Serial Ports

There are six serial ports designated as Serial Ports A, B, C, D, E, and F. All six serial ports can operate in an asynchronous mode up to the baud rate of the system clock divided by 8. An asynchronous port can handle 7 or 8 data bits. A 9th bit address scheme, where an additional bit is sent to mark the first byte of a message, is also supported.

Serial Port A is normally used as a programming port, but may be used either as an asynchronous or as a clocked serial port once the RCM3900 has been programmed and is operating in the Run Mode.

Serial Port B is used as the SPI interface for the *miniSD™ Card*, and is not available for other use.

Serial Ports C and D can also be operated in the clocked serial mode. In this mode, a clock line synchronously clocks the data in or out. Either of the two communicating devices can supply the clock.

Serial Ports E and F can also be configured as HDLC serial ports. The IrDA protocol is also supported in SDLC format by these two ports.

4.2.2 Ethernet Port

Figure 7 shows the pinout for the RJ-45 Ethernet port (J3). Note that some Ethernet connectors are numbered in reverse to the order used here.

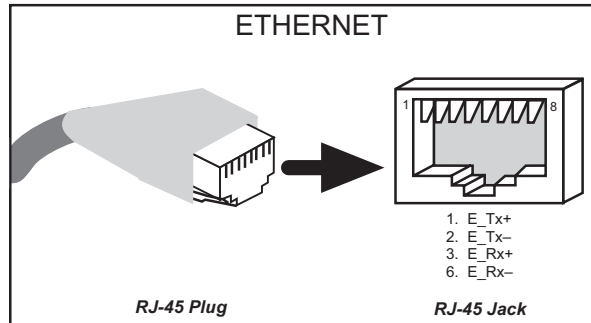

Figure 7. RJ-45 Ethernet Port Pinout

Three LEDs are placed next to the RJ-45 Ethernet jack, one to indicate Ethernet link/activity (**LNK/ACT**), one to indicate when the RCM3900 is connected to a functioning 100Base-T network (**SPD**), and one (**FDX/COL**) to indicate whether the Ethernet connection is in full-duplex mode (steady on) or that a half-duplex connection is experiencing collisions (blinks).

The transformer/connector assembly ground is connected to the RCM3900 printed circuit board digital ground via a ferrite bead, L1, as shown in Figure 8.

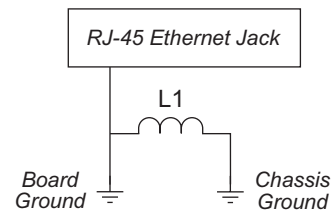

Figure 8. Ferrite Bead Isolation

The RJ-45 connector is shielded to minimize EMI effects to/from the Ethernet signals.

The Ethernet chip supports auto MDI/MDIX on the Ethernet port to choose the Ethernet interface automatically based on whether a crossover cable or a straight-through cable is used in a particular setup. The Ethernet chip may spike the current draw by up to 200 mA while it is searching to determine the type of Ethernet cable. This search is repeated every second if no Ethernet cable is detected. If you do not plan to connect an Ethernet cable, use the Dynamic C `pd_powerdown()` function call to turn off the Ethernet chip. The `pd_powerup()` function call is available to turn the Ethernet chip back on at a later time. These function calls are described in the *Dynamic C TCP/IP User's Manual, Volume 1*.

4.2.3 Serial Programming Port

The RCM3900 is programmed either through the serial programming port, which is accessed using header J1, or through the Ethernet jack. The RabbitLink may be used to provide a serial connection via the RabbitLink's Ethernet jack. The programming port uses the Rabbit 3000's Serial Port A for communication; Serial Port A is not used when programming is done over an Ethernet connection via the Dynamic C download manager. Dynamic C uses the programming port to download and debug programs.

The programming port is also used for the following operations.

- Cold-boot the Rabbit 3000 on the RCM3900 after a reset.
- Remotely download and debug a program over an Ethernet connection using the RabbitLink EG2110.
- Fast copy designated portions of flash memory from one Rabbit-based board (the master) to another (the slave) using the Rabbit Cloning Board.

In addition to Serial Port A, the Rabbit 3000 startup-mode (SMODE0, SMODE1), status, and reset pins are available on the serial programming port.

The two startup mode pins determine what happens after a reset—the Rabbit 3000 is either cold-booted or the program begins executing at address 0x0000.

The status pin is used by Dynamic C to determine whether a Rabbit microprocessor is present. The status output has three different programmable functions:

1. It can be driven low on the first op code fetch cycle.
2. It can be driven low during an interrupt acknowledge cycle.
3. It can also serve as a general-purpose CMOS output.

The /RESET_IN pin is an external input that is used to reset the Rabbit 3000 and the RCM3900 onboard peripheral circuits. The serial programming port can be used to force a hard reset on the RCM3900 by asserting the /RESET_IN signal.

Alternate Uses of the Serial Programming Port

All three clocked Serial Port A signals are available as

- a synchronous serial port
- an asynchronous serial port, with the clock line usable as a general CMOS I/O pin

The programming port may also be used as a serial port once the application is running. The SMODE pins may then be used as inputs and the status pin may be used as an output.

Refer to the *Rabbit 3000 Microprocessor User's Manual* for more information.

4.3 Serial Programming Cable

The programming cable is used to connect the serial programming port of the RCM3900 to a PC USB COM port. The programming cable converts the voltage levels used by the PC USB port to the CMOS voltage levels used by the Rabbit 3000.

When the **PROG** connector on the programming cable is connected to the RCM3900 serial programming port at header J1, programs can be downloaded and debugged over the serial interface.

The **DIAG** connector of the programming cable may be used on header J1 of the RCM3900 with the RCM3900 operating in the Run Mode. This allows the programming port to be used as a regular serial port.

4.3.1 Changing Between Program Mode and Run Mode

The RCM3900 is automatically in Program Mode when the **PROG** connector on the programming cable is attached, and is automatically in Run Mode when no programming cable is attached. When the Rabbit 3000 is reset, the operating mode is determined by the state of the SMODE pins. When the programming cable's **PROG** connector is attached, the SMODE pins are pulled high, placing the Rabbit 3000 in the Program Mode. When the programming cable's **PROG** connector is not attached, the SMODE pins are pulled low, causing the Rabbit 3000 to operate in the Run Mode.

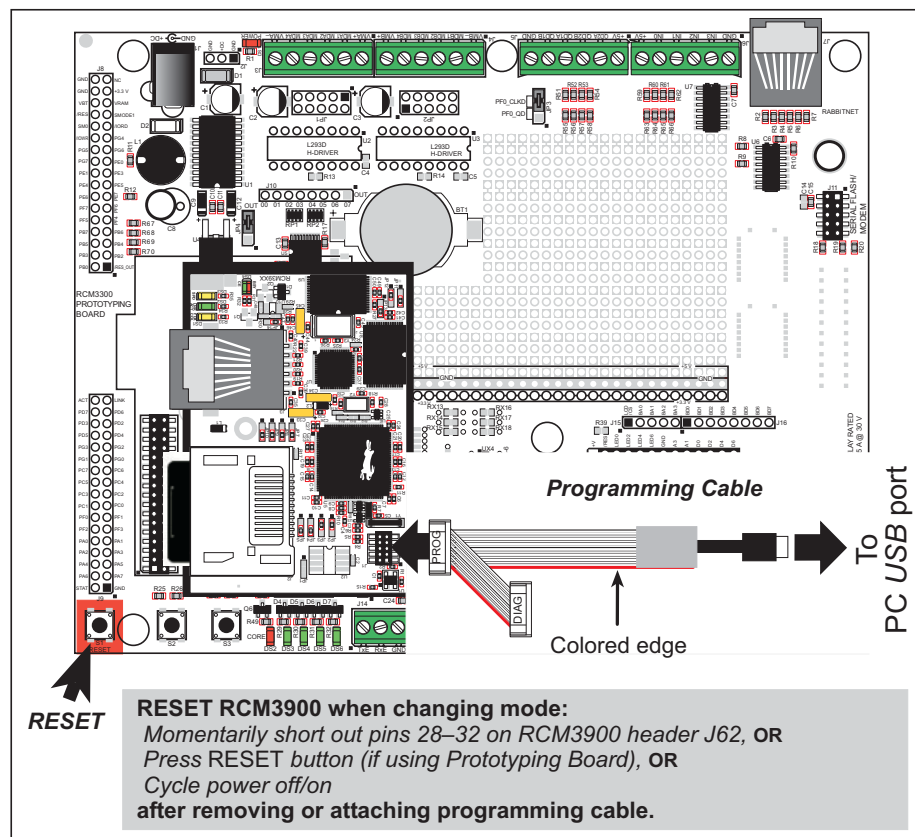

Figure 9. Switching Between Program Mode and Run Mode

A program “runs” in either mode, but can only be downloaded and debugged when the RCM3900 is in the Program Mode.

Refer to the *Rabbit 3000 Microprocessor User’s Manual* for more information on the programming port.

4.3.2 Standalone Operation of the RCM3900

The RCM3900 must be programmed via the Prototyping Board or via a similar arrangement on a customer-supplied board. Once the RCM3900 has been programmed successfully, remove the serial programming cable from the programming connector and reset the RCM3900. The RCM3900 may be reset by cycling the power off/on or by pressing the **RESET** button on the Prototyping Board. The RCM3900 module may now be removed from the Prototyping Board for end-use installation.

CAUTION: Disconnect power to the Prototyping Board or other boards when removing or installing your RCM3900 module to protect against inadvertent shorts across the pins or damage to the RCM3900 if the pins are not plugged in correctly. Do not reapply power until you have verified that the RCM3900 module is plugged in correctly.

4.4 Memory

4.4.1 SRAM

RCM3900 boards have 512K of program-execution fast SRAM at U66. The program-execution SRAM is not battery-backed. There are 512K of battery-backed data SRAM installed at U9.

4.4.2 Flash EPROM

RCM3900 boards also have 512K of flash EPROM at U8.

NOTE: Rabbit recommends that any customer applications should not be constrained by the sector size of the flash EPROM since it may be necessary to change the sector size in the future.

Writing to arbitrary flash memory addresses at run time is discouraged. Instead, use a portion of the “user block” area to store persistent data. The `writeUserBlock()` and `readUserBlock()` function calls are provided for this. Refer to the *Rabbit 3000 Microprocessor Designer’s Handbook* and the *Dynamic C Function Reference Manual* for additional information.

A Flash Memory Bank Select jumper configuration option based on 0 Ω surface-mounted resistors exists at header JP12 on the RCM3900 RabbitCore modules. This option, used in conjunction with some configuration macros, allows Dynamic C to compile two different co-resident programs for the upper and lower halves of a 256K flash in such a way that both programs start at logical address 0000. This option is not relevant to the RCM3900 RabbitCore modules, which use 512K flash memories.

4.4.3 NAND Flash (RCM3900 only)

The RCM3900 model has a NAND flash to store data and Web pages. The NAND flash is particularly suitable for mass-storage applications, but is generally unsuitable for direct program execution. The NAND flash differs from parallel NOR flash (the type of flash memory used to store program code on Rabbit-based boards and RabbitCore modules currently in production) in two respects. First, the NAND flash requires error-correcting code (ECC) for reliability. Although NAND flash manufacturers do guarantee that block 0 will be error-free, most manufacturers guarantee that a new NAND flash chip will be shipped with a relatively small percentage of errors, and will not develop more than some maximum number or percentage of errors over its rated lifetime of up to 100,000 writes. Second, the standard NAND flash addressing method multiplexes commands, data, and addresses on the same I/O pins, while requiring that certain control lines must be held stable for the duration of the NAND flash access. The software function calls provided by Rabbit for the NAND flash take care of the data-integrity and reliability attributes.

Sample programs in the `SAMPLES\RCM3900\NANDFlash` folder illustrate the use of the NAND flash. These sample programs are described in Section 3.2.1, “Use of NAND Flash (RCM3900 only).”

4.4.4 *miniSD*[™] Cards

The RCM3900 supports a removable *miniSD*[™] Card up to 1GB to store data and Web pages. The *miniSD*[™] Card is particularly suitable for mass-storage applications, but is generally unsuitable for direct program execution.

Unlike other flash devices, the *miniSD*[™] Card has some intelligence, which facilitates working with it. You do not have to worry about erased pages. All *miniSD*[™] Cards support 512-byte reads and writes, and handle any necessary pre-erasing internally.

The *miniSD*[™] Card socket on the RCM3900 has a plastic insert when shipped to protect the socket. This insert must be removed before you will be able to insert a *miniSD*[™] Card.

Figure 10 shows how to insert or remove the *miniSD*[™] Card. The card is designed to fit easily only one way — do **not** bend the card or force it into the slot. While you remove or insert the card, take care to avoid touching the electrical contacts on the bottom of the card to prevent electrostatic discharge damage to the card and to keep any moisture or other contaminants off the contacts. You will sense a soft click once the card is completely inserted. To remove it, gently press the card towards the middle of the RCM3900 — you will sense a soft click and the card will be ready to be removed. Do not attempt to pull the card from the socket before pressing it in — otherwise the ejection mechanism will get damaged. The ejection mechanism is spring-loaded, and will partially eject the card when used correctly.

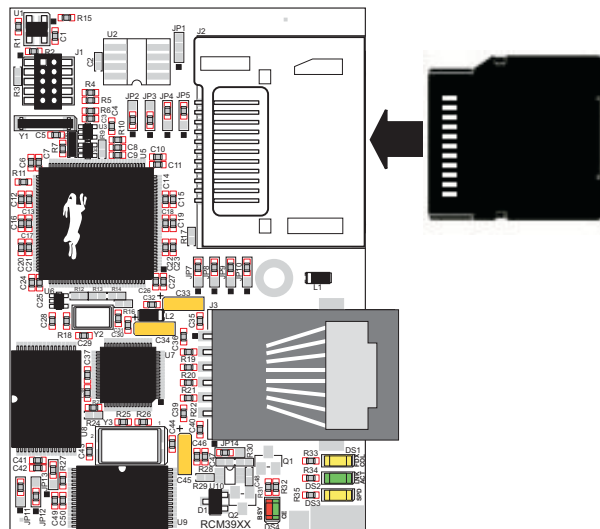

Figure 10. Insertion/Removal of *miniSD* Card

Rabbit recommends that you use the *miniSD*[™] Card holder at header J2 only for the *miniSD*[™] Card since other devices are not supported. Be careful to remove and insert the card as described, and be careful **not** to insert any foreign objects, which may short out the contacts and lead to the destruction of your card.

It is possible to hot-swap *miniSD*[™] Cards without removing power from the RCM3900 modules. The file system partition must be unmounted before the cards can be safely hot-

swapped. The chip selects associated with the card must be set to their inactive state, and read/write operations addressed to the *miniSD™ Card* port cannot be allowed to occur. These operations can be initiated in software by sensing an external switch actuated by the user, and the card can then be removed and replaced with a different one. Once the application program detects a new card, the file system partition can be remounted. These steps allow the *miniSD™ Card* to be installed or removed without affecting either the program, which continues to run on the RCM3900 module, or the data stored on the card. The Dynamic C FAT file system will handle this overhead automatically by unmounting the *miniSD™ Card*.

NOTE: When using the optional Dynamic C FAT file system module, do *not* remove or insert the *miniSD™ Card* while the *miniSD™ Card* is mounted.

You may add an LED to your design or use the **BSY** LED at DS4 to indicate when the *miniSD™ Card* is mounted. The LED can be set to turn off when the *miniSD™ Card* is unmounted, indicating that it is safe to remove it. The **BSY** LED at DS4 is controlled by PD0; your own LED would use an available parallel port I/O pin. The following macros in the Dynamic C `LIB\Rabbit3000\SDflash\SDFLASH.LIB` library will have to be modified to identify the parallel port pin and to specify the on/off conditions for the LED.

```
#define SD_LED_PORT_DR          PxDR // where x is the Parallel Port (A-E)
                                // 0 for no indicator LED
#define SD_LED_PORT_DRSHADOW  PxDRShadow // where x is the Parallel Port
                                // NULL for no indicator LED
#define SD_LED_PORT_FR          PxDFR // where x is the Parallel Port (A-E)
                                // 0 for no indicator LED
#define SD_LED_PORT_FRSHADOW  PxFRShadow // where x is the Parallel Port
                                // NULL for no indicator LED
#define SD_LED_PORT_DDR          PxDDR // where x is the Parallel Port (A-E)
                                // 0 for no indicator LED
#define SD_LED_PORT_DDRSHADOW PxDDRShadow // where x is the Parallel Port
                                // NULL for no indicator LED
#define SD_LED_PORT_DCR          PxCR // where x is the Parallel Port (A-E)
                                // 0 for no indicator LED
#define SD_LED_PORT_DCRSHADOW PxCRShadow // where x is the Parallel Port
                                // NULL for no indicator LED
#define SD_LED_PIN              n // Identify pin on parallel port (0-7)
                                // Use 0 for no indicator LED
#define SD_LED_PORT_OD          0 // LED is driven by transistor
                                // 1 to drive LED directly by open-drain output
#define SD_LED_PORT_ON          1 // 0 for no indicator LED or to drive LED
                                // directly by open-drain output, otherwise 1
```

Standard Windows SD Card readers may be used to read the *miniSD™ Card* formatted by the Dynamic C FAT file system with the RCM3900 as long as it has not been partitioned. An SD Card adapter is included with the *miniSD™ Card* in the in the RCM3900 Development Kit. The SD Card adapter has a sliding switch along the left side that may be moved down to write-protect the *miniSD™ Card* while it is being used with an SD Card reader.

Sample programs in the `SAMPLES\RCM3900\SD_Flash` folder illustrate the use of the *miniSD™ Cards*. These sample programs are described in Section 3.2.2, “Use of *miniSD™ Cards*.”

4.5 Other Hardware

4.5.1 Clock Doubler

The RCM3900 takes advantage of the Rabbit 3000 microprocessor's internal clock doubler. A built-in clock doubler allows half-frequency crystals to be used to reduce radiated emissions. The 44.2 MHz frequency specified for the RCM3900 is generated using a 22.12 MHz crystal.

The clock doubler may be disabled if 44.2 MHz clock speeds are not required. This will reduce power consumption and further reduce radiated emissions. The clock doubler is disabled with a simple configuration macro as shown below.

1. Select the “Defines” tab from the Dynamic C **Options > Project Options** menu.
2. Add the line `CLOCK_DOUBLED=0` to always disable the clock doubler.

The clock doubler is enabled by default, and usually no entry is needed. If you need to specify that the clock doubler is always enabled, add the line `CLOCK_DOUBLED=1` to always enable the clock doubler.

3. Click **OK** to save the macro. The clock doubler will now remain off whenever you are in the project file where you defined the macro.

4.5.2 Spectrum Spreader

The Rabbit 3000 features a spectrum spreader, which helps to mitigate EMI problems. The spectrum spreader is on by default, but it may also be turned off or set to a stronger setting. The means for doing so is through a simple configuration macro as shown below.

1. Select the “Defines” tab from the Dynamic C **Options > Project Options** menu.
2. Normal spreading is the default, and usually no entry is needed. If you need to specify normal spreading, add the line

```
ENABLE_SPREADER=1
```

For strong spreading, add the line

```
ENABLE_SPREADER=2
```

To disable the spectrum spreader, add the line

```
ENABLE_SPREADER=0
```

NOTE: The strong spectrum-spreading setting is not recommended since it may limit the maximum clock speed or the maximum baud rate. It is unlikely that the strong setting will be used in a real application.

3. Click **OK** to save the macro. The spectrum spreader will now be set to the state specified by the macro value whenever you are in the project file where you defined the macro.

NOTE: Refer to the *Rabbit 3000 Microprocessor User's Manual* for more information on the spectrum-spreading setting and the maximum clock speed.

5. SOFTWARE REFERENCE

Dynamic C is an integrated development system for writing embedded software. It runs on an IBM-compatible PC and is designed for use with Rabbit controllers and other controllers based on the Rabbit microprocessor. Chapter 5 describes the libraries and function calls related to the RCM3900.

5.1 More About Dynamic C

Dynamic C has been in use worldwide since 1989. It is specially designed for programming embedded systems, and features quick compile and interactive debugging. A complete reference guide to Dynamic C is contained in the *Dynamic C User's Manual*.

You have a choice of doing your software development in the flash memory or in the static SRAM included on the RCM3900. The flash memory and SRAM options are selected with the **Options > Program Options > Compiler** menu.

The advantage of working in RAM is to save wear on the flash memory, which is limited to about 100,000 write cycles. The disadvantage is that the code and data might not both fit in RAM.

NOTE: An application should be run from the program execution SRAM after the serial programming cable is disconnected. Your final code must always be stored in flash memory for reliable operation. RCM3900 modules have a fast program execution SRAM that is not battery-backed. Select **Code and BIOS in Flash, Run in RAM** from the Dynamic C **Options > Project Options > Compiler** menu to store the code in flash and copy it to the fast program execution SRAM at run-time to take advantage of the faster clock speed. This option optimizes the performance of RCM3900 modules running at 44.2 MHz.

NOTE: Do not depend on the flash memory sector size or type in your program logic. The RCM3900 and Dynamic C were designed to accommodate flash devices with various sector sizes in response to the volatility of the flash-memory market.

Developing software with Dynamic C is simple. Users can write, compile, and test C and assembly code without leaving the Dynamic C development environment. Debugging occurs while the application runs on the target. Alternatively, users can compile a program to an image file for later loading. Dynamic C runs on PCs under Windows 2000 and later—see Rabbit's Technical Note TN257, *Running Dynamic C® With Windows Vista®*, for additional information if you are using a Dynamic C release prior to v. 9.60 under Windows Vista. Programs can be downloaded at baud rates of up to 460,800 bps after the program compiles.

Dynamic C has a number of standard features.

- Full-feature source and/or assembly-level debugger, no in-circuit emulator required.
- Royalty-free TCP/IP stack with source code and most common protocols.
- Hundreds of functions in source-code libraries and sample programs:
 - ▶ Exceptionally fast support for floating-point arithmetic and transcendental functions.
 - ▶ RS-232 and RS-485 serial communication.
 - ▶ Analog and digital I/O drivers.
 - ▶ I²C, SPI, GPS, file system.
 - ▶ LCD display and keypad drivers.
- Powerful language extensions for cooperative or preemptive multitasking
- Loader utility program to load binary images into Rabbit targets in the absence of Dynamic C.
- Provision for customers to create their own source code libraries and augment on-line help by creating “function description” block comments using a special format for library functions.
- Standard debugging features:
 - ▶ Breakpoints—Set breakpoints that can disable interrupts.
 - ▶ Single-stepping—Step into or over functions at a source or machine code level, μ C/OS-II aware.
 - ▶ Code disassembly—The disassembly window displays addresses, opcodes, mnemonics, and machine cycle times. Switch between debugging at machine-code level and source-code level by simply opening or closing the disassembly window.
 - ▶ Watch expressions—Watch expressions are compiled when defined, so complex expressions including function calls may be placed into watch expressions. Watch expressions can be updated with or without stopping program execution.
 - ▶ Register window—All processor registers and flags are displayed. The contents of general registers may be modified in the window by the user.
 - ▶ Stack window—shows the contents of the top of the stack.
 - ▶ Hex memory dump—displays the contents of memory at any address.
 - ▶ **STDIO** window—`printf` outputs to this window and keyboard input on the host PC can be detected for debugging purposes. `printf` output may also be sent to a serial port or file.

5.1.1 Developing Programs Remotely with Dynamic C

Dynamic C is an integrated development environment that allows you to edit, compile, and debug your programs. Dynamic C has the ability to allow programming over the Internet or local Ethernet. This is accomplished in one of two ways.

1. Via the Rabbit RabbitLink, which allows a Rabbit-based target to have programs downloaded to it and debugged with the same ease as exists when the target is connected directly to a PC.
2. Dynamic C provides sample programs to illustrate the use of a download manager. The **DLM_TCP.C** and **DLP_TCP.C** sample programs found in the Dynamic C **SAMPLES\DOWN_LOAD** folder, are intended to be compiled to the program flash memory (which is a parallel flash memory). Custom applications based on these sample programs may use the NAND flash for data storage.

5.2 Dynamic C Functions

5.2.1 Digital I/O

The RCM3900 was designed to interface with other systems, and so there are no drivers written specifically for the I/O. The general Dynamic C read and write functions allow you to customize the parallel I/O to meet your specific needs. For example, use

```
WrPortI(PEDDR, &PEDDRShadow, 0x00);
```

to set all the Port E bits as inputs, or use

```
WrPortI(PEDDR, &PEDDRShadow, 0xFF);
```

to set all the Port E bits as outputs.

When using the external I/O bus on the Rabbit 3000 chip, add the line

```
#define PORTA_AUX_IO // required to enable auxiliary I/O bus
```

to the beginning of any programs using the auxiliary I/O bus.

The sample programs in the Dynamic C **SAMPLES/RCM3900** folder provide further examples.

5.2.2 SRAM Use

The RCM3900 has a battery-backed data SRAM and a program-execution SRAM. Dynamic C provides the **protected** keyword to identify variables that are to be placed into the battery-backed SRAM. The compiler generates code that creates a backup copy of a protected variable before the variable is modified. If the system resets while the protected variable is being modified, the variable's value can be restored when the system restarts.

The sample code below shows how a protected variable is defined and how its value can be restored.

```
protected nf_device nandFlash;
int main() {
    ...
    _sysIsSoftReset(); // restore any protected variables
```

The **bbram** keyword may be used instead if there is a need to store a variable in battery-backed SRAM without affecting the performance of the application program. Data integrity is *not* assured when a reset or power failure occurs during the update process.

Additional information on **bbram** and **protected** variables is available in the *Dynamic C User's Manual*.

5.2.3 Serial Communication Drivers

Library files included with Dynamic C provide a full range of serial communications support. The `LIB\Rabbit3000\RS232.LIB` library provides a set of circular-buffer-based serial functions. The `LIB\Rabbit3000\PACKET.LIB` library provides packet-based serial functions where packets can be delimited by the 9th bit, by transmission gaps, or with user-defined special characters. Both libraries provide blocking functions, which do not return until they are finished transmitting or receiving, and nonblocking functions, which must be called repeatedly until they are finished, allowing other functions to be performed between calls. For more information, see the *Dynamic C Function Reference Manual* and Technical Note TN213, *Rabbit Serial Port Software*.

5.2.4 TCP/IP Drivers

The TCP/IP drivers are located in the `LIB\Rabbit3000\TCPIP` folder. Complete information on these libraries and the TCP/IP functions is provided in the *Dynamic C TCP/IP User's Manual*.

5.2.5 NAND Flash Drivers

The Dynamic C `LIB\Rabbit3000\NANDFlash\NFLASH.LIB` library is used to interface to NAND flash memory devices on the RCM3900. The function calls were written specifically to work with industry-standard flash devices with a 528-byte page program and 16896-byte block erase size. The NAND flash function calls are designed to be closely cross-compatible with the newer serial flash function calls found in the `LIB\Rabbit3000\SFLASH.LIB` library. These function calls use an `nf_device` structure as a handle for a specific NAND flash device. This allows multiple NAND flash devices to be used by an application.

More information on these function calls is available in the *Dynamic C Function Reference Manual*.

The NAND flash is ideally suited to store files with a directory structure. The Dynamic C FAT file system module provides support for a file system for use in a Rabbit-based system. The supporting documentation for the Dynamic C FAT File System and the sample programs in the `SAMPLES\FileSystem\FAT` folder illustrate the use of the Dynamic C FAT file system.

5.2.6 *miniSD*[™] Card Drivers

The Dynamic C `LIB\SDF1ash\SDFLASH.LIB` library is used to interface to *miniSD*[™] Card memory devices on an SPI bus. More information on these function calls is available in the *Dynamic C Function Reference Manual*.

Application developers are cautioned against modifying the BIOS code to insert application-specific external I/O (IOE) instructions before the GOCR register and its shadow are initialized by the standard BIOS code. Such IOE code will cause the *miniSD*[™] Card select to toggle, possibly interfering with the *miniSD*[™] Card operation.

The *miniSD*[™] Card is ideally suited to store files with a directory structure. The Dynamic C FAT file system included with Dynamic C provides support for a file system and for formatting the *miniSD*[™] Card for use in a Rabbit-based system. This allows files to be read and written in a PC-compatible manner. The supporting documentation for the Dynamic C FAT File System and the sample programs in the `SAMPLES\FileSystem\FAT` folder illustrate the use of the Dynamic C FAT file system.

NOTE: Dynamic C has a utility for partitioning storage devices. Rabbit recommends that you do not partition the *miniSD*[™] Card since doing so would make it not PC-compatible.

5.2.7 Prototyping Board Function Calls

The functions described in this section are for use with the Prototyping Board features. The source code is in the Dynamic C `SAMPLES\RCM3900\RCM39xx.LIB` library if you need to modify it for your own board design.

Other generic functions applicable to all devices based on Rabbit microprocessors are described in the *Dynamic C Function Reference Manual*.

5.2.7.1 Board Initialization

`brdInit`

```
void brdInit (void);
```

DESCRIPTION

Call this function at the beginning of your program. This function initializes Parallel Ports A through G for use with the Prototyping Board.

This function call is intended for demonstration purposes only, and can be modified for your applications.

Summary of Initialization

1. I/O port pins are configured for Prototyping Board operation.
2. Unused configurable I/O are set as tied inputs or outputs.
3. The external I/O bus is enabled.
4. The LCD/keypad module is disabled.
5. RS-485 is not enabled.
6. RS-232 is not enabled.
7. LEDs are off.
8. Ethernet select is disabled.
9. Motor control is disabled.
10. The relay is set to normally closed positions.

RETURN VALUE

None.

5.2.7.2 Digital I/O

digIn

```
int digIn(int channel);
```

DESCRIPTION

Reads the input state of a digital input on headers J5 and J6 on the Prototyping Board.

Do not use this function call if you configure these pins for alternate use after `brdInit()` is called.

A runtime error will occur if `brdInit()` has not been called first.

PARAMETER

channel	the channel number corresponding to the digital input channel:
	0—IN0
	1—IN1
	2—IN2
	3—IN3
	4—QD1B
	5—QD1A
	6—QD2B
	7—QD2A

RETURN VALUE

The logic state (0 or 1) of the input. A run-time error will occur if the `channel` parameter is out of range.

SEE ALSO

`brdInit`

digOut

```
void digOut(int channel, int value);
```

DESCRIPTION

Writes a value to an output channel on Prototyping Board header J10. Do not use this function if you have installed the stepper motor chips at U2 and U3.

PARAMETERS

channel	output channel 0–7 (OUT00–OUT07).
value	value (0 or 1) to output.

RETURN VALUE

None.

SEE ALSO

`brdInit`

5.2.7.3 Switches, LEDs, and Relay

switchIn

```
int switchIn(int swin);
```

DESCRIPTION

Reads the state of a switch input.

A runtime error will occur if `brdInit()` has not been called first or if the `swin` parameter is invalid.

PARAMETERS

<code>swin</code>	switch input to read:
	2—S2
	3—S3

RETURN VALUE

State of the switch input:

1 = open

0 = closed

SEE ALSO

`brdInit`

ledOut

```
void ledOut(int led, int value);
```

DESCRIPTION

Controls LEDs on the Prototyping Board and on the RCM3900.

A runtime error will occur if `brdInit()` has not been called first.

PARAMETERS

led the LED to control:
 0 = red **BSY** LED on RCM3900
 3 = DS3 on Prototyping Board
 4 = DS4 on Prototyping Board
 5 = DS5 on Prototyping Board
 6 = DS6 on Prototyping Board

value the value used to control the LED:
 0 = off
 1 = on

RETURN VALUE

None.

SEE ALSO

`brdInit`

relayOut

```
void relayOut(int relay, int value);
```

DESCRIPTION

Sets the position for the relay common contact. The default position is for normally closed contacts.

A runtime error will occur if **brdInit ()** has not been called first.

PARAMETERS

relay	the one relay (1)
value	the value used to connect the relay common contact: 0 = normally closed positions (NC1 and NC2) 1 = normally open positions (NO1 and NO2)

RETURN VALUE

None.

SEE ALSO

brdInit

5.2.7.4 Serial Communication

ser485Tx

```
void ser485Tx(void);
```

DESCRIPTION

Enables the RS-485 transmitter. Transmitted data are echoed back into the receive data buffer. The echoed data may be used as an indicator for disabling the transmitter by using one of the following methods:

Byte mode—disable the transmitter after the same byte that is transmitted is detected in the receive data buffer.

Block data mode—disable the transmitter after the same number of bytes transmitted are detected in the receive data buffer.

Remember to call the **serXopen()** function before running this function.

RETURN VALUE

None.

SEE ALSO

ser485Rx

ser485Rx

```
void ser485Rx(void);
```

DESCRIPTION

Disables the RS-485 transmitter. This puts the device into the listen mode, which allows it to receive data from the RS-485 interface.

Remember to call the **serXopen()** function before running this function.

RETURN VALUE

None.

SEE ALSO

ser485Tx

5.3 Upgrading Dynamic C

Dynamic C patches that focus on bug fixes are available from time to time. Check the Web site www.rabbit.com/support/ for the latest patches, workarounds, and bug fixes.

5.3.1 Extras

Dynamic C installations are designed for use with the board they are included with, and are included at no charge as part of our low-cost kits.

Starting with Dynamic C version 9.60, which is included with the RCM3900 Development Kit, Dynamic C includes the popular μ C/OS-II real-time operating system, point-to-point protocol (PPP), FAT file system, RabbitWeb, and other select libraries. Rabbit also offers for purchase the Rabbit Embedded Security Pack featuring the Secure Sockets Layer (SSL) and a specific Advanced Encryption Standard (AES) library.

In addition to the Web-based technical support included at no extra charge, a one-year telephone-based technical support subscription is also available for purchase.

Visit our Web site at www.rabbit.com for further information and complete documentation.

6. USING THE TCP/IP FEATURES

6.1 TCP/IP Connections

Programming and development can be done with the RCM3900 modules without connecting the Ethernet port to a network. However, if you will be running the sample programs that use the Ethernet capability or will be doing Ethernet-enabled development, you should connect the RCM3900 module's Ethernet port at this time.

Before proceeding you will need to have the following items.

- If you don't have Ethernet access, you will need at least a 10Base-T Ethernet card (available from your favorite computer supplier) installed in a PC.
- One Cat. 5 straight through or crossover Ethernet cable.

A Cat. 5 straight-through and a Cat. 5 crossover Ethernet cable are included in the RCM3900 Development Kit. Figure 11 shows how to identify the two cables based on the wires in the transparent RJ-45 connectors.

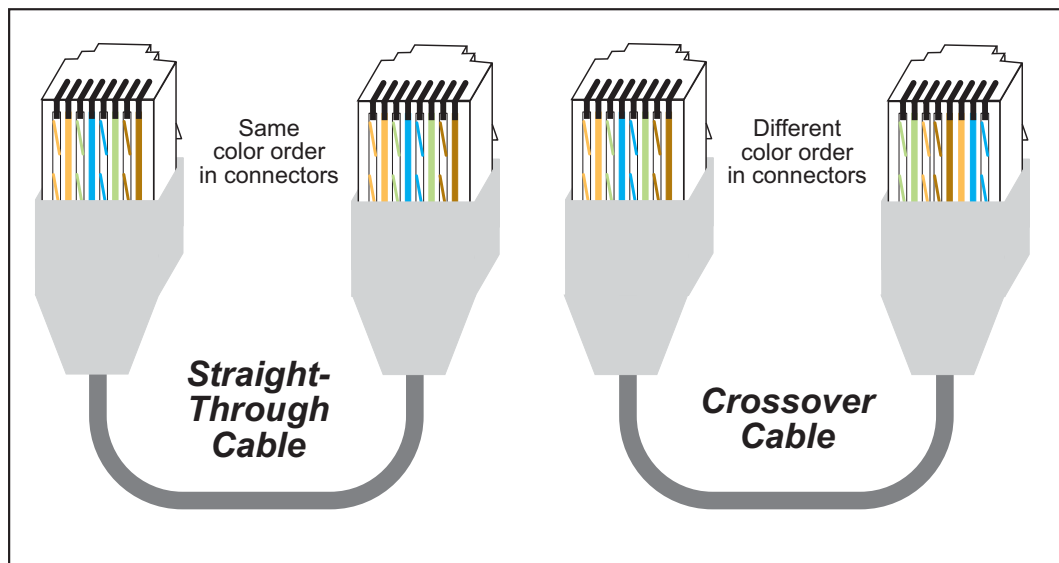

Figure 11. How to Identify Straight-Through and Crossover Ethernet Cables

Ethernet cables and a 10Base-T Ethernet hub are available in a TCP/IP tool kit. More information is available at www.rabbit.com.

Now you should be able to make your connections.

1. Connect the AC adapter and the programming cable as shown in Chapter 2, “Getting Started.”

2. Ethernet Connections

There are four options for connecting the RCM3900 module to a network for development and runtime purposes. The first two options permit total freedom of action in selecting network addresses and use of the “network,” as no action can interfere with other users. We recommend one of these options for initial development.

- **No LAN** — The simplest alternative for desktop development. Connect the RCM3900 module’s Ethernet port directly to the PC’s network interface card using either a Cat. 5 *crossover* cable or a Cat. 5 *straight-through* cable.
- **Micro-LAN** — Another simple alternative for desktop development. Use a small Ethernet 10Base-T hub and connect both the PC’s network interface card and the RCM3900 module’s Ethernet port to it using standard network cables.

The following options require more care in address selection and testing actions, as conflicts with other users, servers and systems can occur:

- **LAN** — Connect the RCM3900 module’s Ethernet port to an existing LAN, preferably one to which the development PC is already connected. You will need to obtain IP addressing information from your network administrator.
- **WAN** — The RCM3900 is capable of direct connection to the Internet and other Wide Area Networks, but exceptional care should be used with IP address settings and all network-related programming and development. We recommend that development and debugging be done on a local network before connecting a RabbitCore system to the Internet.

TIP: Checking and debugging the initial setup on a micro-LAN is recommended before connecting the system to a LAN or WAN.

The PC running Dynamic C does not need to be the PC with the Ethernet card.

3. Apply Power

Plug in the AC adapter. The RCM3900 module and Prototyping Board are now ready to be used.

6.2 TCP/IP Primer on IP Addresses

Obtaining IP addresses to interact over an existing, operating, network can involve a number of complications, and must usually be done with cooperation from your ISP and/or network systems administrator. For this reason, it is suggested that the user begin instead by using a direct connection between a PC and the RCM3900.

In order to set up this direct connection, you will have to use a PC without networking, or disconnect a PC from the corporate network, or install a second Ethernet adapter and set up a separate private network attached to the second Ethernet adapter. Disconnecting your PC from the corporate network may be easy or nearly impossible, depending on how it is set up. If your PC boots from the network or is dependent on the network for some or all of its disks, then it probably should not be disconnected. If a second Ethernet adapter is used, be aware that Windows TCP/IP will send messages to one adapter or the other, depending on the IP address and the binding order in Microsoft products. Thus you should have different ranges of IP addresses on your private network from those used on the corporate network. If both networks service the same IP address, then Windows may send a packet intended for your private network to the corporate network. A similar situation will take place if you use a dial-up line to send a packet to the Internet. Windows may try to send it via the local Ethernet network if it is also valid for that network.

The following IP addresses are set aside for local networks and are not allowed on the Internet: 10.0.0.0 to 10.255.255.255, 172.16.0.0 to 172.31.255.255, and 192.168.0.0 to 192.168.255.255.

The RCM3900 uses a 10/100-compatible Ethernet connection. The RJ-45 connectors are similar to U.S. style telephone connectors, except they are larger and have 8 contacts.

An alternative to the direct connection is a connection using a hub. The hub relays packets received on any port to all of the ports on the hub. Hubs are low in cost and are readily available. The RCM3900 uses 10/100 Mbps Ethernet, so the hub or Ethernet adapter should be a 10/100 Mbps unit.

In a corporate setting where the Internet is brought in via a high-speed line, there are typically machines between the outside Internet and the internal network. These machines include a combination of proxy servers and firewalls that filter and multiplex Internet traffic. In the configuration below, the RCM3900 could be given a fixed address so any of the computers on the local network would be able to contact it. It may be possible to configure the firewall or proxy server to allow hosts on the Internet to directly contact the controller, but it would probably be easier to place the controller directly on the external network outside of the firewall. This avoids some configuration complications by sacrificing some security.

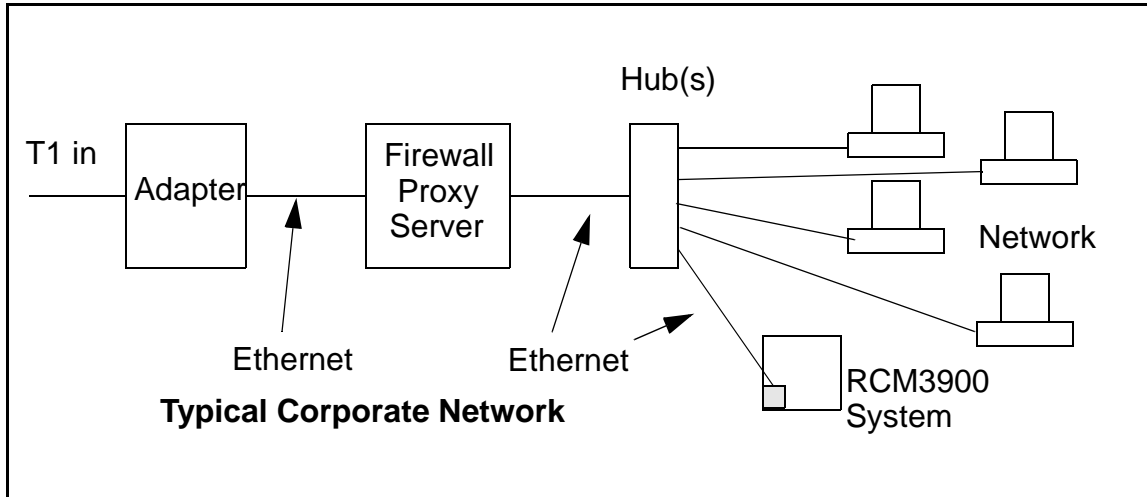

If your system administrator can give you an Ethernet cable along with the network IP address, the netmask and the gateway address, then you may be able to run the sample programs without having to setup a direct connection between your computer and the RCM3900. You will also need the IP address of the nameserver, the name or IP address of your mail server, and your domain name for some of the sample programs.

6.2.1 IP Addresses Explained

IP (Internet Protocol) addresses are expressed as 4 decimal numbers separated by periods, for example:

216.103.126.155

10.1.1.6

Each decimal number must be between 0 and 255. The total IP address is a 32-bit number consisting of the 4 bytes expressed as shown above. A local network uses a group of adjacent IP addresses. There are always 2^N IP addresses in a local network. The netmask (also called subnet mask) determines how many IP addresses belong to the local network. The netmask is also a 32-bit address expressed in the same form as the IP address. An example netmask is:

255.255.255.0

This netmask has 8 zero bits in the least significant portion, and this means that 2^8 addresses are a part of the local network. Applied to the IP address above (216.103.126.155), this netmask would indicate that the following IP addresses belong to the local network:

216.103.126.0

216.103.126.1

216.103.126.2

etc.

216.103.126.254

216.103.126.255

The lowest and highest address are reserved for special purposes. The lowest address (216.102.126.0) is used to identify the local network. The highest address (216.102.126.255) is used as a broadcast address. Usually one other address is used for the address of the gateway out of the network. This leaves $256 - 3 = 253$ available IP addresses for the example given.

6.2.2 How IP Addresses are Used

The actual hardware connection via an Ethernet uses Ethernet adapter addresses (also called MAC addresses). These are 48-bit addresses and are unique for every Ethernet adapter manufactured. In order to send a packet to another computer, given the IP address of the other computer, it is first determined if the packet needs to be sent directly to the other computer or to the gateway. In either case, there is an Ethernet address on the local network to which the packet must be sent. A table is maintained to allow the protocol driver to determine the MAC address corresponding to a particular IP address. If the table is empty, the MAC address is determined by sending an Ethernet broadcast packet to all devices on the local network asking the device with the desired IP address to answer with its MAC address. In this way, the table entry can be filled in. If no device answers, then the device is nonexistent or inoperative, and the packet cannot be sent.

Some IP address ranges are reserved for use on internal networks, and can be allocated freely as long as no two internal hosts have the same IP address. These internal IP addresses are not routed to the Internet, and any internal hosts using one of these reserved IP addresses cannot communicate on the external Internet without being connected to a host that has a valid Internet IP address. The host would either translate the data, or it would act as a proxy.

Each RCM3900 RabbitCore module has its own unique MAC address, which consists of the prefix 0090C2 followed by a code that is unique to each RCM3900 module. For example, a MAC address might be 0090C2C002C0.

TIP: You can always obtain the MAC address on your board by running the sample program `DISPLAY_MAC.C` from the `SAMPLES\TCPIP` folder.

6.2.3 Dynamically Assigned Internet Addresses

In many instances, devices on a network do not have fixed IP addresses. This is the case when, for example, you are assigned an IP address dynamically by your dial-up Internet service provider (ISP) or when you have a device that provides your IP addresses using the Dynamic Host Configuration Protocol (DHCP). The RCM3900 modules can use such IP addresses to send and receive packets on the Internet, but you must take into account that this IP address may only be valid for the duration of the call or for a period of time, and could be a private IP address that is not directly accessible to others on the Internet. These addresses can be used to perform some Internet tasks such as sending e-mail or browsing the Web, but it is more difficult to participate in conversations that originate elsewhere on the Internet. If you want to find out this dynamically assigned IP address, under Windows 98 you can run the `winiptcfg` program while you are connected and look at the interface used to connect to the Internet.

Many networks use IP addresses that are assigned using DHCP. When your computer comes up, and periodically after that, it requests its networking information from a DHCP server. The DHCP server may try to give you the same address each time, but a fixed IP address is usually not guaranteed.

If you are not concerned about accessing the RCM3900 from the Internet, you can place the RCM3900 on the internal network using an IP address assigned either statically or through DHCP.

6.3 Placing Your Device on the Network

In many corporate settings, users are isolated from the Internet by a firewall and/or a proxy server. These devices attempt to secure the company from unauthorized network traffic, and usually work by disallowing traffic that did not originate from inside the network. If you want users on the Internet to communicate with your RCM3900, you have several options. You can either place the RCM3900 directly on the Internet with a real Internet address or place it behind the firewall. If you place the RCM3900 behind the firewall, you need to configure the firewall to translate and forward packets from the Internet to the RCM3900.

6.4 Running TCP/IP Sample Programs

We have provided a number of sample programs demonstrating various uses of TCP/IP for networking embedded systems. These programs require you to connect your PC and the RCM3900 board together on the same network. This network can be a local private network (preferred for initial experimentation and debugging), or a connection via the Internet.

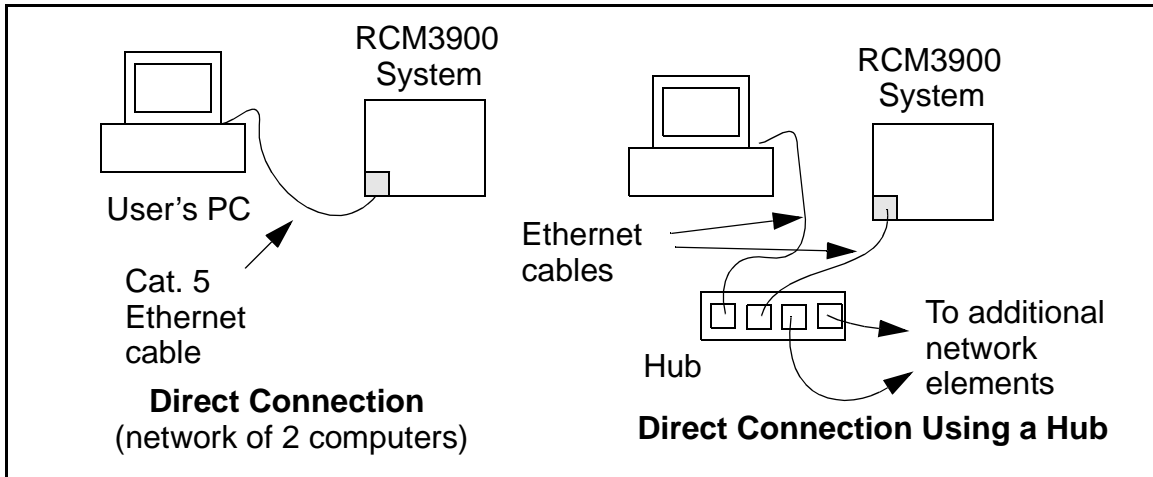

6.4.1 How to Set IP Addresses in the Sample Programs

With the introduction of Dynamic C 7.30 we have taken steps to make it easier to run many of our sample programs. You will see a **TCPCONFIG** macro. This macro tells Dynamic C to select your configuration from a list of default configurations. You will have three choices when you encounter a sample program with the **TCPCONFIG** macro.

1. You can replace the **TCPCONFIG** macro with individual **MY_IP_ADDRESS**, **MY_NETMASK**, **MY_GATEWAY**, and **MY_NAMESERVER** macros in each program.
2. You can leave **TCPCONFIG** at the usual default of 1, which will set the IP configurations to **10.10.6.100**, the netmask to **255.255.255.0**, and the nameserver and gateway to **10.10.6.1**. If you would like to change the default values, for example, to use an IP address of **10.1.1.2** for the RCM3900 board, and **10.1.1.1** for your PC, you can edit the values in the section that directly follows the “General Configuration” comment in the **TCP_CONFIG.LIB** library. You will find this library in the **LIB\TCPIP** directory.
3. You can create a **CUSTOM_CONFIG.LIB** library and use a **TCPCONFIG** value greater than 100. Instructions for doing this are at the beginning of the **TCP_CONFIG.LIB** library in the **LIB\TCPIP** directory.

There are some other “standard” configurations for **TCPCONFIG** that let you select different features such as DHCP. Their values are documented at the top of the **TCP_CONFIG.LIB** library in the **LIB\TCPIP** directory. More information is available in the *Dynamic C TCP/IP User’s Manual*.

6.4.2 How to Set Up your Computer for Direct Connect

Follow these instructions to set up your PC or notebook. Check with your administrator if you are unable to change the settings as described here since you may need administrator privileges. The instructions are specifically for Windows 2000, but the interface is similar for other versions of Windows.

TIP: If you are using a PC that is already on a network, you will disconnect the PC from that network to run these sample programs. Write down the existing settings before changing them to facilitate restoring them when you are finished with the sample programs and reconnect your PC to the network.

1. Go to the control panel (**Start > Settings > Control Panel**), and then double-click the Network icon.
2. Select the network interface card used for the Ethernet interface you intend to use (e.g., **TCP/IP Xircom Credit Card Network Adapter**) and click on the “Properties” button. Depending on which version of Windows your PC is running, you may have to select the “Local Area Connection” first, and then click on the “Properties” button to bring up the Ethernet interface dialog. Then “Configure” your interface card for a “10Base-T Half-Duplex” or an “Auto-Negotiation” connection on the “Advanced” tab.

NOTE: Your network interface card will likely have a different name.

3. Now select the **IP Address** tab, and check **Specify an IP Address**, or select TCP/IP and click on “Properties” to assign an IP address to your computer (this will disable “obtain an IP address automatically”):

IP Address : 10.10.6.101

Netmask : 255.255.255.0

Default gateway : 10.10.6.1

4. Click **<OK>** or **<Close>** to exit the various dialog boxes.

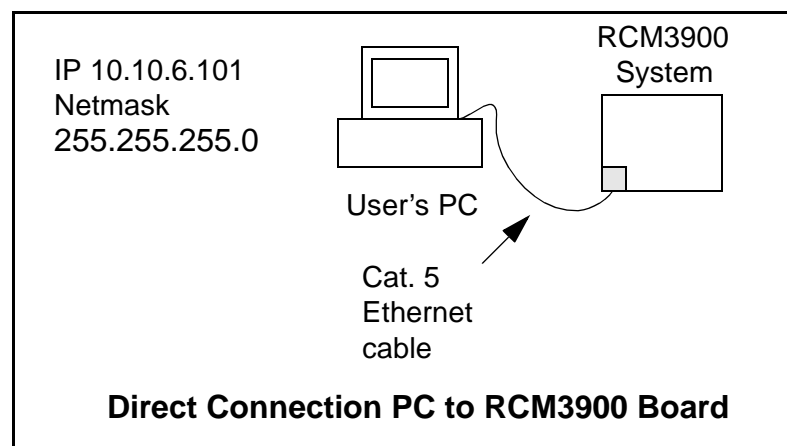

6.5 Run the `PINGME.C` Sample Program

Connect a Cat. 5 Ethernet cable from your computer's Ethernet port to the RCM3900 board's RJ-45 Ethernet connector. Open this sample program from the `SAMPLES\TCPIP\ICMP` folder, compile the program, and start it running under Dynamic C. When the program starts running, the green **LNK/ACT** light on the RCM3900 module should be on to indicate an Ethernet connection is made. (Note: If the **LNK/ACT** light does not light and you are using a hub, check that the power is not off on the hub.)

The next step is to ping the board from your PC. This can be done by bringing up the MS-DOS window and running the pingme program:

```
ping 10.10.6.100
```

or by **Start > Run**

and typing the entry

```
ping 10.10.6.100
```

Notice that the green **LNK/ACT** light flashes on the RCM3900 module while the ping is taking place, and indicates the transfer of data. The ping routine will ping the board four times and write a summary message on the screen describing the operation.

6.6 Running Additional Sample Programs With Direct Connect

The sample programs discussed here are in the Dynamic C `SAMPLES\RCM3900\TCPIP\` folder.

The program `BROWSELED.C` demonstrates how to make the RCM3900 board be a Web server. Two "LEDs" are created on the Web page, along with two buttons to toggle them. Users can change the status of the lights from the Web browser. The LEDs on the Prototyping Board match the ones on the Web page. As long as you have not modified the `TCPCONFIG 1` macro in the sample program, enter the following server address in your Web browser to bring up the Web page served by the sample program.

```
http://10.10.6.100.
```

Otherwise use the TCP/IP settings you entered in the `TCP_CONFIG.LIB` library.

The optional LCD/keypad module (see Appendix C) must be plugged in to the RCM3900 Prototyping Board when using this sample program. The sample program `MBOXDEMO.C` implements a Web server that allows e-mail messages to be entered and then shown on the LCD/keypad module. The keypad allows the user to scroll within messages, flip to other e-mails, mark messages as read, and delete e-mails. When a new e-mail arrives, an LED (on the Prototyping Board and LCD/keypad module) turns on, then turns back off once the message has been marked as read. A log of all e-mail actions is kept, and can be displayed in the Web browser. All current e-mails can also be read with the Web browser.

The sample program `PINGLED.C` demonstrates ICMP by pinging a remote host. It will flash LEDs DS1 and DS2 on the Prototyping Board when a ping is sent and received.

The sample program **SMTP.C** allows you to send an e-mail when a switch on the Prototyping Board is pressed. Follow the instructions included with the sample program. LED DS1 on the Prototyping Board will light up when sending e-mail. Note that pin PB7 is connected to both switch S2 and to the external I/O bus on the Prototyping Board, and so switch S2 should not be used with Ethernet operations.

6.6.1 RabbitWeb Sample Programs

The sample programs can be found in the **SAMPLES\RCM3900\TCPIP\RABBITWEB** folder.

- **BLINKLEDS.C**—This program demonstrates a basic example to change the rate at which the DS1 and DS2 LEDs on the Prototyping Board blink.
- **DOORMONITOR.C**—The optional LCD/keypad module (see Appendix C) must be plugged in to the RCM3900 Prototyping Board when using this sample program. This program demonstrates adding and monitoring passwords entered via the LCD/keypad module.
- **SPRINKLER.C**—This program demonstrates how to schedule times for the digital outputs in a 24-hour period using the Prototyping Board.

The Web page uses the following setup.

- ▶ Station 1 is connected to the relay on Prototyping Board header J17.
- ▶ Station 2 is connected to OUT00 on Prototyping Board header J10.
- ▶ Station 3 is connected to OUT01 on Prototyping Board header J10.
- ▶ Zones 1, 2 and 3 are watering areas where stations are turned on or off at different times.

The **Pages/sprinkler.zhtml** page associated with this sample program demonstrates the corresponding scripting features.

The real-time clock must be set before you compile and run this sample program — see Section 3.2.4 for information on sample programs that show how to set the real-time clock.

Once you compile and run this sample program, open the Web page, enter the times for the various zones and stations, then press the **Submit** button to update the settings.

You may connect Rabbit's Demonstration Board to the Prototyping Board's relay and two outputs to view the on and off intervals via the LEDs on the Demonstration Board. The Demonstration Board is not included with the Development Kit, but may be purchased separately

6.7 Where Do I Go From Here?

NOTE: If you purchased your RCM3900 through a distributor or through a Rabbit partner, contact the distributor or partner first for technical support.

If there are any problems at this point:

- Use the Dynamic C **Help** menu to get further assistance with Dynamic C.
- Check the Rabbit Technical Bulletin Board and forums at www.rabbit.com/support/bb/ and at www.rabbit.com/forums/.
- Use the Technical Support e-mail form at www.rabbit.com/support/.

If the sample programs ran fine, you are now ready to go on.

Additional sample programs are described in the *Dynamic C TCP/IP User's Manual*.

Please refer to the *Dynamic C TCP/IP User's Manual* to develop your own applications. *An Introduction to TCP/IP* provides background information on TCP/IP, and is available on the CD and on our [Web site](#).



APPENDIX A. RCM3900 SPECIFICATIONS

Appendix A provides the specifications for the RCM3900, and describes the conformal coating.

A.1 Electrical and Mechanical Characteristics

Figure A-1 shows the mechanical dimensions for the RCM3900.

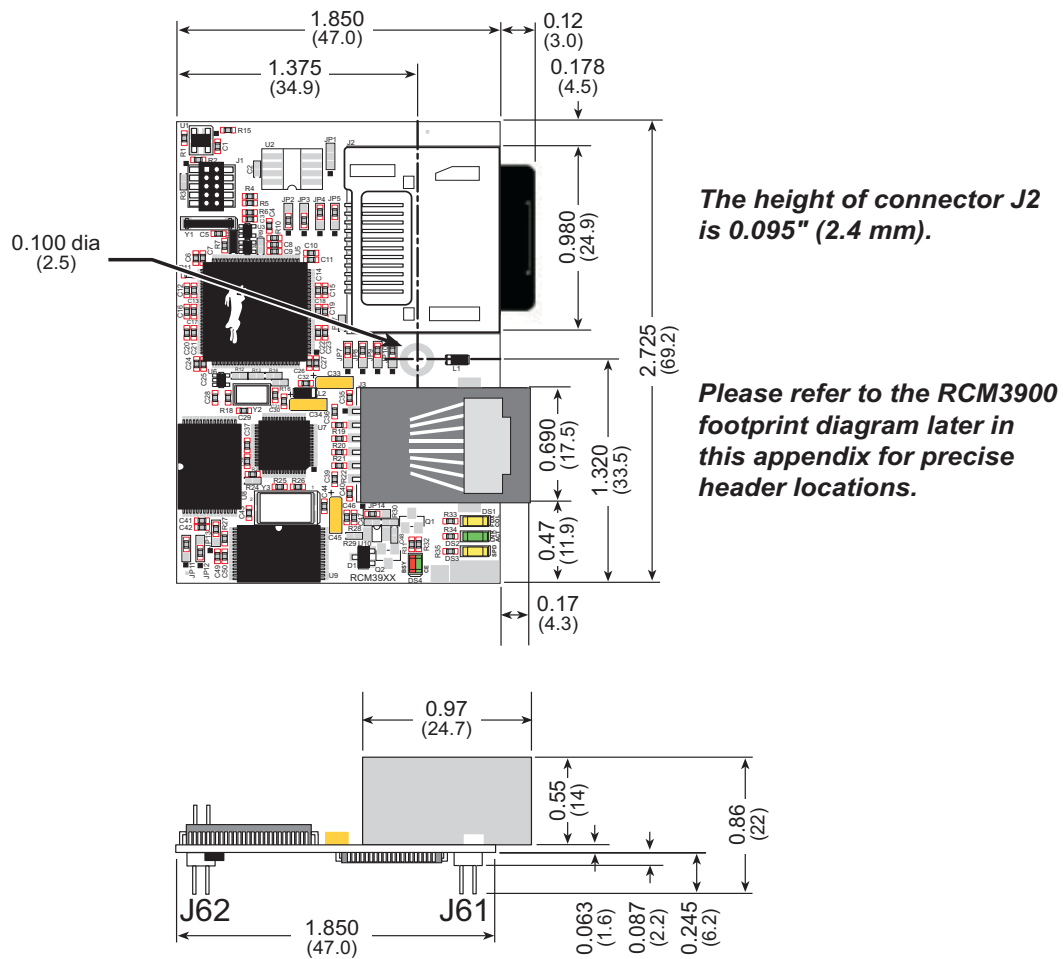

Figure A-1. RCM3900 Dimensions

NOTE: All measurements are in inches followed by millimeters enclosed in parentheses. All dimensions have a manufacturing tolerance of ± 0.01 " (0.2 mm).

It is recommended that you allow for an “exclusion zone” of 0.04" (1 mm) around the RCM3900 in all directions when the RCM3900 is incorporated into an assembly that includes other printed circuit boards. An “exclusion zone” of 0.16" (4 mm) is recommended below the RCM3900 when the RCM3900 is plugged into another assembly using the shortest connectors for header J1. Figure A-2 shows this “exclusion zone.”

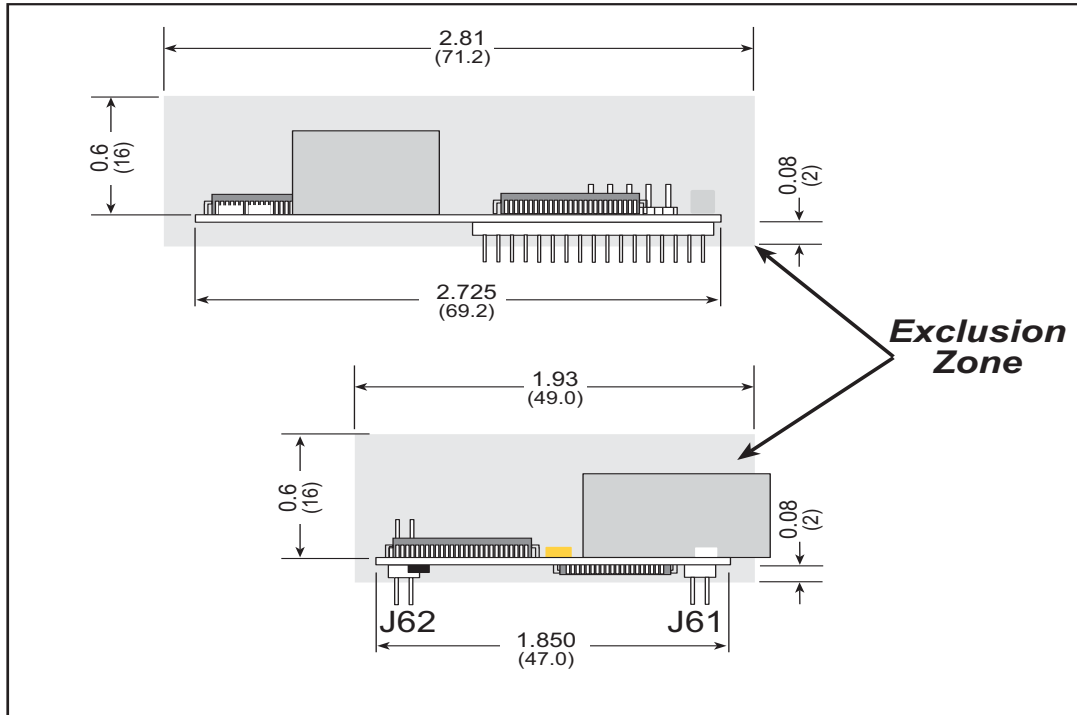

Figure A-2. RCM3900 “Exclusion Zone”

Table A-1 lists the electrical, mechanical, and environmental specifications for the RCM3900.

Table A-1. RabbitCore RCM3900 Specifications

Parameter	RCM3900	RCM3910
Microprocessor	Low-EMI Rabbit® 3000 at 44.2 MHz	
EMI Reduction	Spectrum spreader for reduced EMI (radiated emissions)	
Ethernet Port	10/100Base-T, RJ-45, 3 LEDs	
SRAM	512K program (fast SRAM) + 512K data	
Flash Memory (program)	512K	
Memory (data storage)	32MB (fixed NAND flash) + 128MB–1GB <i>miniSD™ Card</i>	128MB–1GB <i>miniSD™ Card</i>
LED Indicators	LINK/ACT (link/activity) FDX/COL (full-duplex/collisions) SPEED (on for 100Base-T Ethernet connection) CE/BSY (not used/user-programmable)	
Backup Battery	Connection for user-supplied backup battery (to support RTC and data SRAM)	
General-Purpose I/O	52 parallel digital I/O lines: <ul style="list-style-type: none"> • 44 configurable I/O • 4 fixed inputs • 4 fixed outputs 	
Additional Inputs	Startup mode (2), reset in	
Additional Outputs	Status, reset out	
External I/O Bus	Can be configured for 8 data lines and 5 address lines (shared with parallel I/O lines), plus I/O read/write	
Serial Ports	Five 3.3 V, CMOS-compatible ports (shared with I/O) <ul style="list-style-type: none"> • all 5 configurable as asynchronous (with IrDA) • 3 configurable as clocked serial (SPI) • 2 configurable as SDLC/HDLC • 1 asynchronous serial port dedicated for programming 	
Serial Rate	Maximum asynchronous baud rate = CLK/8	
Slave Interface	A slave port allows the RCM3900/RCM3910 to be used as an intelligent peripheral device slaved to a master processor, which may either be another Rabbit 3000 or any other type of processor	
Real-Time Clock	Yes	
Timers	Ten 8-bit timers (6 cascadable, 3 reserved for internal peripherals), one 10-bit timer with 2 match registers	
Watchdog/Supervisor	Yes	
Pulse-Width Modulators	4 PWM registers with 10-bit free-running counter and priority interrupts	

Table A-1. RabbitCore RCM3900 Specifications (continued)

Parameter	RCM3900	RCM3910
Input Capture	2-channel input capture can be used to time input signals from various port pins	
Quadrature Decoder	2-channel quadrature decoder accepts inputs from external incremental encoder modules	
Power	3.15–3.45 V DC 325 mA @ 44.2 MHz, 3.3 V	
Operating Temperature	-20°C to +85°C	
Humidity	5% to 95%, noncondensing	
Connectors	Two 2 × 17, 2 mm pitch One 2 × 5 for programming with 1.27 mm pitch One <i>miniSD</i> [™] Card socket	
Board Size	1.850" × 2.725" × 0.86" (47 mm × 69 mm × 22 mm)	

A.1.1 Headers

The RCM3900 uses headers at J61 and J62 for physical connection to other boards. J61 and J62 are 2×17 SMT headers with a 2 mm pin spacing. J1, the programming port, is a 2×5 header with a 1.27 mm pin spacing.

Figure A-3 shows the layout of another board for the RCM3900 to be plugged into. These values are relative to the mounting hole.

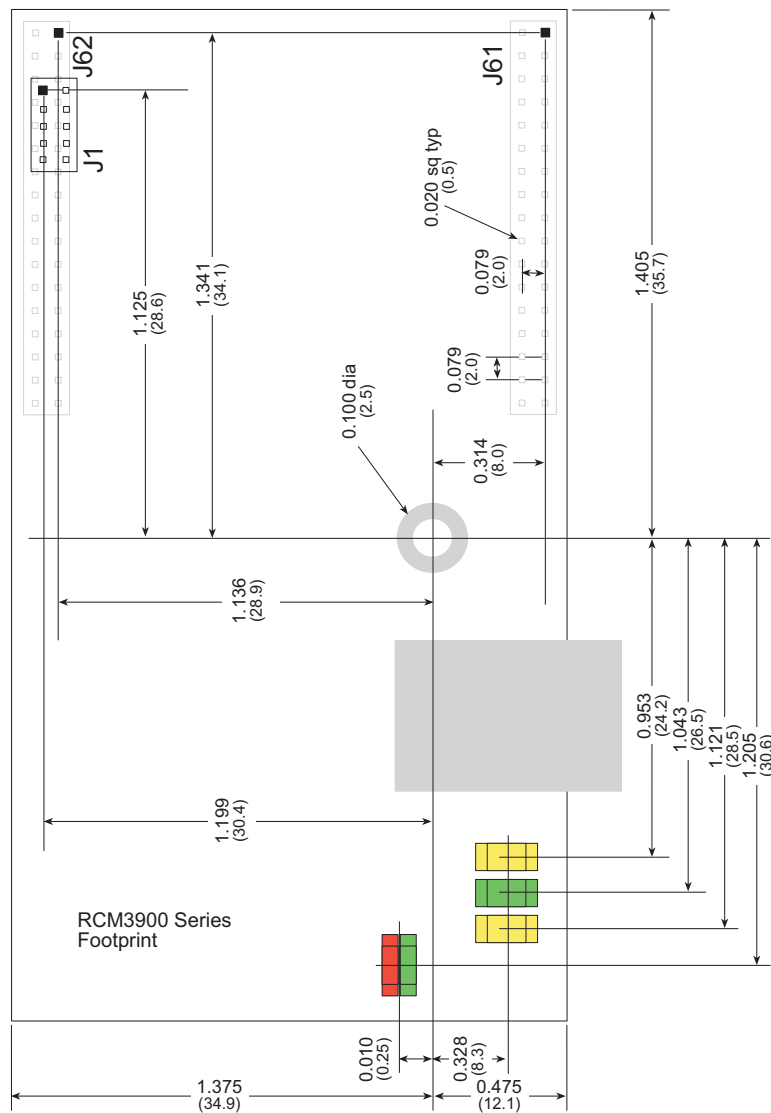

Figure A-3. User Board Footprint for RCM3900

A.2 Bus Loading

You must pay careful attention to bus loading when designing an interface to the RCM3900. This section provides bus loading information for external devices.

Table A-2 lists the capacitance for the various RCM3900 I/O ports.

Table A-2. Capacitance of Rabbit 3000 I/O Ports

I/O Ports	Input Capacitance (pF)	Output Capacitance (pF)
Parallel Ports A to G	12	14

Table A-3 lists the external capacitive bus loading for the various RCM3900 output ports. Be sure to add the loads for the devices you are using in your custom system and verify that they do not exceed the values in Table A-3.

Table A-3. External Capacitive Bus Loading -40°C to +85°C

Output Port	Clock Speed (MHz)	Maximum External Capacitive Loading (pF)
All I/O lines with clock doubler enabled	22.1	100

Figure A-4 shows a typical timing diagram for the Rabbit 3000 microprocessor external I/O read and write cycles.

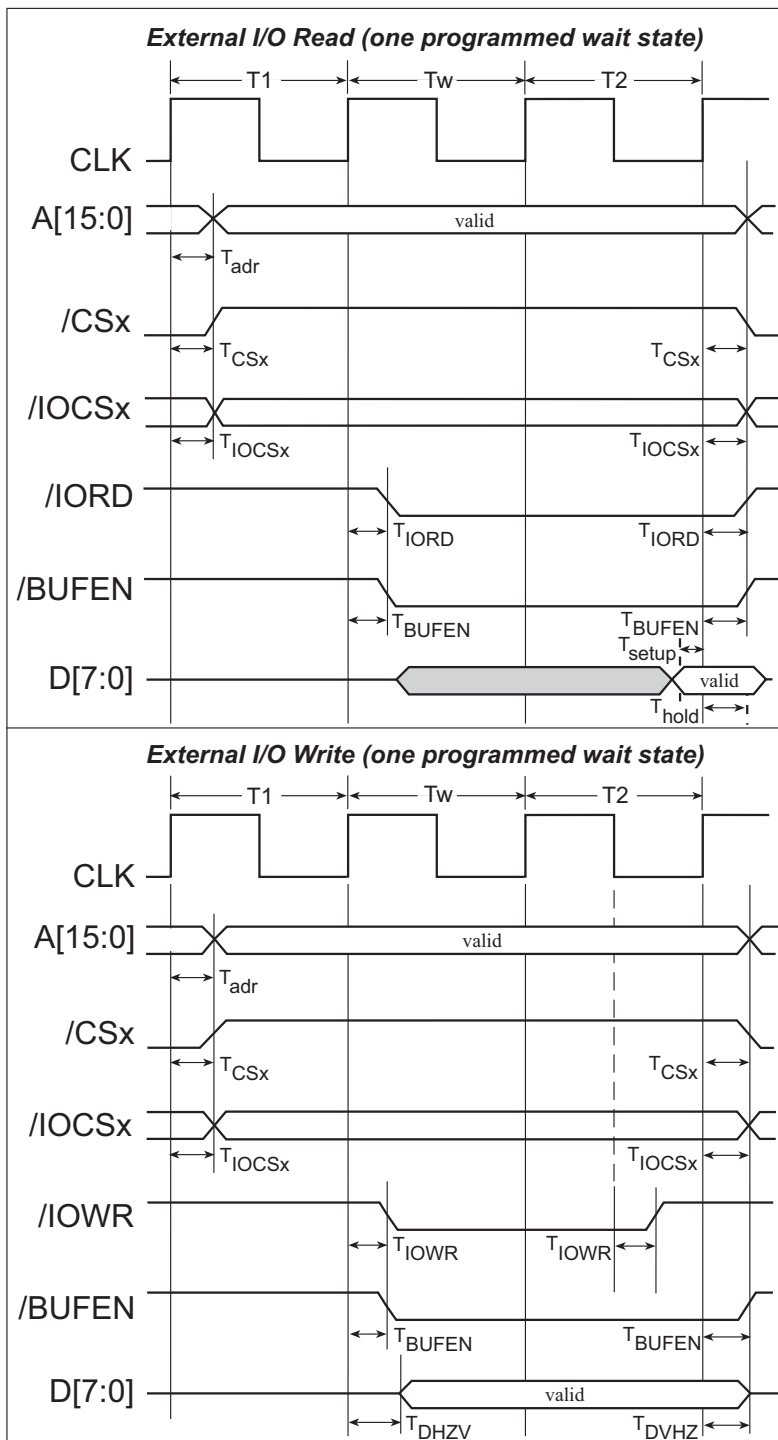

Figure A-4. I/O Read and Write Cycles—No Extra Wait States

NOTE: /IOCSx can be programmed to be active low (default) or active high.

Table A-4 lists the delays in gross memory access time.

Table A-4. Data and Clock Delays $V_{IN} \pm 10\%$, Temp, -40°C – $+85^{\circ}\text{C}$ (maximum)

VIN	Clock to Address Output Delay (ns)			Data Setup Time Delay (ns)	Spectrum Spreader Delay (ns)	
	30 pF	60 pF	90 pF		Normal no dbl/dbl	Strong no dbl/dbl
3.3 V	6	8	11	1	3/4.5	4.5/9

The measurements are taken at the 50% points under the following conditions.

- $T = -40^{\circ}\text{C}$ to 85°C , $V = V_{DD} \pm 10\%$
- Internal clock to nonloaded CLK pin delay ≤ 1 ns @ $85^{\circ}\text{C}/3.0$ V

The clock to address output delays are similar, and apply to the following delays.

- T_{adr} , the clock to address delay
- T_{CSx} , the clock to memory chip select delay
- T_{IOCSx} , the clock to I/O chip select delay
- T_{IORD} , the clock to I/O read strobe delay
- T_{IOWR} , the clock to I/O write strobe delay
- T_{BUFEN} , the clock to I/O buffer enable delay

The data setup time delays are similar for both T_{setup} and T_{hold} .

When the spectrum spreader is enabled with the clock doubler, every other clock cycle is shortened (sometimes lengthened) by a maximum amount given in the table above. The shortening takes place by shortening the high part of the clock. If the doubler is not enabled, then every clock is shortened during the low part of the clock period. The maximum shortening for a pair of clocks combined is shown in the table.

Technical Note TN227, *Interfacing External I/O with Rabbit 2000/3000 Designs*, contains suggestions for interfacing I/O devices to the Rabbit 3000 microprocessors.

A.3 Rabbit 3000 DC Characteristics

Table A-5. Rabbit 3000 Absolute Maximum Ratings

Symbol	Parameter	Maximum Rating
T_A	Operating Temperature	-55° to +85°C
T_S	Storage Temperature	-65° to +150°C
	Maximum Input Voltage: <ul style="list-style-type: none"> • Oscillator Buffer Input • 5-V-tolerant I/O 	$V_{DD} + 0.5\text{ V}$ 5.5 V
V_{DD}	Maximum Operating Voltage	3.6 V

Stresses beyond those listed in Table A-5 may cause permanent damage. The ratings are stress ratings only, and functional operation of the Rabbit 3000 chip at these or any other conditions beyond those indicated in this section is not implied. Exposure to the absolute maximum rating conditions for extended periods may affect the reliability of the Rabbit 3000 chip.

Table A-6 outlines the DC characteristics for the Rabbit 3000 at 3.3 V over the recommended operating temperature range from $T_A = -55^\circ\text{C}$ to $+85^\circ\text{C}$, $V_{DD} = 3.0\text{ V}$ to 3.6 V .

Table A-6. 3.3 Volt DC Characteristics

Symbol	Parameter	Test Conditions	Min	Typ	Max	Units
V_{DD}	Supply Voltage		3.0	3.3	3.6	V
V_{IH}	High-Level Input Voltage		2.0			V
V_{IL}	Low-Level Input Voltage				0.8	V
V_{OH}	High-Level Output Voltage	$I_{OH} = 6.8\text{ mA}$, $V_{DD} = V_{DD}(\text{min})$	$0.7 \times V_{DD}$			V
V_{OL}	Low-Level Output Voltage	$I_{OL} = 6.8\text{ mA}$, $V_{DD} = V_{DD}(\text{min})$			0.4	V
I_{IH}	High-Level Input Current (absolute worst case, all buffers)	$V_{IN} = V_{DD}$, $V_{DD} = V_{DD}(\text{max})$			10	μA
I_{IL}	Low-Level Input Current (absolute worst case, all buffers)	$V_{IN} = V_{SS}$, $V_{DD} = V_{DD}(\text{max})$	-10			μA
I_{OZ}	High-Impedance State Output Current (absolute worst case, all buffers)	$V_{IN} = V_{DD}$ or V_{SS} , $V_{DD} = V_{DD}(\text{max})$, no pull-up	-10		10	μA

A.4 I/O Buffer Sourcing and Sinking Limit

Unless otherwise specified, the Rabbit I/O buffers are capable of sourcing and sinking 6.8 mA of current per pin at full AC switching speed. Full AC switching assumes a 22.1 MHz CPU clock and capacitive loading on address and data lines of less than 100 pF per pin. The absolute maximum operating voltage on all I/O is 5.5 V.

Table A-7 shows the AC and DC output drive limits of the parallel I/O buffers when the Rabbit 3000 is used in the RCM3900.

Table A-7. I/O Buffer Sourcing and Sinking Capability

Pin Name	Output Drive (Full AC Switching) Sourcing/Sinking Limits (mA)	
	Sourcing	Sinking
All data, address, and I/O lines with clock doubler enabled	6.8	6.8

Under certain conditions, you can exceed the limits outlined in Table A-7. See the *Rabbit 3000 Microprocessor User's Manual* for additional information.

A.5 Conformal Coating

The areas around the 32 kHz real-time clock crystal oscillator have had the Dow Corning silicone-based 1-2620 conformal coating applied. The conformally coated area is shown in Figure A-5. The conformal coating protects these high-impedance circuits from the effects of moisture and contaminants over time.

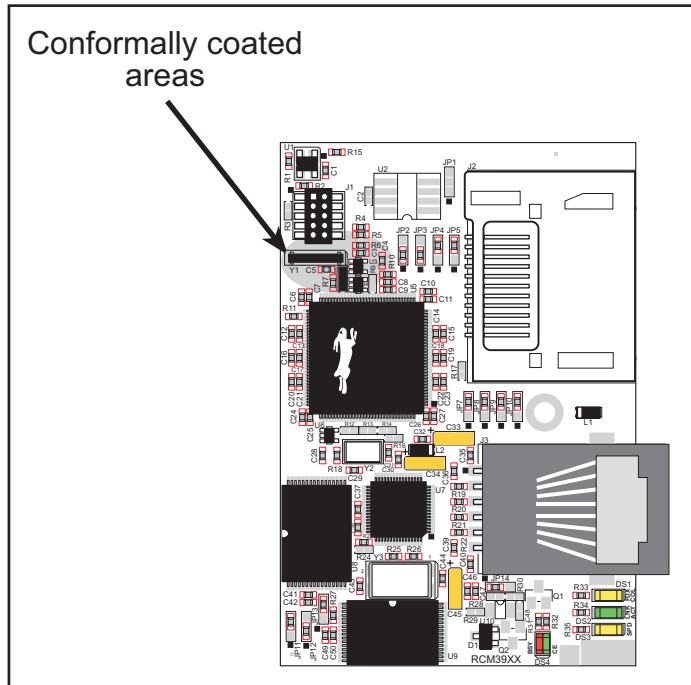

Figure A-5. RCM3900 Areas Receiving Conformal Coating

Any components in the conformally coated area may be replaced using standard soldering procedures for surface-mounted components. A new conformal coating should then be applied to offer continuing protection against the effects of moisture and contaminants.

NOTE: For more information on conformal coatings, refer to Rabbit's Technical Note 303, *Conformal Coatings* in the online document suite.

A.6 Jumper Configurations

Figure A-6 shows the header locations used to configure the various RCM3900 options via jumpers.

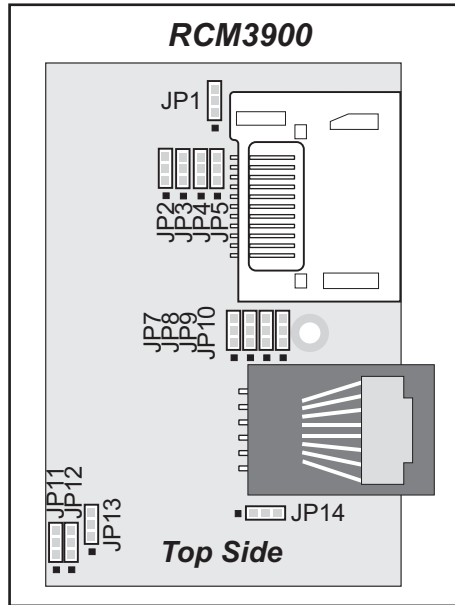

Figure A-6. Location of RCM3900 Configurable Positions

Table A-8 lists the configuration options.

Table A-8. RCM3900 Jumper Configurations

Header	Description	Pins Connected		Factory Default
JP1	Serial Flash Chip Enable Indicator	1-2		n.c.
JP2	ACT or PD1 Output on J61 pin 34	1-2	ACT	×
		2-3	PD1	
JP3	LINK or PD0 Output on J61 pin 33	1-2	LINK	×
		2-3	PD0	
JP4	ENET or PE0 Output on J62 pin 19	1-2	ENET	
		2-3	PE0	×
JP5	NAND Flash Chip Enable	1-2	Reserved for future use	
		2-3	PD1 controls NAND Flash	RCM3900 only

Table A-8. RCM3900 Jumper Configurations

Header	Description	Pins Connected		Factory Default
JP7	PD6 or TPI- Input on J61 pin 31	1-2	TPI-	
		2-3	PD6	×
JP8	PD7 or TPI+ Input on J61 pin 32	1-2	TPI+	
		2-3	PD7	×
JP9	PD2 or TPO- Output on J61 pin 29	1-2	TPO-	n.c.
		2-3	PD2	
JP10	PD3 or TPO+ Output on J61 pin 30	1-2	TPO+	
		2-3	PD3	×
JP11	Flash Memory Size	1-2	256K	
		2-3	512K	×
JP12	Flash Memory Bank Select	1-2	Normal Mode	×
		2-3	Bank Mode	
JP13	Data SRAM Size	1-2	256K	
		2-3	512K	×
JP14	LED DS1 Display	1-2	FDX/COL displayed by LED DS1	×
		2-3	Optional ACT displayed by LED DS1	

NOTE: The jumper connections are made using 0 Ω surface-mounted resistors.



APPENDIX B. PROTOTYPING BOARD

Appendix B describes the features and accessories of the Prototyping Board.

B.1 Introduction

The Prototyping Board included in the Development Kit makes it easy to connect an RCM3900 module to a power supply and a PC workstation for development. It also provides some basic I/O peripherals (RS-232, RS-485, a relay, LEDs, and switches), as well as a prototyping area for more advanced hardware development.

For the most basic level of evaluation and development, the Prototyping Board can be used without modification.

As you progress to more sophisticated experimentation and hardware development, modifications and additions can be made to the board without modifying or damaging the RCM3900 module itself.

The Prototyping Board is shown below in Figure B-1, with its main features identified.

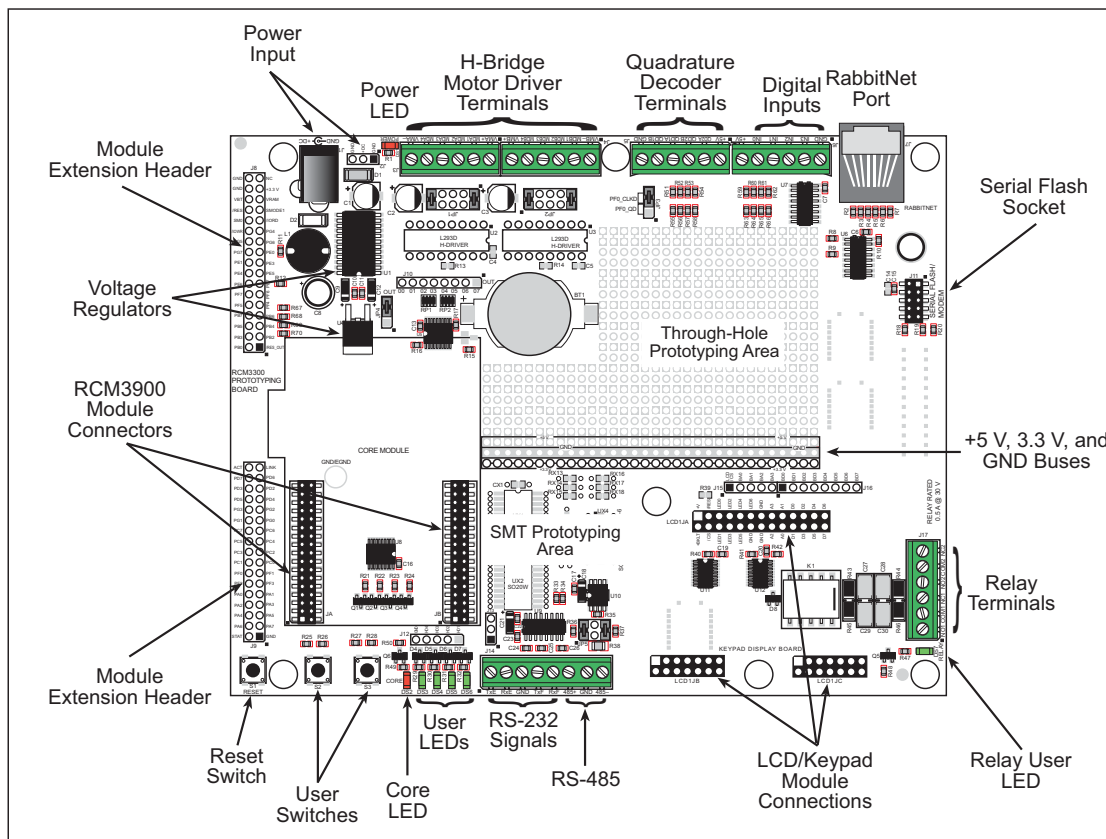

Figure B-1. Prototyping Board

B.1.1 Prototyping Board Features

- **Power Connection**—A power-supply jack and a 3-pin header are provided for connection to the power supply. Note that the 3-pin header is symmetrical, with both outer pins connected to ground and the center pin connected to the raw V+ input. The cable of the AC adapter provided with Development Kit ends in a 3-pin plug that connects to the 3-pin header (J2)—the center pin of J2 is always connected to the positive terminal, and either edge pin is negative.

Users providing their own power supply should ensure that it delivers 8–30 V DC at 1 A.

- **Regulated Power Supply**—The raw DC voltage provided at the POWER IN jack is routed to a 5 V switching voltage regulator, then to a separate 3.3 V linear regulator. The regulators provide stable power to the RCM3900 module and the Prototyping Board. The voltage regulators will get warm while in use.
- **Power LED**—The power LED lights whenever power is connected to the Prototyping Board.
- **Core LED**—The core LED lights whenever an RCM3900 module is plugged in correctly on the Prototyping Board and the RCM3900 module is not being reset.
- **Relay LED**—The relay LED lights whenever the Prototyping Board relay is energized.
- **Reset Switch**—A momentary-contact, normally open switch is connected directly to the RCM3900's /RESET_IN pin. Pressing the switch forces a hardware reset of the system.
- **I/O Switches and LEDs**—Two momentary-contact, normally open switches are connected to the PG0 and PG1 pins of the RCM3900 module and may be read as inputs by sample applications.

Four user LEDs (DS3–DS6) are connected to alternate I/O bus pins PA0–PA3 pins of the RCM3900 module via U8, and may be driven as output indicators. PE7 and PG5 control the registers in U8 as shown in the sample applications.

- **Prototyping Area**—A generous prototyping area has been provided for the installation of through-hole components. +3.3 V, +5 V, and Ground buses run along one edge of this area. Several areas for surface-mount devices are also available. Each SMT pad is connected to a hole designed to accept a 30 AWG solid wire.
- **LCD/Keypad Module**—Rabbit's LCD/keypad module may be plugged in directly to headers LCD1JA, LCD1JB, and LCD1JC. The signals on headers LCD1JB and LCD1JC will be available only if the LCD/keypad module is plugged in to header LCD1JA. Appendix C provides complete information for mounting and using the LCD/keypad module.

- **Module Extension Headers**—The complete pin set of the RCM3900 module is duplicated at headers J8 and J9. Developers can solder wires directly into the appropriate holes, or, for more flexible development, 2×17 header strips with a 0.1" pitch can be soldered into place. See Figure B-4 for the header pinouts.
- **Digital I/O**—Four digital inputs are available on screw-terminal header J6. See Figure B-4 for the header pinouts.
- **RS-232**—Two 3-wire serial ports or one 5-wire RS-232 serial port are available on the Prototyping Board at screw-terminal header J14.
- **RS-485**—One RS-485 serial port is available on the Prototyping Board at screw-terminal header J14.
- **Quadrature Decoder**—Four quadrature decoder inputs (PF0–PF3) from the Rabbit 3000 chip are available on screw-terminal header J5. See Figure B-4 for the header pinouts.
- **H-Bridge Motor Driver**—Two pairs of H-bridge motor drivers are supported using screw-terminal headers J3 and J4 on the Prototyping Board for stepper-motor control. See Figure B-4 for the header pinouts.
- **RabbitNet Port**—One RS-422 RabbitNet port (shared with the serial flash interface) is available to allow RabbitNet peripheral cards to be used with the Prototyping Board. The Prototyping Board cannot be used with RabbitNet peripheral cards when the RCM3900/RCM3910 is installed.
- **Serial Flash Interface**—One serial flash interface (shared with the RabbitNet port) is available to allow Rabbit’s SF1000 series serial flash to be used on the Prototyping Board. The Prototyping Board cannot be used with the SF1000 series of serial flash memories when the RCM3900/RCM3910 is installed.

B.2 Mechanical Dimensions and Layout

Figure B-2 shows the mechanical dimensions and layout for the Prototyping Board.

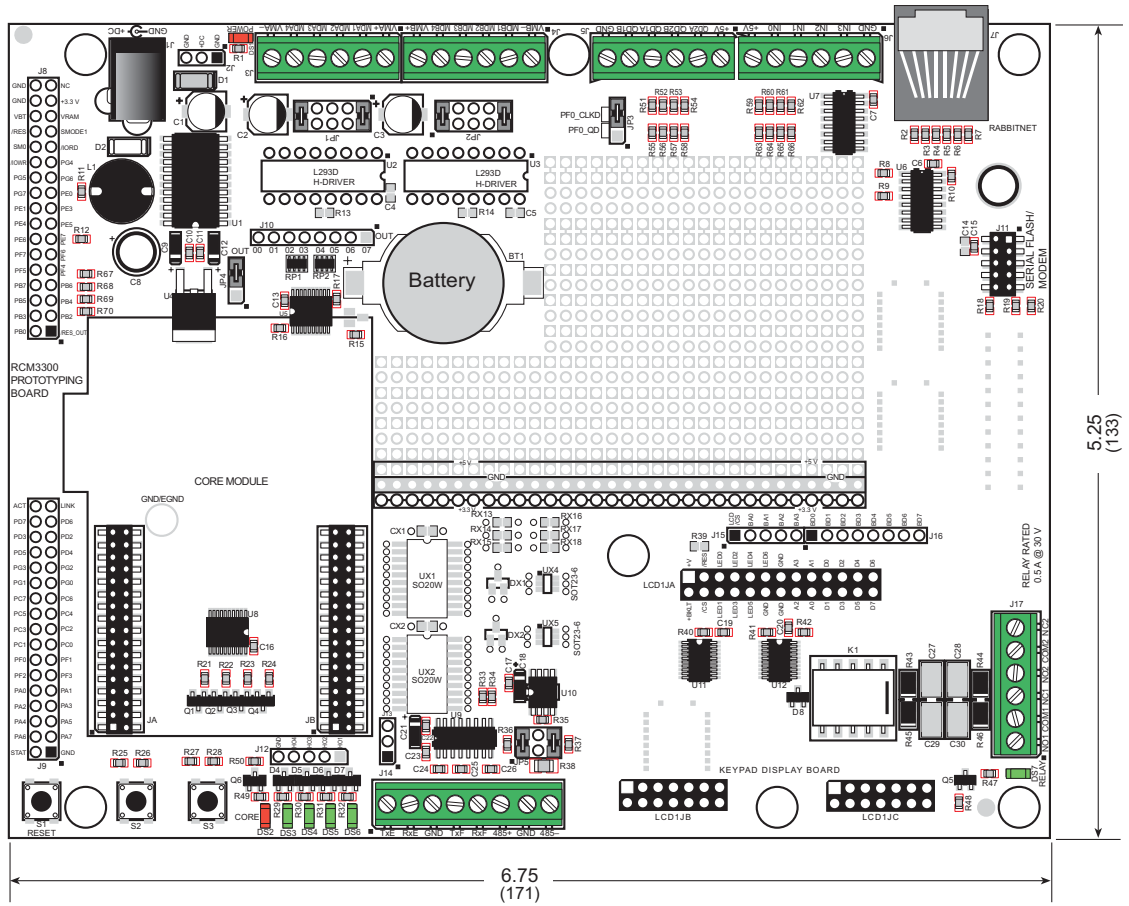

Figure B-2. Prototyping Board Dimensions

NOTE: All measurements are in inches followed by millimeters enclosed in parentheses.

Table B-1 lists the electrical, mechanical, and environmental specifications for the Prototyping Board.

Table B-1. Prototyping Board Specifications

Parameter	Specification
Board Size	5.25" × 6.75" × 1.00" (133 mm × 171 mm × 25 mm)
Operating Temperature	−20°C to +70°C
Humidity	5% to 95%, noncondensing
Input Voltage	8 V to 30 V DC
Maximum Current Draw (including user-added circuits)	800 mA max. for +3.3 V supply, 1 A total +3.3 V and +5 V combined
Backup Battery	CR2032, 3 V lithium coin-type
Digital Inputs	4 inputs pulled up, ± 36 V DC, switching threshold 0.9–2.3 V typical
Digital Outputs	4 sinking outputs, +30 V DC, 500 mA maximum per channel 8 CMOS-level outputs if stepper motor not installed
Relay	SPDT relay, 500 mA @ 30 V
Serial Ports	<ul style="list-style-type: none"> two 3-wire RS-232 <i>or</i> one RS-232 with RTS/CTS one RS-485
Other Serial Interfaces	RabbitNet RS-422 port <i>or</i> serial flash interface*
Other Interfaces	<ul style="list-style-type: none"> stepper motor control quadrature decoder LCD/keypad module
LEDs	Seven LEDs <ul style="list-style-type: none"> one power on indicator one RCM3900 module indicator four user-configurable LEDs one relay indicator
Prototyping Area	Throughhole, 0.1" spacing, additional space for SMT components
Connectors	<ul style="list-style-type: none"> two 2 × 17, 2 mm pitch sockets for RCM3900 module one 2 × 5, 2 mm pitch socket for serial flash* six screw-terminal headers for serial ports, digital inputs, stepper motor control, quadrature decoder, and relay contacts one RJ-45 RabbitNet jack*
Standoffs/Spacers	7, accept 4-40 x 1/2 screws

* This interface is not available when the RCM3900/RCM3910 is installed.

B.3 Power Supply

The RCM3900 requires a regulated 3.15 V to 3.45 V DC power source to operate. Depending on the amount of current required by the application, different regulators can be used to supply this voltage.

The Prototyping Board has an onboard +5 V switching power regulator from which a +3.3 V linear regulator draws its supply. Thus both +5 V and +3.3 V are available on the Prototyping Board.

The Prototyping Board itself is protected against reverse polarity by a diode at D1 as shown in Figure B-3.

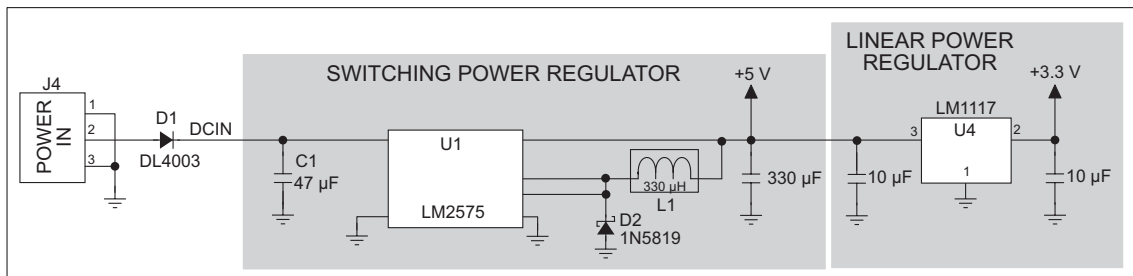

Figure B-3. Prototyping Board Power Supply

B.4 Using the Prototyping Board

The Prototyping Board is actually both a demonstration board and a prototyping board. As a demonstration board, it can be used with the sample programs to demonstrate the functionality of the RCM3900 right out of the box without any modifications.

The Prototyping Board pinouts are shown in Figure B-4.

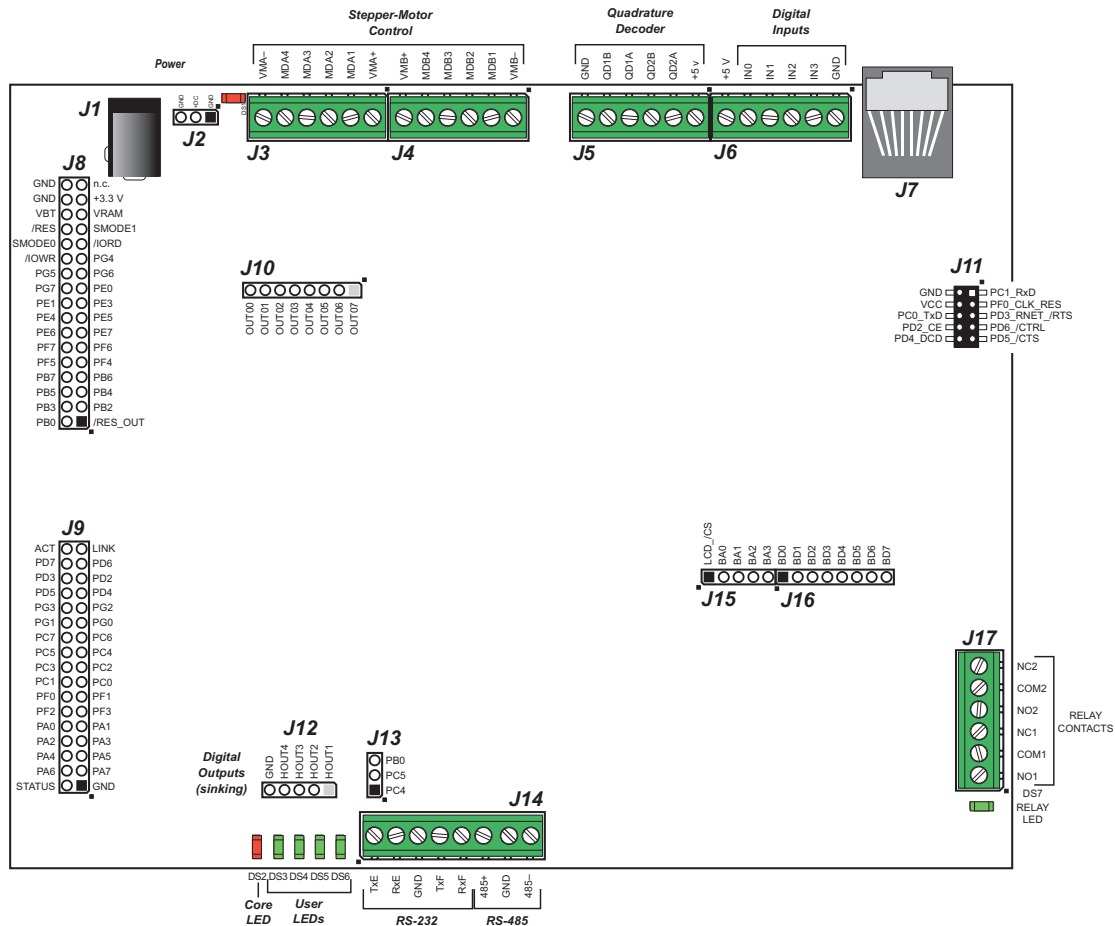

Figure B-4. Prototyping Board Pinout

The Prototyping Board comes with the basic components necessary to demonstrate the operation of the RCM3900. Four user LEDs (DS3–DS6) are connected to alternate I/O bus pins PA0–PA3 pins of the RCM3900 module via U8, and may be driven as output indicators when controlled by PE7 and PG5 as shown in the sample applications. Two switches (S2 and S3) are connected to PG0 and PG1 to demonstrate the interface to the Rabbit 3000 microprocessor. Reset switch S1 is the hardware reset for the RCM3900.

The Prototyping Board provides the user with RCM3900 connection points brought out conveniently to labeled points at J8 and J9 on the Prototyping Board. Although locations J8 and J9 are unstuffed, 2×17 headers are included in the bag of parts.

RS-232 and RS-485 signals are available on screw-terminal header J14, quadrature decoder inputs are available on screw-terminal header J5, and digital inputs are available on screw-terminal header J6. A 1×5 header strip from the bag of parts may be installed at J12 for four sinking digital outputs. The clocked Serial Port B signals from the RCM3900 are used for the *miniSD™ Card*, and cannot be accessed via header J13 on the Prototyping Board.

If you don't plan to use the LCD/keypad module, additional signals may be brought out on 1×5 and 1×8 headers from the bag of parts that you install at J15 and J16. If you don't plan to use the stepper-motor control option, additional CMOS outputs are available via a 1×8 header that you install at J10.

There is a through-hole prototyping space available on the Prototyping Board. The holes in the prototyping area are spaced at 0.1" (2.5 mm). +3.3 V, +5 V, and GND traces run along one edge of the prototyping area. Small to medium circuits can be prototyped using point-to-point wiring with 20 to 30 AWG wire between the prototyping area, the +3.3 V, +5 V, and GND traces, and the surrounding area where surface-mount components may be installed. Small holes are provided around the surface-mounted components that may be installed around the prototyping area.

B.4.1 Adding Other Components

There are two sets of pads for 6-pin, 16-pin, and 28-pin devices that can be used for surface-mount prototyping devices. There are also pads that can be used for SMT resistors and capacitors in an 0805 SMT package. Each component has every one of its pin pads connected to a hole in which a 30 AWG wire can be soldered (standard wire wrap wire can be soldered in for point-to-point wiring on the Prototyping Board). Because the traces are very thin, carefully determine which set of holes is connected to which surface-mount pad.

B.4.2 Digital I/O

B.4.2.1 Digital Inputs

The Prototyping Board has four digital inputs, IN0–IN3, each of which is protected over a range of -36 V to $+36\text{ V}$. The inputs are pulled up to $+3.3\text{ V}$ as shown in Figure B-5.

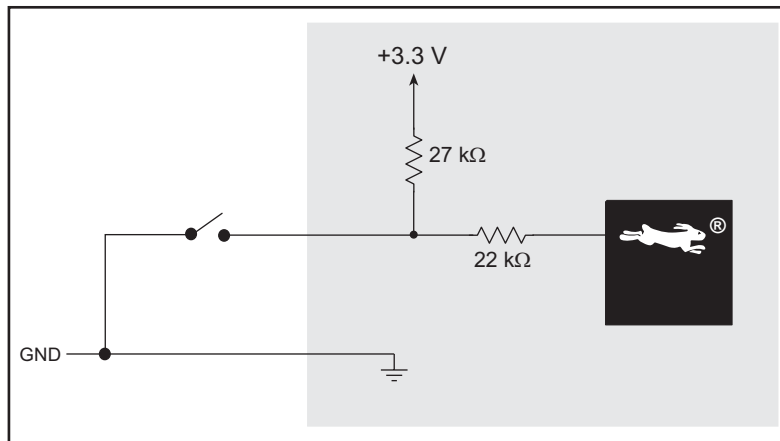

Figure B-5. Prototyping Board Digital Inputs

The four quadrature decoder inputs on screw-terminal header J5 may be used as inputs IN4–IN7. To use the PF0 signal from the Rabbit microprocessor, which goes to QD1B, remember to reconfigure the jumper on header JP3 to jumper pins 1–2.

The actual switching threshold is between 0.9 V and 2.3 V . Anything below this value is a logic 0, and anything above is a logic 1.

The digital inputs are each fully protected over a range of -36 V to $+36\text{ V}$, and can handle short spikes of $\pm 40\text{ V}$.

B.4.3 CMOS Digital Outputs

If the stepper-motor option is not used, eight CMOS-level digital outputs are available at J10, and can each handle up to 25 mA.

B.4.4 Sinking Digital Outputs

Four sinking digital outputs shared with LEDs DS3–DS6 are available at J12, and can each handle up to 500 mA. Figure B-6 shows a wiring diagram for a typical sinking output.

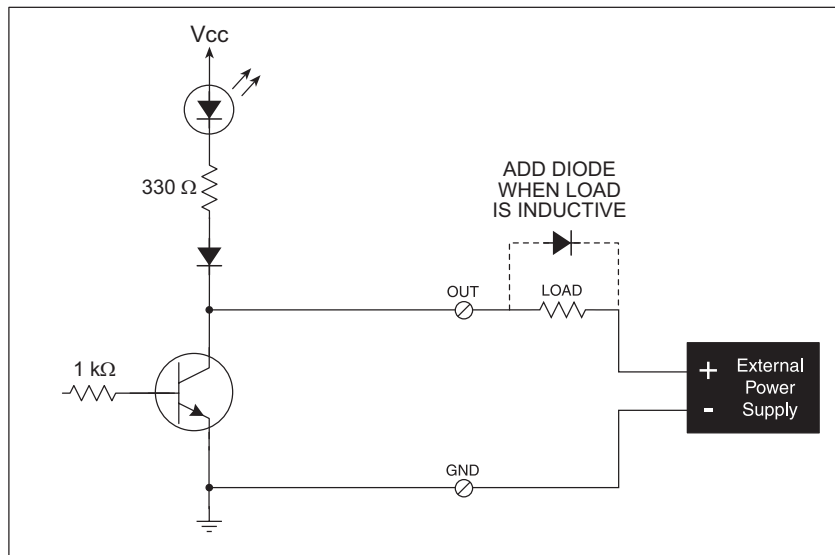

Figure B-6. Prototyping Board Sinking Digital Outputs

B.4.5 Relay Outputs

Figure B-7 shows the contact connections for the relay on the Prototyping Board. A diode across the coil provides a return path for inductive spikes, and snubbers across the relay contacts protect the relay contacts from inductive spikes.

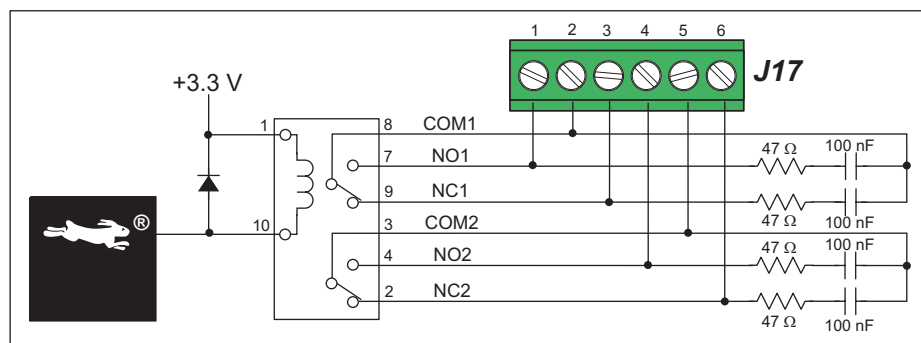

Figure B-7. Prototyping Board Relay Output Contact Connections

The relay is driven by pin PA4 of the RCM3900 module via U8, and is controlled by PE7 and PG5 as shown in the sample applications.

B.4.6 Serial Communication

The Prototyping Board allows you to access up to three of the serial ports from the RCM3900/RCM3910. Table B-2 summarizes the configuration options.

Table B-2. Prototyping Board Serial Port Configurations

Serial Port	Signal Header	Configured via	Default Use	Alternate Use
C	J14	JP5*	RS-485	—
D	J7	JP3	RabbitNet/SF1000 interface†	Rabbit 3000 quadrature decoder
	J11			
E	J14	—	RS-232	—
F	J14	—	RS-232	—

* RS-485 termination and bias resistors are configured via header JP5.

† This interface is not available when the RCM3900/RCM3910 is installed.

Ordinarily, Serial Port D must be configured either to allow J7 to be used as a RabbitNet port or to allow J11 to be used as a serial interface for the SF1000 series serial flash. When other RabbitCore modules supplied with this Prototyping Board in their Development Kit are plugged into the Prototyping Board, PD2 is configured in software to enable the RS-422 transceiver for the RabbitNet SPI interface. PD2 is not brought out from the RCM3900/RCM3910. Serial Port D may be used as a serial port via the Prototyping Board when the RCM3900/RCM3910 is installed with PC0 and PC1 to a serial transceiver of your own in the prototyping area.

B.4.6.1 RS-232

RS-232 serial communication on the Prototyping Board is supported by an RS-232 transceiver installed at U9. This transceiver provides the voltage output, slew rate, and input voltage immunity required to meet the RS-232 serial communication protocol. Basically, the chip translates the Rabbit 3000's signals to RS-232 signal levels. Note that the polarity is reversed in an RS-232 circuit so that a +5 V output becomes approximately -10 V and 0 V is output as +10 V. The RS-232 transceiver also provides the proper line loading for reliable communication.

RS-232 can be used effectively at the RCM3900 module's maximum baud rate for distances of up to 15 m.

RS-232 flow control on an RS-232 port is initiated in software using the `serXflowcontrolOn()` function call from the `LIB\RS232.LIB`, where `X` is the serial port (E or F). The locations of the flow control lines are specified using a set of five macros.

`SERX_RTS_PORT`—Data register for the parallel port that the RTS line is on (e.g., PGDR).
`SERX_RTS_SHADOW`—Shadow register for the RTS line's parallel port (e.g., PGDRShadow).
`SERX_RTS_BIT`—The bit number for the RTS line.
`SERX_CTS_PORT`—Data register for the parallel port that the CTS line is on (e.g., PCDRShadow).
`SERX_CTS_BIT`—The bit number for the CTS line.

Standard 3-wire RS-232 communication using Serial Ports E and F is illustrated in the following sample code.

```
#define EINBUFSIZE 15 // set size of circular buffers in bytes
#define EOUTBUFSIZE 15
#define FINBUFSIZE 15
#define FOUTBUFSIZE 15
#define MYBAUD 115200 // set baud rate
#endif
main(){
    serEopen(_MYBAUD); // open Serial Ports E and F
    serFopen(_MYBAUD);
    serEwrFlush(); // flush their input and transmit buffers
    serErdfFlush();
    serFwrFlush();
    serFrdFlush();
    serEclose(_MYBAUD); // close Serial Ports C and D
    serFclose(_MYBAUD);
}
```

B.4.6.2 RS-485

The Prototyping Board has one RS-485 serial channel, which is connected to the Rabbit 3000 Serial Port C through an RS-485 transceiver. The half-duplex communication uses an output from PD7 on the Rabbit 3000 to control the transmit enable on the communication line. Using this scheme a strict master/slave relationship must exist between devices to insure that no two devices attempt to drive the bus simultaneously.

Serial Port C is configured in software for RS-485 as follows.

```
#define ser485open serCopen
#define ser485close serCclose
#define ser485wrFlush serCwrFlush
#define ser485rdFlush serCrdFlush
#define ser485putc serCputc
#define ser485getc serCgetc

#define CINBUFSIZE 15
#define COUTBUFSIZE 15

#ifndef _485BAUD
#define _485BAUD 115200
#endif
#endif
```

The configuration shown above is based on circular buffers. RS-485 configuration may also be done using functions from the `LIB\PACKET.LIB` library.

The Prototyping Boards with RCM3900 modules installed can be used in an RS-485 multidrop network spanning up to 1200 m (4000 ft), and there can be as many as 32 attached devices. Connect the 485+ to 485+ and 485- to 485- using single twisted-pair wires as shown in Figure B-8. Note that a common ground is recommended.

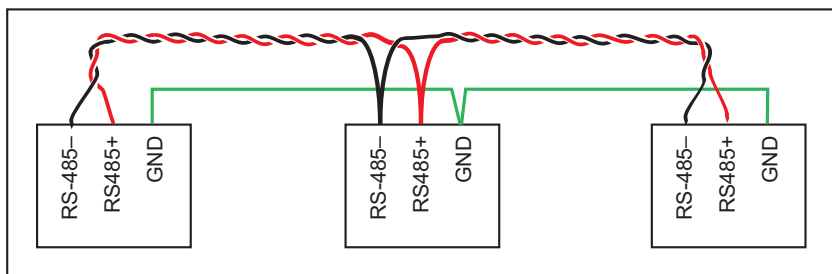

Figure B-8. Multidrop Network

The Prototyping Board comes with a 220 Ω termination resistor and two 681 Ω bias resistors installed and enabled with jumpers across pins 1–2 and 5–6 on header JP5, as shown in Figure B-9.

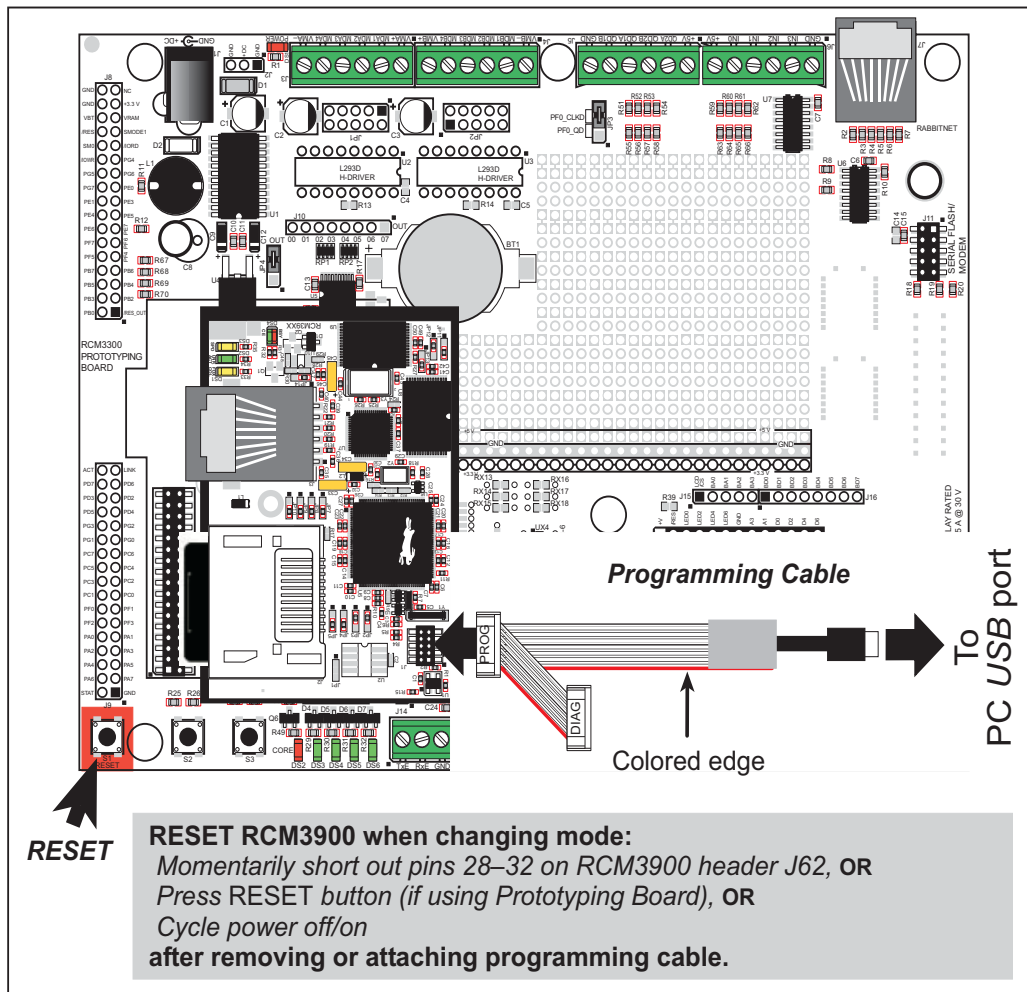

Figure B-9. RS-485 Termination and Bias Resistors

For best performance, the termination resistors in a multidrop network should be enabled only on the end nodes of the network, but *not* on the intervening nodes. Jumpers on boards whose termination resistors are not enabled may be stored across pins 1–3 and 4–6 of header JP5.

B.4.7 RabbitNet Port

The RJ-45 jack labeled *RabbitNet* is a clocked SPI RS-422 serial I/O expansion port for use with RabbitNet peripheral boards. The RabbitNet port is unavailable when an RCM3900/RCM3910 is in place on the Prototyping Board.

B.4.8 Other Prototyping Board Modules

An optional LCD/keypad module is available that can be mounted on the Prototyping Board. The signals on headers LCD1JB and LCD1JC will be available only if the LCD/keypad module is installed. Refer to Appendix C, “LCD/Keypad Module,” for complete information.

B.4.9 Quadrature Decoder

Four quadrature decoder inputs are available on screw-terminal header J5. To use the PF0 input from the Rabbit microprocessor, which goes to the QD1B input, remember to reconfigure the jumper on header JP3 to jumper pins 1–2.

Additional information on the use of the quadrature decoders on Parallel Port F is provided in the *Rabbit 3000 Microprocessor User’s Manual*.

B.4.10 Stepper-Motor Control

The Prototyping Board can be used to demonstrate the use of the RCM3900 to control a stepper motor. Stepper motor control typically directs moves in two orthogonal directions, and so two sets of stepper-motor control circuits are provided for via screw-terminal headers J3 and J4.

In order to use the stepper-motor control, install two Texas Instruments L293DN chips at locations U2 and U3 (shown in Figure B-10). These chips are readily available from your favorite electronics parts source, and may be purchased through our [Web store](#) as part number 660-0205.

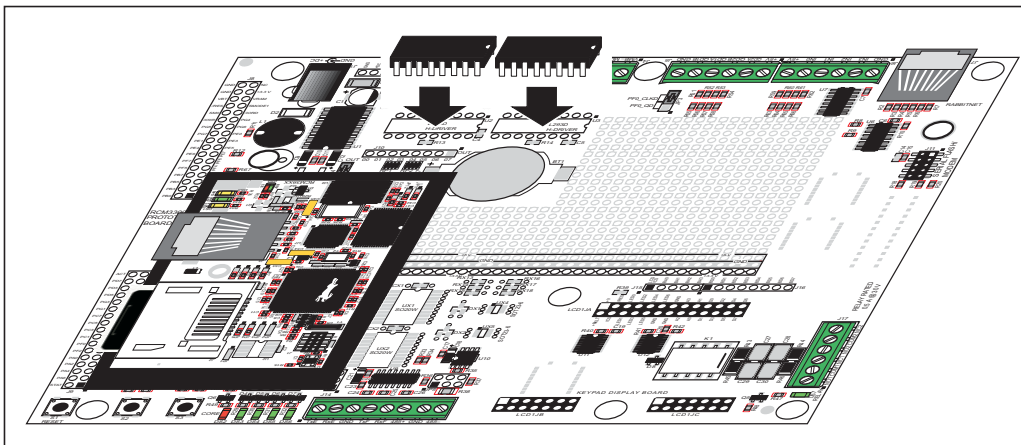

Figure B-10. Install Four-Channel Push-Pull Driver Chips

Figure B-11 shows the stepper-motor driver circuit.

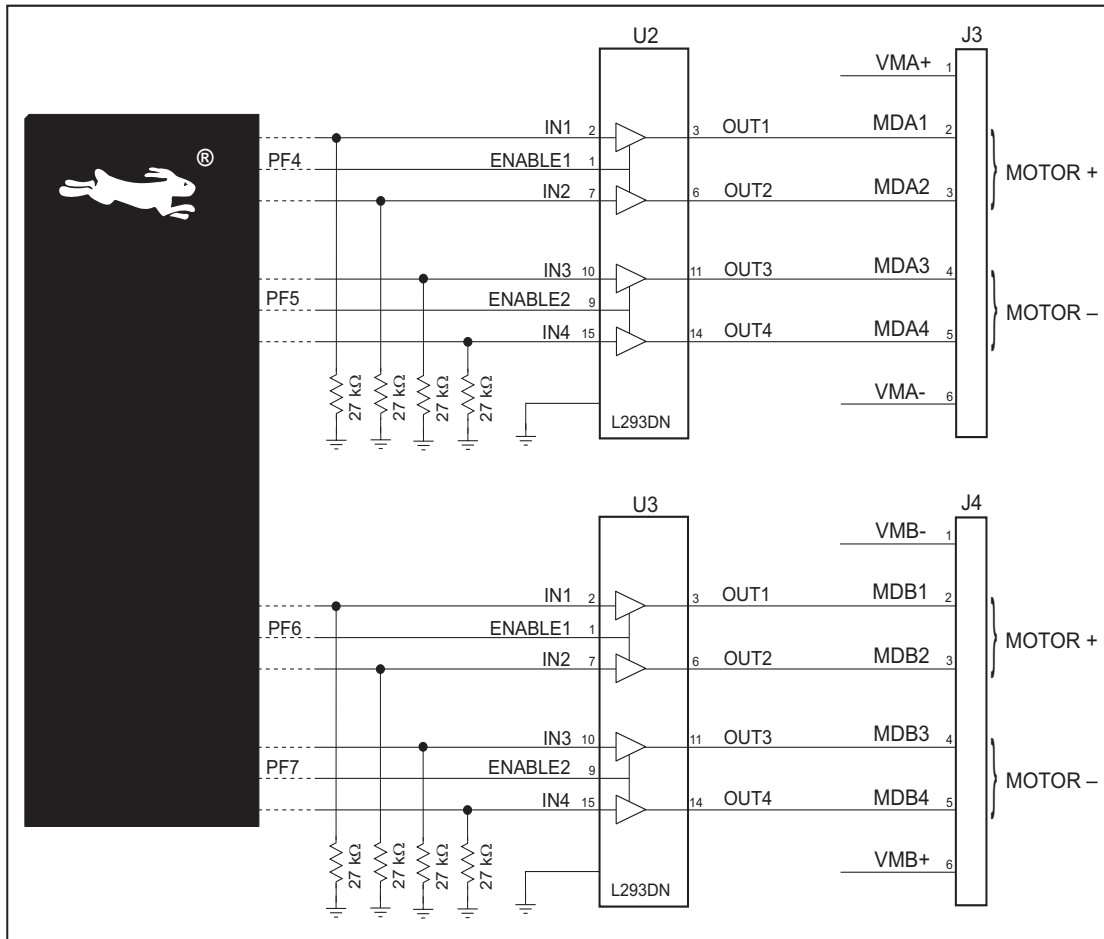

Figure B-11. Stepper-Motor Driver Circuit

The stepper motor(s) can be powered either from the onboard power supply or from an external power based on the jumper settings on headers JP1 and JP2.

Table B-3. Stepper Motor Power-Supply Options

Header	Pins Connected		Factory Default
JP1	1-2 9-10	Onboard power supply to U2	✗
	3-4 7-8	External power supply to U2	
JP2	1-2 9-10	Onboard power supply to U3	✗
	3-4 7-8	External power supply to U3	

B.5 Prototyping Board Jumper Configurations

Figure B-12 shows the header locations used to configure the various Prototyping Board options via jumpers.

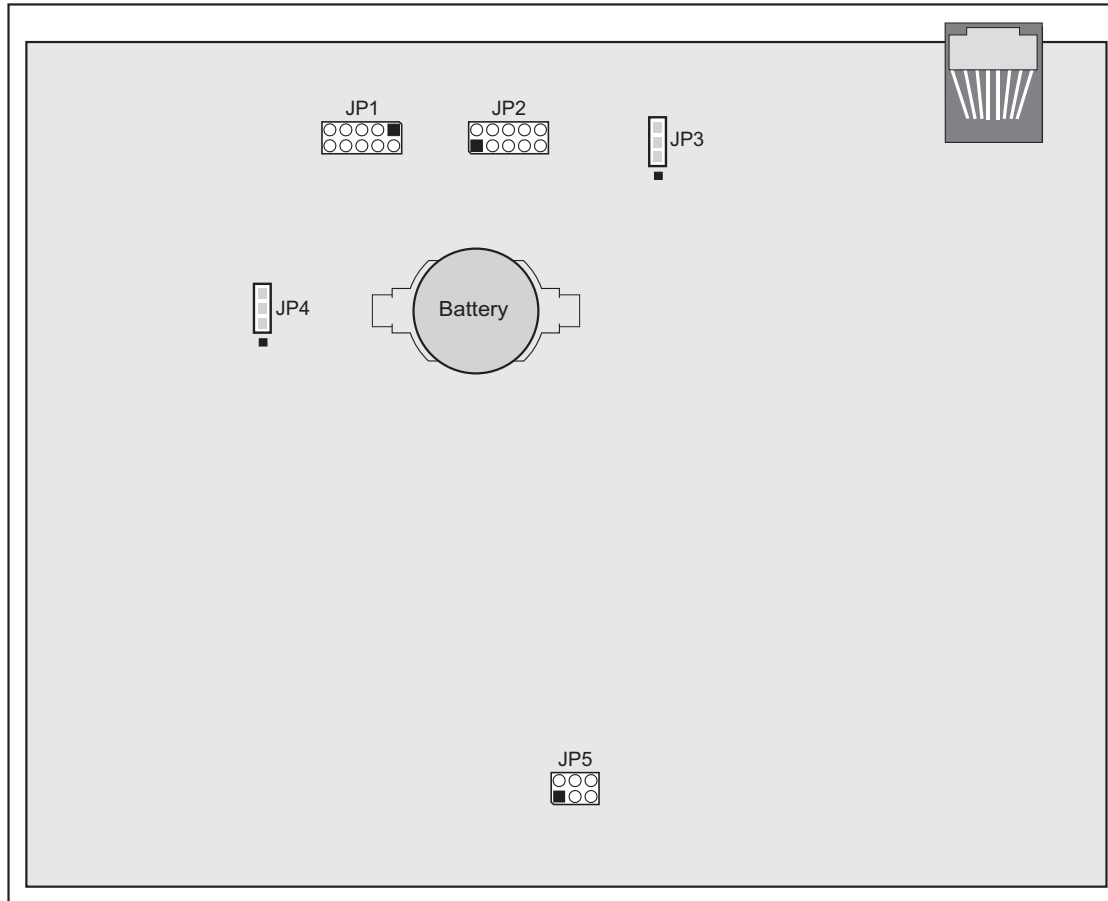

Figure B-12. Location of Prototyping Board Configurable Positions

Table B-4 lists the configuration options using jumpers.

Table B-4. Prototyping Board Jumper Configurations

Header	Description	Pins Connected		Factory Default
JP1	Stepper Motor Power-Supply Options (U2)	1-2 9-10	Onboard power supply	×
		3-4 7-8	External power supply	
JP2	Stepper Motor Power-Supply Options (U3)	1-2 9-10	Onboard power supply	×
		3-4 7-8	External power supply	
JP3	PF0 Option	1-2	Quadrature decoder inputs enabled	
		2-3	RabbitNet/Serial Flash interface enabled	×
JP4	RCM3900 Power Supply	2-3	RCM3900 powered via Prototyping Board	×
JP5	RS-485 Bias and Termination Resistors	1-2 5-6	Bias and termination resistors connected	×
		1-3 4-6	Bias and termination resistors <i>not</i> connected (parking position for jumpers)	

B.6 Use of Rabbit 3000 Parallel Ports

Table B-5 lists the Rabbit 3000 parallel ports and their use for the Prototyping Board.

Table B-5. Prototyping Board Use of Rabbit 3000 Parallel Ports

Port	I/O	Use	Initial State
PA0–PA3	Data Bus	LCD/keypad module, motor driver, LEDs	Active high
PA4	Data Bus	LCD/keypad module, motor driver, relay and relay LED	Active high
PA5–PA7	Data Bus	LCD/keypad module, motor control	Active high
PB0	Input	CLKB, <i>miniSD™ Card</i>	High
PB1	Input	CLKA, Programming Port	High (when not driven by CLKA)
PB2–PB5	Address Bus	LCD/keypad module	High
PB6–PB7	Address Bus	—	High
PC0	Output	TXD	Serial Port D High (disabled)
PC1	Input	RXD	
PC2	Output	TXC RS-485	Serial Port C High (RS-485 disabled)
PC3	Input	RXC RS-485	
PC4	Output	TXB, <i>miniSD™ Card</i>	Serial Port B* High (disabled)
PC5	Input	RXB, <i>miniSD™ Card</i>	
PC6	Output	TXA, Programming Port	Serial Port A High
PC7	Input	RXA, Programming Port	
PD0 [†]	Output	RCM3900 BSY LED off (shared with NAND flash busy)	High
PD1 [†]	Output	NAND flash chip enable	High (disabled)
PD2 [‡]	Input	<i>miniSD™ Card</i> card detect on RCM3900/RCM3910	High when <i>miniSD™ Card</i> is installed
PD3	Output	—	High (SPI CS disabled)
PD4–PD6	Input	—	High (disabled)
PD7	Output	RS-485 Tx enable	Low (RS-485 Tx disabled)
PE0–PE1	Input	IN0–IN1, J6	High
PE2 [†]	Output	Ethernet AEN, NAND flash function enable	High (disabled)
PE3	Output	Motor driver A clock pulse	Low (disabled)
PE4–PE5	Input	IN2–IN3, J6	High

Table B-5. Prototyping Board Use of Rabbit 3000 Parallel Ports (continued)

Port	I/O	Use	Initial State
PE6	Output	LCD/keypad module	High (disabled)
PE7	Output	Motor driver B clock pulse	High (disabled)
PF0	Input	Quadrature decoder	High
PF1–PF3	Input	Quadrature decoder	High
PF4–PF7	Output	Motor 1–4 control	Low (disabled)
PG0	Input	Switch S1	High
PG1	Input	Switch S2	High
PG2	Input	TXF RS-232	Serial Port F High (RS-232 disabled)
PG3	Input	RXF RS-232	
PG4	Output	Motor driver A enable	High (disabled)
PG5	Output	Motor driver B enable	High (disabled)
PG6	Input	TXE RS-232	Serial Port E High (RS-232 disabled)
PG7	Input	RXE RS-232	

* Serial Port B is not available on the Prototyping Board when the RCM3900/RCM3910 is plugged in.

† PD0, PD1, and PE2 are not normally available on the Prototyping Board because they are not brought out on RCM3900 header J61.

‡ PD2 is not brought out to the Prototyping Board when the RCM3900/RCM3910 RabbitCore modules are installed.

APPENDIX C. LCD/KEYPAD MODULE

An optional LCD/keypad is available for the Prototyping Board. Appendix C describes the LCD/keypad and provides the software function calls to make full use of the LCD/keypad.

C.1 Specifications

Two optional LCD/keypad modules—with or without a panel-mounted NEMA 4 water-resistant bezel—are available for use with the Prototyping Board. They are shown in Figure C-1.

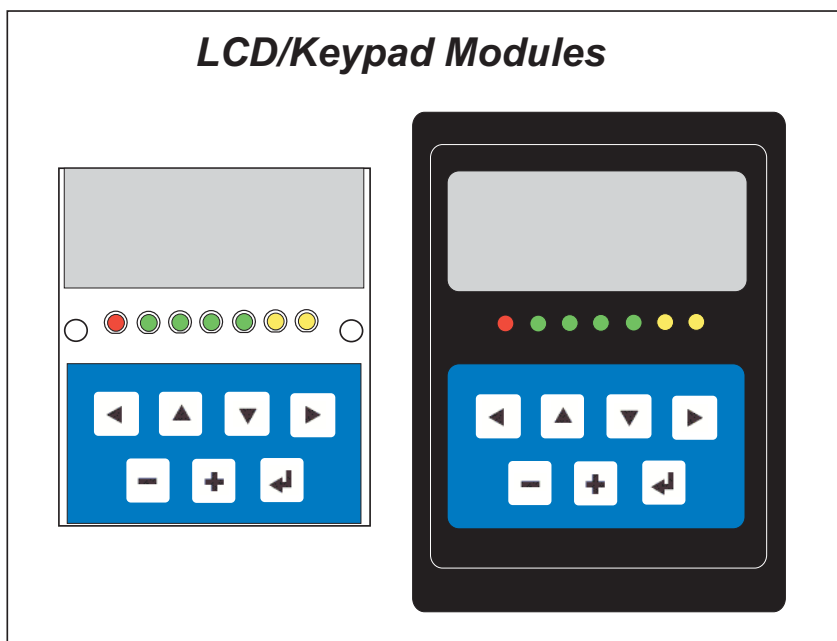

Figure C-1. LCD/Keypad Modules Versions

Only the version without the bezel can mount directly on the Prototyping Board; if you have the version with a bezel, you will have to remove the bezel to be able to mount the LCD/keypad module on the Prototyping Board. Either version of the LCD/keypad module can be installed at a remote location up to 60 cm (24") away. Contact your Rabbit sales representative or your authorized distributor for further assistance in purchasing an LCD/keypad module.

Mounting hardware and a 60 cm (24") extension cable are also available for the LCD/keypad module through your sales representative or authorized distributor.

Table C-1 lists the electrical, mechanical, and environmental specifications for the LCD/keypad module.

Table C-1. LCD/Keypad Specifications

Parameter	Specification
Board Size	2.60" × 3.00" × 0.75" (66 mm × 76 mm × 19 mm)
Bezel Size	4.50" × 3.60" × 0.30" (114 mm × 91 mm × 7.6 mm)
Temperature	Operating Range: 0°C to +50°C Storage Range: -40°C to +85°C
Humidity	5% to 95%, noncondensing
Power Consumption	1.5 W maximum*
Connections	Connects to high-rise header sockets on the Prototyping Board
LCD Panel Size	122 × 32 graphic display
Keypad	7-key keypad
LEDs	Seven user-programmable LEDs

* The backlight adds approximately 650 mW to the power consumption.

The LCD/keypad module has 0.1" IDC headers at J1, J2, and J3 for physical connection to other boards or ribbon cables. Figure C-2 shows the LCD/keypad module footprint. These values are relative to one of the mounting holes.

NOTE: All measurements are in inches followed by millimeters enclosed in parentheses. All dimensions have a manufacturing tolerance of ±0.01" (0.25 mm).

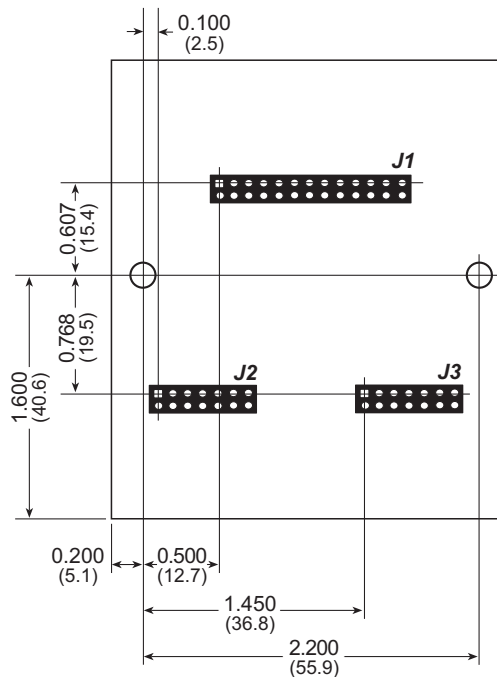

Figure C-2. User Board Footprint for LCD/Keypad Module

C.2 Contrast Adjustments for All Boards

Starting in 2005, LCD/keypad modules were factory-configured to optimize their contrast based on the voltage of the system they would be used in. Be sure to select a KDU3V LCD/keypad module for use with the Prototyping Board for the RCM3900 — these modules operate at 3.3 V. You may adjust the contrast using the potentiometer at R2 as shown in Figure C-3. LCD/keypad modules configured for 5 V may be used with the 3.3 V Prototyping Board, but the backlight will be dim.

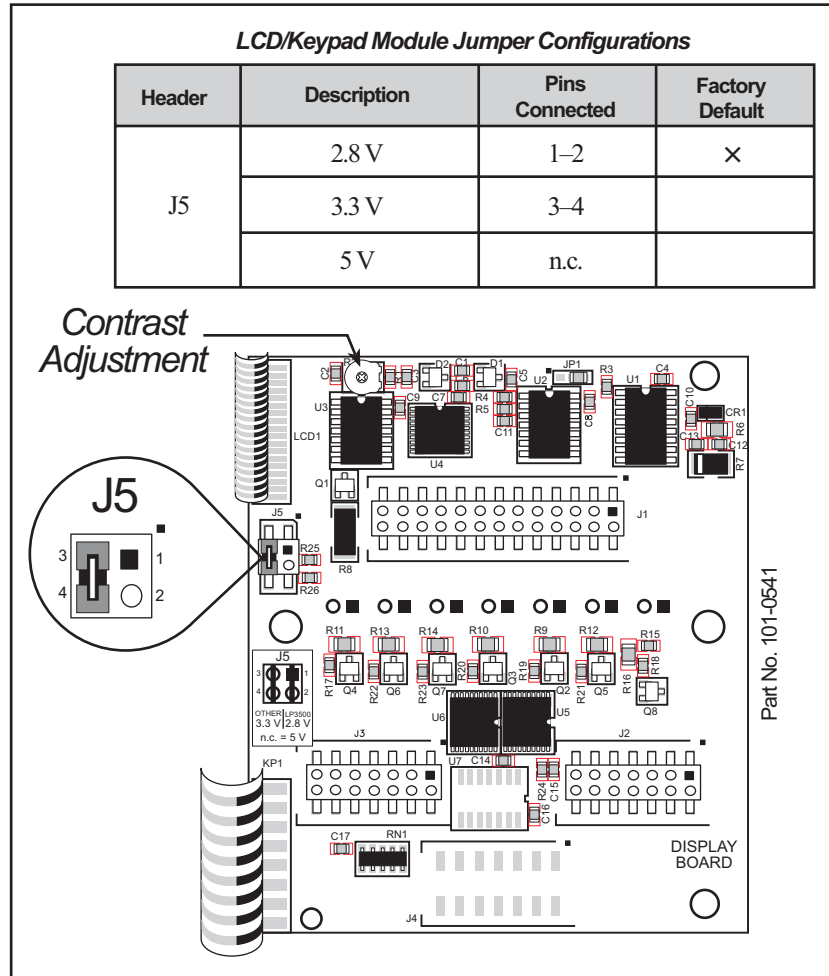

Figure C-3. LCD/Keypad Module Contrast Adjustments

You can set the contrast on the LCD display of pre-2005 LCD/keypad modules by adjusting the potentiometer at R2 or by setting the voltage for 3.3 V by connecting the jumper across pins 3–4 on header J5 as shown in Figure C-3. Only one of these two options is available on these LCD/keypad modules.

NOTE: Older LCD/keypad modules that do not have a header at J5 or a contrast adjustment potentiometer at R2 are limited to operate only at 5 V, and will not work with the Prototyping Board for the RCM3900. The older LCD/keypad modules are no longer being sold.

C.3 Keypad Labeling

The keypad may be labeled according to your needs. A template is provided in Figure C-4 to allow you to design your own keypad label insert.

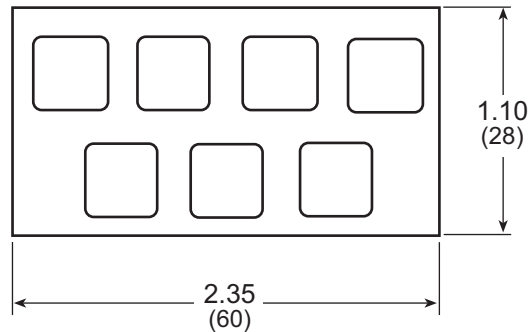

Figure C-4. Keypad Template

To replace the keypad legend, remove the old legend and insert your new legend prepared according to the template in Figure C-4. The keypad legend is located under the blue keypad matte, and is accessible from the left only as shown in Figure C-5.

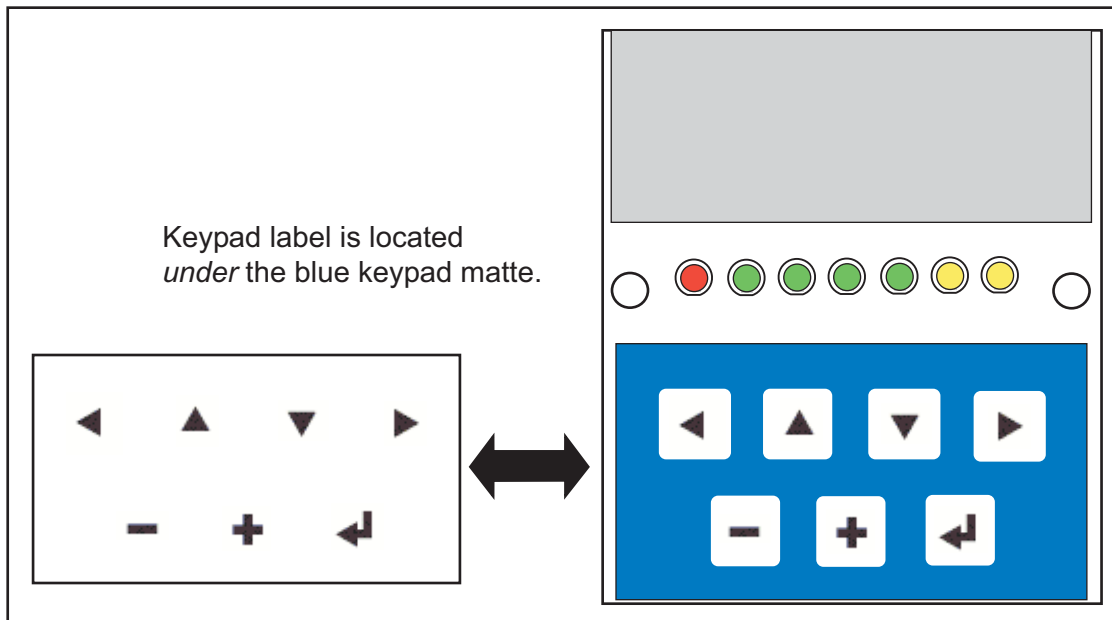

Figure C-5. Removing and Inserting Keypad Label

The sample program `KEYBASIC.C` in the `122x32_1x7` folder in `SAMPLES\LCD_KEYPAD` shows how to reconfigure the keypad for different applications.

C.4 Header Pinouts

Figure C-6 shows the pinouts for the LCD/keypad module.

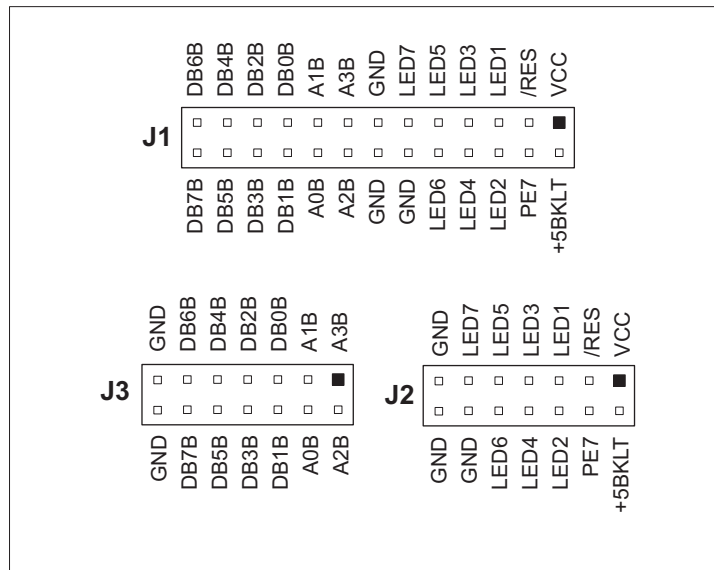

Figure C-6. LCD/Keypad Module Pinouts

C.4.1 I/O Address Assignments

The LCD and keypad on the LCD/keypad module are addressed by the /CS strobe as explained in Table C-2.

Table C-2. LCD/Keypad Module Address Assignment

Address	Function
0xE000	Device select base address (/CS)
0xE00–0xE07	LCD control
0xE08	LED enable
0xE09	Not used
0xE0A	7-key keypad
0xE0B (bits 0–6)	7-LED driver
0xE0B (bit 7)	LCD backlight on/off
0xE0C–0xE0F	Not used

C.5 Mounting LCD/Keypad Module on the Prototyping Board

Install the LCD/keypad module on header sockets LCD1JA, LCD1JB, and LCD1JC of the Prototyping Board as shown in Figure C-7. Be careful to align the pins over the headers, and do not bend them as you press down to mate the LCD/keypad module with the Prototyping Board.

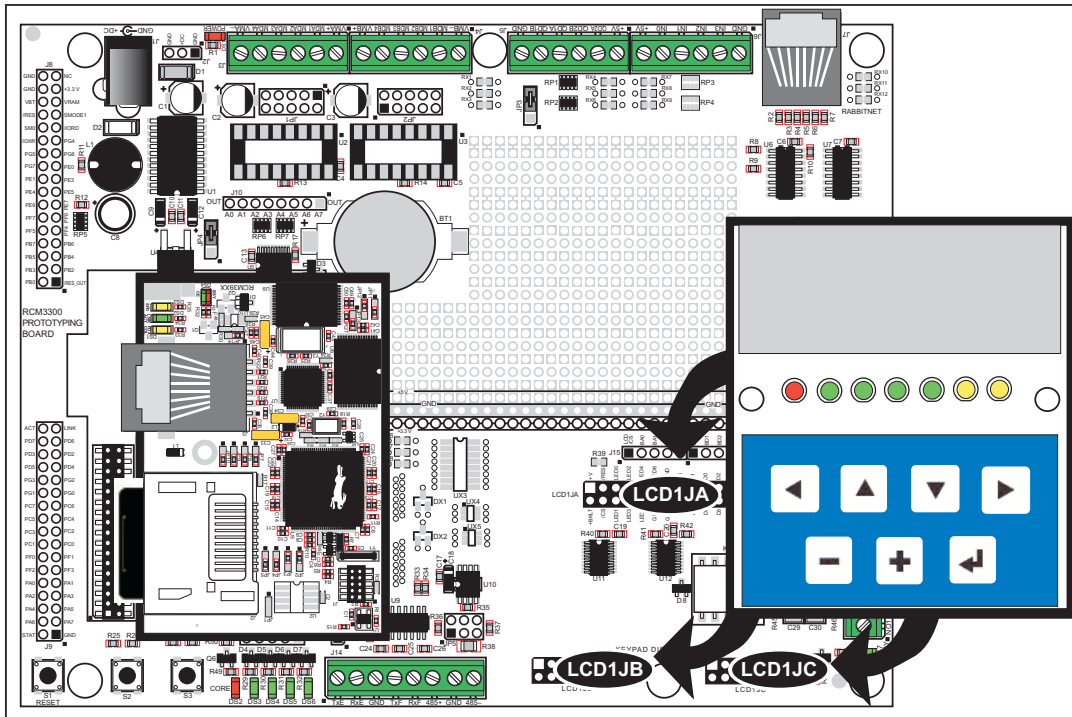

Figure C-7. Install LCD/Keypad Module on Prototyping Board

C.6 Bezel-Mount Installation

This section describes and illustrates how to bezel-mount the LCD/keypad module designed for remote installation. Follow these steps for bezel-mount installation.

1. Cut mounting holes in the mounting panel in accordance with the recommended dimensions in Figure C-8, then use the bezel faceplate to mount the LCD/keypad module onto the panel.

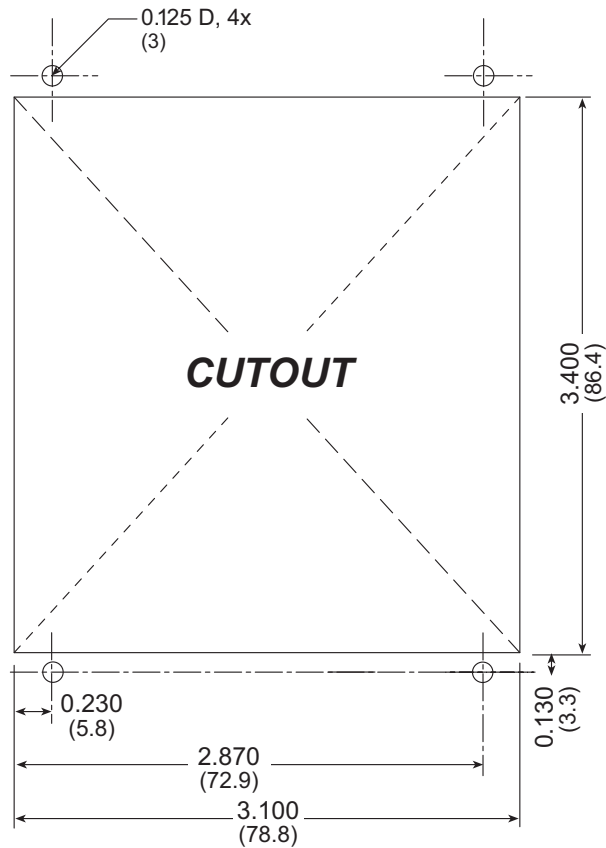

Figure C-8. Recommended Cutout Dimensions

2. Carefully “drop in” the LCD/keypad module with the bezel and gasket attached.

3. Fasten the unit with the four 4-40 screws and washers included with the LCD/keypad module. If your panel is thick, use a 4-40 screw that is approximately 3/16" (5 mm) longer than the thickness of the panel.

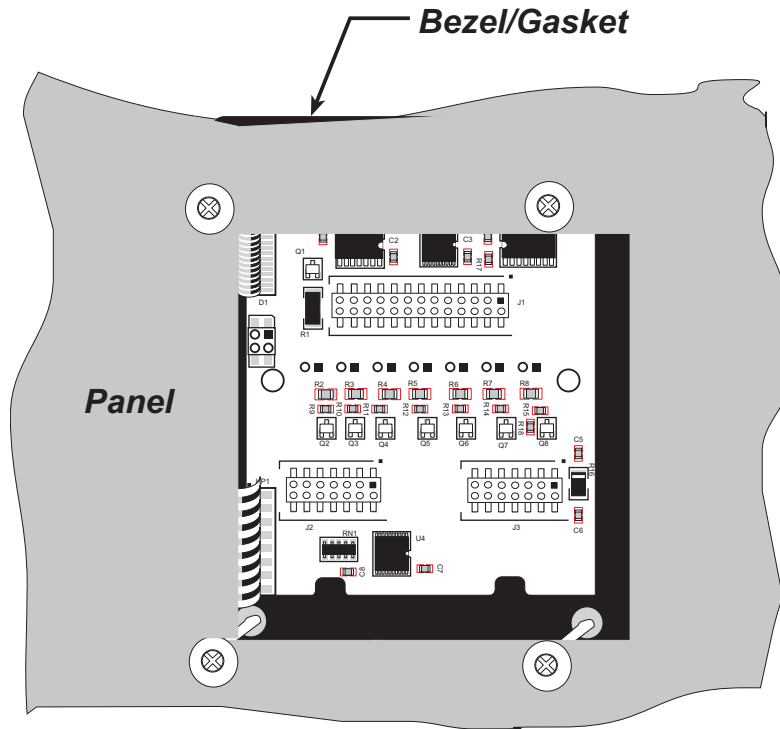

Figure C-9. LCD/Keypad Module Mounted in Panel (rear view)

Carefully tighten the screws until the gasket is compressed and the plastic bezel faceplate is touching the panel.

Do not tighten each screw fully before moving on to the next screw. Apply only one or two turns to each screw in sequence until all are tightened manually as far as they can be so that the gasket is compressed and the plastic bezel faceplate is touching the panel.

C.6.1 Connect the LCD/Keypad Module to Your Prototyping Board

The LCD/keypad module can be located as far as 2 ft. (60 cm) away from the Prototyping Board, and is connected via a ribbon cable as shown in Figure C-10.

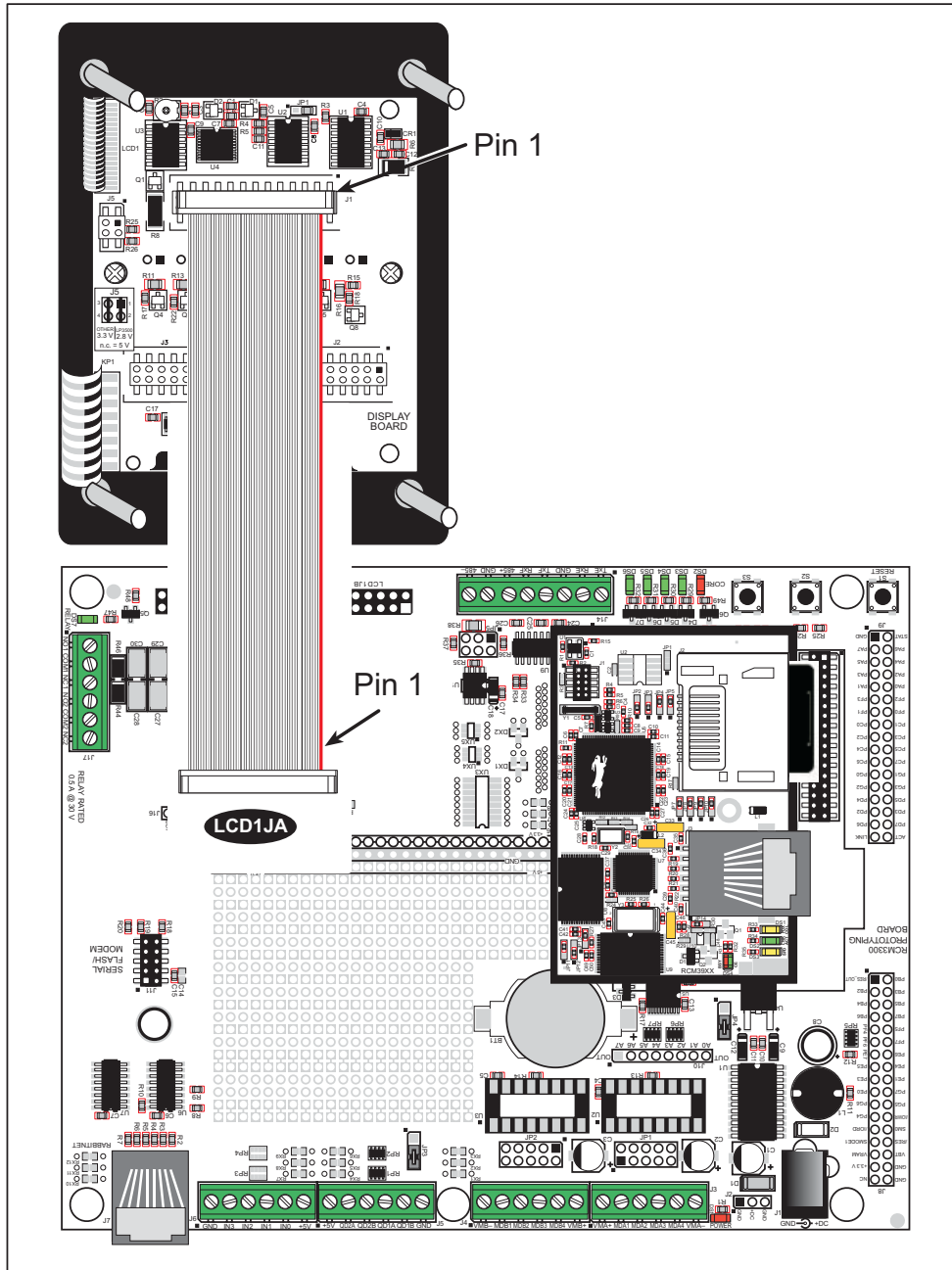

Figure C-10. Connecting LCD/Keypad Module to Prototyping Board

Note the locations and connections relative to pin 1 on both the Prototyping Board and the LCD/keypad module.

Rabbit offers 2 ft. (60 cm) extension cables. Contact your authorized distributor or a Rabbit sales representative for more information.

C.7 Sample Programs

Sample programs illustrating the use of the LCD/keypad module with the Prototyping Board are provided in the `SAMPLES\RCM3900\LCD_KEYPAD` folder.

These sample programs use the auxiliary I/O bus on the Rabbit 3000 chip, and so the `#define PORTA_AUX_IO` line is already included in the sample programs.

Each sample program has comments that describe the purpose and function of the program. Follow the instructions at the beginning of the sample program. To run a sample program, open it with the **File** menu (if it is not still open), then compile and run it by pressing **F9**. The RCM3900 must be connected to a PC using the serial programming cable as described in Chapter 2, “Getting Started.”

Complete information on Dynamic C is provided in the *Dynamic C User’s Manual*.

- **KEYPADTOLED.C**—This program demonstrates the use of the external I/O bus. The program will light up an LED on the LCD/keypad module and will display a message on the LCD when a key press is detected. The DS3, DS4, DS5, and DS6 LEDs on the Prototyping Board and the red **BSY** LED (DS4) on the RCM3900 module will also light up.
- **LCDKEYFUN.C**—This program demonstrates how to draw primitive features from the graphic library (lines, circles, polygons), and also demonstrates the keypad with the key release option.
- **SWITCHTOLCD.C**—This program demonstrates the use of the external I/O bus. The program will light up an LED on the LCD/keypad module and will display a message on the LCD when a switch press is detected. The DS1 and DS2 LEDs on the Prototyping Board will also light up.

Additional sample programs are available in the `SAMPLES\LCD_KEYPAD\122x32_1x7` folder.

C.8 LCD/Keypad Module Function Calls

When mounted on the Prototyping Board, the LCD/keypad module uses the external I/O bus on the Rabbit 3000 chip. Remember to add the line

```
#define PORTA_AUX_IO
```

to the beginning of any programs using the auxiliary I/O bus.

C.8.1 LCD/Keypad Module Initialization

The function used to initialize the LCD/keypad module can be found in the Dynamic C `LIB\DISPLAYS\LCD122KEY7.LIB` library.

`dispInit`

```
void dispInit();
```

DESCRIPTION

Initializes the LCD/keypad module. The keypad is set up using `keypadDef()` or `keyConfig()` after this function call.

RETURN VALUE

None.

C.8.2 LEDs

When power is applied to the LCD/keypad module for the first time, the red LED (DS1) will come on, indicating that power is being applied to the LCD/keypad module. The red LED is turned off when the `brdInit` function executes.

One function is available to control the LEDs, and can be found in the Dynamic C `LIB\DISPLAYS\LCD122KEY7.LIB` library.

`displedOut`

```
void dispLEDOut(int led, int value);
```

DESCRIPTION

LED on/off control. This function will only work when the LCD/keypad module is installed on the Prototyping Board.

PARAMETERS

<code>led</code>	is the LED to control. 0 = LED DS1 1 = LED DS2 2 = LED DS3 3 = LED DS4 4 = LED DS5 5 = LED DS6 6 = LED DS7
<code>value</code>	is the value used to control whether the LED is on or off (0 or 1). 0 = off 1 = on

RETURN VALUE

None.

C.8.3 LCD Display

The functions used to control the LCD display are contained in the `LIB\DISPLAYS\GRAPHIC\GRAPHIC.LIB` library . When x and y coordinates on the display screen are specified, x can range from 0 to 121, and y can range from 0 to 31. These numbers represent pixels from the top left corner of the display.

`glInit`

```
void glInit(void);
```

DESCRIPTION

Initializes the display devices, clears the screen.

RETURN VALUE

None.

SEE ALSO

`glDispOnOFF`, `glBacklight`, `glSetContrast`, `glPlotDot`, `glBlock`, `glPlotDot`, `glPlotPolygon`, `glPlotCircle`, `glHScroll`, `glVScroll`, `glXFontInit`, `glPrintf`, `glPutChar`, `glSetBrushType`, `glBuffLock`, `glBuffUnlock`, `glPlotLine`

`glBackLight`

```
void glBackLight(int onOff);
```

DESCRIPTION

Turns the display backlight on or off.

PARAMETER

<code>onOff</code>	turns the backlight on or off
	1—turn the backlight on
	0—turn the backlight off

RETURN VALUE

None.

SEE ALSO

`glInit`, `glDispOnoff`, `glSetContrast`

glDispOnOff

```
void glDispOnOff(int onOff);
```

DESCRIPTION

Sets the LCD screen on or off. Data will not be cleared from the screen.

PARAMETER

onOff	turns the LCD screen on or off
	1—turn the LCD screen on
	0—turn the LCD screen off

RETURN VALUE

None.

SEE ALSO

`glInit`, `glSetContrast`, `glBackLight`

glSetContrast

```
void glSetContrast(unsigned level);
```

DESCRIPTION

Sets display contrast.

NOTE: This function is not used with the LCD/keypad module since the support circuits are not available on the LCD/keypad module.

glFillScreen

```
void glFillScreen(int pattern);
```

DESCRIPTION

Fills the LCD display screen with a pattern.

PARAMETER

The screen will be set to all black if **pattern** is 0xFF, all white if **pattern** is 0x00, and vertical stripes for any other pattern.

RETURN VALUE

None.

SEE ALSO

`glBlock`, `glBlankScreen`, `glPlotPolygon`, `glPlotCircle`

glBlankScreen

```
void glBlankScreen(void);
```

DESCRIPTION

Blanks the LCD display screen (sets LCD display screen to white).

RETURN VALUE

None.

SEE ALSO

`glFillScreen`, `glBlock`, `glPlotPolygon`, `glPlotCircle`

glFillRegion

```
void glFillRegion(int left, int top, int width, int height,  
char pattern);
```

DESCRIPTION

Fills a rectangular block in the LCD buffer with the pattern specified. Any portion of the block that is outside the LCD display area will be clipped.

PARAMETERS

left	the x coordinate of the top left corner of the block.
top	the y coordinate of the top left corner of the block.
width	the width of the block.
height	the height of the block.
pattern	the bit pattern to display (all black if pattern is 0xFF, all white if pattern is 0x00, and vertical stripes for any other pattern).

RETURN VALUE

None.

SEE ALSO

`glFillScreen`, `glBlankScreen`, `glBlock`, `glBlankRegion`

glFastFillRegion

```
void glFastFillRegion(int left, int top, int width, int height,  
    char pattern);
```

DESCRIPTION

Fills a rectangular block in the LCD buffer with the pattern specified. The block left and width parameters must be byte-aligned. Any portion of the block that is outside the LCD display area will be clipped.

PARAMETERS

left	the x coordinate of the top left corner of the block.
top	the y coordinate of the top left corner of the block.
width	the width of the block.
height	the height of the block.
pattern	the bit pattern to display (all black if pattern is 0xFF, all white if pattern is 0x00, and vertical stripes for any other pattern).

RETURN VALUE

None.

SEE ALSO

`glFillScreen`, `glBlankScreen`, `glBlock`, `glBlankRegion`

glBlankRegion

```
void glBlankRegion(int left, int top, int width, int height);
```

DESCRIPTION

Clears a region on the LCD display. The block left and width parameters must be byte-aligned. Any portion of the block that is outside the LCD display area will be clipped.

PARAMETERS

left	the <i>x</i> coordinate of the top left corner of the block (<i>x</i> must be evenly divisible by 8).
top	the <i>y</i> coordinate of the top left corner of the block.
width	the width of the block (must be evenly divisible by 8).
height	the height of the block.

RETURN VALUE

None.

SEE ALSO

`glFillScreen`, `glBlankScreen`, `glBlock`

glBlock

```
void glBlock(int left, int top, int width, int height);
```

DESCRIPTION

Draws a rectangular block in the page buffer and on the LCD if the buffer is unlocked. Any portion of the block that is outside the LCD display area will be clipped.

PARAMETERS

left	the x coordinate of the top left corner of the block.
top	the y coordinate of the top left corner of the block.
width	the width of the block.
height	the height of the block.

RETURN VALUE

None.

SEE ALSO

`glFillScreen`, `glBlankScreen`, `glPlotPolygon`, `glPlotCircle`

glPlotVPolygon

```
void glPlotVPolygon(int n, int *pFirstCoord);
```

DESCRIPTION

Plots the outline of a polygon in the LCD page buffer, and on the LCD if the buffer is unlocked. Any portion of the polygon that is outside the LCD display area will be clipped. If fewer than 3 vertices are specified, the function will return without doing anything.

PARAMETERS

n	the number of vertices.
pFirstCoord	a pointer to array of vertex coordinates: x1,y1, x2,y2, x3,y3, ...

RETURN VALUE

None.

SEE ALSO

`glPlotPolygon`, `glFillPolygon`, `glFillVPolygon`

glPlotPolygon

```
void glPlotPolygon(int n, int y1, int x2, int y2, ...);
```

DESCRIPTION

Plots the outline of a polygon in the LCD page buffer and on the LCD if the buffer is unlocked. Any portion of the polygon that is outside the LCD display area will be clipped. If fewer than 3 vertices are specified, the function will return without doing anything.

PARAMETERS

n	the number of vertices.
y1	the y coordinate of the first vertex.
x1	the x coordinate of the first vertex.
y2	the y coordinate of the second vertex.
x2	the x coordinate of the second vertex.
...	the coordinates of additional vertices.

RETURN VALUE

None.

SEE ALSO

`glPlotVPolygon`, `glFillPolygon`, `glFillVPolygon`

glFillVPolygon

```
void glFillVPolygon(int n, int *pFirstCoord);
```

DESCRIPTION

Fills a polygon in the LCD page buffer and on the LCD screen if the buffer is unlocked. Any portion of the polygon that is outside the LCD display area will be clipped. If fewer than 3 vertices are specified, the function will return without doing anything.

PARAMETERS

n	the number of vertices.
pFirstCoord	a pointer to array of vertex coordinates: x1,y1, x2,y2, x3,y3, ...

RETURN VALUE

None.

SEE ALSO

`glFillPolygon`, `glPlotPolygon`, `glPlotVPolygon`

glFillPolygon

```
void glFillPolygon(int n, int x1, int y1, int x2, int y2, ...);
```

DESCRIPTION

Fills a polygon in the LCD page buffer and on the LCD if the buffer is unlocked. Any portion of the polygon that is outside the LCD display area will be clipped. If fewer than 3 vertices are specified, the function will return without doing anything.

PARAMETERS

n	the number of vertices.
x1	the x coordinate of the first vertex.
y1	the y coordinate of the first vertex.
x2	the x coordinate of the second vertex.
y2	the y coordinate of the second vertex.
...	the coordinates of additional vertices.

RETURN VALUE

None.

SEE ALSO

`glFillVPolygon`, `glPlotPolygon`, `glPlotVPolygon`

glPlotCircle

```
void glPlotCircle(int xc, int yc, int rad);
```

DESCRIPTION

Draws the outline of a circle in the LCD page buffer and on the LCD if the buffer is unlocked. Any portion of the circle that is outside the LCD display area will be clipped.

PARAMETERS

xc	the x coordinate of the center of the circle.
yc	the y coordinate of the center of the circle.
rad	the radius of the center of the circle (in pixels).

RETURN VALUE

None.

SEE ALSO

`glFillColor`, `glPlotPolygon`, `glFillPolygon`

glFillColor

```
void glFillColor(int xc, int yc, int rad);
```

DESCRIPTION

Draws a filled circle in the LCD page buffer and on the LCD if the buffer is unlocked. Any portion of the circle that is outside the LCD display area will be clipped.

PARAMETERS

xc	the x coordinate of the center of the circle.
yc	the y coordinate of the center of the circle.
rad	the radius of the center of the circle (in pixels).

RETURN VALUE

None.

SEE ALSO

`glPlotCircle`, `glPlotPolygon`, `glFillPolygon`

glXFontInit

```
void glXFontInit(fontInfo *pInfo, char pixWidth, char pixHeight,  
    unsigned startChar, unsigned endChar, unsigned long xmemBuffer);
```

DESCRIPTION

Initializes the font descriptor structure, where the font is stored in **xmem**. Each font character's bitmap is column major and byte aligned.

PARAMETERS

pInfo	a pointer to the font descriptor to be initialized.
pixWidth	the width (in pixels) of each font item.
pixHeight	the height (in pixels) of each font item.
startChar	the value of the first printable character in the font character set.
endChar	the value of the last printable character in the font character set.
xmemBuffer	the xmem pointer to a linear array of font bitmaps.

RETURN VALUE

None.

SEE ALSO

`glPrintf`

glFontCharAddr

```
unsigned long glFontCharAddr(fontInfo *pInfo, char letter);
```

DESCRIPTION

Returns the **xmem** address of the character from the specified font set.

PARAMETERS

pInfo	pointer to the xmem address of the bitmap font set.
letter	an ASCII character.

RETURN VALUE

xmem address of bitmap character font, column major and byte-aligned.

SEE ALSO

glPutFont, glPrintf

glPutFont

```
void glPutFont(int x, int y, fontInfo *pInfo, char code);
```

DESCRIPTION

Puts an entry from the font table to the page buffer and on the LCD if the buffer is unlocked. Each font character's bitmap is column major and byte-aligned. Any portion of the bitmap character that is outside the LCD display area will be clipped.

PARAMETERS

x	the x coordinate (column) of the top left corner of the text.
y	the y coordinate (row) of the top left corner of the text.
pInfo	a pointer to the font descriptor.
code	the ASCII character to display.

RETURN VALUE

None.

SEE ALSO

glFontCharAddr, glPrintf

glSetPfStep

```
void glSetPfStep(int stepX, int stepY);
```

DESCRIPTION

Sets the `glPrintf()` printing step direction. The *x* and *y* step directions are independent signed values. The actual step increments depend on the height and width of the font being displayed, which are multiplied by the step values.

PARAMETERS

<code>stepX</code>	the <code>glPrintf</code> <i>x</i> step value
<code>stepY</code>	the <code>glPrintf</code> <i>y</i> step value

RETURN VALUE

None.

SEE ALSO

Use `glGetPfStep()` to examine the current *x* and *y* printing step direction.

glGetPfStep

```
int glGetPfStep(void);
```

DESCRIPTION

Gets the current `glPrintf()` printing step direction. Each step direction is independent of the other, and is treated as an 8-bit signed value. The actual step increments depends on the height and width of the font being displayed, which are multiplied by the step values.

RETURN VALUE

The *x* step is returned in the MSB, and the *y* step is returned in the LSB of the integer result.

SEE ALSO

Use `glSetPfStep()` to control the *x* and *y* printing step direction.

glPutChar

```
void glPutChar(char ch, char *ptr, int *cnt, glPutCharInst
               *pInst)
```

DESCRIPTION

Provides an interface between the **STDIO** string-handling functions and the graphic library. The **STDIO** string-formatting function will call this function, one character at a time, until the entire formatted string has been parsed. Any portion of the bitmap character that is outside the LCD display area will be clipped.

PARAMETERS

ch	the character to be displayed on the LCD.
ptr	not used, but is a place holder for a pointer to STDIO string functions.
cnt	not used, is a place holder for a pointer to STDIO string functions.
pInst	a pointer to the font descriptor.

RETURN VALUE

None.

SEE ALSO

`glPrintf`, `glPutFont`, `doprnt`

glPrintf

```
void glPrintf(int x, int y, fontInfo *pInfo, char *fmt, ...);
```

DESCRIPTION

Prints a formatted string (much like **printf**) on the LCD screen. Only the character codes that exist in the font set are printed, all others are skipped. For example, '\b', '\t', '\n' and '\r' (ASCII backspace, tab, new line, and carriage return, respectively) will be printed if they exist in the font set, but will not have any effect as control characters. Any portion of the bitmap character that is outside the LCD display area will be clipped.

PARAMETERS

x	the x coordinate (column) of the upper left corner of the text.
y	the y coordinate (row) of the upper left corner of the text.
pInfo	a pointer to the font descriptor.
fmt	pointer to a formatted string.
...	formatted string conversion parameter(s).

EXAMPLE

```
glprintf(0,0, &fi12x16, "Test %d\n", count);
```

RETURN VALUE

None.

SEE ALSO

`glXFontInit`

glBuffLock

```
void glBuffLock(void);
```

DESCRIPTION

Increments LCD screen locking counter. Graphic calls are recorded in the LCD memory buffer and are not transferred to the LCD if the counter is non-zero.

NOTE: `glBuffLock()` and `glBuffUnlock()` can be nested up to a level of 255, but be sure to balance the calls. It is not a requirement to use these procedures, but a set of `glBuffLock()` and `glBuffUnlock()` bracketing a set of related graphic calls speeds up the rendering significantly.

RETURN VALUE

None.

SEE ALSO

`glBuffUnlock`, `glSwap`

glBuffUnlock

```
void glBuffUnlock(void);
```

DESCRIPTION

Decrements the LCD screen locking counter. The contents of the LCD buffer are transferred to the LCD if the counter goes to zero.

RETURN VALUE

None.

SEE ALSO

`glBuffLock`, `glSwap`

glSwap

```
void glSwap(void);
```

DESCRIPTION

Checks the LCD screen locking counter. The contents of the LCD buffer are transferred to the LCD if the counter is zero.

RETURN VALUE

None.

SEE ALSO

`glBuffUnlock`, `glBuffLock`, `_glSwapData` (located in the library specifically for the LCD that you are using)

glSetBrushType

```
void glSetBrushType(int type);
```

DESCRIPTION

Sets the drawing method (or color) of pixels drawn by subsequent graphic calls.

PARAMETER

type value can be one of the following macros.

- PIXBLACK** draws black pixels (turns pixel on).
- PIXWHITE** draws white pixels (turns pixel off).
- PIXXOR** draws old pixel XOR'ed with the new pixel.

RETURN VALUE

None.

SEE ALSO

`glGetBrushType`

glGetBrushType

```
int glGetBrushType(void);
```

DESCRIPTION

Gets the current method (or color) of pixels drawn by subsequent graphic calls.

RETURN VALUE

The current brush type.

SEE ALSO

`glSetBrushType`

glXGetBitmap

```
void glXGetBitmap(int x, int y, int bmWidth, int bmHeight,  
unsigned long xBm);
```

DESCRIPTION

Gets a bitmap from the LCD page buffer and stores it in **xmem** RAM. This function automatically calls `glXGetFastmap` if the left edge of the bitmap is byte-aligned and the left edge and width are each evenly divisible by 8.

This function call is intended for use only when a graphic engine is used to interface with the LCD/keypad module.

PARAMETERS

x	the <i>x</i> coordinate in pixels of the top left corner of the bitmap (<i>x</i> must be evenly divisible by 8).
y	the <i>y</i> coordinate in pixels of the top left corner of the bitmap.
bmWidth	the width in pixels of the bitmap (must be evenly divisible by 8).
bmHeight	the height in pixels of the bitmap.
xBm	the xmem RAM storage address of the bitmap.

RETURN VALUE

None.

glXGetFastmap

```
void glXGetFastmap(int left, int top, int width, int height,  
    unsigned long xmemptr);
```

DESCRIPTION

Draws bitmap in the specified space. The data for the bitmap are stored in **xmem**. This function is similar to **glXPutBitmap()**, except that it's faster. The bitmap must be byte-aligned. Any portion of a bitmap image or character that is outside the LCD display area will be clipped.

This function call is intended for use only when a graphic engine is used to interface with the LCD/keypad module.

PARAMETERS

left	the x coordinate of the top left corner of the bitmap (x must be evenly divisible by 8).
top	the y coordinate in pixels of the top left corner of the bitmap.
width	the width of the bitmap (must be evenly divisible by 8).
height	the height of the bitmap.
xmemptr	the xmem RAM storage address of the bitmap.

RETURN VALUE

None.

SEE ALSO

glXPutBitmap, **glPrintf**

glPlotDot

```
void glPlotDot(int x, int y);
```

DESCRIPTION

Draws a single pixel in the LCD buffer, and on the LCD if the buffer is unlocked. If the coordinates are outside the LCD display area, the dot will not be plotted.

PARAMETERS

x	the x coordinate of the dot.
y	the y coordinate of the dot.

RETURN VALUE

None.

SEE ALSO

`glPlotline`, `glPlotPolygon`, `glPlotCircle`

glPlotLine

```
void glPlotLine(int x0, int y0, int x1, int y1);
```

DESCRIPTION

Draws a line in the LCD buffer, and on the LCD if the buffer is unlocked. Any portion of the line that is beyond the LCD display area will be clipped.

PARAMETERS

x0	the x coordinate of one endpoint of the line.
y0	the y coordinate of one endpoint of the line.
x1	the x coordinate of the other endpoint of the line.
y1	the y coordinate of the other endpoint of the line.

RETURN VALUE

None.

SEE ALSO

`glPlotDot`, `glPlotPolygon`, `glPlotCircle`

glLeft1

```
void glLeft1(int left, int top, int cols, int rows);
```

DESCRIPTION

Scrolls byte-aligned window left one pixel, right column is filled by current pixel type (color).

PARAMETERS

left	the top left corner of bitmap, must be evenly divisible by 8, otherwise truncates.
top	the top left corner of the bitmap.
cols	the number of columns in the window, must be evenly divisible by 8, otherwise truncates.
rows	the number of rows in the window.

RETURN VALUE

None.

SEE ALSO

`glHScroll`, `glRight1`

glRight1

```
void glRight1(int left, int top, int cols, int rows);
```

DESCRIPTION

Scrolls byte-aligned window right one pixel, left column is filled by current pixel type (color).

PARAMETERS

left	the top left corner of bitmap, must be evenly divisible by 8, otherwise truncates.
top	the top left corner of the bitmap.
cols	the number of columns in the window, must be evenly divisible by 8, otherwise truncates.
rows	the number of rows in the window.

RETURN VALUE

None.

SEE ALSO

`glHScroll`, `glLeft1`

glUp1

```
void glUp1(int left, int top, int cols, int rows);
```

DESCRIPTION

Scrolls byte-aligned window up one pixel, bottom column is filled by current pixel type (color).

PARAMETERS

left	the top left corner of bitmap, must be evenly divisible by 8, otherwise truncates.
top	the top left corner of the bitmap.
cols	the number of columns in the window, must be evenly divisible by 8, otherwise truncates.
rows	the number of rows in the window.

RETURN VALUE

None.

SEE ALSO

`glVScroll`, `glDown1`

glDown1

```
void glDown1(int left, int top, int cols, int rows);
```

DESCRIPTION

Scrolls byte-aligned window down one pixel, top column is filled by current pixel type (color).

PARAMETERS

left	the top left corner of bitmap, must be evenly divisible by 8, otherwise truncates.
top	the top left corner of the bitmap.
cols	the number of columns in the window, must be evenly divisible by 8, otherwise truncates.
rows	the number of rows in the window.

RETURN VALUE

None.

SEE ALSO

`glVScroll`, `glUp1`

glHScroll

```
void glHScroll(int left, int top, int cols, int rows, int nPix);
```

DESCRIPTION

Scrolls right or left, within the defined window by x number of pixels. The opposite edge of the scrolled window will be filled in with white pixels. The window must be byte-aligned.

Parameters will be verified for the following:

1. The **left** and **cols** parameters will be verified that they are evenly divisible by 8. If not, they will be truncated to a value that is a multiple of 8.
2. Parameters will be checked to verify that the scrolling area is valid. The minimum scrolling area is a width of 8 pixels and a height of one row.

PARAMETERS

left	the top left corner of bitmap, must be evenly divisible by 8.
top	the top left corner of the bitmap.
cols	the number of columns in the window, must be evenly divisible by 8.
rows	the number of rows in the window.
nPix	the number of pixels to scroll within the defined window (a negative value will produce a scroll to the left).

RETURN VALUE

None.

SEE ALSO

`glVScroll`

glVScroll

```
void glVScroll(int left, int top, int cols, int rows, int nPix);
```

DESCRIPTION

Scrolls up or down, within the defined window by x number of pixels. The opposite edge of the scrolled window will be filled in with white pixels. The window must be byte-aligned.

Parameters will be verified for the following:

1. The **left** and **cols** parameters will be verified that they are evenly divisible by 8. If not, they will be truncated to a value that is a multiple of 8.
2. Parameters will be checked to verify that the scrolling area is valid. The minimum scrolling area is a width of 8 pixels and a height of one row.

PARAMETERS

left	the top left corner of bitmap, must be evenly divisible by 8.
top	the top left corner of the bitmap.
cols	the number of columns in the window, must be evenly divisible by 8.
rows	the number of rows in the window.
nPix	the number of pixels to scroll within the defined window (a negative value will produce a scroll up).

RETURN VALUE

None.

SEE ALSO

`glHScroll`

glXPutBitmap

```
void glXPutBitmap(int left, int top, int width, int height,  
    unsigned long bitmap);
```

DESCRIPTION

Draws bitmap in the specified space. The data for the bitmap are stored in **xmem**. This function calls **glXPutFastmap()** automatically if the bitmap is byte-aligned (the left edge and the width are each evenly divisible by 8).

Any portion of a bitmap image or character that is outside the LCD display area will be clipped.

PARAMETERS

left	the top left corner of the bitmap.
top	the top left corner of the bitmap.
width	the width of the bitmap.
height	the height of the bitmap.
bitmap	the address of the bitmap in xmem .

RETURN VALUE

None.

SEE ALSO

glXPutFastmap, **glPrintf**

glXPutFastmap

```
void glXPutFastmap(int left, int top, int width, int height,  
    unsigned long bitmap);
```

DESCRIPTION

Draws bitmap in the specified space. The data for the bitmap are stored in **xmem**. This function is like **glXPutBitmap()**, except that it is faster. The restriction is that the bitmap must be byte-aligned.

Any portion of a bitmap image or character that is outside the LCD display area will be clipped.

PARAMETERS

left	the top left corner of the bitmap, must be evenly divisible by 8, otherwise truncates.
top	the top left corner of the bitmap.
width	the width of the bitmap, must be evenly divisible by 8, otherwise truncates.
height	the height of the bitmap.
bitmap	the address of the bitmap in xmem .

RETURN VALUE

None.

SEE ALSO

glXPutBitmap, **glPrintf**

TextWindowFrame

```
int TextWindowFrame(windowFrame *window, fontInfo *pFont, int x,  
    int y, int winWidth, int winHeight);
```

DESCRIPTION

Defines a text-only display window. This function provides a way to display characters within the text window using only character row and column coordinates. The text window feature provides end-of-line wrapping and clipping after the character in the last column and row is displayed.

NOTE: Execute the `TextWindowFrame()` function before other `Text...` functions.

PARAMETERS

window	a pointer to the window frame descriptor.
pFont	a pointer to the font descriptor.
x	the <i>x</i> coordinate of the top left corner of the text window frame.
y	the <i>y</i> coordinate of the top left corner of the text window frame.
winWidth	the width of the text window frame.
winHeight	the height of the text window frame.

RETURN VALUE

- 0—window frame was successfully created.
- 1—*x* coordinate + width has exceeded the display boundary.
- 2—*y* coordinate + height has exceeded the display boundary.
- 3—Invalid **winHeight** and/or **winWidth** parameter value.

TextBorderInit

```
void TextBorderInit(windowFrame *wPtr, int border, char *title);
```

DESCRIPTION

This function initializes the window frame structure with the border and title information.

NOTE: Execute the `TextWindowFrame()` function before using this function.

PARAMETERS

wPtr	a pointer to the window frame descriptor.
border	the border style: SINGLE_LINE —The function will draw a single-line border around the text window. DOUBLE_LINE —The function will draw a double-line border around the text window.
title	a pointer to the title information: If a NULL string is detected, then no title is written to the text menu. If a string is detected, then it will be written center-aligned to the top of the text menu box.

RETURN VALUE

None.

SEE ALSO

`TextBorder`, `TextGotoXY`, `TextPutChar`, `TextWindowFrame`, `TextCursorLocation`

TextBorder

```
void TextBorder(windowFrame *wPtr);
```

DESCRIPTION

This function displays the border for a given window frame. This function will automatically adjust the text window parameters to accommodate the space taken by the text border. This adjustment will only occur once after the `TextBorderInit()` function executes.

NOTE: Execute the `TextWindowFrame()` function before using this function.

PARAMETER

wPtr a pointer to the window frame descriptor.

RETURN VALUE

None.

SEE ALSO

`TextBorderInit`, `TextGotoXY`, `TextPutChar`, `TextWindowFrame`,
`TextCursorPosition`

TextGotoXY

```
void TextGotoXY(windowFrame *window, int col, int row);
```

DESCRIPTION

Sets the cursor location to display the next character. The display location is based on the height and width of the character to be displayed.

NOTE: Execute the `TextWindowFrame()` function before using this function.

PARAMETERS

window a pointer to a font descriptor.

col a character column location.

row a character row location.

RETURN VALUE

None.

SEE ALSO

`TextPutChar`, `TextPrintf`, `TextWindowFrame`

TextCursorLocation

```
void TextCursorLocation(windowFrame *window, int *col, int *row);
```

DESCRIPTION

Gets the current cursor location that was set by a graphic **Text...** function.

NOTE: Execute the **TextWindowFrame()** function before using this function.

PARAMETERS

window	a pointer to a font descriptor.
col	a pointer to cursor column variable.
row	a pointer to cursor row variable.

RETURN VALUE

Lower word = Cursor Row location
Upper word = Cursor Column location

SEE ALSO

TextGotoXY, TextPrintf, TextWindowFrame, TextCursorLocation

TextPutChar

```
void TextPutChar(struct windowFrame *window, char ch);
```

DESCRIPTION

Displays a character on the display where the cursor is currently pointing. Once a character is displayed, the cursor will be incremented to the next character position. If any portion of a bitmap character is outside the LCD display area, the character will not be displayed.

NOTE: Execute the `TextWindowFrame()` function before using this function.

PARAMETERS

<code>window</code>	a pointer to a font descriptor.
<code>ch</code>	a character to be displayed on the LCD.

RETURN VALUE

None.

SEE ALSO

`TextGotoXY`, `TextPrintf`, `TextWindowFrame`, `TextCursorPosition`

TextPrintf

```
void TextPrintf(struct windowFrame *window, char *fmt, ...);
```

DESCRIPTION

Prints a formatted string (much like `printf`) on the LCD screen. Only printable characters in the font set are printed; escape sequences `\r` and `\n` are also recognized. All other escape sequences will be skipped over; for example, `\b` and `\t` will cause nothing to be displayed.

The text window feature provides end-of-line wrapping and clipping after the character in the last column and row is displayed. The cursor then remains at the end of the string.

NOTE: Execute the `TextWindowFrame()` function before using this function.

PARAMETERS

<code>window</code>	a pointer to a font descriptor.
<code>fmt</code>	a pointer to a formatted string.
<code>...</code>	formatted string conversion parameter(s).

EXAMPLE

```
TextPrintf(&TextWindow, "Test %d\n", count);
```

RETURN VALUE

None.

SEE ALSO

`TextGotoXY`, `TextPutChar`, `TextWindowFrame`, `TextCursorPosition`

TextMaxChars

```
int TextMaxChars(windowFrame *wPtr);
```

DESCRIPTION

This function returns the maximum number of characters that can be displayed within the text window.

NOTE: Execute the `TextWindowFrame()` function before using this function.

PARAMETER

`wPtr` a pointer to the window frame descriptor.

RETURN VALUE

The maximum number of characters that can be displayed within the text window.

SEE ALSO

`TextGotoXY`, `TextPrintf`, `TextWindowFrame`, `TextCursorPosition`

TextWinClear

```
void TextWinClear(windowFrame *wPtr);
```

DESCRIPTION

This function clears the entire area within the specified text window.

NOTE: Execute the `TextWindowFrame()` function before using this function.

PARAMETERS

`wPtr` a pointer to the window frame descriptor.

RETURN VALUE

None.

SEE ALSO

`TextGotoXY`, `TextPrintf`, `TextWindowFrame`, `TextCursorPosition`

C.8.4 Keypad

The functions used to control the keypad are contained in the Dynamic C `LIB\KEYPADS\KEYPAD7.LIB` library.

`keyInit`

```
void keyInit(void);
```

DESCRIPTION

Initializes keypad process.

RETURN VALUE

None.

SEE ALSO

`brdInit`

keyConfig

```
void keyConfig(char cRaw, char cPress, char cRelease,  
               char cCntHold, char cSpdLo, char cCntLo, char cSpdHi);
```

DESCRIPTION

Assigns each key with keypress and release codes, and hold and repeat ticks for auto repeat and debouncing.

PARAMETERS

cRaw a raw key code index.

1 × 7 keypad matrix with raw key code index assignments (in brackets):

[0]	[1]	[2]	[3]
[4]	[5]	[6]	

User Keypad Interface

cPress a keypress code

An 8-bit value is returned when a key is pressed.

0 = Unused.

See **keypadDef ()** for default press codes.

cRelease a key release code.

An 8-bit value is returned when a key is pressed.

0 = Unused.

cCntHold a hold tick, which is approximately one debounce period or 5 μs.

How long to hold before repeating.

0 = No Repeat.

cSpdLo a low-speed repeat tick, which is approximately one debounce period or 5 μs.

How many times to repeat.

0 = None.

cCntLo a low-speed hold tick, which is approximately one debounce period or 5 μs.

How long to hold before going to high-speed repeat.

0 = Slow Only.

cSpdHi a high-speed repeat tick, which is approximately one debounce period or 5 μs.

How many times to repeat after low speed repeat.

0 = None.

keyConfig (continued)

RETURN VALUE

None.

SEE ALSO

`keyProcess`, `keyGet`, `keypadDef`

keyProcess

```
void keyProcess(void);
```

DESCRIPTION

Scans and processes keypad data for key assignment, debouncing, press and release, and repeat.

NOTE: This function is also able to process an 8×8 matrix keypad.

RETURN VALUE

None.

SEE ALSO

`keyConfig`, `keyGet`, `keypadDef`

keyGet

```
char keyGet(void);
```

DESCRIPTION

Get next keypress.

RETURN VALUE

The next keypress, or 0 if none.

SEE ALSO

`keyConfig`, `keyProcess`, `keypadDef`

keyUnget

```
int keyUnget(char cKey);
```

DESCRIPTION

Pushes the value of **cKey** to the top of the input queue, which is 16 bytes deep.

PARAMETER

cKey

RETURN VALUE

None.

SEE ALSO

`keyGet`

keypadDef

```
void keypadDef();
```

DESCRIPTION

Configures the physical layout of the keypad with the desired ASCII return key codes.

1 × 7 keypad physical mapping:

0	4	1	5	2	6	3
['L']		['U']		['D']		['R']
	['-']		['+']		['E']	

where

- 'L' represents Left Scroll
- 'U' represents Up Scroll
- 'D' represents Down Scroll
- 'R' represents Right Scroll
- '-' represents Page Down
- '+' represents Page Up
- 'E' represents the ENTER key

Example: Do the following for the above physical vs. ASCII return key codes.

```
keyConfig ( 3, 'R', 0, 0, 0, 0, 0 );  
keyConfig ( 6, 'E', 0, 0, 0, 0, 0 );  
keyConfig ( 2, 'D', 0, 0, 0, 0, 0 );  
keyConfig ( 4, '-', 0, 0, 0, 0, 0 );  
keyConfig ( 1, 'U', 0, 0, 0, 0, 0 );  
keyConfig ( 5, '+', 0, 0, 0, 0, 0 );  
keyConfig ( 0, 'L', 0, 0, 0, 0, 0 );
```

Characters are returned upon keypress with no repeat.

RETURN VALUE

None.

SEE ALSO

`keyConfig`, `keyGet`, `keyProcess`

keyScan

```
void keyScan(char *pcKeys);
```

DESCRIPTION

Writes "1" to each row and reads the value. The position of a keypress is indicated by a zero value in a bit position.

PARAMETER

pcKeys a pointer to the address of the value read.

RETURN VALUE

None.

SEE ALSO

keyConfig, keyGet, keypadDef, keyProcess

APPENDIX D. POWER SUPPLY

Appendix D provides information on the current requirements of the RCM3900, and includes some background on the chip select circuit used in power management.

D.1 Power Supplies

Power is supplied from the motherboard to which the RCM3900 is connected via header J62. The RCM3900 requires a regulated 3.15 V to 3.45 V DC power source. An RCM3900 with no loading at the outputs operating at 44.2 MHz typically draws 350 mA.

D.1.1 Battery Backup

The RCM3900 does not have a battery, but there is provision for a customer-supplied battery to back up the data SRAM and keep the internal Rabbit 3000 real-time clock running.

Header J62, shown in Figure D-1, allows access to the external battery. This header makes it possible to connect an external 3 V power supply. This allows the SRAM and the internal Rabbit 3000 real-time clock to retain data with the RCM3900 powered down.

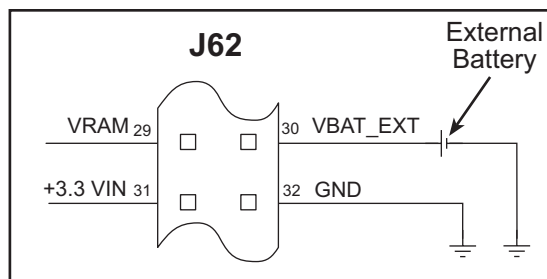

Figure D-1. External Battery Connections at Header J62

A lithium battery with a nominal voltage of 3 V and a minimum capacity of 165 mA·h is recommended. A lithium battery is strongly recommended because of its nearly constant nominal voltage over most of its life.

The drain on the battery by the RCM3900 is typically 6 μ A when no other power is supplied. If a 235 mA·h battery is used, the battery can last about 4.5 years:

$$\frac{235 \text{ mA}\cdot\text{h}}{6 \mu\text{A}} = 4.5 \text{ years.}$$

The actual battery life in your application will depend on the current drawn by components not on the RCM3900 and the storage capacity of the battery. The RCM3900 does not drain the battery while it is powered up normally.

Cycle the main power off/on after you install a backup battery for the first time, and whenever you replace the battery. This step will minimize the current drawn by the real-time clock oscillator circuit from the backup battery should the RCM3900 experience a loss of main power.

NOTE: Remember to cycle the main power off/on any time the RCM3900 is removed from the Prototyping Board or motherboard since that is where the backup battery would be located.

Rabbit's Technical Note TN235, *External 32.768 kHz Oscillator Circuits*, provides additional information about the current draw by the real-time clock oscillator circuit.

D.1.2 Battery-Backup Circuit

Figure D-2 shows the battery-backup circuit.

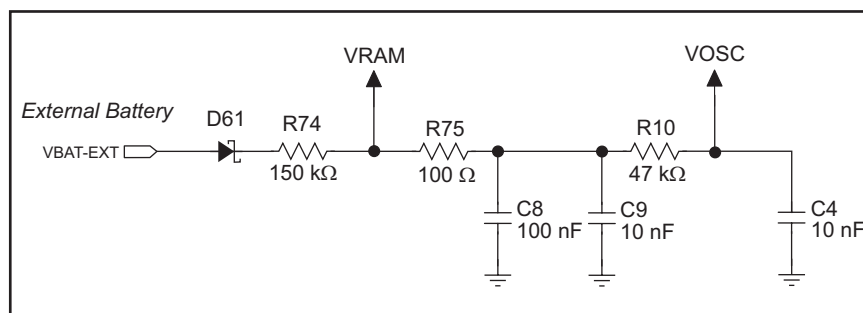

Figure D-2. RCM3900 Backup Battery Circuit

The battery-backup circuit serves three purposes:

- It reduces the battery voltage to the SRAM and to the real-time clock, thereby limiting the current consumed by the real-time clock and lengthening the battery life.
- It ensures that current can flow only *out* of the battery to prevent charging the battery.
- A voltage, VOSC, is supplied to U5, which keeps the 32.768 kHz oscillator working when the voltage begins to drop.

D.1.3 Reset Generator

The RCM3900 uses a reset generator to reset the Rabbit 3000 microprocessor when the voltage drops below the voltage necessary for reliable operation. The reset occurs between 2.85 V and 3.00 V, typically 2.93 V.

The RCM3900 has a reset pin, pin 36 on header J1. This pin provides access to the reset output from the reset generator, and is also connected to the reset input of the Rabbit 3000 to allow you to reset the microprocessor externally. A resistor divider consisting of R22 and R23 attenuates the signal associated with an externally applied reset to prevent it from affecting the reset generator.

INDEX

Symbols

/IOWR
loading 28

A

additional information
online documentation 7

B

battery backup
battery life 160
circuit 160
external battery connections 159
use of battery-backed SRAM
..... 42
board initialization
function calls 45
brdInit() 45
bus loading 73

C

clock doubler 38
conformal coating 78
connectivity interface kits
Connector Adapter Board ... 7
Connector Adapter Board 7

D

Development Kit 6
512 MB miniSD™ Card 6
AC adapter 6
DC power supply 6
Getting Started instructions 6
programming cable 6

digital I/O 24
function calls
digIn() 46
digOut() 47
I/O buffer sourcing and sinking limits 77
memory interface 29
SMODE0 32
SMODE1 32

digital inputs
switching threshold 90

dimensions
LCD/keypad module 103
LCD/keypad template 106
Prototyping Board 85
RCM3900 68

Dynamic C 7, 9, 39
add-on modules 9, 52
installation 9
battery-backed SRAM 42
FAT file system 43, 44
libraries

RCM39xx.LIB 45
SDFLASH.LIB 44
protected variables 42
Rabbit Embedded Security
Pack 7, 9, 52
sample programs 16
standard features
debugging 40
telephone-based technical
support 7, 52
upgrades and patches 52

E

Ethernet cables 53
how to tell them apart 53
Ethernet connections 53, 55
10/100-compatible 55
10Base-T Ethernet card ... 53
additional resources 66
direct connection 55

IP addresses 55, 57
MAC addresses 58
steps 54
Ethernet port 31
function calls
pd_powerdown() 31
pd_powerup() 31
pinout 31
powerdown 31
exclusion zone 69
external I/O bus
software 42

F

features 2
comparison with RCM3365/
RCM3375 4
Prototyping Board 82, 83
flash memory addresses
user blocks 35

H

hardware connections
install RCM3900 on Prototyping Board 10
power supply 12
programming cable 11
hardware reset 12
headers
Prototyping Board
JP3 92, 93
JP5 95

I

I/O address assignments
LCD/keypad module 107
I/O buffer sourcing and sinking
limits 77
IP addresses 57
how to set in sample programs
62
how to set PC IP address .. 63

J

- jumper configurations
 - Prototyping Board
 - JP1 (stepper motor power supply)99
 - JP2 (stepper motor power supply)99
 - JP3 (quadrature decoder/serial flash)99
 - JP4 (RCM3900 power supply)99
 - JP5 (RS-485 bias and termination resistors) ...95, 99
 - stepper motor power supply97
 - RCM390079
 - JP1 (not stuffed)79
 - JP10 (PD3 or TPO+ output on J61 pin 30)80
 - JP11 (flash memory size)80
 - JP12 (flash memory bank select)35, 80
 - JP13 (data SRAM size) .80
 - JP14 (LED DS1 display) 80
 - JP2 (ACT or PD1 output on J61 pin 34)79
 - JP3 (LINK or PD0 output on J61 pin 33)79
 - JP4 (ENET or PE0 output on J62 pin 19)79
 - JP5 (NAND flash chip enable)79
 - JP7 (PD6 or TPO- input on J61 pin 31)80
 - JP8 (PD7 or TPI+ input on J61 pin 32)80
 - JP9 (PD2 or TPO- output on J61 pin 29)80
 - jumper locations79

K

- keypad template106
 - removing and inserting label106

L

- LCD/keypad module
 - bezel-mount installation ..109
 - dimensions103
 - function calls
 - dispInit()113
 - header pinout107
 - I/O address assignments ..107
 - keypad
 - function calls
 - keyConfig()152
 - keyGet()154
 - keyInit()151
 - keypadDef()156
 - keyProcess()154
 - keyScan()157
 - keyUnget()155
 - keypad template106
 - LCD display
 - function calls
 - glBackLight()115
 - glBlankRegion()120
 - glBlankScreen()117
 - glBlock()121
 - glBuffLock()131
 - glBuffUnlock()131
 - glDispOnOff()116
 - glDown1()139
 - glFastFillRegion()119
 - glFillCircle()125
 - glFillPolygon()124
 - glFillRegion()118
 - glFillScreen()117
 - glFillVPolygon()123
 - glFontCharAddr()127
 - glGetBrushType()133
 - glGetPfStep()128
 - glHScroll()140
 - glInit()115
 - glLeft1()136
 - glPlotCircle()125
 - glPlotDot()135
 - glPlotLine()135
 - glPlotPolygon()122
 - glPlotVPolygon()121
 - glPrintf()130
 - glPutChar()129
 - glPutFont()127
 - glRight1()137
 - glSetBrushType()132

- glSetContrast()116
- glSetPfStep()128
- glSwap()132
- glUp1()138
- glVScroll()141
- glXFontInit()126
- glXGetBitmap()133
- glXGetFastmap()134
- glXPutBitmap()142
- glXPutFastmap()143
- TextBorder()146
- TextBorderInit()145
- TextCursorLocation()
.....147
- TextGotoXY()146
- TextMaxChars()150
- TextPrintf()149
- TextPutChar()148
- TextWinClear()150
- TextWindowFrame() 144

LEDs

- function calls114
 - displedOut()114
- mounting instructions108
- reconfigure keypad106
- remote cable connection ..111
- removing and inserting keypad label106
- sample programs112
- specifications104
- versions103
- voltage settings105

LED (Prototyping Board)

- function calls
 - ledOut()49

M

- MAC addresses58
- miniSD™ Card
 - adapter37
 - formatting44
 - programming external LED37
 - software
 - SDFLASH.LIB44
 - use in mass-storage application44
 - use with SD Card reader ...37
- mounting instructions
 - LCD/keypad module108

P			
pinout			
Ethernet port	31	
LCD/keypad module	107	
RCM3900			
alternate configurations	..	26	
RCM3900 headers	24	
power supplies			
+3.3 V	159	
battery backup	159	
Program Mode	33	
switching modes	33	
programming cable			
PROG connector	33	
RCM3900 connections	11	
programming port	32	
Prototyping Board	82	
adding components	89	
dimensions	85	
expansion area	83	
features	82, 83	
jumper configurations	99	
jumper locations	98	
mounting RCM3900	10	
power supply	87	
prototyping area	89	
specifications	86	
use of parallel ports	100	
R			
Rabbit 3000			
data and clock delays	75	
spectrum spreader time delays	75	
Rabbit subsystems	25	
RabbitNet			
RabbitNet port	95	
RCM3900			
comparison with RCM3365/ RCM3375	4	
LEDs	29	
mounting on Prototyping Board	10	
relay			
function calls			
relayOut()	50	
remote programming	41	
download manager	41	
RabbitLink	41	
reset	12	
reset generator	161	
use of reset pin	161	
RS-485 network			
termination and bias resistors	95	
Run Mode	33	
switching modes	33	
S			
sample programs	16	
download manager			
DLM_TCP.C	41	
DLP_TCP.C	41	
getting to know the RCM3900			
CONTROLLEDS.C	16	
FLASHLEDS.C	16	
SWRELAY.C	16	
TOGGLESWITCH.C	16	
how to run TCP/IP sample programs	61, 62	
how to set IP address	62	
LCD/keypad module	..	21, 112	
KEYBASIC.C	106	
KEYPADTOLED.C	112	
LCDKEYFUN.C	112	
reconfigure keypad	106	
SWITCHTOLCD.C	112	
miniSD™ Card			
SDFLASH_INSPECT.C	19		
SDFLASH_LOG.C	19	
NAND flash			
NFLASH_DUMP.C	17	
NFLASH_ERASE.C	17	
NFLASH_INSPECT.C	..	17	
NFLASH_LOG.C	17	
PONG.C	13	
real-time clock			
RTC_TEST.C	21	
SETRTCKB.C	21	
serial communication			
FLOWCONTROL.C	19	
PARITY.C	20	
SIMPLE3WIRE.C	20	
SIMPLE485MASTER.C	21		
SIMPLE485SLAVE.C	..	21	
SIMPLE5WIRE.C	20	
SWITCHCHAR.C	20	
TCP/IP			
BROWSELED.C	64	
DISPLAY_MAC.C	58	
MBOXDEMO.C	64	
PINGLED.C	64	
PINGME.C	64	
RabbitWeb			
BLINKLEDS.C	65	
DOORMONITOR.C	..	65	
SPRINKLER.C	65	
SMTP.C	65	
user-programmable LED			
CONTROLLEDS.C	29	
FLASHLEDS.C	29	
SD Card adapter	37	
serial communication	30	
function calls			
ser485Rx()	51	
ser485Tx()	51	
Prototyping Board			
RS-232	93	
RS-485 termination and bias resistors	95	
serial port configura- tions	92	
RabbitNet port	95	
serial ports	30	
Ethernet port	31	
programming port	32	
software	7	
external I/O bus	42	
I/O drivers	42	
libraries			
KEYPAD7.LIB	151	
LCD122KEY7.LIB	113, 114	
NAND flash	43	
PACKET.LIB	43	
RS232.LIB	18, 43, 44	
SDFLASH.LIB	44	
TCP/IP	43	
miniSD™ Card	44	
NAND flash drivers	43	
power down Ethernet chip	31		
serial communication drivers	43	
TCP/IP drivers	43	

specifications	67
bus loading	73
digital I/O buffer sourcing and sinking limits	77
dimensions	68
electrical, mechanical, and environmental	70
exclusion zone	69
header footprint	72
headers	72
LCD/keypad module	
dimensions	103
electrical	104
header footprint	104
mechanical	104
relative pin 1 locations	104
temperature	104
Prototyping Board	86
Rabbit 3000 DC characteris- tics	76
Rabbit 3000 timing diagram	74
relative pin 1 locations	72
spectrum spreader	75
settings	38
subsystems	
digital inputs and outputs ..	24
switches	
function calls	
switchIn()	48
switching modes	33

T

TCP/IP primer	55
technical support	14
troubleshooting	
connections	13

U

user block	
function calls	
readUserBlock()	35
writeUserBlock()	35



SCHEMATICS

090-0253 RCM3900 Schematic

www.rabbit.com/documentation/schemat/090-0253.pdf

090-0188 Prototyping Board Schematic

www.rabbit.com/documentation/schemat/090-0188.pdf

090-0156 LCD/Keypad Module Schematic

www.rabbit.com/documentation/schemat/090-0156.pdf

090-0252 USB Programming Cable Schematic

www.rabbit.com/documentation/schemat/090-0252.pdf

You may use the URL information provided above to access the latest schematics directly.

