

Quick Start Guide

1. Install Dynamic C and remaining Wireless Control Application Kit software.
2. Attach the LP3500 to Prototyping Board, connect programming cable to PC, connect AC adapter.
3. Set up the XCite™ wireless data module and attach it to the RS-232/RS-485 Interface Board.
4. Configure your PC and network connections for the sample programs you will be running.
5. Explore the sample programs in the Dynamic C `SAMPLES\WirelessControl` folder. There is also a ModbusMaster application to demonstrate wireless control described in these *Getting Started* instructions.

Wireless Control Application Kit (900 MHz XCite™ RF Modules)

The Wireless Control Application Kit highlights the interface of MaxStream's 900 MHz XCite™ wireless data modules with one of Rabbit Semiconductor's single-board computers, the LP3500. The Wireless Control Application Kit comes with sample programs that illustrate the simple configuration and control of a new or existing Rabbit-based embedded system via a wireless interface using either the Modbus protocol or a direct point-to-point protocol (PPP) serial connection with a Web browser.

Application Kit Contents

- 5 CD-ROMs — *Dynamic C*® with complete product documentation on disk, Dynamic C RabbitWeb module, Dynamic C Point-to Point Protocol (PPP) module, Dynamic C Modbus module, and supplemental CD with sample programs and information related to the Wireless Control Application Kit.
- LP3500 single-board computer.
- LP3500 Prototyping Board with pushbutton switches, LEDs, and screw-terminal headers.
- 2 MaxStream 900 MHz XCite™ wireless data modules.
- 2 MaxStream RS-232/RS-485 Interface Boards for use with MaxStream XCite™ wireless data modules.
- 3 AC adapters — one 12 V DC, 1 A, for use with LP3500 module and Prototyping Board, two 9 V DC, 400 mA for use with MaxStream 900 MHz XCite™ wireless data modules.
- Programming cable with 10-pin header and DB9 connections, and level-matching adapter board.
- 2 serial cables — one DB9F to DB9M, one DB9M to bare wire leads.
- Four standoff with mounting screws.
- *Getting Started* instructions.
- *Rabbit 3000 Processor Easy Reference* poster.
- MaxStream catalog.
- Registration card.

Installing Dynamic C®

Insert the Dynamic C CD from the Application Kit in your PC's CD-ROM drive. If the installation does not auto-start, run the `setup.exe` program in the root directory of the Dynamic C CD. Install the software from the supplemental CD and any Dynamic C software modules after you install Dynamic C.

LP3500 Connections

Use the 4-40 screws to attach the metal standoffs to the LP3500 board as shown.

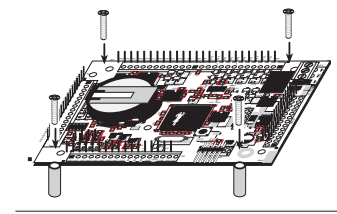

Remove Battery Tab

The backup battery on the LP3500 has a plastic tab to protect the battery against discharging before the LP3500 is placed into service. The backup battery protects the contents of the SRAM and keeps the real-time clock running when regular power to the LP3500 is interrupted.

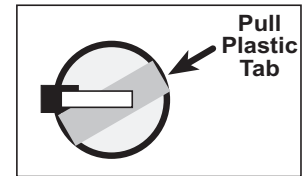

Attach LP3500 to Prototyping Board

Press the pins from the headers on the bottom side of the LP3500 firmly into the corresponding header sockets located at J1, J2, and J4 on the Prototyping Board.

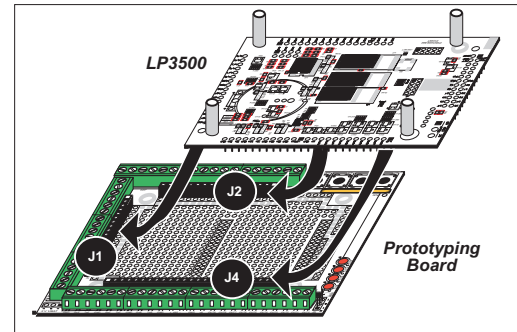

NOTE: It is important that you line up the header pins on the LP3500 exactly with the corresponding header sockets J1, J2, and J4 on the Prototyping Board. The header pins may become bent or damaged if the pin alignment is offset, and the LP3500 will not work. Permanent electrical damage may also result if a misaligned LP3500 is powered up.

Connect Programming Cable

The programming cable connects the LP3500 to the PC running Dynamic C to download programs and to monitor the LP3500 during debugging.

Connect the 10-pin connector of the programming cable labeled **PROG** to header J5 on the LP3500. Ensure that the colored edge lines up with pin 1 as shown. (Do not use the **DIAG** connector, which is used for a normal serial connection.) Connect the other PC end of the programming cable to a COM port on your PC.

NOTE: Be sure to use the programming cable (Part No. 101-0513) supplied with this Application Kit—the programming cable has red shrink wrap around the RS-232 converter section located in the middle of the cable. Programming cables from other Rabbit Semiconductor kits are not designed to work with the LP3500.

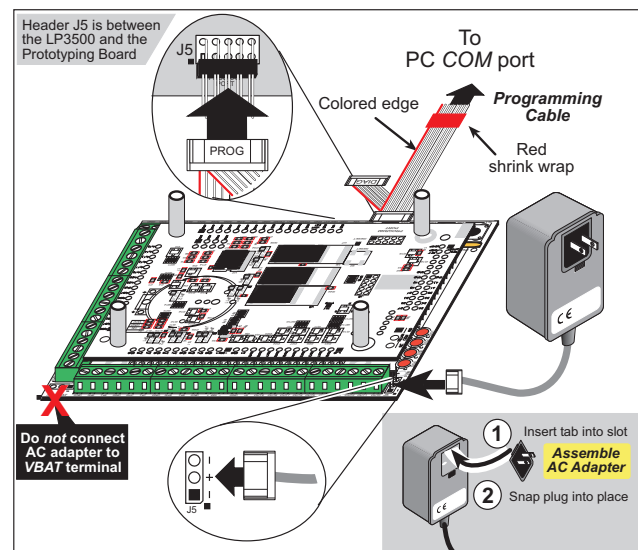

NOTE: Some PCs now come equipped only with a USB port. It may be possible to use an RS-232/USB converter (Part No. 540-0070) with the programming cable supplied with the Application Kit. Note that not all RS-232/USB converters work with Dynamic C.

Connect Power Supply

If you have the universal AC adapter, prepare the AC adapter for the country where it will be used by selecting the appropriate plug. Snap in the top of the plug assembly into the slot at the top of the AC adapter as shown, then press down on the plug until it clicks into place.

Hook up the connector from the 12 V AC adapter to header J5 on the Prototyping Board as shown above. The orientation of this connector is not important since the VIN (positive) voltage is the middle pin, and GND is available on both ends of the three-pin header J5.

NOTE: Do *not* connect the AC adapter to the **VBAT** terminal on the Prototyping Board. The **VBAT** terminal supplies the backup battery voltage of 3 V, and the LP3500 may be damaged if subjected to the raw DC voltage from the AC adapter through the **VBAT** terminal.

NOTE: A hardware reset may be done by pressing the RESET switch on the LP3500. The LP3500 may also be reset by unplugging the AC adapter, then plugging it back in. However, when the LP3500 is operating in the power-save mode, the backup battery will provide sufficient voltage to prevent a reset from happening, in which case you will have to press the RESET switch on the LP3500. Reset switches are located on both sides of the LP3500 board.

Run a Sample Program

Once the LP3500 is connected as described, start Dynamic C by double-clicking on the Dynamic C icon or by double-clicking on `dcrab_XXXX.exe` in the Dynamic C root directory, where `XXXX` are version-specific characters.

If you are using a USB port to connect your computer to the LP3500, choose **Options > Project Options** and check “Use USB to Serial Converter” in “Serial Options” on the **Communications** tab. Click **OK** to save the settings.

Use the **File** menu to open the `MODBUS_SERIAL_SLAVE.C` sample program in the Dynamic C `SAMPLES\Modbus` folder. Press function key **F9** to compile and run the program. Remove the programming cable and reset the LP3500 once the program has compiled and is running. A reset switch is located on both sides of the LP3500 near the programming header.

XCite™ Wireless Data Module Setup

1. Set the DIP switches on both RS-232/RS-485 Interface Boards to the **RS-232 Mode** [Switch 1 is ON (up) and the remaining 5 switches are OFF (down)].
2. Mount each XCite™ wireless data module to an RS-232/RS-485 Interface Board as shown at right.
3. Use the DB9F to DB9M serial cable to connect one Interface Board to your PC COM port. You may use the RS-232/USB converter (Part No. 540-0070) if your PC does not have a COM port.

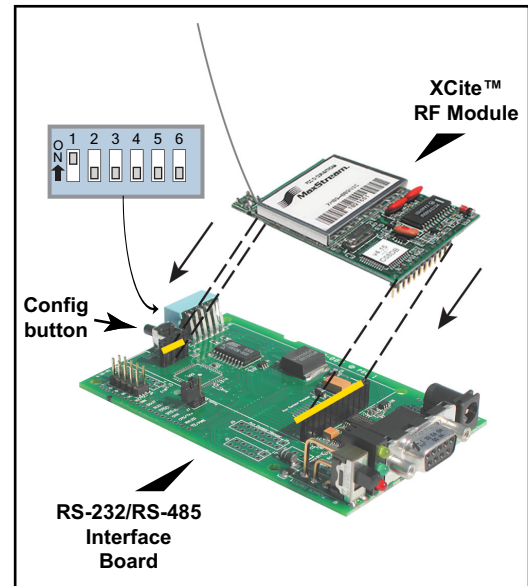
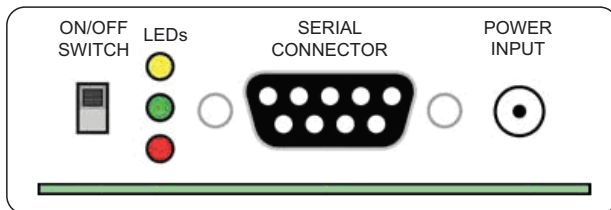

4. Locate and double-click `setup_x-ctu.exe` in the Dynamic C `DCRabbit...\X-CTU software` directory to install the X-CTU application that you will use to set up the wireless data modules.
5. Connect a 9 V AC adapter to the power input on the RS-232/RS-485 Interface Board. Use the ON/OFF switch on the RS-232/RS-485 Interface Board to turn the Interface Board on—the red LED should light up.
6. Start X-CTU from the desktop icon and set the “PC Settings” tab to **38400** baud, **NONE** flow control, **8** data bits, parity **NONE**, **1** stop bit. Click **Test/Query**, then click **OK** when you get the report “Communication with modem...OK” that displays the modem type and firmware. Note the modem type (XC09-038). The settings in this step apply only when you have a module “fresh out of the box” — otherwise use the settings in Step 8.
7. Click **Read** on the “Modem Configuration” tab. The modem type identified in the previous step should display, and you will now set the serial options specified at right. Click **Write** when you have set the serial options.
8. Now set the “PC Settings” tab to **9600** baud, **NONE** flow control, **8** data bits, parity **NONE**, **1** stop bit. Click **Test/Query**, then click **OK** when you get the report “Communication with modem...OK” that displays the modem type and firmware.

- *AT Command/Serial Interface Options*
CD – D03 Configuration = 2 - low
- *Non-AT Settable Parameters/Serial Interfacing Options*
Baud Rate = 3 - 9600
DI2 Configuration = 1 - RTS flow control

9. Turn the Interface Board OFF, then use the DB9M to bare wire leads serial cable to connect this Interface Board to header J41 on the LP3500 Prototyping Board. Turn the Interface Board back ON.
10. Connect the other Interface Board to your PC COM port (see Step 3) and repeat Steps 5–8. Leave this Interface Board connected to your PC.

After you place the Interface Board connected to the LP3500 some distance away from the PC workstation, you will be able to try to control the LP3500 wirelessly from the PC workstation.

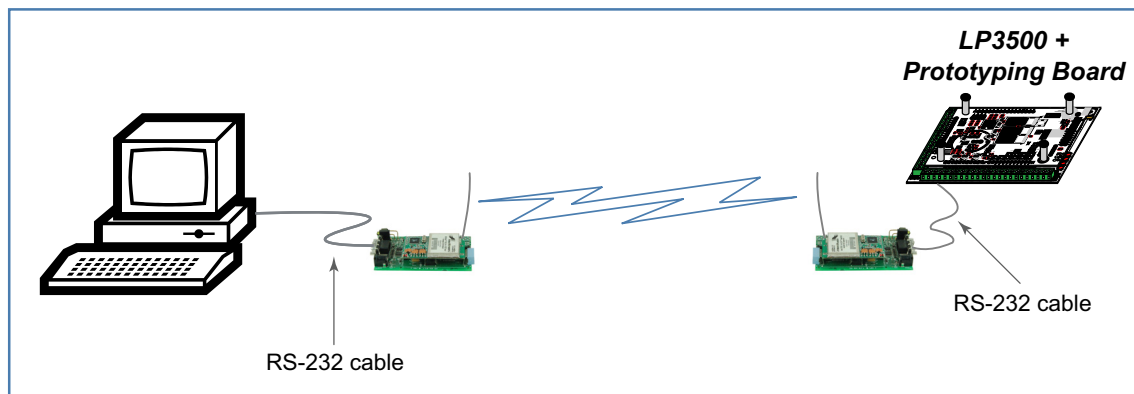
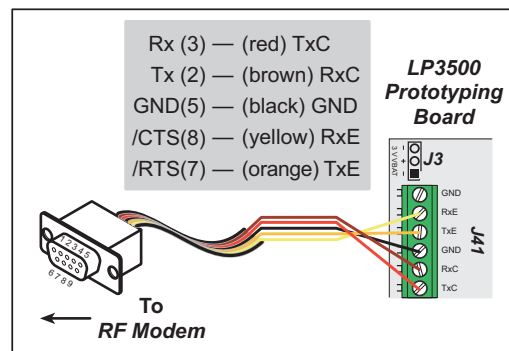

Wireless Control Demonstration

Start the ModbusMaster application that you installed from the supplemental CD — double-click the **Modbus - Master .exe** file in the Dynamic C **Modbus** folder. Select the LP3500 from the **Board** pulldown menu, then select your choice of any of DigOut 0 to DigOut 3. The corresponding LEDs on the LP3500 Prototyping Board will light up once you click “Update Digital Outputs.”

Where Do I Go From Here?

You are now ready to go on to other sample programs and to develop your own applications. Application Note AN414, *Wireless Control Application Kit*, takes you through loading and using the sample programs included with the supplemental CD, and references additional resources on wireless communications. The **LP3500 User's Manual** provides complete hardware reference information, and describes the software function calls for the LP3500 and the Prototyping Board. These documents and additional information about the XCite™ wireless data modules and their use and specifications can be accessed via the documentation page that was installed from the supplemental CD on your PC desktop.

Visit www.rabbit.com/products/rohs/products.shtml for information on RoHS and PCB colors.

Troubleshooting

- Use the Dynamic C **Help** menu to get further assistance with Dynamic C.
- Remember to reconfigure the wireless data modules for the PPP sample programs as described in AN414.
- Check the Rabbit Semiconductor Technical Bulletin Board and forums at www.rabbit.com/support/bb/ and at www.rabbit.com/forums/.
- Use the Technical Support e-mail form at www.rabbit.com/support/questionSubmit.shtml.

NOTE: If you purchased your Wireless Control Application Kit through a distributor or through a Rabbit Semiconductor partner, contact the distributor or partner first for technical support.