

ConnectCore 6UL Single Board Computer PRO

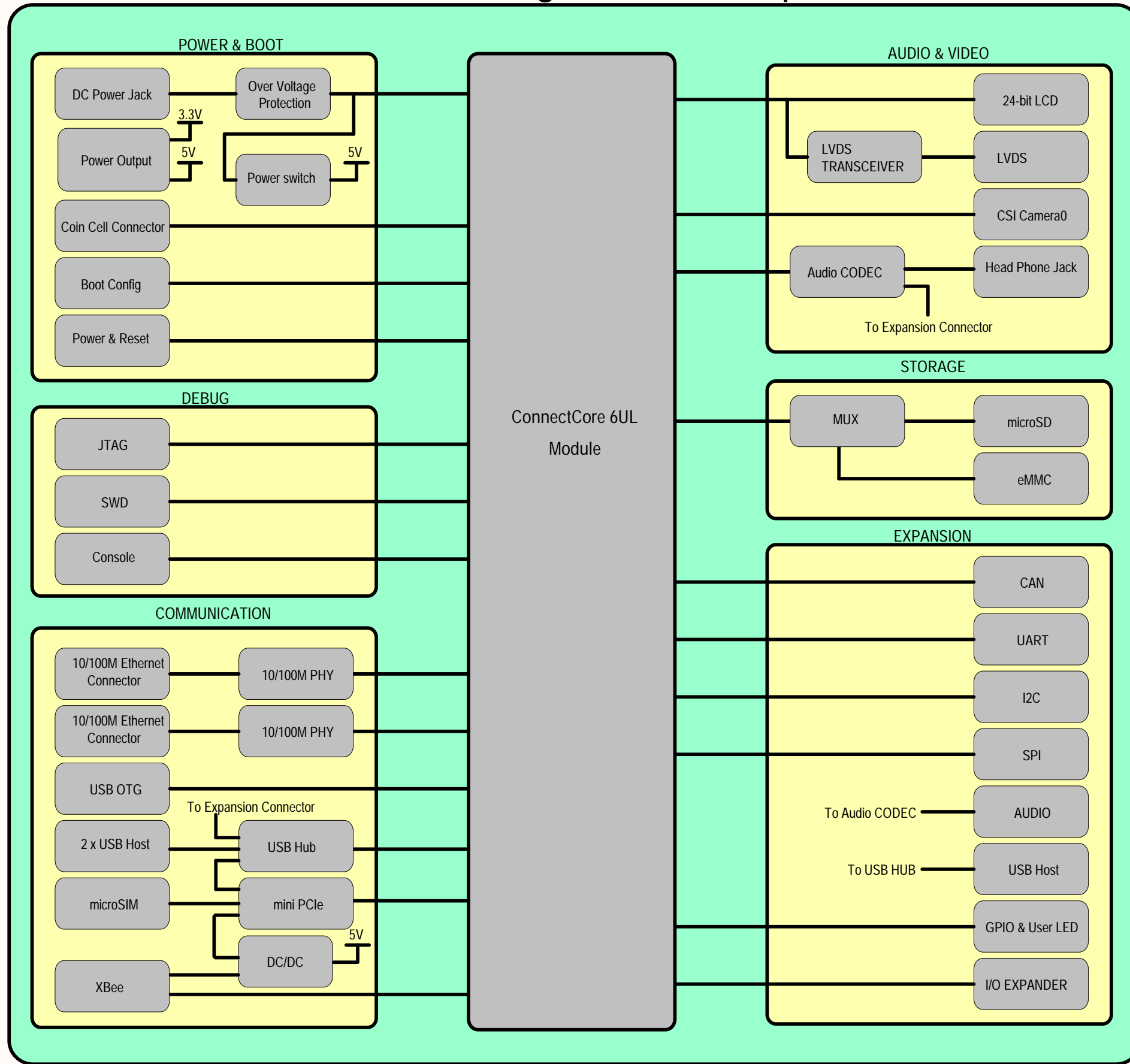
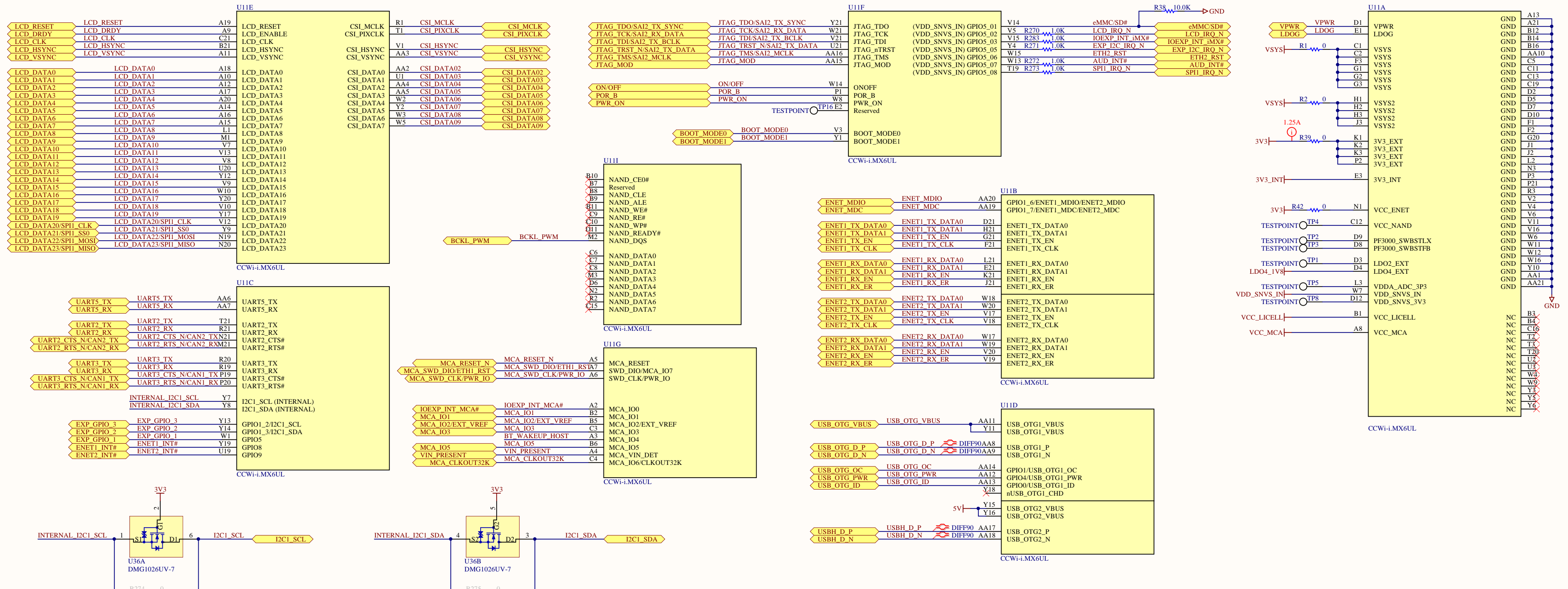

Table of Content

Page	Name
Page 1	Block Diagram
Page 2	ConnectCore for i.MX6UL Module
Page 3	Power, boot strap, reset
Page 4	MicroSD/eMMC, mini PCIe, microSIM
Page 5	JTAG, SWD, Console, UART, I/O expander
Page 6	Dual 10/100M Ethernet
Page 7	USB OTG, USB HUB, USB Host
Page 8	Displays, Camera
Page 9	Audio
Page 10	CAN, I2C, XBee
Page 11	Expansion Connectors and User LEDs
Page 12	Bootstrap
Page 13	GPIO Table, System Power Rails
Page 14	History, Mechanical

ConnectCore for i.MX6UL Module



RF

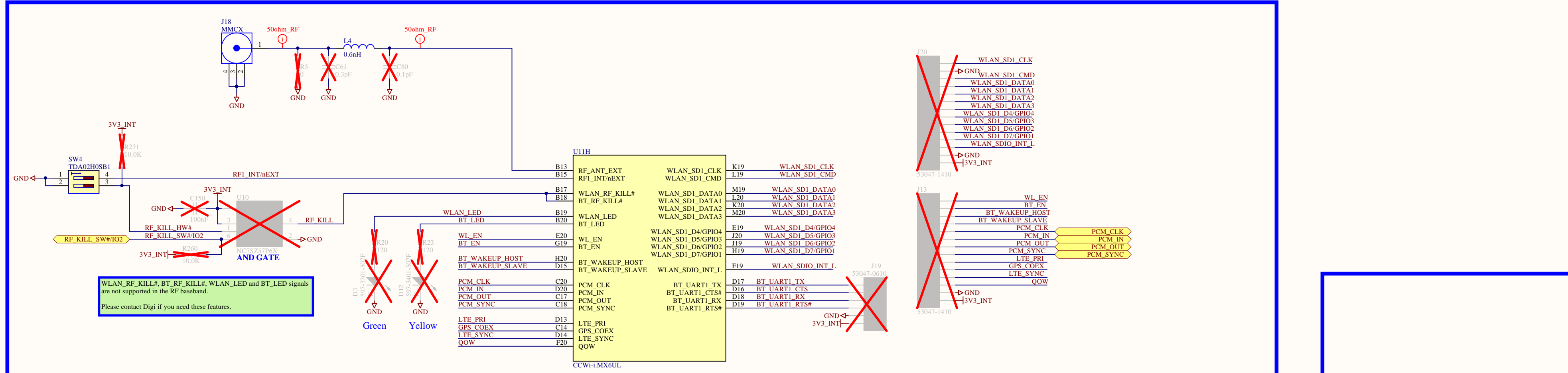

Power and Reset

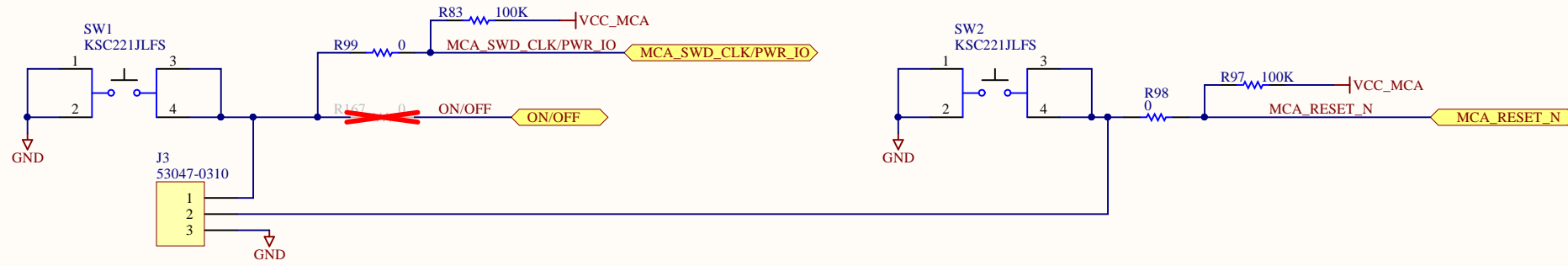

Supply Inputs

Over Voltage Protection

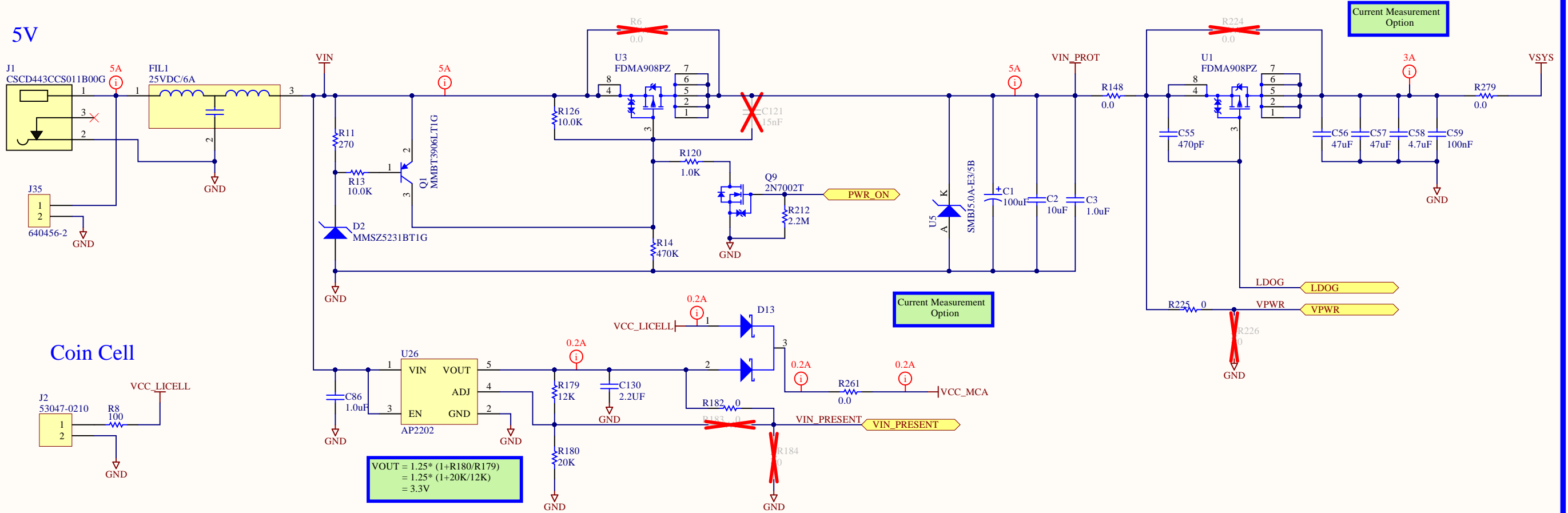

5V Load switch

Supply Outputs

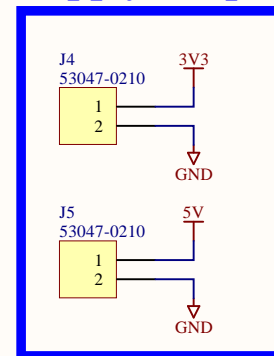
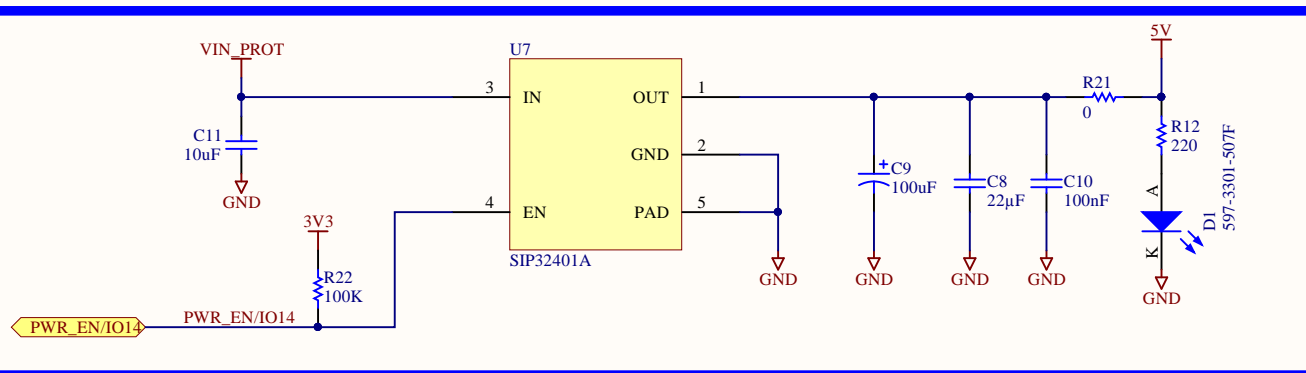

PCIe power supply

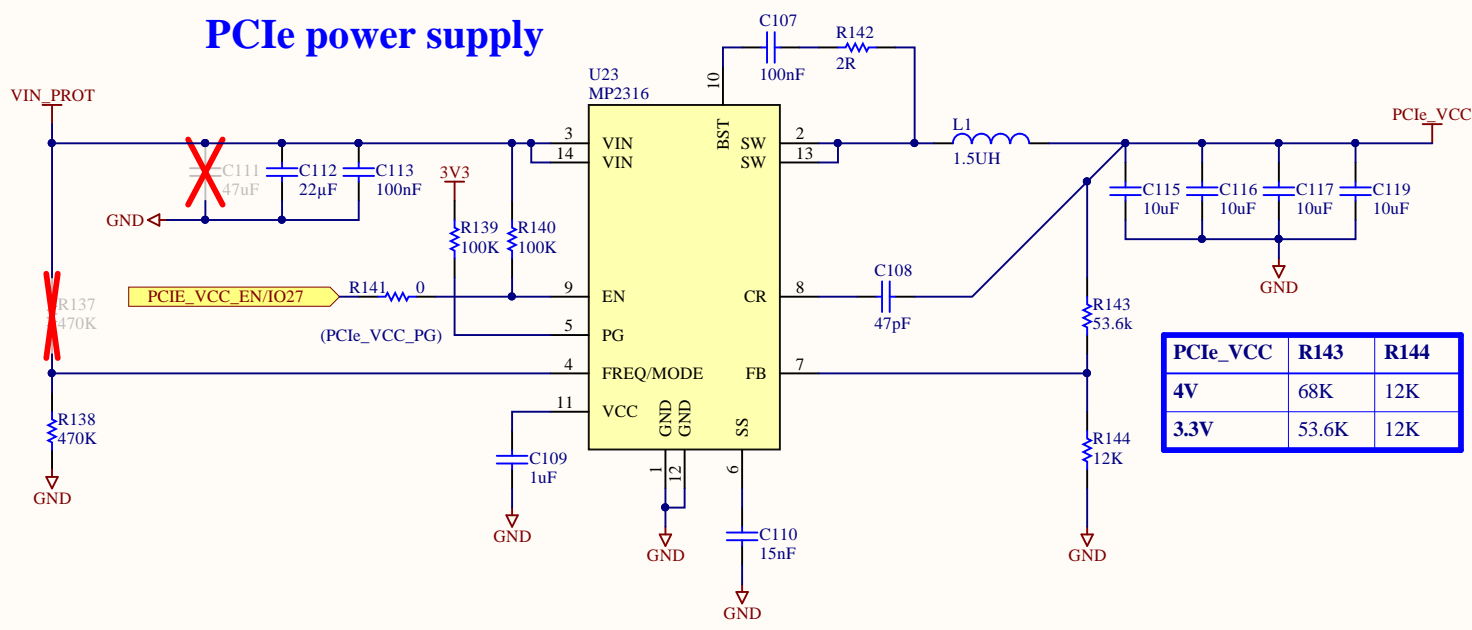

miniPCIe

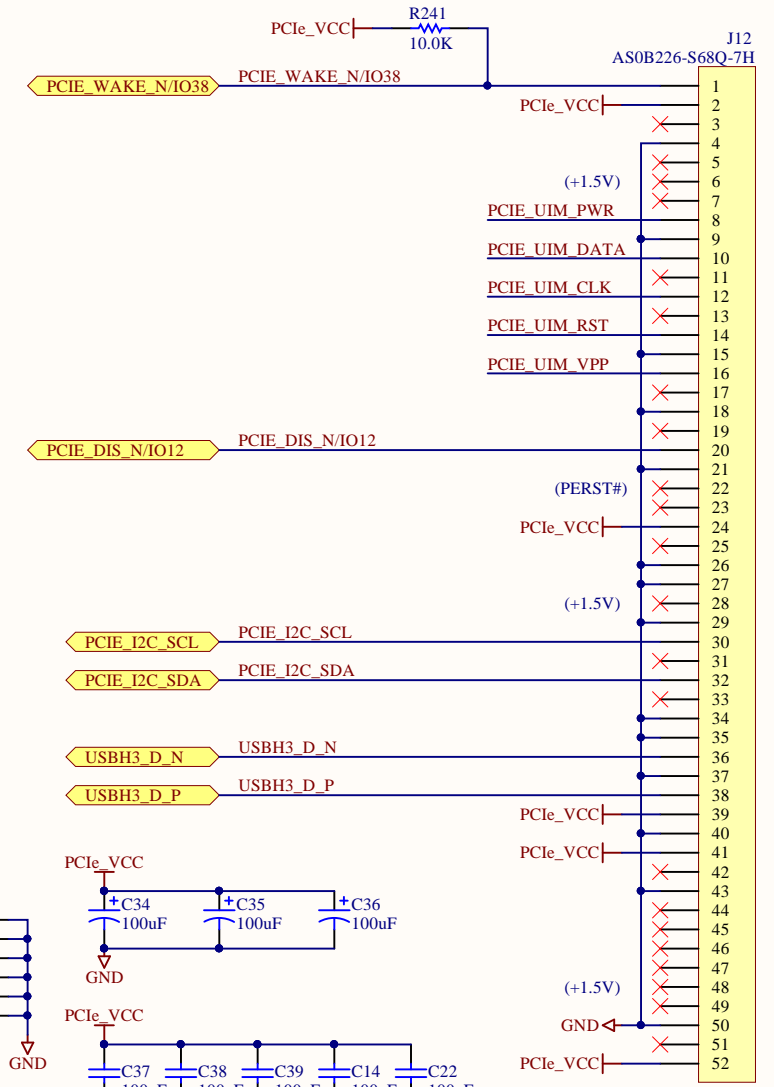

micro SIM

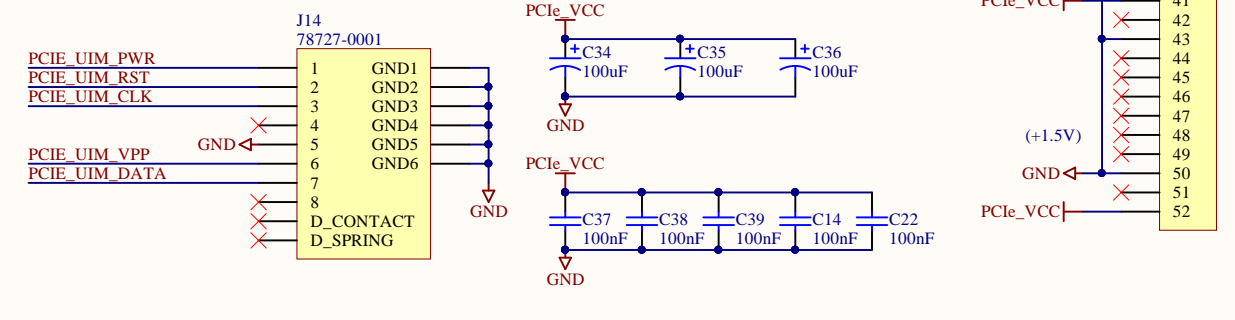

eMMC

microSD

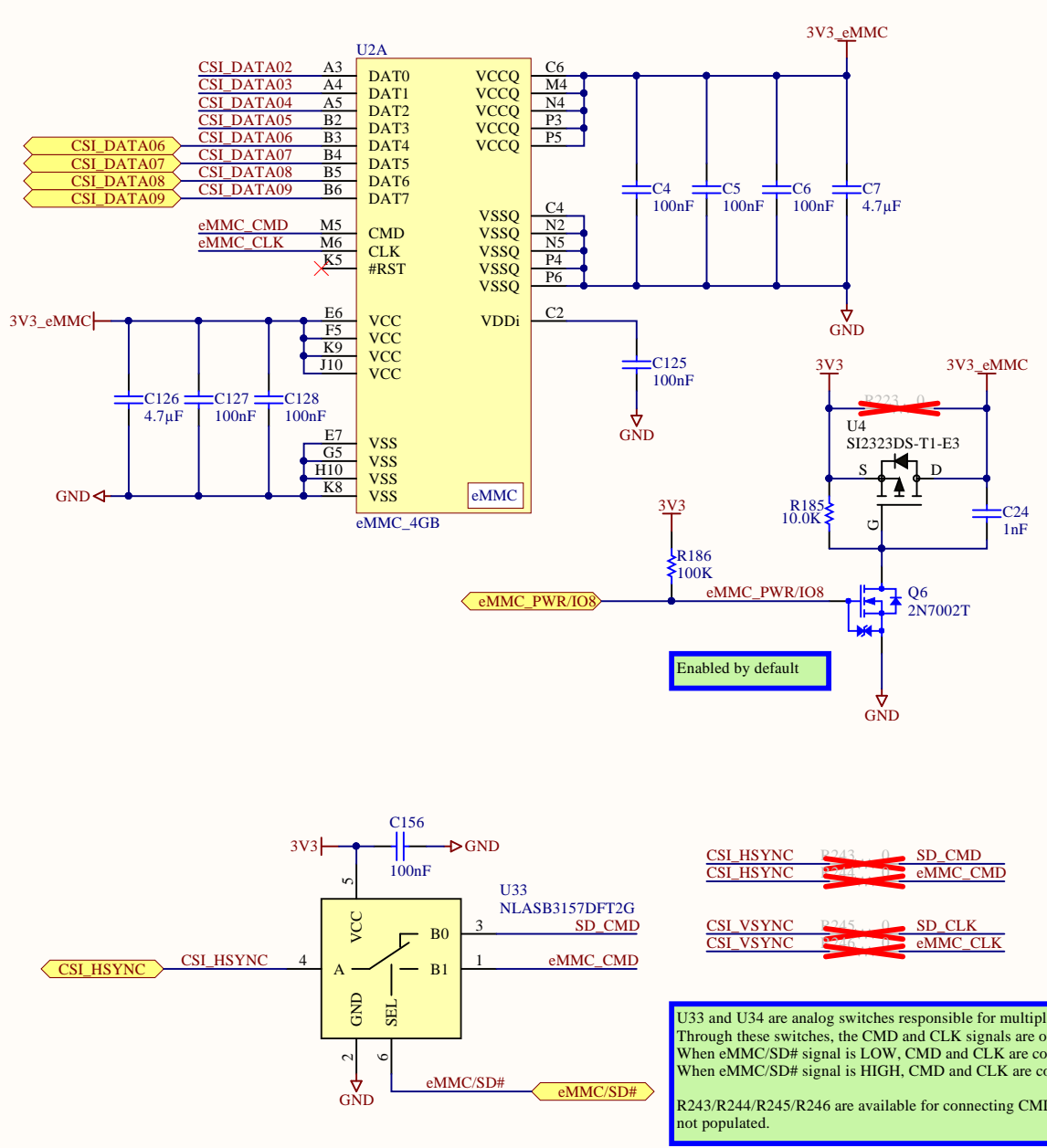

U33 and U34 are analog switches responsible for multiplexing SD2_CMD and SD2_CLK signals. Through these switches, the CMD and CLK signals are only available on one device at a time. When eMMC/SD# signal is LOW, CMD and CLK are connected to microSD card socket (J7). When eMMC/SD# signal is HIGH, CMD and CLK are connected to eMMC chip (U2).

R243/R244/R245/R246 are available for connecting CMD and CLK signals when analog switches are not populated.

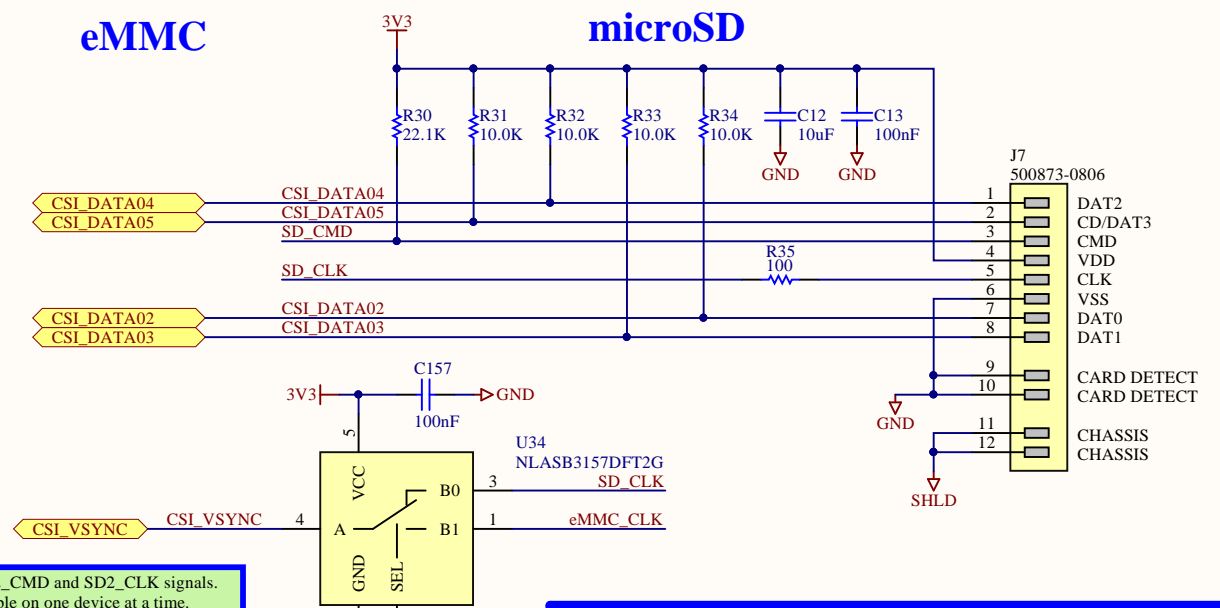

I/O EXPANDER

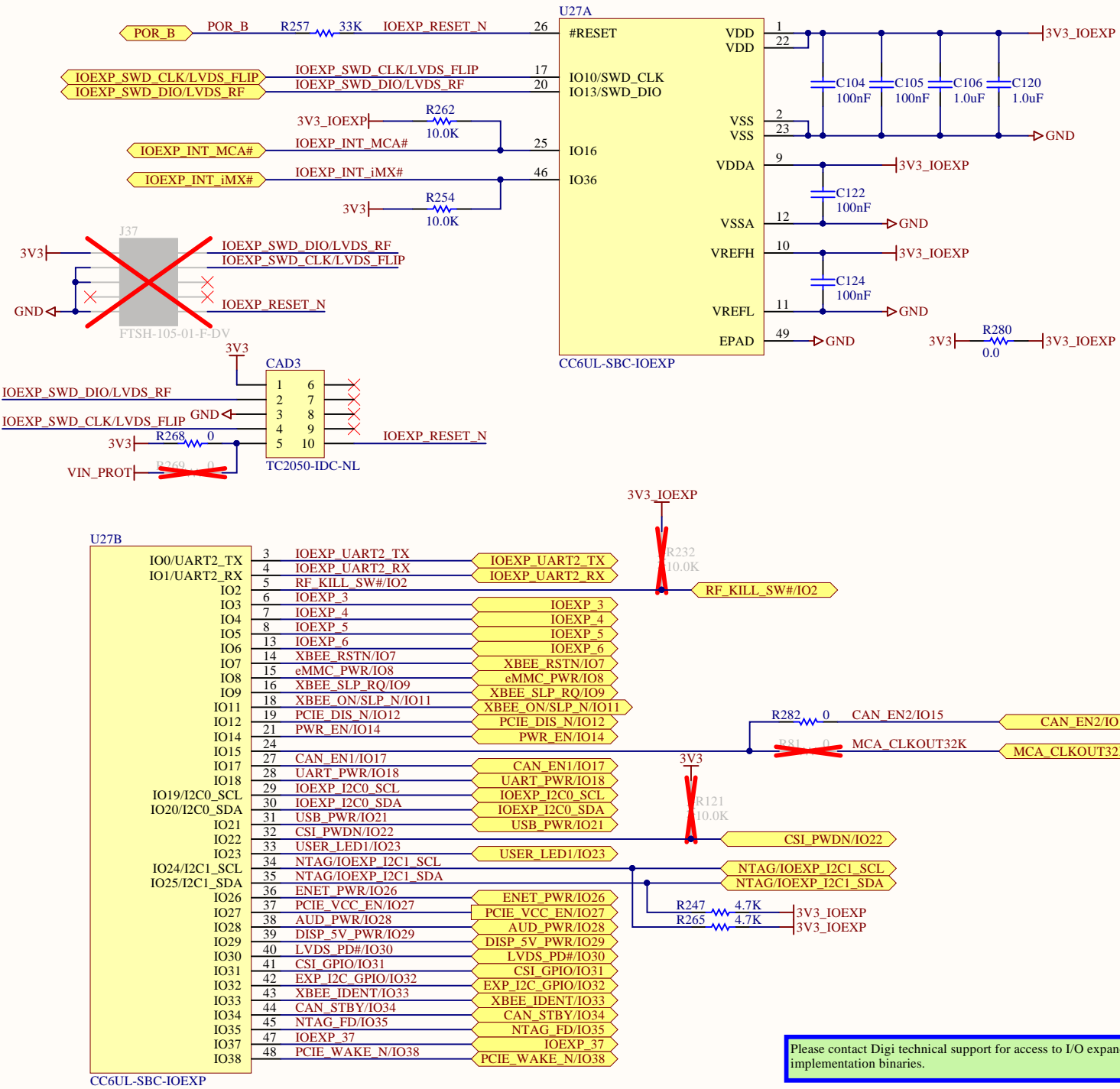

Please contact Digi technical support for access to I/O expander implementation binaries.

JTAG

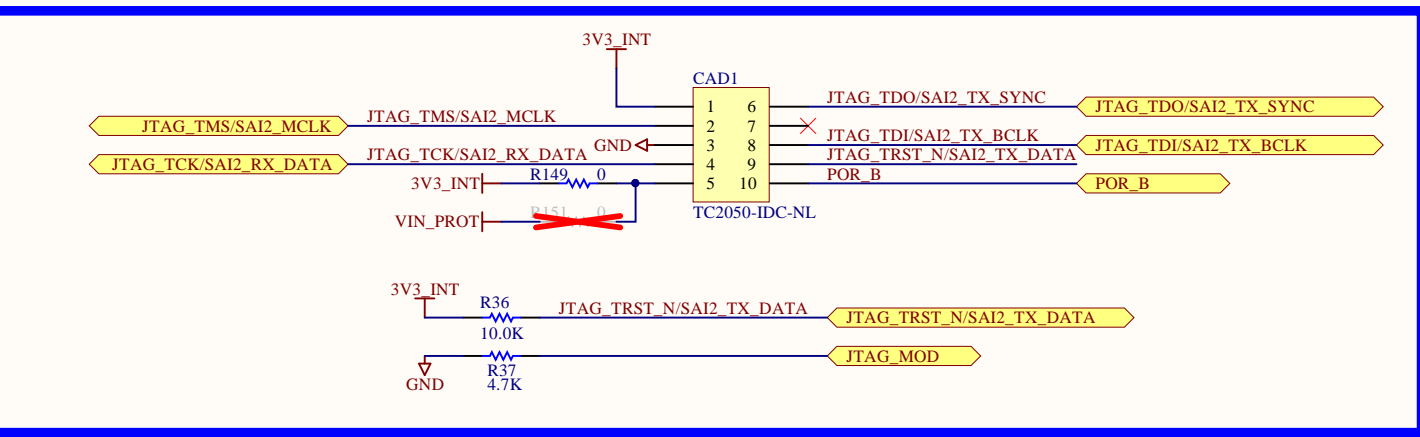

UART 1&3

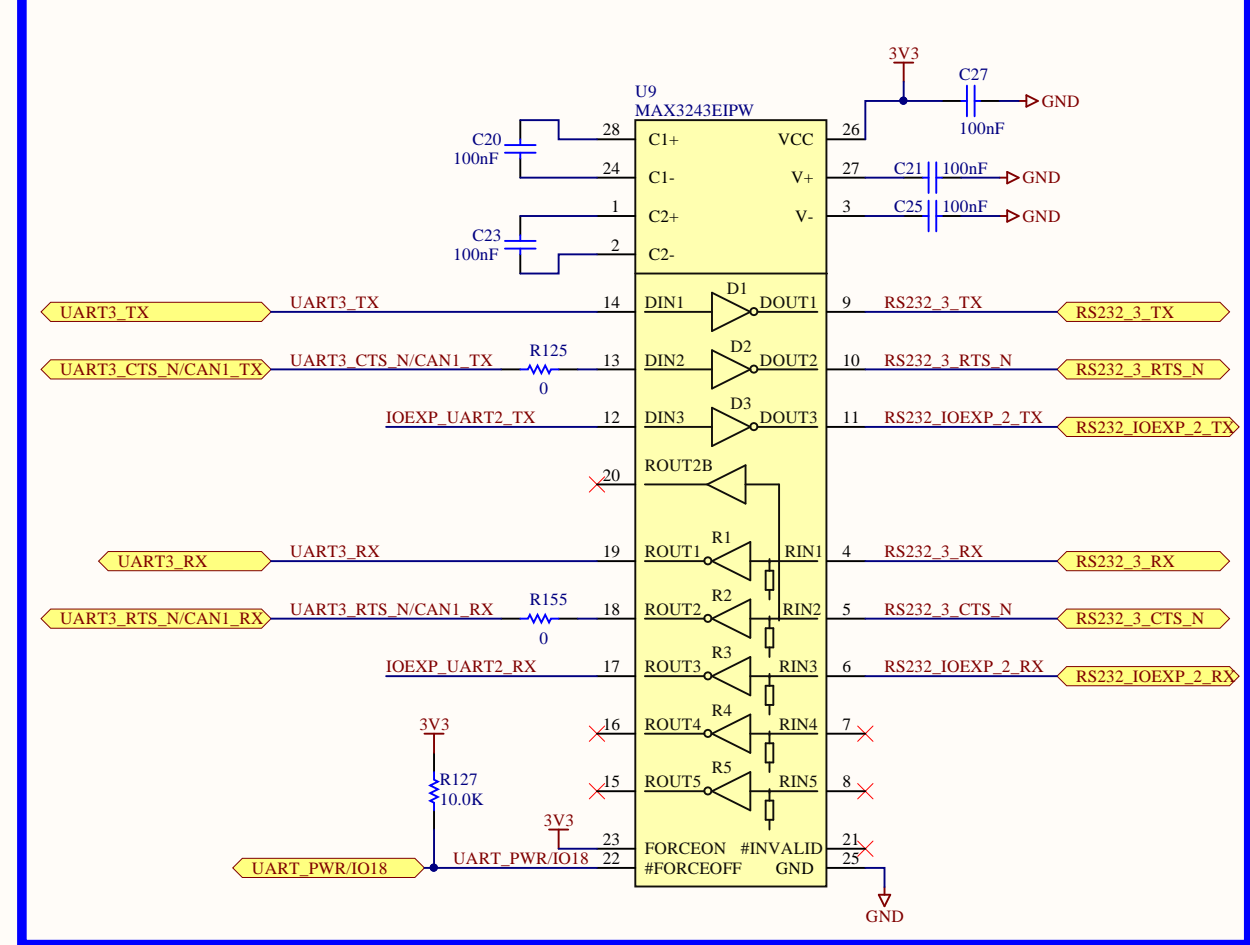

Console TTL

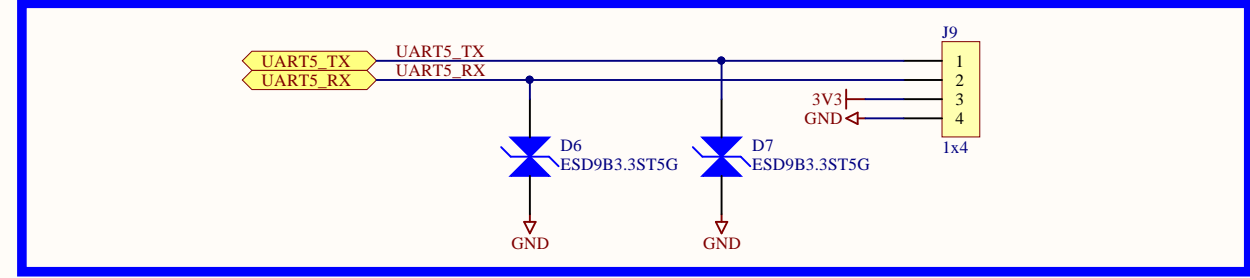

SWD

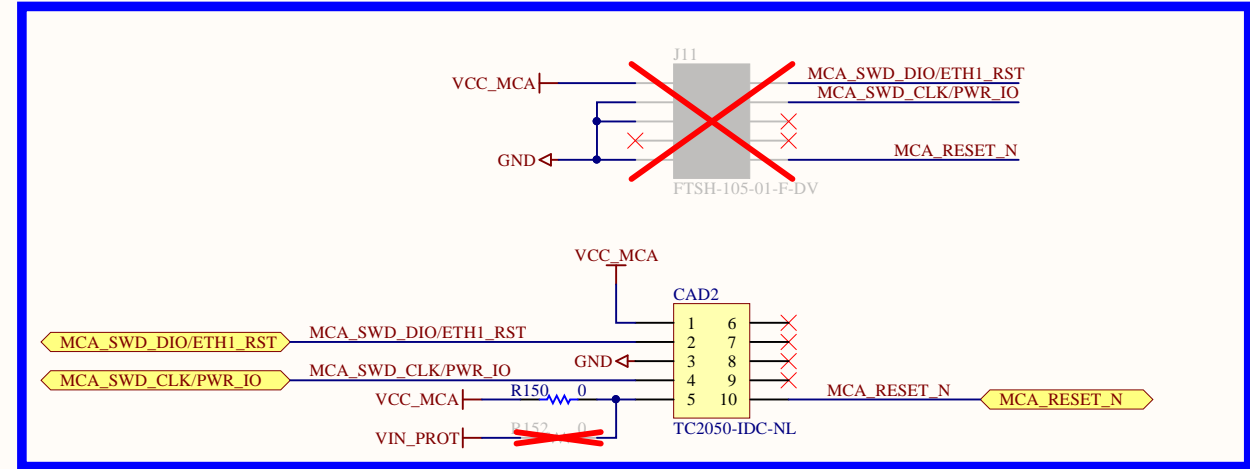

10/100M Ethernet

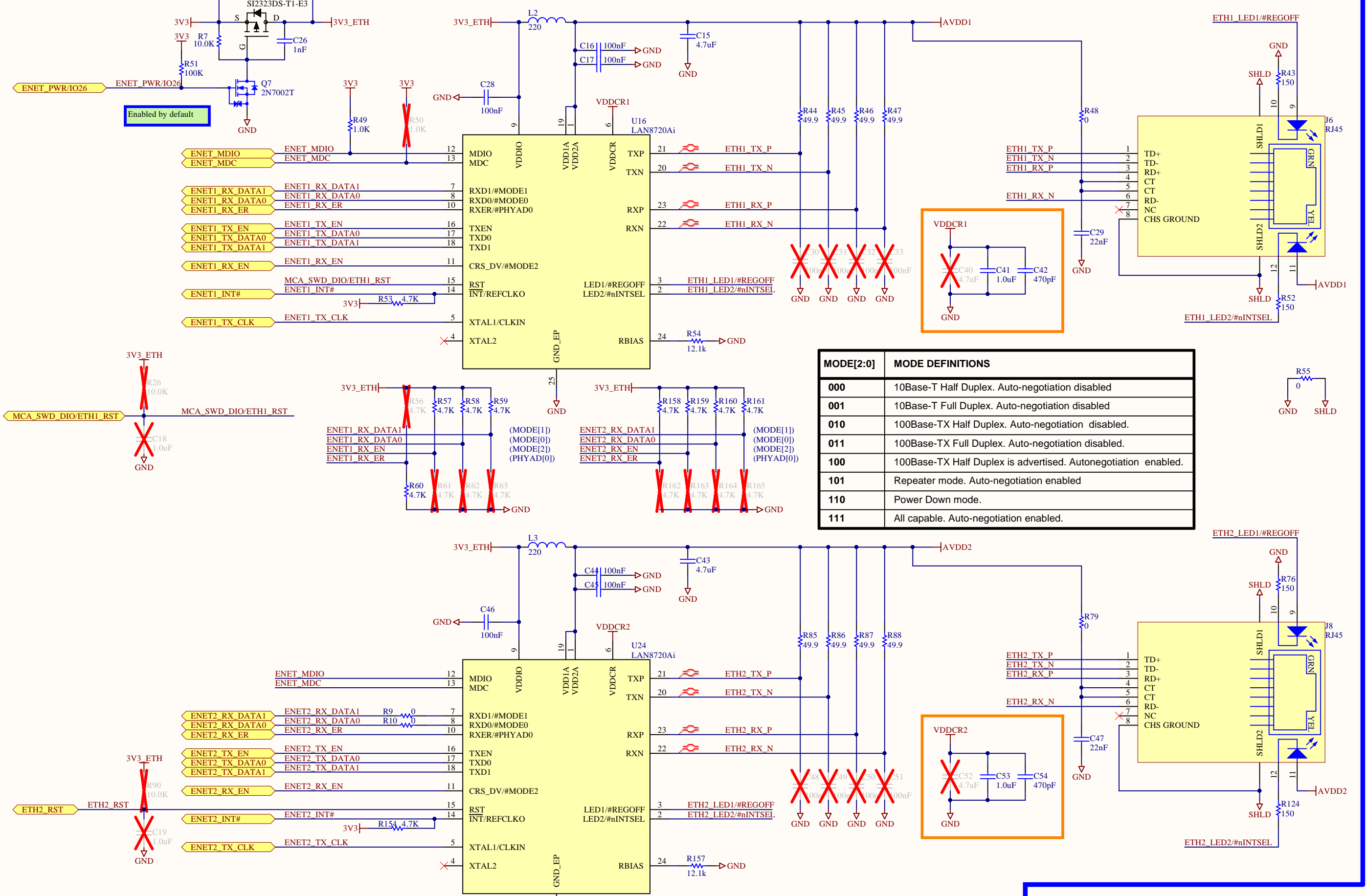

MODE[2:0]	MODE DEFINITIONS
000	10Base-T Half Duplex. Auto-negotiation disabled
001	10Base-T Full Duplex. Auto-negotiation disabled
010	100Base-TX Half Duplex. Auto-negotiation disabled.
011	100Base-TX Full Duplex. Auto-negotiation disabled.
100	100Base-TX Half Duplex is advertised. Autonegotiation enabled.
101	Repeater mode. Auto-negotiation enabled
110	Power Down mode.
111	All capable. Auto-negotiation enabled.

USB_HOST

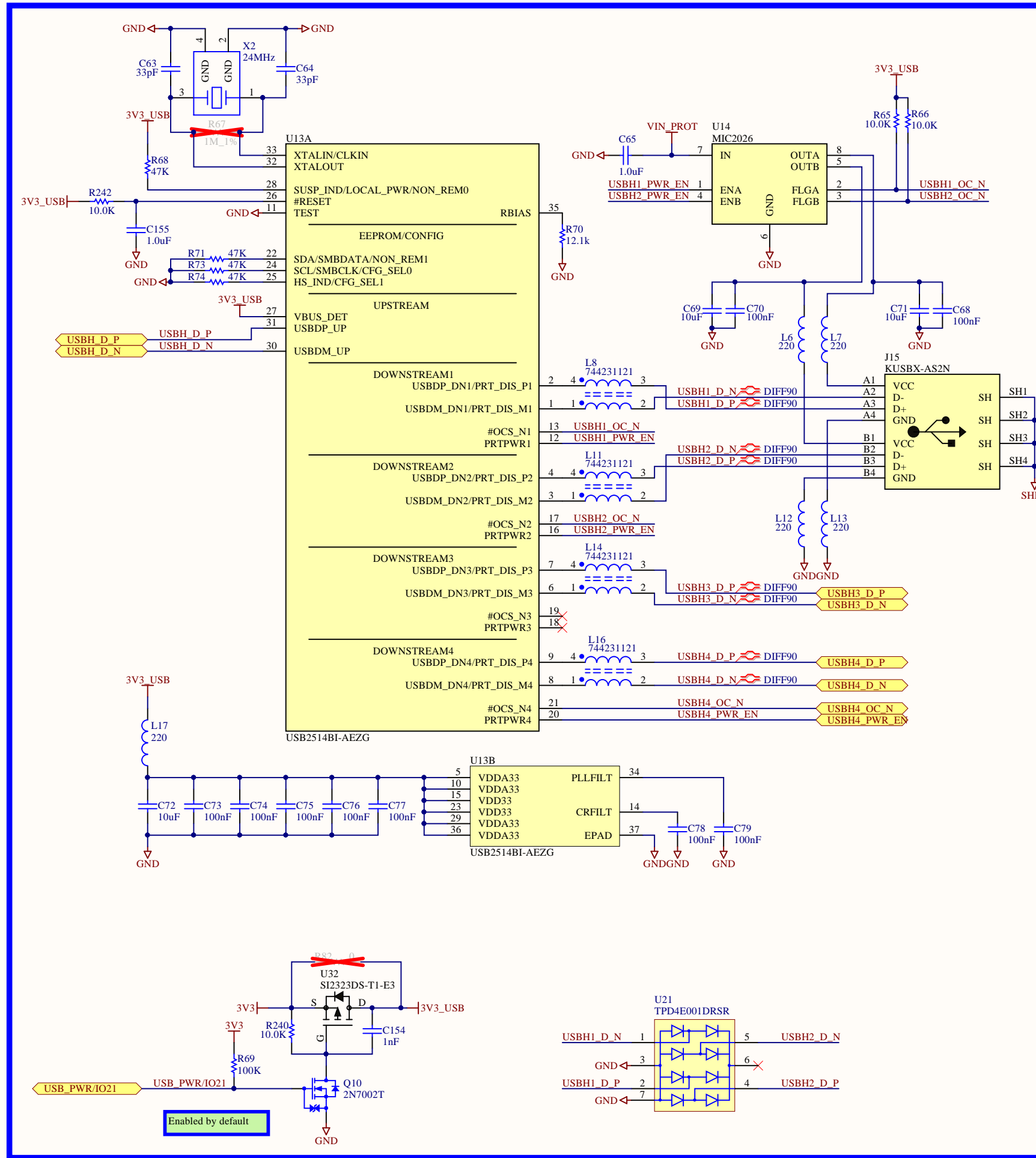

USB_OTG

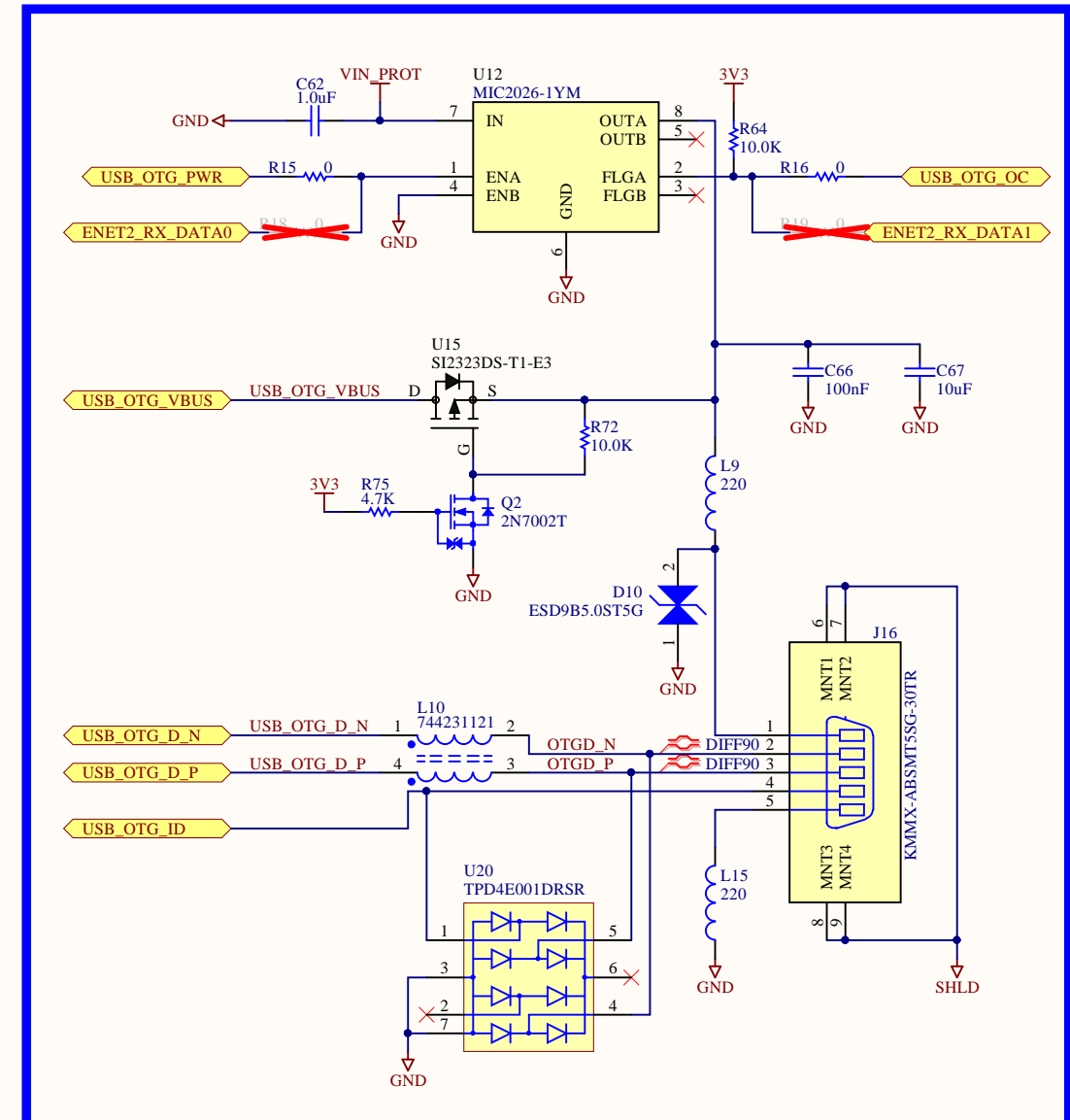

LVDS

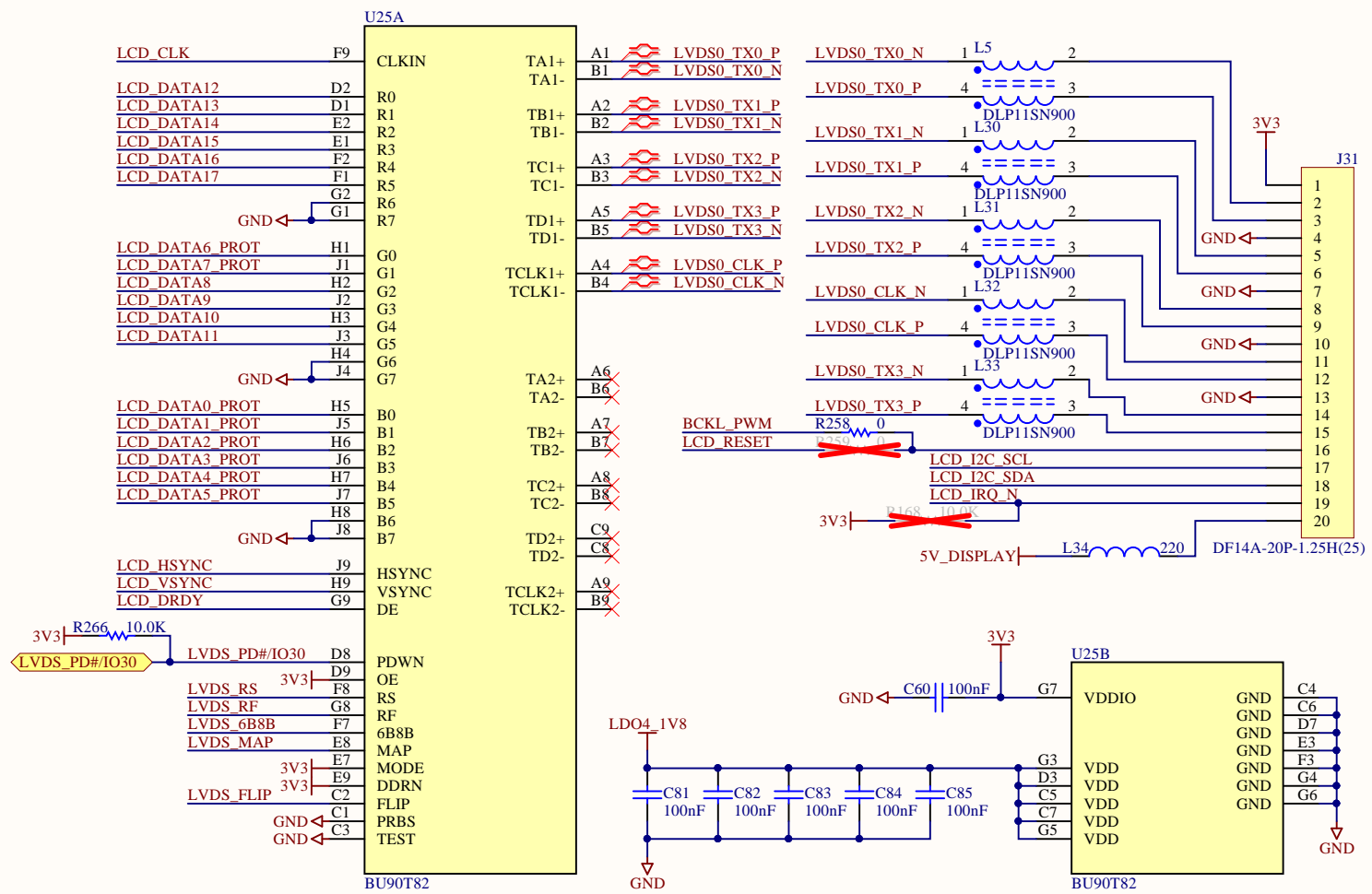

Parallel Display 0

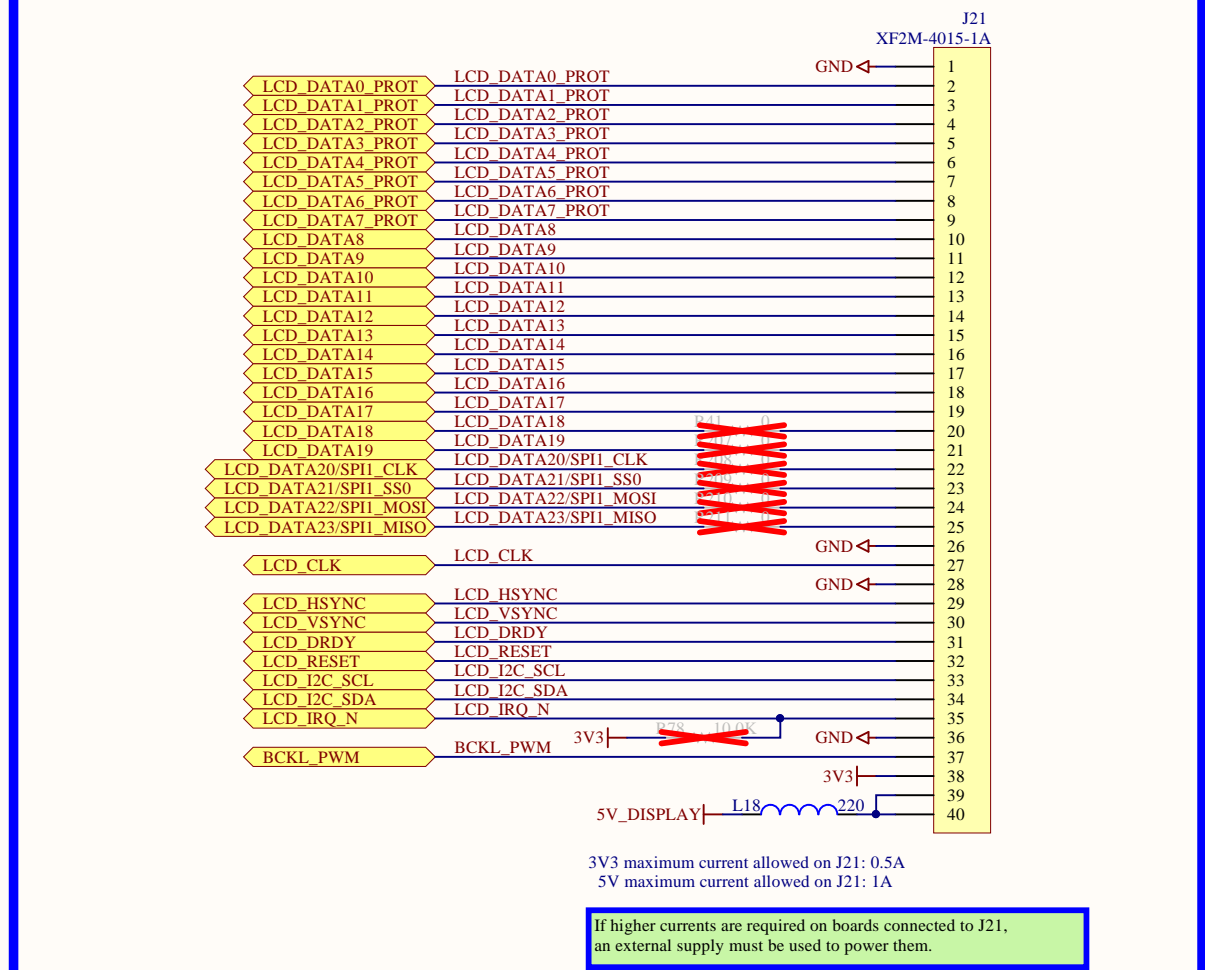

3V3 maximum current allowed on J21: 0.5A
 5V maximum current allowed on J21: 1A

If higher currents are required on boards connected to J21, an external supply must be used to power them.

Parallel Camera

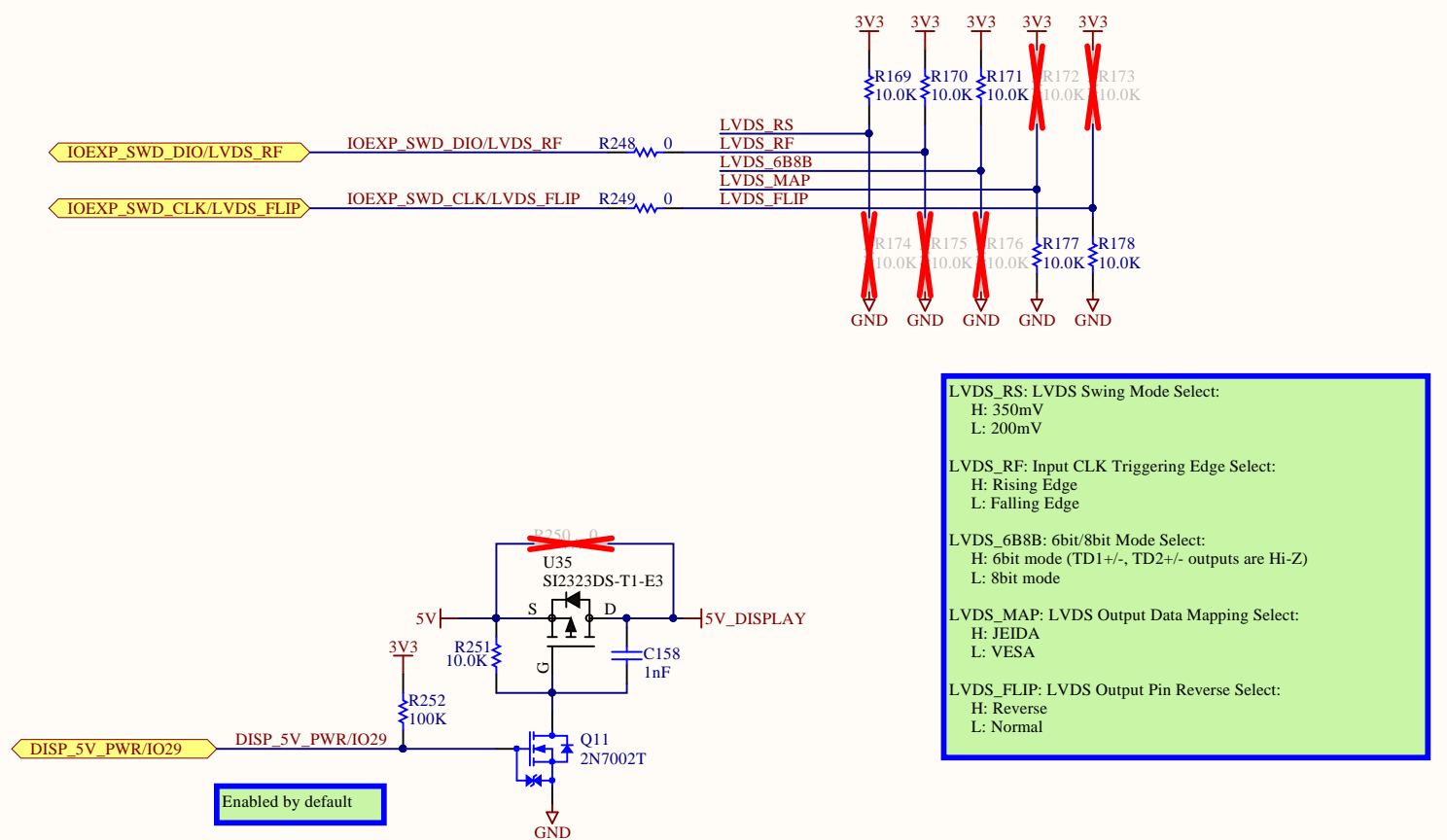

LVDS_RS: LVDS Swing Mode Select:
 H: 350mV
 L: 200mV

LVDS_RF: Input CLK Triggering Edge Select:
 H: Rising Edge
 L: Falling Edge

LVDS_6B8B: 6bit/8bit Mode Select:
 H: 6bit mode (TD1+/-, TD2+/- outputs are Hi-Z)
 L: 8bit mode

LVDS_MAP: LVDS Output Data Mapping Select:
 H: JEIDA
 L: VESA

LVDS_FLIP: LVDS Output Pin Reverse Select:
 H: Reverse
 L: Normal

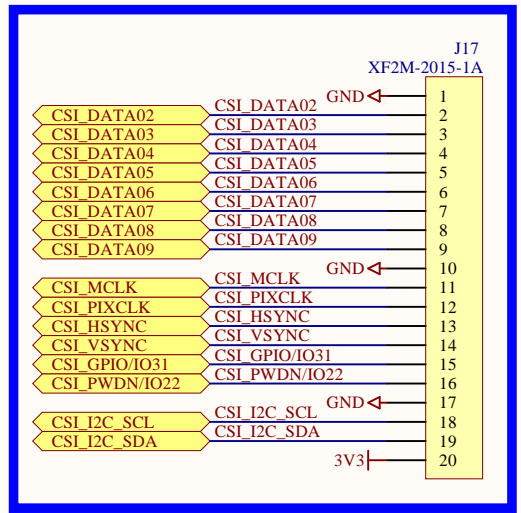

AUDIO

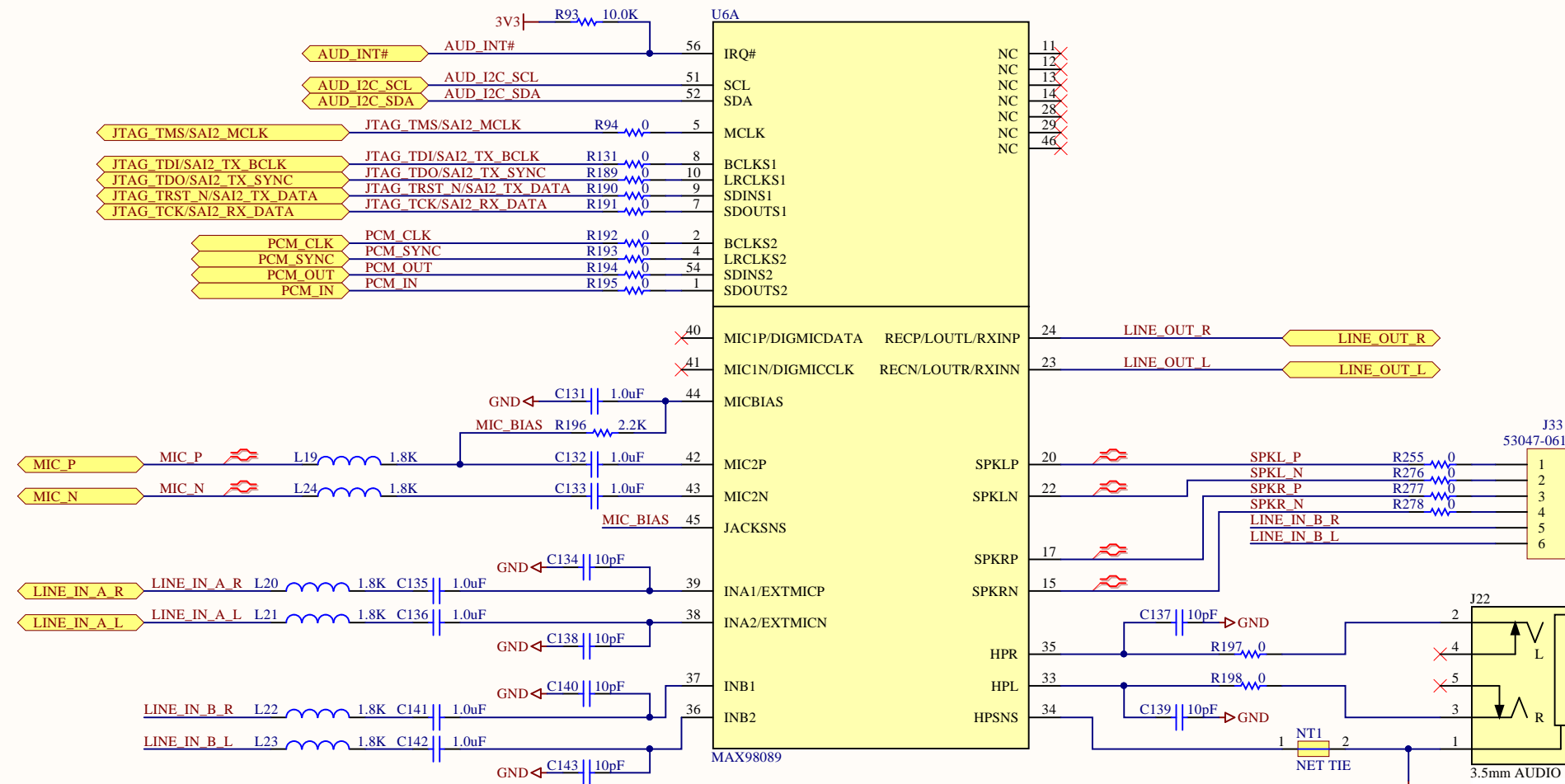

WARNING:
Right and left channels are inverted on J22.
J22.2 should be the left channel and J22.3 should be right channel.

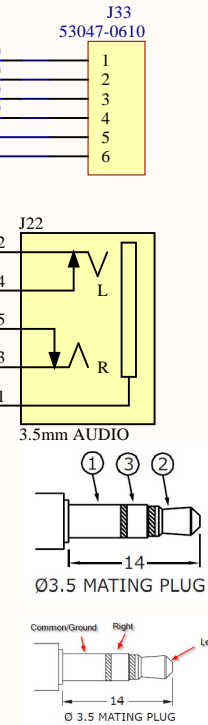

Model No.	SJ1-3515-SMT
Schematic	
PIN	
1	sleeve
2	tip
3	ring
10	tip switch
11	ring switch

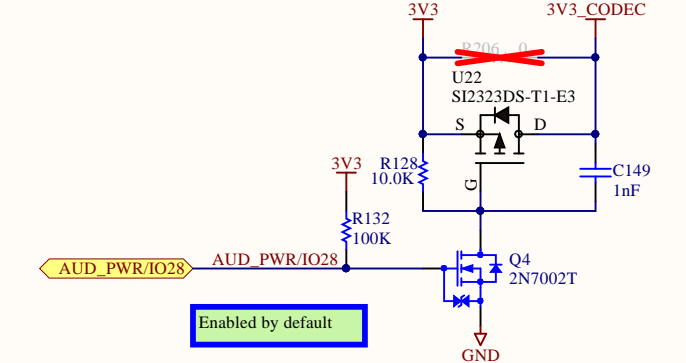
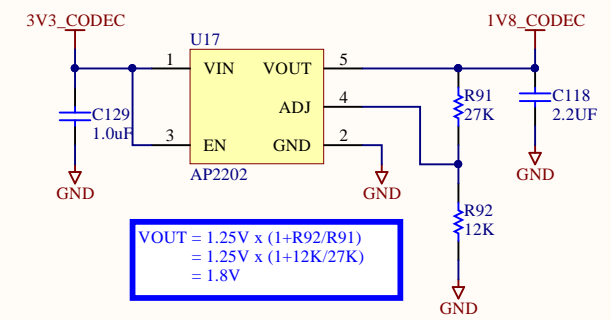
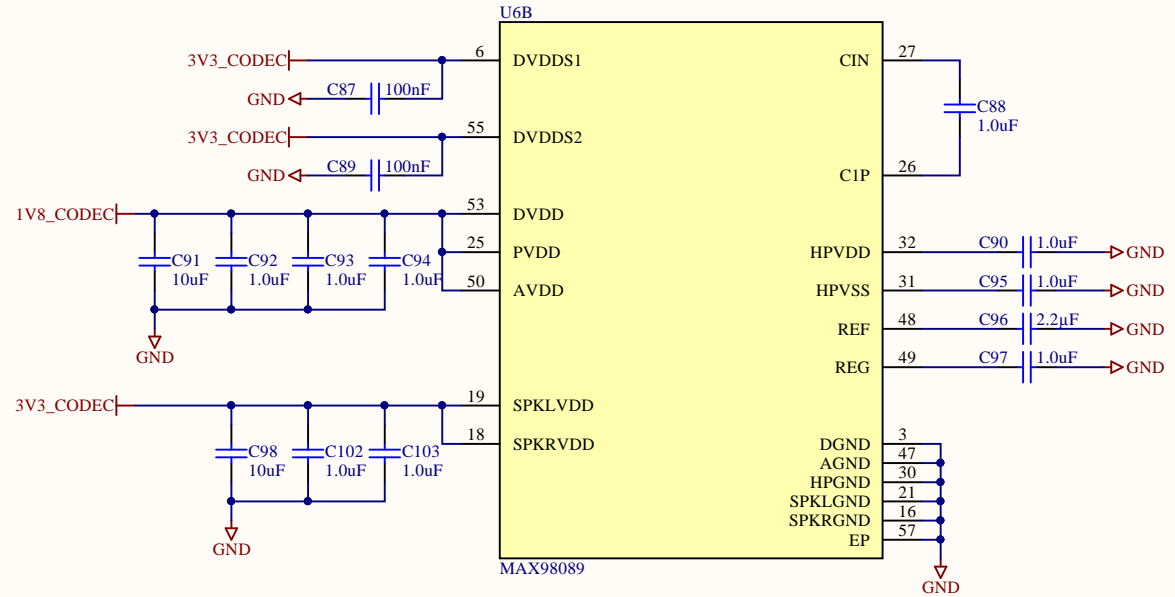

CAN1

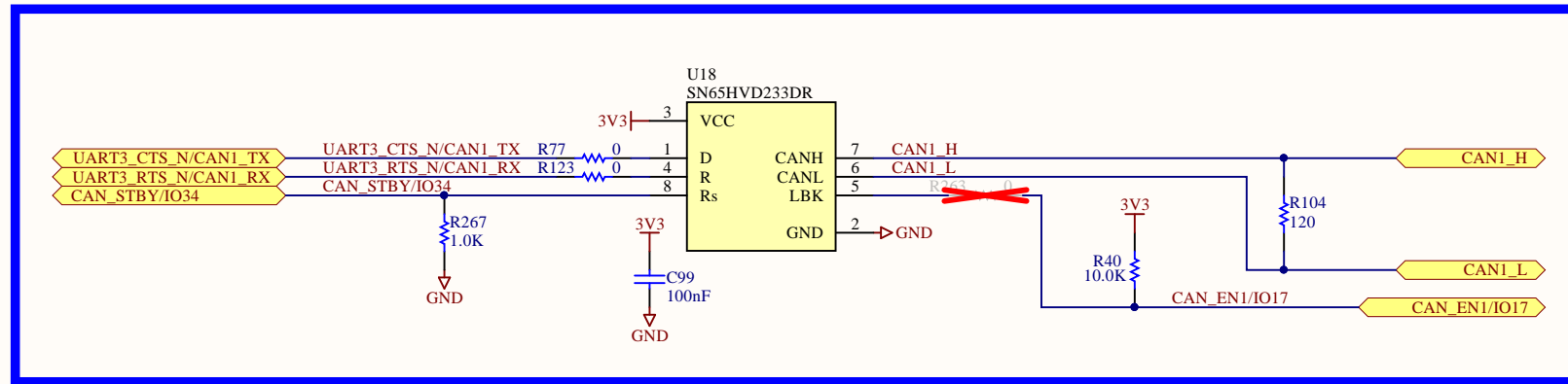

CAN2

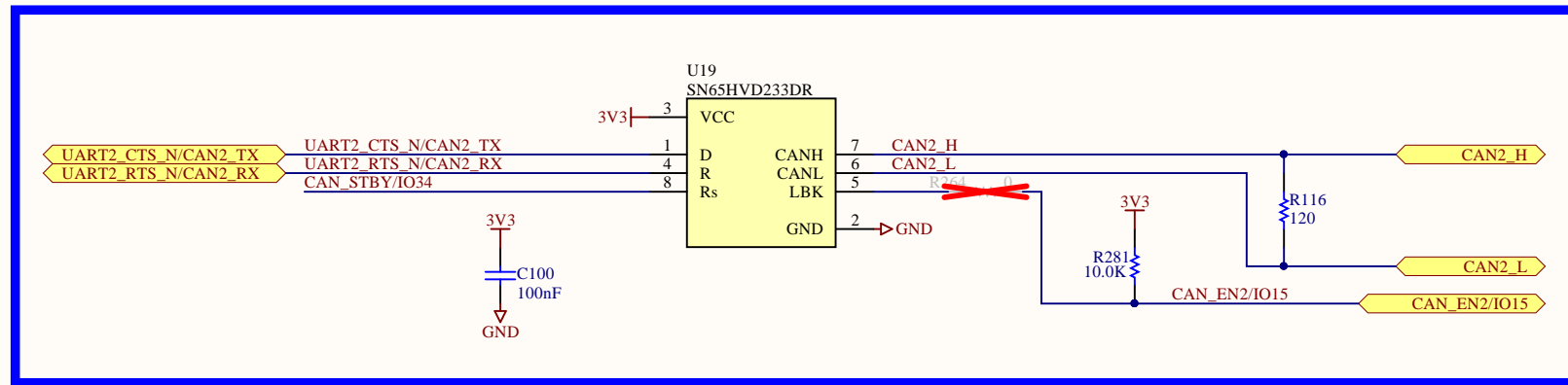

XBee

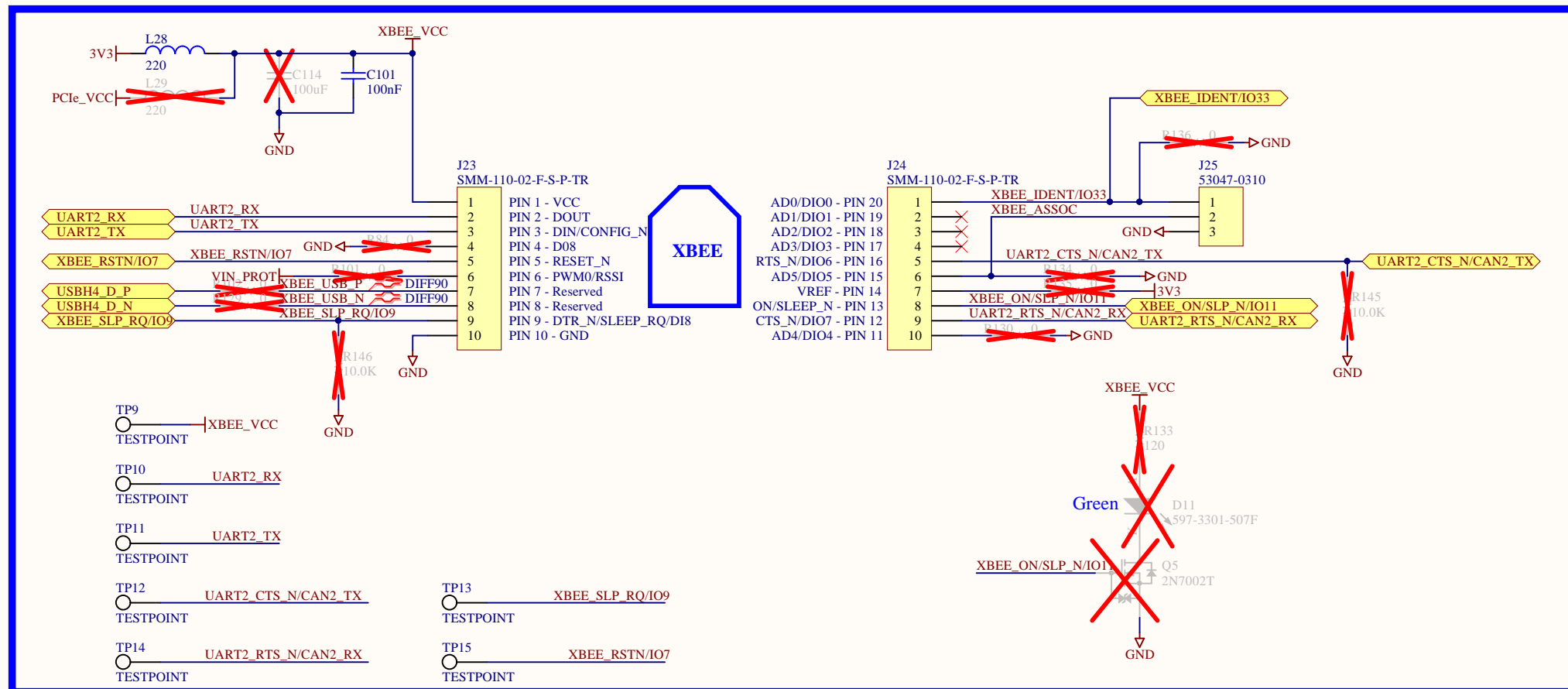

I2C

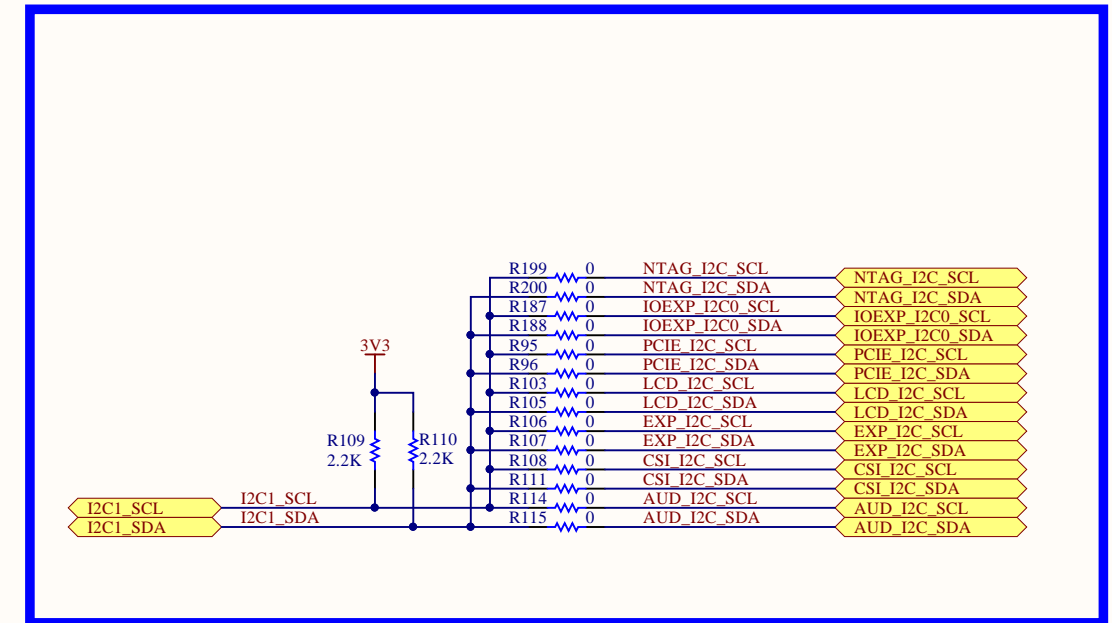

I2C1 (3.3V)

Peripheral	Speed (kbps)	Addresses (hex)	Default Address (hex)
PCIe Port	TBD	TBD	TBD
LVDS0 Touch	TBD	TBD	TBD
LCD Touch	TBD	TBD	TBD
Expansion Port	TBD	TBD	TBD
Camera	TBD	TBD	TBD
Audio CODEC	400	Write : 0x20 Read : 0x21	Write : 0x20 Read : 0x21
IOEXP	TBD	TBD	TBD
NTAG	TBD	Write : 0xAA Read : 0xAB	Write : 0xAA Read : 0xAB

CAN

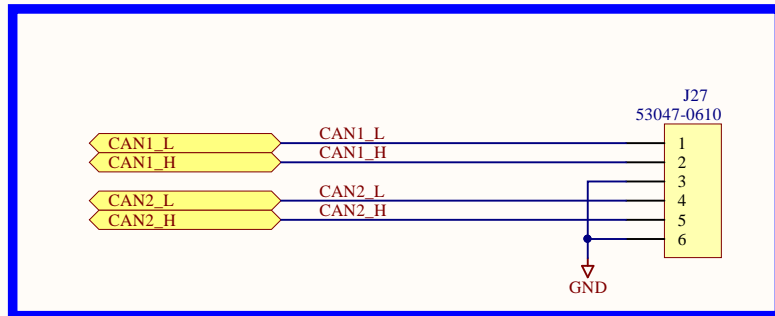

I2C

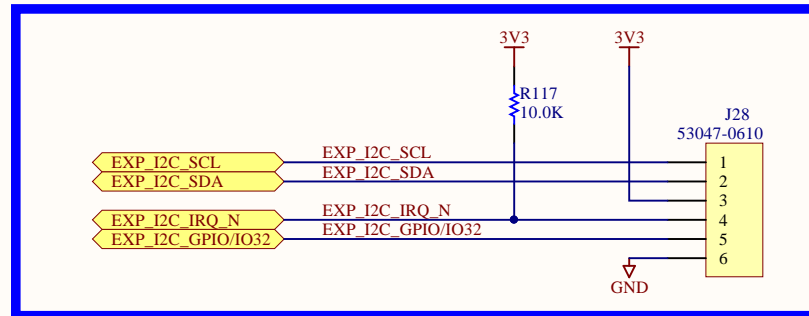

AUDIO

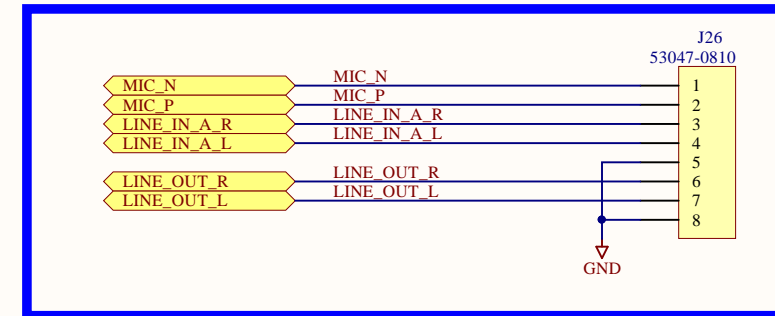

UART

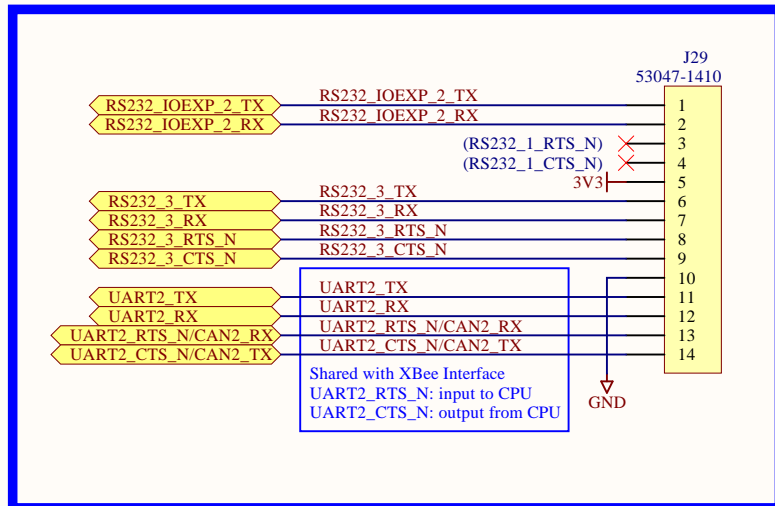

GPIO

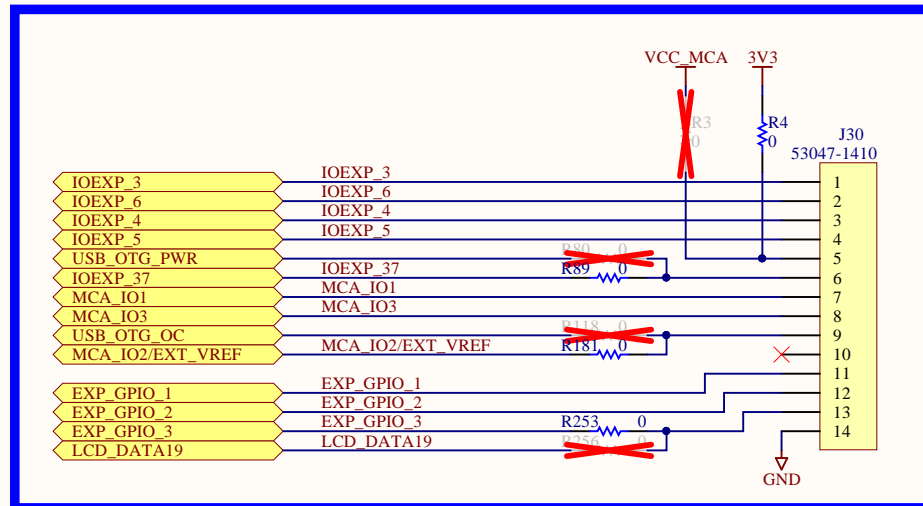

USER LED

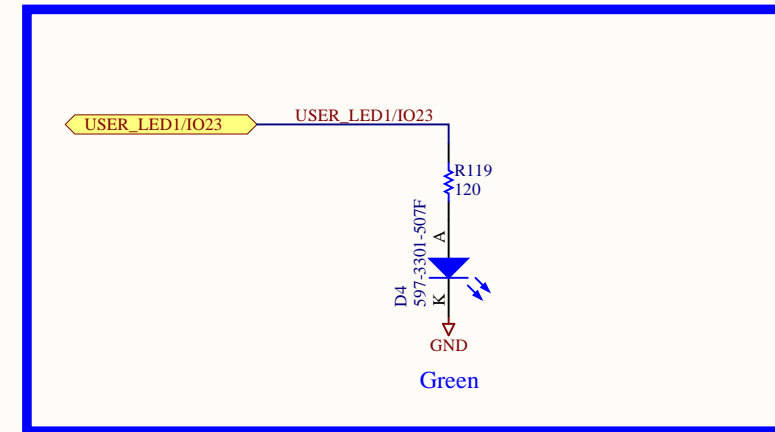

NFC NTAG I2C

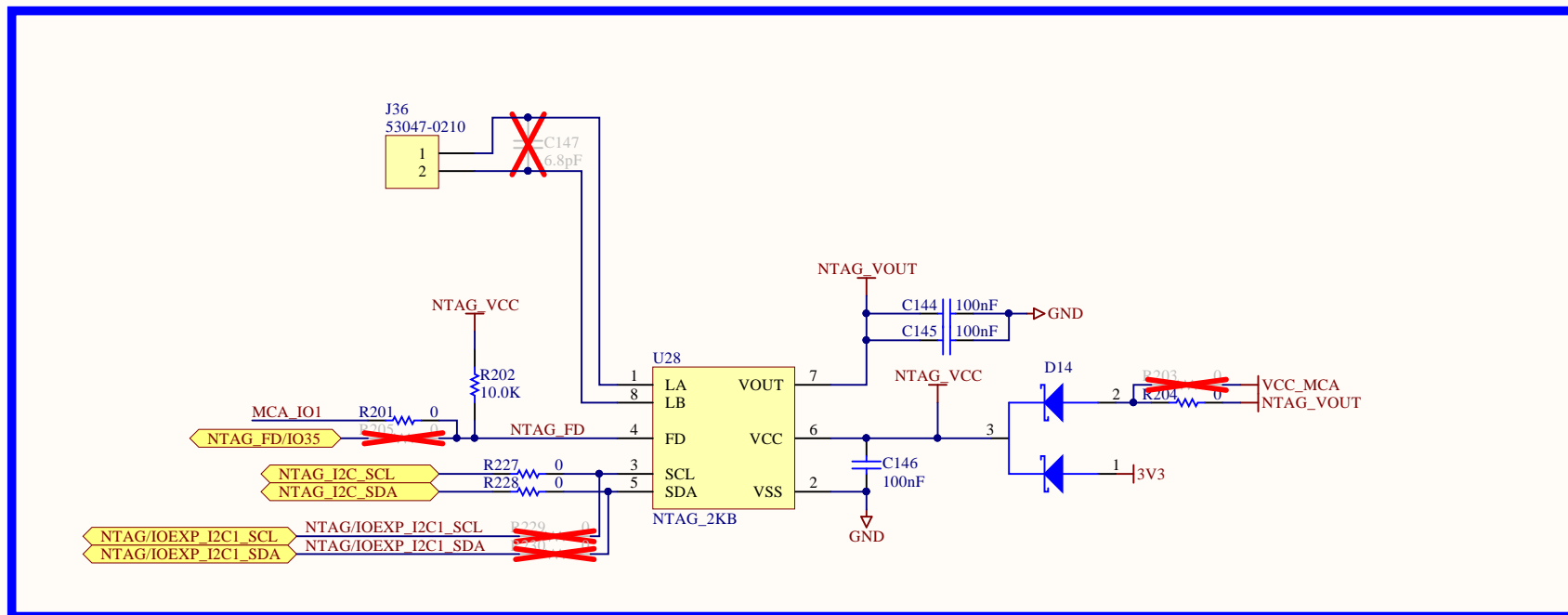

SPI

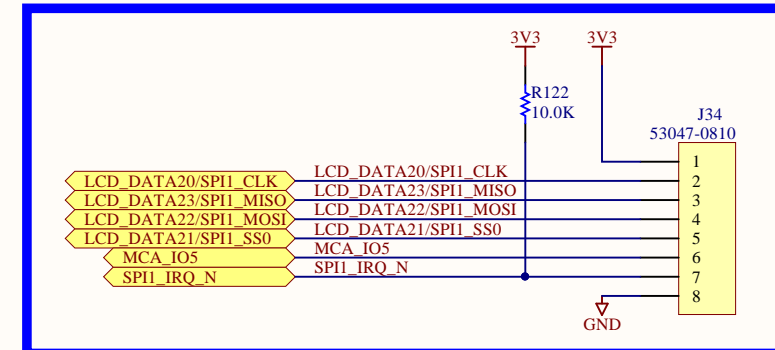

USB

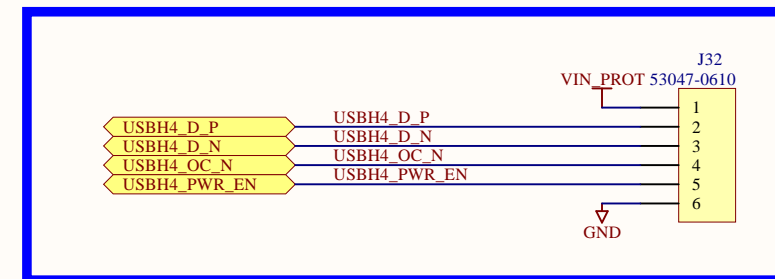

Bootstrap

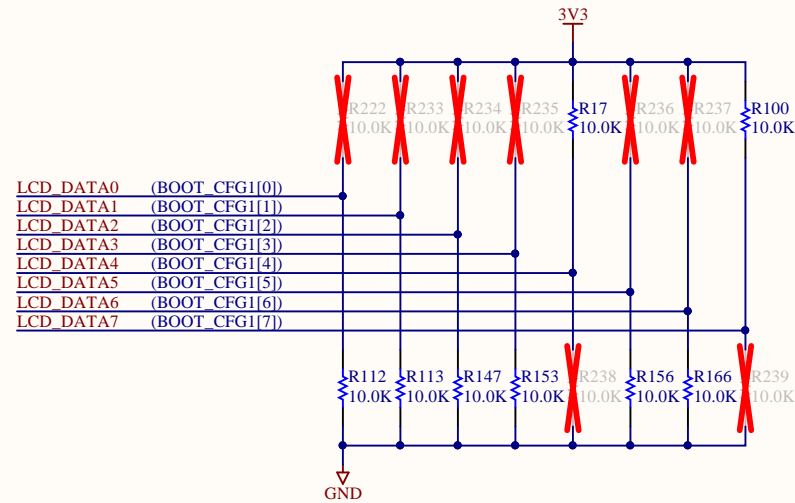

BOOTSTRAP	NAND
BOOT_CFG1[0]	Row Address Cycles: 00 - 3 cycles 01 - 2 cycles 10 - 4 cycles 11 - 5 cycles
BOOT_CFG1[1]	
BOOT_CFG1[2]	Number of devices: 00 - 1 device 01 - 2 devices 10 - 4 devices 11 - Reserved
BOOT_CFG1[3]	
BOOT_CFG1[4]	Pages in Block: 00 - 128 pages 01 - 64 pages 10 - 32 pages 11 - 256 pages
BOOT_CFG1[5]	
BOOT_CFG1[6]	Samsung's toggle mode DDR NAND 0 - Raw NAND 1 - Toggle mode NAND
BOOT_CFG1[7]	Boot Device Selection: 1 - Boot from NAND interface

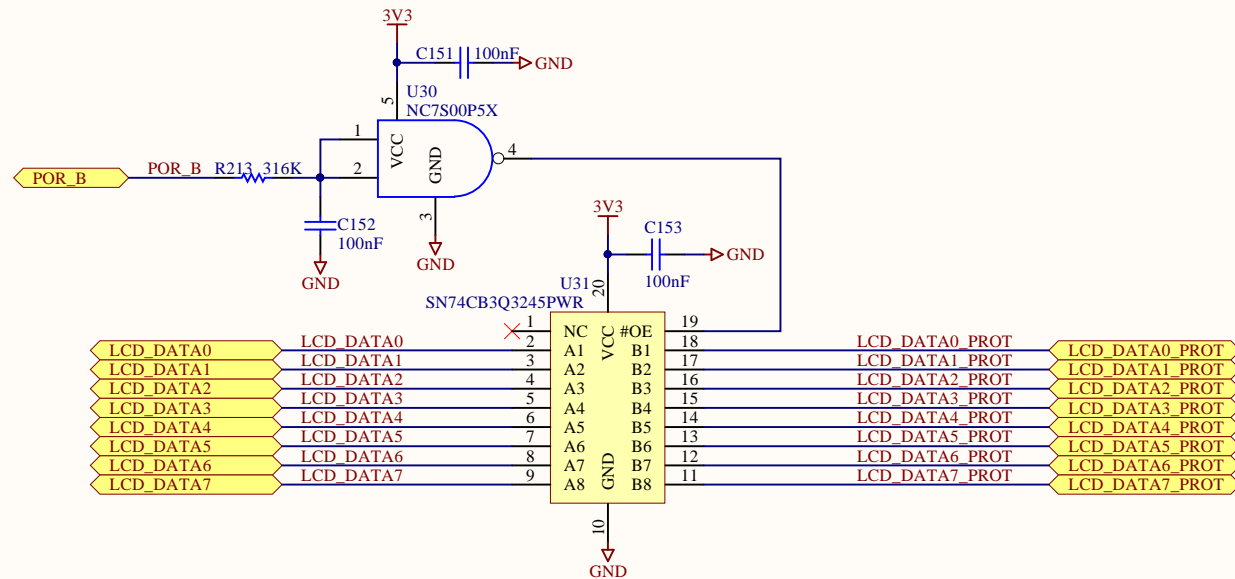

Boot Mode

BOOT_MODE1	BOOT_MODE0	Description
0	0	Boot from Fuses
0	1	Serial Downloader
1	0	Boot from board settings
1	1	Reserved

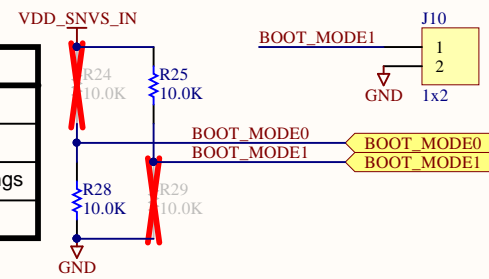

System Power Rails

Voltage (V)	Supply Name	Block	Generated by	Current Capability (mA)	Notes
5.0	VIN	Overvoltage Prot	External DC supply	-	
		MCA LDO			
	VIN_PROT	ConnectCore 6UL	Overvoltage Prot	-	
		5V load switch			
		USB Host VBUS			
		USB OTG VBUS			
	5V	LVDS0	Load switch (U7)	-	
		Parallel LCD			
		CC6UL VBUS			
3.3	3V3	eMMC	PMIC SW2	1250	
		microSD			
		UART RS-232			
		I/O EXPANDER			
		2x10/100M ENET			
		USB Hub			
		LVDS			
		Parallel LCD			
		Parallel Camera			
		AUDIO			
		CAN1/2			
		XBee			
	NTAG				
	PCIe_VCC	PCIe minicard	VIN_PROT	3000	
VCC_MCA	MCA	AP2202	150		
3.0	VCC_LICELL	RTC	External Coin Cell	-	
	VDD_SNVS_IN	BOOT	PMIC VSNVS	-	
1.8	LDO4_1V8	LVDS	PMIC LDO4	350	
	1V8_CODEC	AUDIO	AP2202	150	

GPIO Table

Signal Name	GPIO	Use
i.MX6UL processor		
GPIO1_5	GPIO1_5	EXP_GPIO_1
GPIO1_8	GPIO1_8	ENET1_INT#
GPIO1_9	GPIO1_9	ENET2_INT#
GPIO5_01	GPIO5_01	eMMC/SD#
GPIO5_02	GPIO5_02	LCD_IRQ_N
GPIO5_03	GPIO5_03	IOEXP_INT_IMX#
GPIO5_05	GPIO5_05	EXP_I2C_IRQ_N
GPIO5_06	GPIO5_06	ETH2_RST
GPIO5_07	GPIO5_07	AUD_INT#
GPIO5_08	GPIO5_08	SPI1_IRQ_N
MCA (KL03)		
SWD_CLK	PTA0	PWR_IO
MCA_IO0	PTB0/LLWU_P4	KL4_INT_MCA#
MCA_IO4	PTA9	BT_WAKEUP_HOST

Format: DD/MM/YYYY

12/02/2016 - ConnectCore i.MX6UL Single Board Computer
* Initial version

19/09/2016 - ConnectCore i.MX6UL Single Board Computer
* NPR004795 : 55001883-01 rev 03:
- PCB spin: 3001517x-01 revA => 3001517x-02 revA

08/11/2016 - ConnectCore i.MX6UL Single Board Computer
* NPR004832 : 55001883-01 rev 1P:
- Change R212 to 2.2M
- Populate R140
- Change R257 to 37K
- Depopulate BT and WLAN LEDs
- Marked CC6UL pad B7 as Reserved. This signal is used on the module.

21/02/2017 - ConnectCore i.MX6UL Single Board Computer
* ECO007182 : 55001883-01 rev 2P:
- Renamed signal CSIO_RSTN/IO22 in CSIO_PWDN/IO22
- Depopulate R121 (JIRA: CC6UL-541)
- Renamed signal MCA_IO2 in MCA_IO2/EXT_VREF
- Replace U11 P/N from 50001916-01 to 50001939-01
- Replace R24,R25, R28 and R29 resistors values from 1K to 10K (JIRA CC6UL-624)

05/05/2017 - ConnectCore 6UL SBC PRO
* ECO007036 : 55001883-01 rev A:
- Renamed nets CSIO_x into CSI_x
- Renamed signal DISP0_x into LCD_x
- Depopulate U10, C150, R260 and R231
- Renamed signal IOEXP_IO37 into IOEXP_37
- Depopulate R78 and R168 (fixing JIRA DEL-4191)

LBL1
LABEL
28000351_LABEL

TXT1
LABEL
TEXT
95017001

