

# *ConnectCore™ XP 270*

## *Hardware Reference*

---

**Part number/version: 9000759\_C**  
**Release date: August 2007**  
**[www.digi.com](http://www.digi.com)**

©2005-2006 Digi International Inc.  
Printed in the United States of America. All rights reserved.

Digi, Digi International, the Digi logo, the Making Device Networking Easy logo, NetSilicon, a Digi International Company, NET+, NET+OS and NET+Works are trademarks or registered trademarks of Digi International, Inc. in the United States and other countries worldwide. All other trademarks are the property of their respective owners.

Information in this document is subject to change without notice and does not represent a commitment on the part of Digi International.

Digi provides this document “as is,” without warranty of any kind, either expressed or implied, including, but not limited to, the implied warranties of, fitness or merchantability for a particular purpose. Digi may make improvements and/or changes in this manual or in the product(s) and/or the program(s) described in this manual at any time.

This product could include technical inaccuracies or typographical errors. Changes are made periodically to the information herein; these changes may be incorporated in new editions of the publication.

**Digi International**  
**11001 Bren Road East**  
**Minnetonka, MN 55343 U.S.A.**  
**United States: +1 877 912-3444**  
**Other locations: +1 952 912-3444**

**[www.digi.com/support/](http://www.digi.com/support/)**  
**[www.digi.com](http://www.digi.com)**

# Contents

---

Documentation updates .....	viii
<b>Chapter 1: About the Module</b> .....	<b>1</b>
Intel XScale PXA270 .....	2
ConnectCore XP 270 module .....	3
Using the ConnectCore XP 270 chip select.....	5
Reset Logic.....	6
Watchdog .....	6
Clock signals .....	7
Flash memory .....	7
SDRAM memory.....	7
Power Management Chip for PXA270 processor .....	8
Ethernet Controller.....	9
External schematics for SMSC LAN91C111 Ethernet Controller.....	10
1-Wire EEPROM.....	12
USB.....	14
UARTs.....	20
SSP Serial Ports.....	21
I <sup>2</sup> C Bus Interface .....	22
PC Card and CompactFlash Interface.....	22
MultiMedia Card / SD / SDIO Controller + Memory Stick.....	23
LCD Controller.....	24
AC'97 Controller .....	27
Pulse Width Modulator Controller .....	27
Connector pinout .....	28
ConnectCore XP pinouts: Connector X1 .....	28

ConnectCore XP pinouts: Connector X2 .....	33
ConnectCore XP 270 GPIOs .....	36
Bidirectional GPIOs .....	37
ConnectCore XP 270 GPIO use .....	37
GPIO Controller Register Summary.....	46
GPIOs used internally .....	47
ConnectCore XP 270 Memory Map.....	48
<b>Chapter 2: About the Development Board .....</b>	<b>51</b>
XScale .....	52
What's on the development board?.....	53
General Precautions.....	54
Installation.....	55
Replacing the module .....	55
Setting up basic and optional connections.....	57
Hardware block diagram .....	58
LEDs and selection of Ethernet magnetics.....	59
Jumpers .....	59
Pin descriptions .....	61
ConnectCore XP 270 X1 pinout .....	77
ConnectCore XP 270 X2 pinout .....	81
<b>Chapter 3: ConnectCore XP 270 Customization .....</b>	<b>87</b>
Adding custom hardware to the development board .....	88
Custom development board design check list.....	88
<b>Appendix A: ConnectCore XP 270 Module Specifications 91</b>	
Mechanical dimensions .....	92
Environmental information.....	93
Power requirements.....	94
Layout considerations.....	94
<b>Appendix A: JTAG-Booster for Intel XScale PXA270 97</b>	
Overview.....	98
System requirements.....	98

CD files .....	99
Connecting your PC to the target system .....	99
Initialization file JTAG270.INI .....	100
Supported Flash devices .....	100
JTAG270 Parameter Description .....	101
Program a Flash Device .....	103
Use: JTAG270 /P filename [optionlist] .....	103
Options .....	103
Example with Intel PXA270.....	106
Support for Windows NT, Windows 2000 and Windows XP .....	107
Installation on a clean system .....	108
Installation with an already installed version 5.x/6.x of Kithara .....	108



# Using This Guide

---

**R**eview this section for basic information about the guide you are using, as well as general support and contact information.

## About this guide

---

This guide provides information about the Digi ConnectCore XP 270, a fully integrated system-on-chip solution on a 67.6 x 36.7mm card.

The ConnectCore XP 270 module is built on the Intel XScale processor PXA270, flash and SDRAM memory, and the SMSC LAN91C111 Ethernet controller.

## What's in this guide

---

This table shows where you can find specific information in this guide.

To read about	See
ConnectCore XP 270 module	Chapter 1, “About the Module”
ConnectCore XP development board	Chapter 2, “About the Development Board”
Customizing the ConnectCore XP 270	Chapter 3, “ConnectCore XP 270 Customization”
Module specifications	Appendix A, “ConnectCore XP 270 Module Specifications”

To read about	See
Using the JTAG-Booster	Appendix B, “JTAG -Booster for Intel XScale PXA270”

## Conventions used in this guide

This table describes the typographic conventions used in this guide:

This convention	Is used for
<i>italic type</i>	Emphasis, new terms, variables, and document titles.
monospaced type	Filenames, pathnames, and code examples.

## Related documentation

- Intel® PXA27x Processor Family  
Developer’s Manual  
October 2004  
Order Number: 280000-002

## Documentation updates

Digi occasionally provides documentation updates on the Web site ([www.digi.com/support](http://www.digi.com/support)).

Be aware that if you see differences between the documentation you received in your package and the documentation on the Web site, the Web site content is the latest version.

## Customer support

---

To get help with a question or technical problem with this product, or to make comments and recommendations about our products or documentation, use the contact information listed in this table:

For	Contact information
Technical support	United States: +1 877 912-3444 Other locations: +1 952 912-3444 <a href="http://www.digi.com/support">www.digi.com/support</a> <a href="http://www.digi.com">www.digi.com</a>

---



---

# *About the Module*

---

## C H A P T E R 1

The ConnectCore XP 270 module is a fully integrated system-on-chip solution on a 67.6 x 36.7mm card – a system built on Intel XScale processor PXA270, flash and SDRAM memory, and the SMSC LAN91C111 Ethernet controller.

## Intel XScale PXA270

---

### *Features*

- Intel XScale Technology highly scalable core from 104 MHz up to 520 MHz
- Little Endian operation
- Embedded Packaging: 23 x 23 mm with 1.0 mm ball pitch
- Enhanced LCD Controller
- Large Peripheral Set:
  - USB Host / Client
  - USB OTG
  - PCMCIA / Compact Flash
  - IrDA
  - I<sup>2</sup>C
  - AC97 Controller
  - Full Function UART
  - Bluetooth UART
  - LCD controller
  - SSP and NSSP Serial ports

*Intel XScale PXA270 processor block diagram*

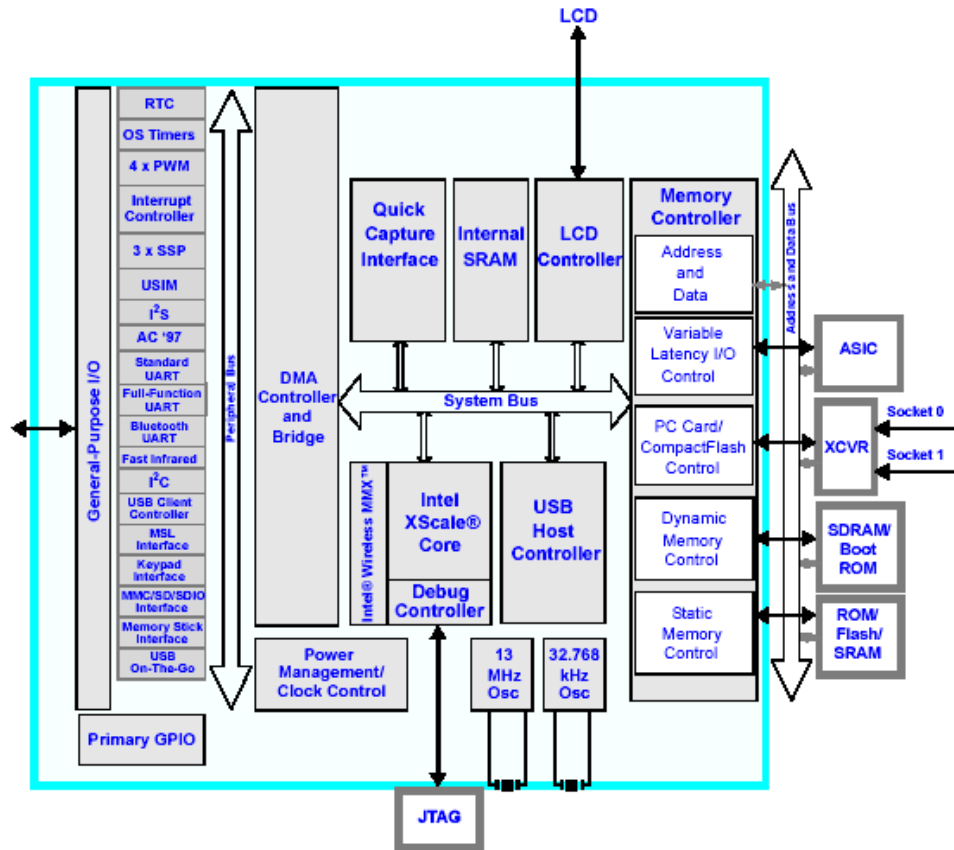

ConnectCore XP 270 module

**Features**

- 32-bit Intel XScale PXA270 processor
- 64 Mbytes SDRAM memory (32-bit@100 MHz)
- 32 Mbytes Flash memory (32-bit)

- 1 Full Function UART, 1 Bluetooth UART, 1 IrDA, 1 NSSP, 1 SSP serial port
- I<sup>2</sup>C Bus
- USB Host and/or USB Device
- GPIOs and Interrupt signals
- PCMCIA / Compact Flash interface
- Multimedia Card/SD/SDIO Controller
- LCD controller
- 10/100 Mbit/s Ethernet connection (through the SMSC chip LAN91C111)
- 1-wire EEPROM DS2431
- AC'97 interface
- PWM
- DMA request pins
- Complete external 32-bit interface available
- Reset circuitry
- Single +3.3V Power Supply
- Integrated Power I2C interface
- PMIC - Power Management IC supporting PXA270 DVM (Dynamic Voltage Management)
- JTAG interface



## Reset Logic

The Connect Core XP 270 module has two reset signals:

- RESET\_IN#
- RESET\_OUT#

Both signals are low-active. If RESET\_IN# is activated outside the module (through reset controller or reset button), the signal is first debounced by the on-board reset circuitry (MAXIM MAX6390XS29D4 chip) and a reset signal is transmitted to the PXA270 processor. The reset input of the PXA270 can also be activated by a power-on sequence.

Once the processor receives the reset input signal, it resets its internal peripherals and a processor specific output reset signal – RESET\_OUT# – becomes active. This signal is available on ConnectCore XP 270 connectors.

On-board flash memories receive the reset signal through the RESET\_IN# pin and the Ethernet controller receives the reset signal through the RESET\_OUT# signal.

Intel PXA270 power-on sequence timing is fully respected on the ConnectCore XP 270 module – no special care has to be taken outside the module. For more information about power on timing, see “Intel PXA270 Processor Electrical, Mechanical and Thermal Specification - Order Number 280002-004 p.64.”

## Watchdog

The Intel XScale PXA270 processor comes with a watchdog unit. The processor’s OSCRO register can be programmed to generate a watchdog-reset signal. When the OOWER[WME] field is set, the OSCRO register is compared to the OSMR3 register every rising edge of the internal-made 3.25MHz clock.

If a match is detected, the OS timer asserts the internal WDOG\_RST pin, which asserts the RESET\_OUT# pin. A reset is applied to the PXA270 processor and most internal states are cleared.

Once enabled, the watchdog function can be disabled only by one of the reset functions (hardware reset, watchdog reset, or GPIO reset). Writing a zero to the Watchdog Match Enable bit after it has been set has no effect.

For more information about the watchdog unit, see the “Intel PXA27x Processor Family Developer’s Manual - Order Number: 280000-002”.

## Clock signals

The processor needs two clock signals:

- The 13-MHz processor oscillator provides the primary clock source for the PXA270 processor. The on-chip PLL frequency multipliers and several peripheral modules use the processor oscillator as a reference. If the application has not enabled the 32.768-kHz timekeeping oscillator, the processor oscillator also drives the real-time clock (RTC) and power manager.
- The 32.768-kHz timekeeping oscillator is a low-power, low-frequency oscillator that clocks the real-time clock (RTC) and power manager.

Both clock sources are used and implemented on the ConnectCore XP 270 module.

## Flash memory

The ConnectCore XP 270 module support two Intel StrataFlash Flash Memory chips. Each chip is 16-bit wide, making a whole 32-bit Flash Memory area. All accesses to the flash memory are made with 32-bit words.

The Flash Memory chips are controlled by CS0#, so the module can support a maximum of 64MB of memory. Flash Memory chips have an initial access speed of 120ns and a block sector size of 64-Kword (= 128-Kbyte).

The Flash Memories reset signal is connected to the RESET\_IN# input signal. With this choice, Flash Memories aren't reset for software reset events such as sleep mode, watchdog reset, and GPIO reset.

## SDRAM memory

Intel PXA270 processor supports a SDRAM interface at a maximum frequency of 104 MHz. On the ConnectCore XP 270 module, two SDRAM memory chips have been connected to the processor SDRAM partition 0 (controlled by SDCS0# signal).

There are two possible considerations regarding the size of SDRAM partition on a PXA270-based product:

- Use a normal 256-Mbyte memory map; in this case, the SDRAM partition is 64-Mbyte wide.

- Use a large 1-Gbyte memory map; in this case, the SDRAM partition is 256-Mbyte wide. This memory map allows the possibility of connecting to bigger SDRAM chips.

**Note:** As far as SDRAM signals available on ConnectCore XP 270 module connectors, the signals are available as references only. The module has not been adapted to support SDRAM memory outside the module, nor “length-adapted” to support PXA270 SDRAM timing.

### Power Management Chip for PXA270 processor

The ConnectCore XP 270 module comes with an integrated chip that manages Intel XScale PXA270 voltages and can implement some minor power management functions. The chip is a versatile power management IC designed especially for the XScale type of processors. The chip contains three regulators, which share a common enable pin. When disabled using the enable pin, the chip enters a low-power state.

To assure stability and minimize overshoot at start-up and during DVM transitions, Power Management IC implements a controlled rise time of each regulator output.

This is a short list of available features implemented by the PMIC (Power Management Integrated Circuit):

- Three voltage regulators (1 Buck for core voltage, 2 LDOs for SRAM, and PLL voltage)
- Full-integrated synchronous buck regulator with DVM (Dynamic Voltage Management) – 800mA DC output current
- I<sup>2</sup>C interface module for DVM from 0.58V to 1.6V
- Battery fault signal
- Input supply voltage range: 2.76V - 5.5V
- 4x4 mm QFN package

**Note:** The power management chip doesn't control all the XScale PXA270 voltages. The other voltages (VCC\_LCD, VCC\_MEM, VCC\_IO, VCC\_BB, VCC\_USB) are controlled directly by a MOS switch from main +3.3 Vdc power supply.

## Ethernet Controller

The ConnectCore XP 270 module provides an Ethernet connection (Link + PHY Layer) directly on the module board. This connection is made with the LAN91C111 chip from SMSC.

These are features of the chip:

- 10/100 non-PCI Ethernet Single Chip Ethernet Controller (MAC + PHY)
- Fully supports Full Duplex Switched Ethernet
- Supports burst data transfer
- 8 Kbytes internal memory for receive and transmit FIFO buffers
- Supports 16 and 32-bit CPU accesses
- Internal 32 bit wide data path (into packet buffer memory)
- 3.3V operation with 5V tolerant I/O buffers
- Single 25 MHz reference clock for both PHY and MAC
- 128-pin TQFP package, 1.0 mm height
- Industrial temperature range from -40° C to 85° C
- Fully integrated IEEE 802.3/802.3u - 100BASE-TX/10BASE-T physical layer
- Auto negotiation: 10/100, full/half duplex
- LED outputs (user selectable, up to 2 LED functions at one time): link, activity, full duplex, 10/100, transmit, and receive

The Intel PXA270 processor CS1# signal enables accesses to the Ethernet Controller chip. Although the chip can be accessed in 8, 16, and 32-bit accesses, ConnectCore XP 270 has been designed to support only 16-bit and 32-bit accesses.

The memory area reserved for the ConnectCore XP 270 Ethernet Controller is 0x0400 0300 to 0x0400 030F. Accesses to the chip are made with the PXA270 processor's VLIO (Variable Latency) interface. LAN91C111 has no special external EEPROM, but receive the MAC address from the 1-wire EEPROM.

The LAN91C111 interrupt pin is connected to the PXA270 processor GPIO90 pin.

## External schematics for SMSC LAN91C111 Ethernet Controller

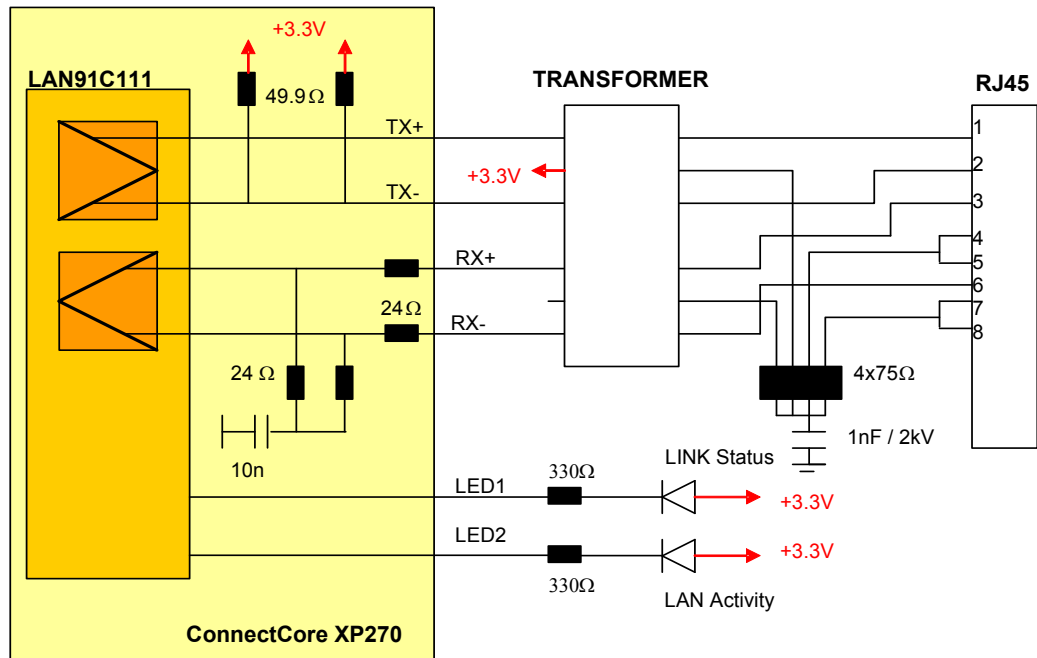

This diagram shows the external components needed for implementing Ethernet connectivity on a product based on the ConnectCore XP 270 module. SMSC has a reference design for their LAN91C111 chip (see <http://www.smsc.com>). SMSC also provides an application note, where suggested magnetics are listed (application note 8- 13).

The most important component is the isolation transformer module. Because the ConnectCore XP 270 uses a supply voltage of 3.3V, a transformer module with a 1:1 ratio between the primary and the secondary windings on the receive side and a ratio of 1:1 for the Tx path must be used.

These are recommended transformers; this information comes from SMSC application note 8-13.

Qualified Magnetics(*)				
Vendor	Part number	Package	Temperature	Configuration
Halo	TG110-S050N2	16-pin SOIC	0-+70°C	Auto MDIX
Pulse	J1012F21C	Integrated RJ45	0-+70°C	10/100 Legacy
Suggested Magnetics(**)				
Vendor	Part	Number	Package	Temperature
Halo	TG22-3506NL	16-pin SOP	0-+70°C	10/100 Legacy
Halo	TG22-3506ND	16-pin SOP	0-+70°C	10/100 Legacy
Halo	TG110-S055N2	16-pin SOIC	0-+70°C	Auto MDIX
Halo	TG110-S050P1	CardBus	0-+70°C	Single channel
Halo	TG110-S050P2	CardBus	0-+70°C	Auto MDIX
Halo	TG110-S050J2	CardBus	0-+70°C	Auto MDIX
Halo	TG110-E050N5	16-pin SOIC	-40-+85°C	Auto MDIX
Halo	TG110-E055N5	16-pin SOIC	-40-+85°C	Auto MDIX
Pulse	H1086	16-pin SOP	0-+70°C	10/100 Legacy
Pulse	H1012	16-pin SOP	0-+70°C	10/100 Legacy
Pulse	PE-68515L	16-pin SOP	0-+70°C	10/100 Legacy
Pulse	H1089	16-pin SOP	0-+70°C	10/100 Legacy
Pulse (Valor)	ST6118T	16-pin SOP	0-+70°C	10/100 Legacy
Pulse	H1102	16-pin SOIC	0-+70°C	Auto MDIX
Pulse	J1012F01C	Integrated RJ45	0-+70°C	10/100 Legacy
Pulse	HX1188	16-pin SOIC	-40-+85°C	Auto MDIX
Pulse	HX1198	16-pin SOIC	-40-+85°C	Auto MDIX
Bel Fuse	S558-5999-U7	16-pin SOIC	0-+70°C	Auto MDIX
Bel Fuse	0810-1X1T-03	Integrated RJ45	0-+70°C	10/100 Legacy

Suggested Magnetics(**) continued				
Bel Fuse	0817-1G1T-21	Integrated RJ45	0-+70°C	Auto MDIX
YCL	20PMT04	16-pin SOP	0-+70°C	10/100 Legacy
YCL	PH163112	16-pin SOIC	+25°C	Auto MDIX
Midcom	000-6241-37R	16-pin SOP	-40-+85°C	10/100 Legacy
Midcom	000-6181-37R	16-pin SOP	-40-+85°C	10/100 Legacy
Midcom	JFM24111-0101	Integrated RJ45	0-+70°C	Auto MDIX
PCA	EPF8033GM	16-pin SOP	0-+70°C	10/100 Legacy
PCA	EPF8143S	16-pin SOIC	0-+70°C	Auto MDIX
Tamura	TTC-8139	16-pin SOIC	0-+70°C	Auto MDIX

**\* Qualified Magnetics:** Magnetics listed under this heading have been tested to verify proper operation with LAN91C111. The testing has been either formal UNH 100BASE-TX PMD testing, UNH 10BASE-T MAU testing, and/or in-house testing performed by SMSC. You can presume with a high degree of confidence, that with proper PCB design techniques, the combinations of SMSC devices and magnetics presented in this category will perform to the highest standards.

**\*\* Suggested Magnetics:** Magnetics listed under this heading have not been tested to verify proper operation with LAN91C111. This category of magnetic has been evaluated by the contents of the vendor-supplied data sheet and legacy performance only. You can presume, however, with some degree of confidence, that with proper PCB design techniques, the combinations of SMSC LAN91C111 and magnetics presented in this category will perform to high standards.

## 1-Wire EEPROM

The ConnectCore XP 270 module comes with the Dallas Semiconductor DS2431 1-wire EEPROM memory chip. This chip is mainly used for storing the ConnectCore XP 270 MAC address for the LAN91C111 Ethernet Controller.

The memory chip also provides these features:

- 1024-bit EEPROM memory organized as four memory pages of 256 bits each.
- Memory pages that can be individually write-protected or put in EPROM-emulation mode
- 8-byte scratch pad
- Communication over the single-conductor 1-wire bus. Communication follows standard Dallas Semiconductor 1-wire protocol.
- Communication with Host with a single digital signal at 15.4kbps or 111kbps using the 1-wire protocol
- Its own unalterable and unique 64-bit ROM registration number that is factory lasered into the chip

The DS2431 is a 1024-bit 1-wire EEPROM chip organized as four memory pages of 256-bit each. Data is written to an 8-byte scratch pad, verified and then copied to the EEPROM memory.

The ConnectCore XP 270 module uses GPIO87 for “bit-toggling” and implementing the 1-wire protocol to communicate with this device. For more information, see the DS2431 datasheet.

This table shows the 1-wire EEPROM memory map:

Address range	Type	Description	Protection codes
0x000–0x001F	R/(W)	Data Memory Page 0 Used for MAC ADDRESS	
0x0020–0x003F	R/(W)	Data Memory Page 1	
0x0040–0x005F	R/(W)	Data Memory Page 2	
0x0060–0x007F	R/(W)	Data Memory Page 3	
0x0080	R/(W)	Protection Control Byte Page 0	0x55: Write Protect 0xAA: EPROM mode 0x55 or 0xAA: Write protect 0x80
0x0081	R/(W)	Protection Control Byte Page 1	0x55: Write Protect 0xAA: EPROM mode 0x55 or 0xAA: Write protect 0x81

Address range	Type	Description	Protection codes
0x0082	R/(W)	Protection Control Byte Page 2	0x55: Write Protect 0xAA: EPROM mode 0x55 or 0xAA: Write protect 0x82
0x0083	R/(W)	Protection Control Byte Page 3	0x55: Write Protect 0xAA: EPROM mode 0x55 or 0xAA: Write protect 0x83
0x0084	R/(W)	Copy protection byte	0x55 or 0xAA: Copy protect 0x0080:0x008F and any other write-protected pages
0x0085	R	Factory byte. Set at factory.	0xAA: Write protect 0x85, 0x86, 0x87 0x55: Write protect 0x85, unprotect 0x86 and 0x87
0x0086	R/(W)	User byte / Manufacturer ID	
0x0087	R/(W)	User byte / Manufacturer ID	
0x0088–0x008F	N/A	Reserved	

## USB

Both the Intel PXA270 and the ConnectCore XP 270 use USB controllers.

### *Intel PXA270 USB*

The Intel PXA270 has one USB Client Port and three USB Host Ports.

#### **USB Host Ports**

- USB Host, Port 1 (Dedicated Port) - Differential
- USB Port 2 is a multiplexed-port and can be used on single-ended and differential signals. The Port 2 transceiver has internal pull-up/pull-down resistors, so you don't need external resistors for the Client (pull-up) and Host (pull-down).
- USB Host, Port 3 (Dedicated Port) - Single-Ended

#### **USB Client Controller features**

- USB Revision 1.1 compliant full-speed device, 12 Mbps, half duplex
- Support 24 endpoints (endpoint 0 plus 26 programmable endpoints).

**USB Host Controller features**

- USB Revision 1.1 compatible
- Supports both low-speed and full-speed USB Devices
- Open Host Controller Interface (OHCI) Rev 1.0a compatible
- Root hub supports two downstream ports

**USB On-The-Go operation**

The processor USB Device and Host controllers provide A- and B-device On-The-Go (OTG) operation as specified in the “On-The-Go Supplement to the USB 2.0 Specification”.

The on-chip OTG transceivers provide on-chip pull-up and pull-down resistors as specified in the “Pull-up / Pull-down Engineering Change Notice to the USB 2.0 Specification”.

OTG operation requires user intervention, but interrupts are provided to notify the user of OTG activities including Vbus changes, session detection, and OTG ID changes. The user must use these interrupts along with the OTG control and status registers to operate as an OTG device.

The USB OTG support includes:

- Decoding SET\_FEATURE commands with OTG specific selector values
- Control for on-chip OTG transceiver with multiplexing between UDC and USB Host Controller Port 2
- Control for on-chip OTG transceiver with multiplexing between UDC and USB Device Controller
- Control, status, and interrupt registers for interfacing to off-chip OTG transceivers
- Control, status, and interrupt registers for interfacing to off-chip charge pump devices
- OTG ID support

***ConnectCore XP 270 USB***

The ConnectCore XP 270 module only has two USB signals (although the Intel XScale PXA270 processor simultaneously supports USB Host and Device).

This diagram shows USB OTG configurations (Intel PXA27x Developer Manual - ordering number 280000-002 / Figure 12-15, USB OTG Configurations):

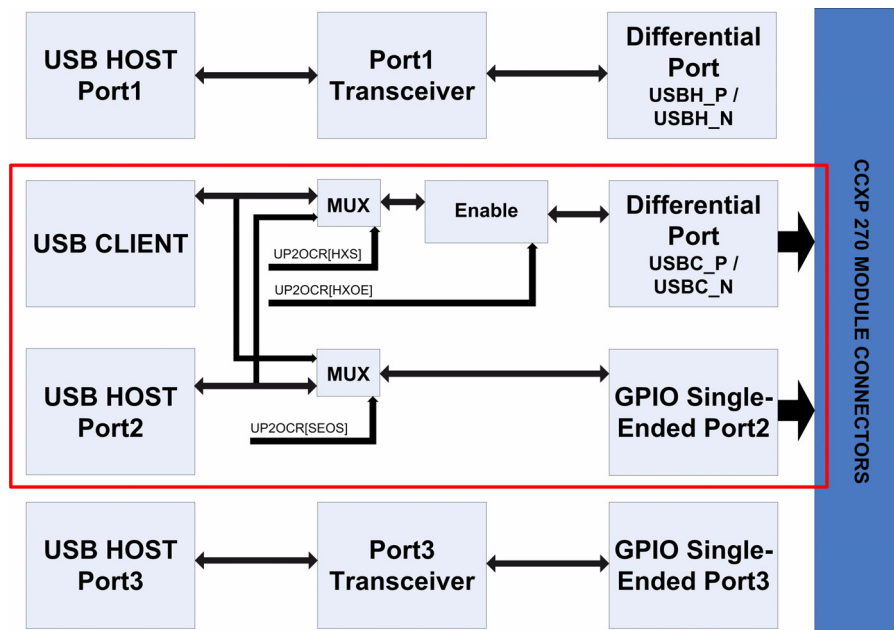

When using USB Client controller and USB Host Port 2, there is access to either the USB Host or the USB Device on USB Client pins. The ConnectCore XP 270 module uses USB Client pins for USB signals, so it is possible to have either USB Host or USB Device on the ConnectCore XP 270 USB pins. USB Power Control (PXA270 USBHPEN signal) and overcurrent indicator (PXA270 USBHPWR signal), however, are not available on the ConnectCore XP 270 module.

In addition, USB Host Controller 2 is also available on GPIOs single-ended Port 2, making it possible to use USB Client on USBC\_P and USBC\_N pin and USB Host (Controller 2) on the single-ended GPIOs. The USB Host 2 single-ended GPIOs are available on the ConnectCore XP 270 module's connector, but they're multiplexed with other main function.

The next table shows the multiplexing mechanism:

<b>USB Host Controller single-ended signal</b>	<b>ConnectCore XP 270 signal, with which it's multiplexed</b>
USB_P2_1	FF_CTS# / GPIO35
USB_P2_2	GPIO34
USB_P2_3	FF_RI# / GPIO38
USB_P2_4	FF_DCD# / GPIO36
USB_P2_5	FF_DTR# / GPIO40
USB_P2_6	FF_TXD / GPIO39
USB_P2_7	FF_RTS# / GPIO41
USB_P2_8	FF_DSR# / GPIO37

If both USB Host and Device must be implemented on the ConnectCore XP 270 module, the following signals need to be sacrificed: FF\_CTS# / GPIO35, GPIO34, FF\_RI# / GPIO38, FF\_DCD# / GPIO36, FF\_DTR# / GPIO40, FF\_TXD / GPIO39, FF\_RTS# / GPIO41 and FF\_DSR# / GPIO37.

With USB single-ended GPIOs you can interface an external OTG transceiver, an external charge pump device, and an external USB transceiver. The drawings on the next pages show details.

**OTG Transceiver (see Intel PXA27x Developer Manual – Ordering Number 280000-002 / Figure 12-17)**

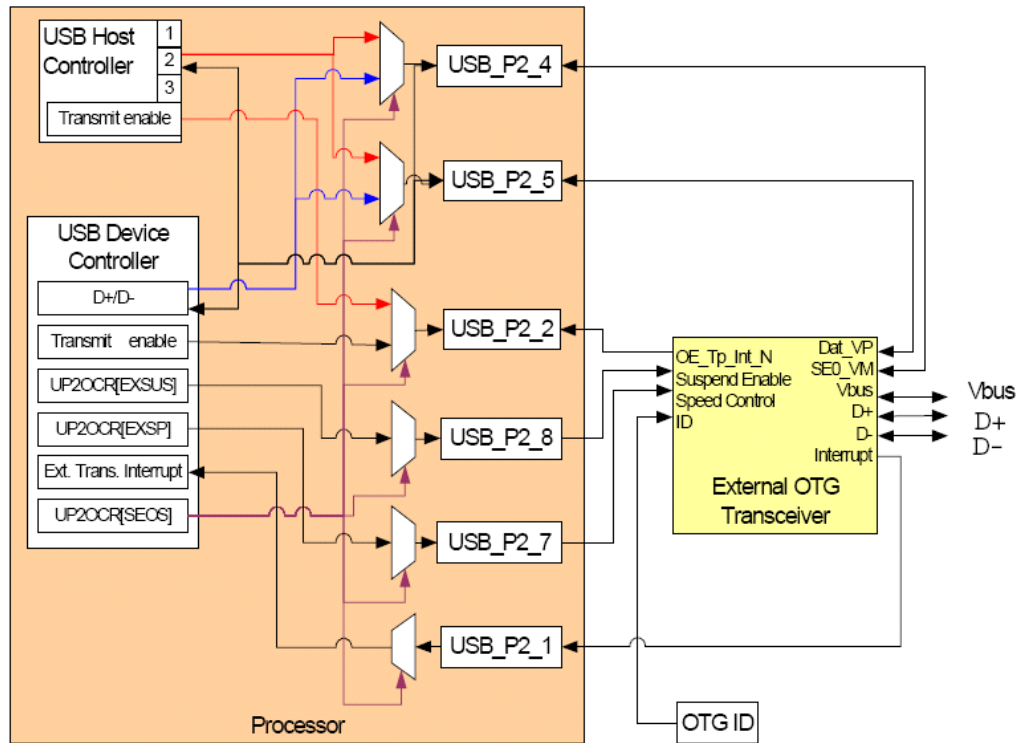

**Charge Pump Device (see Intel PXA27x Developer Manual – Ordering Number 280000-002 / Figure 12-18)**

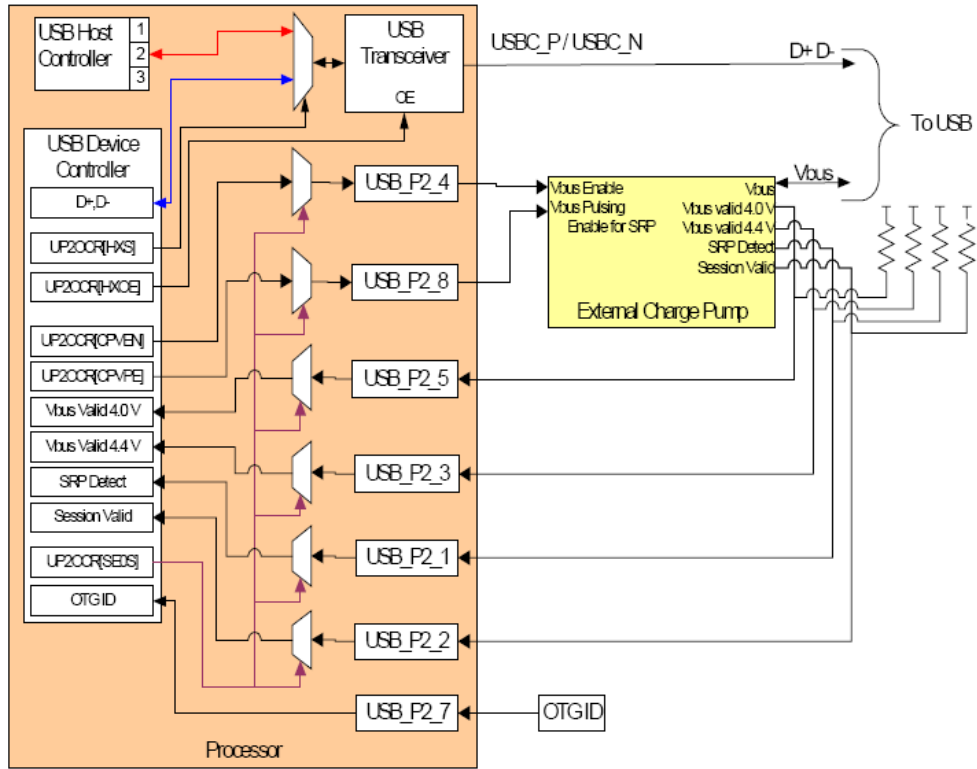

**USB Transceiver (see Intel PXA27x Developer Manual – Ordering Number 280000-002 / Figure 12-19)**

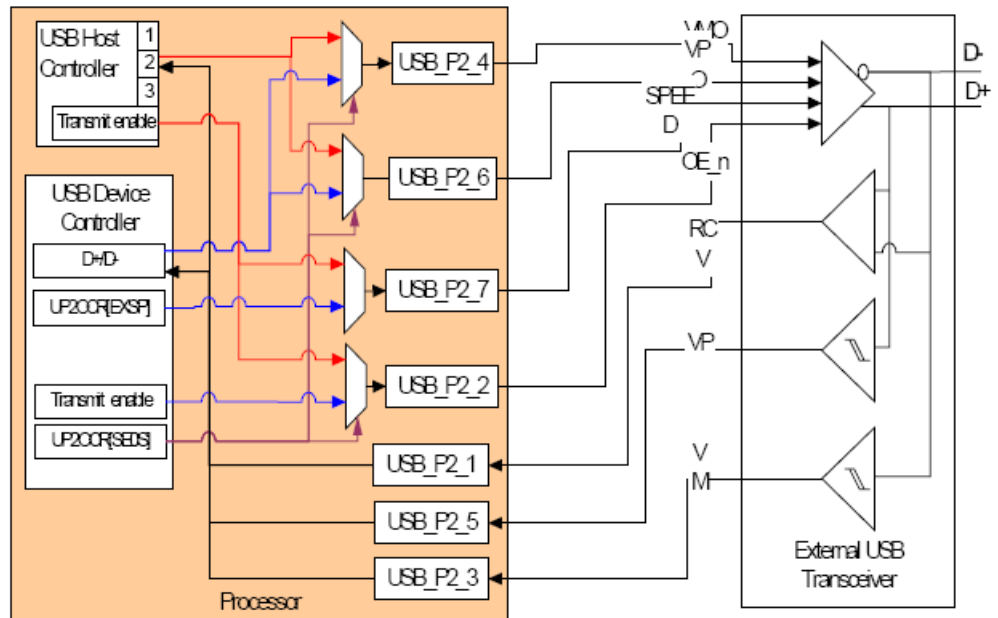

## UARTs

ConnectCore XP 270 has three UARTs: full-function UART (FFUART), Bluetooth UART (BTUART), and IrDA. These features are provided by both UARTs:

- Each serial port operates in either FIFO or non-FIFO mode. In FIFO mode, a 64-byte transmit FIFO holds data from the processor until it's transmitted on the serial link, and a 64-byte receive FIFO buffers data from the serial link until it is read by the processor.
- Functionality compatible with the 16550A and 16750 industry standards.
- Fully programmable serial interface
  - 5-, 6-, 7-, or 8-bit characters
  - Even, odd, and no-parity detection
  - 1, 1<sup>1/2</sup> or 2 stop-bit generation

- Baud-rate generation up to 921 kbps for all UARTs
- False start-bit detection
- Separate DMA requests for transmit and receive data services

## SSP Serial Ports

ConnectCore XP 270 supports two Synchronous Serial Protocol serial ports (SSP and NSSP). The SSP ports are a synchronous serial interfaces that connect to a variety of external analog-to-digital (A/D) converters, audio and telecommunication codecs, and many other devices that use serial protocols for data transfer. The SSP ports provide support for these protocols:

- Texas Instruments (TI) Synchronous Serial Protocol
- Motorola Serial Peripheral Interface (SPI) protocol
- National Semiconductor Microwire
- Programmable Serial Protocol (PSP)

The SSP ports operate as full-duplex devices for TI Synchronous Serial Protocol, SPI and PSP protocols and as a half-duplex device for the Microwire protocol.

The FIFO can be loaded or emptied by the CPU using programmed I/O or by DMA burst transfers.

### *Features*

- One transmit FIFO and one receive FIFO, each 16 samples deep by 32-bits wide
- Sample sizes from 4- to 32-bits
- Bit-rates from 6.3 Kbps (minimum) to 13 Mbps (maximum)
- Master-mode and slave-mode operation
- Receive-without-transmit operation
- Network mode with up to eight time slots and independent transmit/receive in any/all/none of the time slots – available only with TI Synchronous Serial Protocol and Programmable Serial Protocol (PSP) formats
- Audio clock control to provide a 4x output clock and support for selection of most standard audio Codec frequencies

## I<sup>2</sup>C Bus Interface

The PXA270 processor has two I<sup>2</sup>C (Inter-Integrated Circuit) peripherals: the standard I<sup>2</sup>C interface and the power-manager interface (a subset of the standard I<sup>2</sup>C interface). Only the standard I<sup>2</sup>C bus is available externally on the module. The power I<sup>2</sup>C bus is used for controlling the PMIC (Power Management IC).

The I<sup>2</sup>C interface allows the ConnectCore XP 270 to serve as a master and a slave device on the I<sup>2</sup>C bus.

### *Features*

- I<sup>2</sup>C compliant (see the *I<sup>2</sup>C Bus Specification, Version 2.0*)
- Multi-master and arbitration support
- Standard-speed operation @ 100 kbps. Power-I<sup>2</sup>C standard-speed operation is 40 kbps.
- Fast-mode operation @ 400 kbps. Power-I<sup>2</sup>C fast-mode operation is 160 kbps.

## PC Card and CompactFlash Interface

The PC Card interface conforms to the PC Card Standard, Volume 2, Electrical Specification, Version 1.4 and CF+ and CompactFlash Specification Version 1.4. The PC Card and CompactFlash interfaces provide control signals to support one or two PC or CompactFlash card slots.

### *Features*

- 8- or 16-bit transfer possibilities
- Any combination of PC Card and CompactFlash can be used for the two PC Card sockets.
- The PC Card interface supports 8- and 16-bit peripherals and handles common memory, I/O, and attribute memory accesses.

### ***PC Card Memory Map***

0x3C00_0000	Socket 1 Common Memory Space
0x3800_0000	Socket 1 Attribute Memory Space
0x3400_0000	Reserved
0x3000_0000	Socket 1 I/O Space
0x2C00_0000	Socket 0 Common Memory Space
0x2800_0000	Socket 0 Attribute Memory Space
0x2400_0000	Reserved
0x2000_0000	Socket 0 I/O Space

**Note:** If you decide to use the PC Card / Compact Flash Interface on the ConnectCore XP 270, you can't use the MultiMedia Card / SD / SDIO controller since most of their pins are shared on the ConnectCore XP 270 module connector.

### **MultiMedia Card / SD / SDIO Controller + Memory Stick**

The ConnectCore XP 270 MMC/SD/SDIO controller acts as a link between the software that accesses the PXA270 processor and the MMC stack (a set of memory cards), and supports MultiMedia Card, Secure Digital, Secure Digital I/O, and Memory Stick communications protocols.

The MMC controller is based on the standards outlined in the MultiMediaCard System Specification Version 3.2.

The SD controller supports one SD or SDIO card based on the standards outlined in the SD Memory Card Specification Version 1.01 and SDIO Card Specification Version 1.0 (draft 4).

#### ***Features***

- Data-transfer rates up to 19.5 Mbps for MMC, 1-bit SD/SDIO, and SPI mode data transfers
- Data-transfer rates up to 78 Mbps for 4-bit SD/SDIO data transfers
- A response FIFO

- Two transmit FIFOs and two receive FIFOs
- Two modes of operation: MMC/SD/SDIO mode and SPI mode. MMC/SD/SDIO mode support MMC, SD, and SDIO communications protocols. SPI mode supports the SPI communications protocol.
- 1- and 4- bit data transfers are supported for SD and SDIO communications protocols
- Controller turns clock on and off, based on status of FIFOs, to prevent overflows and underruns
- Support for all valid MMC and SD/SDIO protocol data-transfer modes
- Interrupt-based application interface to control software interaction
- Support for multiple MMC cards, using the MMC communications protocol
- Support for one SD or SDIO card, using the SD or SDIO communications protocol
- Support for up to two MMC or SD/SDIO cards, using the SPI communications protocol. Mixed card types are supported for the SPI communications protocol only.

**Note:** If you decide to use MultiMedia Card / SD / SDIO controller on the ConnectCore XP 270, you can't use PC Card / Compact Flash Interface since most of their pins are shared on the ConnectCore XP 270 module connector.

## LCD Controller

The LCD controller provides an interface between the PXA270 processor and a flat-panel display module. The flat-panel display module can be passive (DSTN), active (TFT), or an LCD panel with internal frame buffering (smart panels).

The LCD/flat-panel controller is backward-compatible with Intel PXA250 processor LCD controllers.

### *Features*

- Single- or dual-scan display modules
- Up to 256 gray-scale levels (8 bits) in passive monochrome mode
- Up to 16777216 colors (24 bits) in active color mode

- A total of 16777216 colors (24 bits) in passive color mode
- Up to 8-bit (each) passive dual-scan color displays
- Up to 16-bit per pixel for active single-panel color displays
- Up to 24-bit per pixel single-panel color smart panels
- Support for display sizes from 1x1 to 800x600 pixels
- LCD controller contains a 64-entry x 24-bit wide output FIFO that stores pixel pin data before it is driven out to the pins
- Overlays supported with pixel depths of 16, 24 and 25 bpp in RGBT format
- Provides one base layer plus two overlays for single-scan displays; maximum size of each overlay can equal the display size
- Hardware support for color-space conversion from YCbCr to RGB for video streams
- Support hardware cursor for single-scan display
- Programmable pixel clock from 52.0 MHz to 25.4 kHz
- Supports little-endian ordering of pixels in frame buffer
- Programmable interrupts for input and output FIFOs (underrun)

The color depth determines the number of pins used. All 16 bpp active displays require 16 data lines. All 18 bpp active displays require 18 data lines. Only with 24 bpp does the PXA270 processor use a different number of pins than the color depth; the processor outputs the data on 8 lines.

**Note:** ConnectCore XP 270 only supports externally a 16-bit LCD data bus. LCD[17] and LCD[16] aren't routed on the module's connector due to place availability on the connector. That means it's impossible to implement 18bpp displays with ConnectCore XP 270.

The next diagram shows the Intel PXA270 LCD Controller Unit. For more information, see "Intel PXA27x Processor Family Developer's Manual - Order Number: 280000-002".

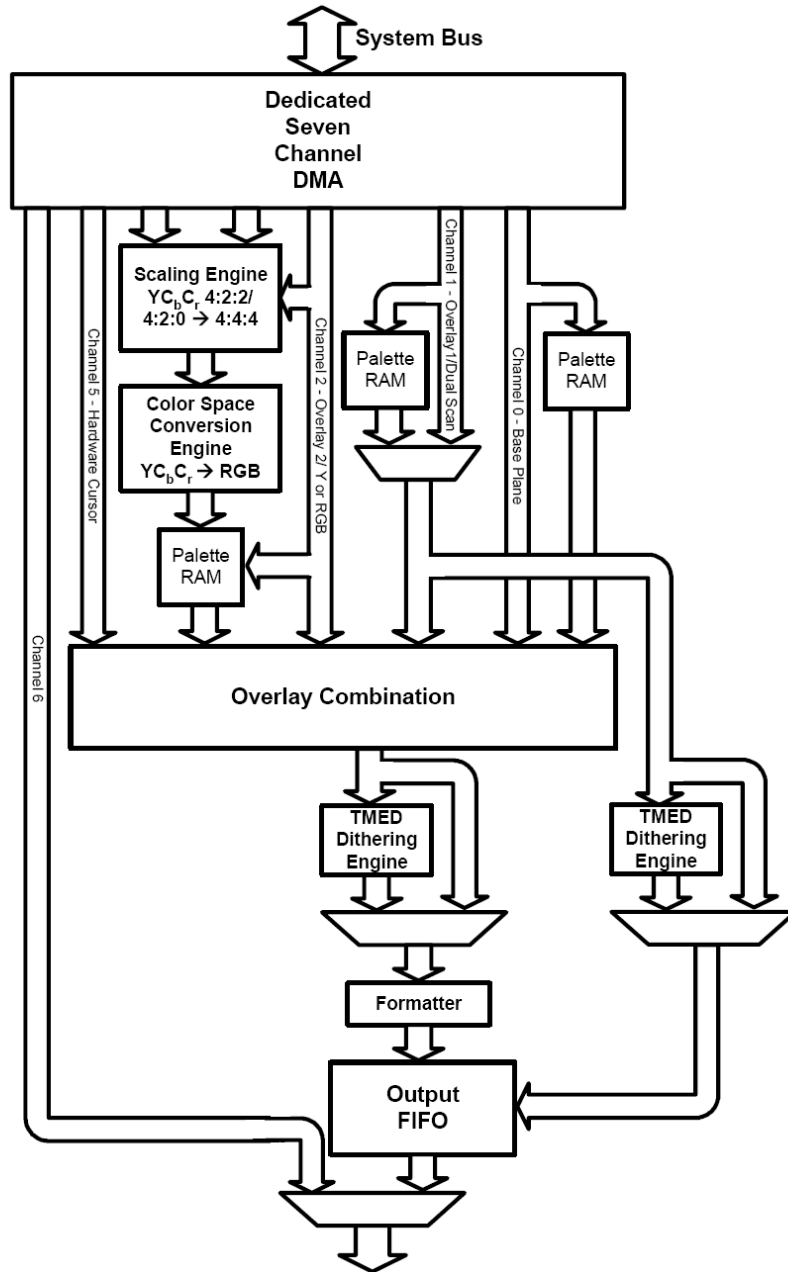

## AC'97 Controller

The ConnectCore XP 270 AC'97 controller supports the “Audio Codec '97 Component Specification, Revision 2.0”. The AC-link is a synchronous, fixed-rate serial bus interface to the digital AC'97 controller for transferring digital audio, modem, microphone input (MIC-in), Codec register control, and status information.

### *Features*

- Independent channels for stereo pulse code modulation (PCM) in, stereo PCM out, modem out, modem-in, and mono MIC-in. All of the channels support only 16-bit samples in hardware. Samples less than 16 bits are supported through software.
- Multiple sample rate AC'97 2.0 Codecs (48 kHz and below). The AC'97 controller depends on the Codec to control the varying rate.
- Secondary Codec support
- Three receive FIFOs (32-bit, 16 entries)
- Two transmit FIFOs (32-bit, 16 entries)
- Optional AC97\_SYCLK output (support for Codecs without oscillators or crystals)

The AC'97 controller does not support the following optional AC'97 Revision 2.0 features:

- Double-rate sampling (n+1 sample for PCM L, R and C)
- 18- and 20-bit sample lengths

## Pulse Width Modulator Controller

ConnectCore XP 270 provides two PWM outputs. Each PWM operates independently of the other. In general, the PWM controller provides a basic digital-to-analog converter with an appropriate analog filter; for example, controlling the brightness of an LED output or controlling LCD contrast.

**Features (short list):**

- Enhanced period control through 6-bit clock divider and 10-bit period counter
- 10-bit pulse control

## Connector pinout

---

The ConnectCore XP 270 module is supplied with two Samtec LTH connectors on the bottom of the board. The connectors are double row with 50 pins per row; the module uses the surface-mounted version.

Samtec serial number: LTH-050-01-G-D-A-K

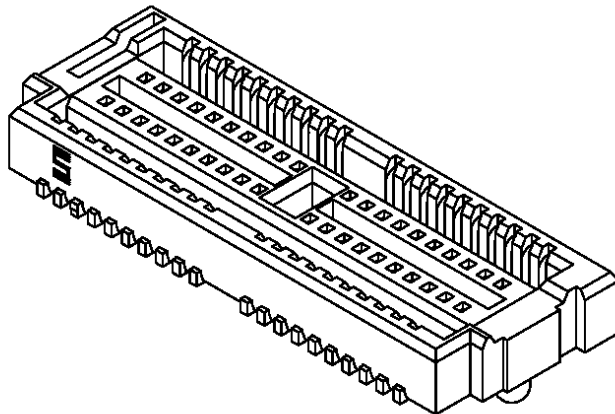

### ConnectCore XP pinouts: Connector X1

The first value is the SMT connector pin and the second value (if there is one), in **bold green**, is the PXA270 processor pin. In the signal column, the values written in black and normal font are features used by the processor. The *italic red values* are additional features – available on the ConnectCore XP pin, but not standard features for the module.

Pin	Signal	Description	Pin	Signal	Description
1 / <b>D12</b>	BITCLK / GPIO28 / <i>I2S_BITCLK / SSPSFRM</i>	AC97 Audio Port bit clock (output)	2	ETN_TX-	Ethernet Transmit-
3		Reserved	4	ETN_TX+	Ethernet Transmit+
5 / <b>AB17</b>	SDATA_IN1 / GPIO99 / <i>KP_DKIN6 / KP_MKIN5 / FFTXD</i>	AC97 Audio Port Data In	6	ETN_RX-	Ethernet Receive-
7 / <b>A10</b>	AC97_RESET#/ GPIO113 / <i>I2S_SYSCLK / USB_P3_3</i>	AC97 Audio Port Reset	8	ETN_RX+	Ethernet Receive+
9 / <b>B11</b>	AC97_SDATA_ OUT / GPIO30 / <i>I2S_SDATA_OU T / USB_P3_2</i>	AC97 Audio Port Data out	10	ETNLED1	Ethernet LED1
<b>11</b>	<b>GND</b>	<b>GND</b>	<b>12</b>	<b>GND</b>	<b>GND</b>
13 / <b>C11</b>	AC97_SYNC / GPIO31 / <i>I2S_SYNC / USB_P3_6</i>	AC97 Audio Port Sync	14	ETNLED2	Ethernet LED2
15 / <b>A11</b>	AC97_SDATA_I N0 / GPIO29 / <i>SSPRXD2 / I2S_SDTA_IN / SSPSCLK</i>	A C97 Audio Port Data IN	16 / <b>D15</b>	PWM1 / GPIO17 / <i>KP_MKIN6 / CIF_DD6</i>	Pulse Width Modulation Channel 1
17 / <b>C14</b>	PWM0 / GPIO16 / <i>KP_MKIN5 / FFTXD</i>	Pulse Width Modulation Channel 0	18 / <b>A15</b>	SSPTXD / GPIO25 / <i>CIF_LV</i>	Synchronous Serial Port Transmit Pin
19 / <b>A14</b>	SSPRXD / GPIO26 / <i>CIF_PCLK / FFCTS</i>	Synchronous Serial Port Receive Pin	20 / <b>B14</b>	SSPSFRM / GPIO24 / <i>CIF_FV</i>	Synchronous Serial Port Frame Pin
21 / <b>A16</b>	SSPSCLK / GPIO23 / <i>CIF_MCLK</i>	Synchronous Serial Port Clock Pin	22 / <b>R20</b>	TMS	JTAG test mode select. TMS has an internal 10 kΩ pullup resistor.

Pin	Signal	Description	Pin	Signal	Description
23 / <b>R21</b>	TDO	JTAG test data out. TDO has an internal 10 kΩ pullup resistor.	24 / <b>T20</b>	TRST#	JTAG test reset. The TRST# signal is connected internally with PXA270 reset input signal through a 22 kΩ series resistor. TRST# has an internal 10 kΩ pullup resistor.
25 / <b>R19</b>	TCK	JTAG test clock. TCK has an internal 10 kΩ pullup resistor	26 / <b>W20</b>	RESET_IN#	Reset Input
27 / <b>R22</b>	TDI	JTAG test data in. TDI has in internal 10 kΩ pullup resistor.	28 / <b>W21</b>	RESET_OUT#	Reset output
<b>29</b>	<b>GND</b>	<b>GND</b>	<b>30</b>	<b>GND</b>	<b>GND</b>
31 / <b>U19</b>	BATT_FAULT#	Battery fault	32	Reserved	Reserved
33 / <b>U20</b>	GPIO0	General purpose I/O	34 / <b>D20</b>	BTRXD / GPIO42 / <i>ICP_RXD / CIF_MCLK</i>	Bluetooth UART receive
35 / <b>U21</b>	GPIO1	General purpose I/O	36 / <b>B21</b>	BTTXD / GPIO43 / <i>ICP_TXD / CIF_FV</i>	Bluetooth UART transmit
37 / <b>AB19 / A17</b>	PIOIS16# / GPIO57 / <i>BB_IB_DAT3 / SSPTXD / GPIO111 / MMDAT3 / MMCCSI</i>	PCMCIA I/O Select 16 bit	38 / <b>A20</b>	BTCTS / GPIO44 / <i>CIF_LV</i>	Bluetooth UART Clear to Send
39 / <b>AB8 / C15</b>	PWAIT# / GPIO56 / <i>USB_P3_4 / BB_IB_DAT2 / GPIO110 / MMDAT2 / MSSCLK</i>	PCMCIA Socket Select	40 / <b>C17</b>	BTRTS / GPIO45 / <i>AC97_SYS CLK / SSPSYCLK3 / CIF_PCLK</i>	Bluetooth UART Ready to Send

Pin	Signal	Description	Pin	Signal	Description
41 / <b>W14</b> / <b>C16</b>	PSKTSEL / GPIO104 / <i>CIF_DD2</i> / <i>KP_MKOUT1</i> / <i>GPIO32</i> / <i>MMCLK</i> / <i>MSSCLK</i>	PCMCIA socket select	42 / <b>AA12</b>	FFRXD / GPIO53 / <i>USB_P2_3</i> / <i>BB_OB_STB</i> / <i>CIF_MCLK</i> / <i>SSPSYSCLK</i>	Full function UART receive pin
43 / <b>AB12</b> / <b>A18</b>	PIOW# / GPIO51 / <i>CIF_DD2</i> / <i>BB_OB_DAT3</i> / <i>GPIO92</i> / <i>MMDAT0</i> / <i>MSBS</i>	PCMCIA I/O Write	44 / <b>B17</b>	FFTXD / GPIO39 / <i>KP_MKIN4</i> / <i>USB_P2_6</i> / <i>SSPSFRM3</i>	Full function UART transmit pin
45 / <b>AB13</b>	PCE2# / GPIO54 / <i>CIF_PCLK</i> / <i>BB_OB_WAIT</i>	PCMCIA high byte enable. PCE2# has an internal 10 kΩ pullup resistor.	46 / <b>B13</b>	FFDCD / GPIO36 / <i>USB_P2_4</i> / <i>SSPCLK2</i> / <i>KP_MKIN7</i>	Full function UART Carrier Detect pin
47 / <b>W12</b> / <b>B16</b>	PIOR# / GPIO50 / <i>CIF_DD3</i> / <i>BB_OB_DAT2</i> / <i>SSPCLK2</i> / <i>GPIO112</i> / <i>MMCMD</i> / <i>MSINS#</i>	PCMCIA I/O read	48 / <b>D17</b>	FFCTS / GPIO35 / <i>USB_P2_1/KP</i> <i>_MKOUT6</i> / <i>SSPTXD3</i> / <i>SSPSFRMS</i>	Full function UART Clear to Send pin
<b>49</b>	<b>+3.3V</b>	<b>Power supply</b>	<b>50</b>	<b>+3.3V</b>	<b>Power supply</b>
<b>51</b>	<b>+3.3V</b>	<b>Power supply</b>	<b>52</b>	<b>+3.3V</b>	<b>Power supply</b>
53 / <b>AA8</b>	NSSP_RXD (SSPRXD3) / GPIO82 / <i>BB_IB_DAT0</i> / <i>CIF_DD5</i> / <i>FFDTR</i>	NSSP Interface, RxD	54 / <b>A13</b>	FFRI / GPIO38 <i>SSPTXD3</i> / <i>KP_MKIN4</i> / <i>SSPTXD2</i> / <i>USB_P2_3</i> / <i>PWMI</i>	Full Function UART Ring Indicator Pin
55 / <b>Y10</b>	NSSP_CLK (SSPCLK3 / <i>GPIO84</i> / <i>BB_IB_STB</i> / <i>CIF_FV</i>	NSSP Interface, CLK	56 / <b>D13</b>	FFDSR / GPIO37 / <i>USB_P2_8</i> / <i>SSPSFRM2</i> / <i>KP_MKIN3</i> / <i>FFTXD</i>	Full Function UART Data Set Ready Pin

Pin	Signal	Description	Pin	Signal	Description
57 / <b>W10</b>	NSSP_TXD (SSPTXD3) / GPIO81 / <i>BB_OB_DAT0 / CIF_DD0</i>	NSSP Interface, TxD	58 / <b>C12</b>	FFDTR / GPIO40 / <i>SSPRXD2 / KP_MKOUT6 / USB_P2_5 / SSPCLK3</i>	Full Function UART Data Term Ready Pin
59 / <b>AB10</b>	NSSP_FRAME (SSPSFRM3) / GPIO83 / <i>BB_IB_CLK / FFTXD / CIF_DD4 / FFRTS</i>	NSSP Interface, Frame	60 / <b>A19</b>	FFRTS / GPIO41 / <i>FFRXD / KP_MKOUT7 / USB_P2_7 / SSPRXD3</i>	Full Function UART Ready to Send Pin
<b>61</b>	<b>GND</b>	<b>GND</b>	<b>62</b>	<b>GND</b>	<b>GND</b>
63 / <b>E19</b>	USB_N	USB port negative	64 / <b>P21</b>	L_BIAS / GPIO77	LCD bias drive
65 / <b>D18</b>	USB_P	USB port positive	66 / <b>L20</b>	LDD13 / GPIO71	LCD data bus
67 / <b>B20</b>	SDA / GPIO118	I2C data signal. SDA has an internal 2.2 kΩ pullup resistor.	68 / <b>K19</b>	LDD9 / GPIO67	LCD data bus
69 / <b>C18</b>	SCL / GPIO117	I2C clock signal. SCL has an internal 2.2 kΩ pullup resistor.	70 / <b>F22</b>	LDD3 / GPIO61	LCD data bus.
71 / <b>N20</b>	L_LCLK / GPIO75	LCD line clock	72 / <b>J19</b>	LDD8 / GPIO66	LCD data bus
73 / <b>H20</b>	LDD1 / GPIO59	LCD data bus	74 / <b>N21</b>	L_PCLK / GPIO76	LCD pixel clock
<b>75</b>	<b>GND</b>	<b>GND</b>	<b>76</b>	<b>GND</b>	<b>GND</b>
77 / <b>G21</b>	LDD2 / GPIO60	LCD data bus	78 / <b>J22</b>	LDD11 / GPIO69	LCD data bus
79 / N 2 2	L_FCLK / GPIO74	LCD frame clock	80 / <b>K22</b>	LDD12 / GPIO70	LCD data bus
81 / <b>J20</b>	LDD5 / GPIO63	LCD data bus	82 / <b>K21</b>	LDD10 / GPIO68	LCD data bus
83 / <b>L21</b>	LDD14 / GPIO72	LCD data bus	84 / <b>L22</b>	LDD15 / GPIO73	LCD data bus

Pin	Signal	Description	Pin	Signal	Description
85 / <b>G20</b>	LDD0 / GPIO58	LCD data bus	86 / <b>K20</b>	LDD7 / GPIO65	LCD data bus
<b>87</b>	<b>GND</b>	<b>GND</b>	<b>88</b>	<b>GND</b>	<b>GND</b>
89 / <b>H22</b>	LDD6 / GPIO64	LCD data bus	90 / <b>A9</b>	IR_RXD_ / GPIO46 / <i>STD_RXD / PWM_OUT2</i>	IrDA Receive pin
91 / <b>G22</b>	LDD4 / GPIO62	LCD data bus	92 / <b>C10</b>	IR_TXD / GPIO47 / <i>CIF_DD0 / STD_TXD / PWM_OUT3</i>	IrDA Transmit pin
93 / <b>AA10</b>	PCE1# / GPIO85 / <i>FFRXD / DREQ2 / BB_IB_WAIT / CIF_LV</i>	PCMCIA Low Byte Enable. PCE1# has an internal 10 kΩ pullup resistor.	94 / <b>B19</b>	GPIO34 / <i>FFRXD / KP_MKIN3 / SSPCLK3 / USB_P2_2</i>	General purpose I/O
95 / <b>Y11</b>	POE# / GPIO48 / <i>CIF_DD5 / BB_OB_DAT1</i>	PCMCIA Output Enable	96 / <b>U22</b>	GPIO10 / <i>FFDCD / HZ_CLK / USB_P3_5 / CHOUT1</i>	General purpose I/O
97 / <b>W9 / D16</b>	PREG# / GPIO55 / <i>CIF_DD1 / BB_IB_DAT1 / GPIO109 / MMDAT1 / MSSDIO</i>	PCMCIA Register Select	98 / <b>D10</b>	PWE# / GPIO49	PCMCIA Write Enable
<b>99</b>	<b>GND</b>	<b>GND</b>	<b>100</b>	<b>GND</b>	<b>GND</b>

## ConnectCore XP pinouts: Connector X2

The first value is the SMT connector pin and the second value (if there is one), in **bold green**, is the PXA270 processor pin. In the signal column, the values written in black and normal font are features used by the processor. The *italic red values* are additional features – available on the ConnectCore XP pin, but not standard features for the module.

Pin	Signal	Description	Pin	Signal	Description
<b>1</b>	<b>GND</b>	<b>GND</b>	<b>2</b>	<b>GND</b>	<b>GND</b>
3 / <b>C8</b>	RD/WR#	Read not Write	4 / <b>AA3</b>	WE#	Memory write enable
5 / <b>W7</b>	SDCKE1#	SDRAM device clock enable	6 / <b>AA4</b>	OE#	Memory output enable
7 / <b>W13</b>	SDCKE0# / GPIO106 / <b>CIF_DD9 / KP_MKOUT3</b>	SMROM or synchronous flash clock enable	8 / <b>D9</b>	RDY / GPIO18	Ready pin
9 / <b>AB3</b>	SDCLK0	SMROM or synchronous flash clock. SDCLK0 has an internal 22 $\Omega$ series resistor.	10 / <b>D8</b>	CS2# / GPIO78 / <b>PCE2#</b>	Chip select. CS2# has an internal 10 k $\Omega$ pullup resistor.
<b>11</b>	<b>GND</b>	<b>GND</b>	<b>12</b>	<b>GND</b>	<b>GND</b>
13 / <b>AB4</b>	SDCLK2	SDRAM banks 2/3 clock. SDCLK2 has an internal 22 $\Omega$ series resistor.	14 / <b>A5</b>	CS3# / GPIO79 / PSKTSEL / PWM2	Chip select. CS3# has an internal 10 k $\Omega$ pullup resistor.
15 / <b>Y6</b>	SDCS3# / GPIO21 / <b>DVAL0 / MBGNT</b>	SDRAM Chip Select for Banks 3	16 / <b>D7</b>	CS4# / GPIO80 / <b>DREQ1 / MBREQ / PWM3</b>	Chip Select. CS4# has an internal 10 k $\Omega$ pullup resistor.
17 / <b>W5</b>	SDCS2# / GPIO20 / <b>DREQ0 / MBREQ</b>	SDRAM Chip Select for Banks 2	18 / <b>C7</b>	CS5# / GPIO33 / <b>DVAL1 / FFRXD / FFDSR / MBGNT</b>	Chip Select. CS5# has an internal 10 k $\Omega$ pullup resistor.
19 / <b>Y4</b>	SDCAS	SDRAM column address strobe. SDCAS has an internal 22 $\Omega$ series resistor.	20 / <b>V4</b>	MD16	Memory data bus
<b>21</b>	<b>GND</b>	<b>GND</b>	<b>22</b>	<b>GND</b>	<b>GND</b>
23 / <b>W6</b>	SDRAS#	SDRAM row address strobe	24 / <b>Y2</b>	MD17	Memory data bus
25 / <b>AB7</b>	DQM3	Data output byte enable 3	26 / <b>W2</b>	MD18	Memory data bus

Pin	Signal	Description
27 / <b>AB6</b>	DQM2	Data output byte enable 2
29 / <b>AA7</b>	DQM1	Data output byte enable 1
31 / <b>W8</b>	DQM0	Data output byte enable 0
<b>33</b>	<b>GND</b>	<b>GND</b>
35 / <b>A3</b>	MA25	Memory address bus
37 / <b>C4</b>	MA24	Memory address bus
39 / <b>E4</b>	MA23	Memory address bus
41 / <b>D4</b>	MA22	Memory address bus
<b>43</b>	<b>GND</b>	<b>GND</b>
45 / <b>E3</b>	MA21	Memory address bus
47 / <b>F4</b>	MA20	Memory address bus
49 / <b>D3</b>	MA19	Memory address bus
51 / <b>G4</b>	MA18	Memory address bus
<b>53</b>	<b>GND</b>	<b>GND</b>
55 / <b>C2</b>	MA17	Memory address bus
57 / <b>C1</b>	MA16	Memory address bus
59 / <b>E21</b>	DREQ0 / GPIO115 / <i>UEN / UVSI# / PWM1 / MBREQ / CIF_DD3</i>	DMA Request Channel 0
61 / <b>D2</b>	MA15	Memory address bus
63 / <b>D1</b>	MA14	Memory address bus
65 / <b>G3</b>	MA13	Memory address bus
67 / <b>E2</b>	MA12	Memory address bus
<b>69</b>	<b>GND</b>	<b>GND</b>
71 / <b>E1</b>	MA11	Memory address bus

Pin	Signal	Description
28 / <b>W1</b>	MD19	Memory data bus
30 / <b>V1</b>	MD20	Memory data bus
32 / <b>R3</b>	MD21	Memory data bus
<b>34</b>	<b>GND</b>	<b>GND</b>
36 / <b>U1</b>	MD22	Memory data bus
38 / <b>R2</b>	MD23	Memory data bus
40 / <b>N3</b>	MD24	Memory data bus
42 / <b>N4</b>	MD25	Memory data bus
<b>44</b>	<b>GND</b>	<b>GND</b>
46 / <b>N2</b>	MD26	Memory data bus
48 / <b>P1</b>	MD27	Memory data bus
50 / <b>N1</b>	MD28	Memory data bus
52 / <b>L3</b>	MD29	Memory data bus
<b>54</b>	<b>GND</b>	<b>GND</b>
56 / <b>K2</b>	MD30	Memory data bus
58 / <b>K4</b>	MD31	Memory data bus
60 / <b>Y15</b>	DREQ1 / GPIO97 / <i>KP_DKIN4 / MBGNT / KP_MKIN3</i>	DMA Request Channel 1
62 / <b>K1</b>	MD15	Memory data bus
64 / <b>R4</b>	MD7	Memory data bus
66 / <b>L1</b>	MD14	Memory data bus
68 / <b>U2</b>	MD6	Memory data bus
<b>70</b>	<b>GND</b>	<b>GND</b>
72 / <b>M1</b>	MD13	Memory data bus

Pin	Signal	Description	Pin	Signal	Description
73 / <b>H4</b>	MA10	Memory address bus	74 / <b>T4</b>	MD5	Memory data bus
75 / <b>F1</b>	MA9	Memory address bus	76 / <b>M4</b>	MD12	Memory data bus
77 / <b>G2</b>	MA8	Memory address bus	78 / <b>U3</b>	MD4	Memory data bus
<b>79</b>	<b>GND</b>	<b>GND</b>	<b>80</b>	<b>GND</b>	<b>GND</b>
81 / <b>G1</b>	MA7	Memory address bus	82 / <b>M2</b>	MD11	Memory data bus
83 / <b>J3</b>	MA6	Memory address bus	84 / <b>Y1</b>	MD3	Memory data bus
85 / <b>J4</b>	MA5	Memory address bus	86 / <b>R1</b>	MD10	Memory data bus
87 / <b>H1</b>	MA4	Memory address bus	88/U4	MD2	Memory data bus
<b>89</b>	<b>GND</b>	<b>GND</b>	<b>90</b>	<b>GND</b>	<b>GND</b>
91 / <b>J1</b>	MA3	Memory address bus	92 / <b>T1</b>	MD9	Memory data bus
93 / <b>J2</b>	MA2	Memory address bus	94 / <b>W3</b>	MD1	Memory data bus
95 / <b>B5</b>	MA1	Memory address bus	96 / <b>P4</b>	MD8	Memory data bus
97 / <b>D5</b>	MA0	Memory address bus	98 / <b>W4</b>	MD0	Memory data bus
<b>99</b>	<b>GND</b>	<b>GND</b>	<b>100</b>	<b>GND</b>	<b>GND</b>

## ConnectCore XP 270 GPIOs

Most of the peripheral pins on the ConnectCore XP module also double (or triple) as GPIO pins.

- As inputs, the GPIO pins can be sampled or programmed to generate an interrupt from either a rising or falling edge.
- As outputs, the GPIO pins can be cleared or set individually and can be preprogrammed to either state when entering sleep mode.

Each GPIO can be configured to be either a generic GPIO pin, one of three alternate input functions, or one of three alternate output functions. To select any of the alternate functions, the GPDR register must configure the GPIO to be an input.

Similarly, only GPIOs configured as outputs by the GPDR can be configured for alternate output functions.

## Bidirectional GPIOs

MMCMD, MMDAT[1:0], MMDAT[2] / MMCCS[0], MMDAT[3] / MMCCS[1], MSSDIO, SSPSCLK, SSPSCLK2, SSPSCLK3, SSPSFRM, SSPSFRM2, SSPSFRM3, LDD[17:0], CIF\_LV, CIF\_FV, and the I<sup>2</sup>C pins PWR\_SDA, PWR\_SCL, SDA and SCL are special bidirectional GPIOs. The direction of the pin is controlled by the peripheral directly overriding the GPIO direction settings for these pins (GPDR).

Note that the alternate function for input and output variants of these functions is the same. For example, configuring GPIO[112] with the alternate function 01 selects MMCMD in both input and output mode.

## ConnectCore XP 270 GPIO use

This table shows GPIO use in both the XScale PXA270 and ConnectCore XP 270 modules. The shaded entries have explanatory comments following the table.

XScale PXA270						ConnectCore XP 270				
PBGA ball#	GPIO #	Prim Func	Sec Func	Third Func	Reset	Name Selec	Type	Alt Func	Level	Interr
U20	0	GPIO0	/	/	GPIO/PD	GPIO0	INP	AF0	HIGH	R_EDGE
U21	1	GPIO1	/	/	GPIO/PU	GPIO1	INP	AF0	HIGH	R_EDGE
V21	/	SYS_EN	/	/	SYS_EN	SYS_EN	Undef	Undef	Undef	Undef
V22	3	PWR_SCL	/	/	GPIO/PU	PWR_SCL	INP	AF1	HIGH	NO_EDGE
T19	4	PWR_SDA	/	/	GPIO/PU	PWR_SDA	INP	AF1	HIGH	NO_EDGE
Y19	5	PWR_CAP0	/	/	/	PWR_CAP0	Undef	Undef	Undef	Undef
AA21	/	PWR_CAP1	/	/	/	PWR_CAP1	Undef	Undef	Undef	Undef
Y18	/	PWR_CAP2	/	/	/	PWR_CAP2	Undef	Undef	Undef	Undef
W17	/	PWR_CAP3	/	/	/	PWR_CAP3	Undef	Undef	Undef	Undef

XScale PXA270						ConnectCore XP 270				
T22	9	/	/	FFCTS	GPIO/ PD	NC	OUT	AF0	HIGH	NO_EDGE
		HZ_CLK		CHOUT0						
U22	10	FFDVD	/	USB_P3_5	GPIO/ PD	GPIO10	INP	AF0	HIGH	NO_EDGE
		HZ_CLK		CHOUT1						
A8	11	EXT_SYNC0	SSPRXD2	USB_P3_1	GPIO/ PD	NC	OUT	AF0	HIGH	NO_EDGE
		CHOUT0	PWM_OUT2	48_MHz						
A7	12	EXT_SYNC1	CIF_DD7	/	GPIO/ PD	NC	OUT	AF0	HIGH	NO_EDGE
		CHOUT1	PWM_OUT3	48_MHz						
A6	13	CLK_EXT	KP_DKIN7	KP_MKIN7	GPIO/ PD	NC	OUT	AF0	HIGH	NO_EDGE
		SSPTXD2	/	/						
P20	14	L_VSYNC	SSPSFRM2	/	GPIO/ PD	NC	OUT	AF0	HIGH	NO_EDGE
		/	SSPSFRM2	UCLK						
A4	15	/	/	/	GPIO/ PD	CS1#	OUT	AF2	HIGH	NO_EDGE
		PCE1#	CS1#	/						
C14	16	KP_MKIN5	/	/	GPIO/ PD	PWM0 /GPIO16	OUT	AF2	LOW	NO_EDGE
		/	PWM_OUT0	FFTXD						
D15	17	KP_MKIN6	CIF_DD6	/	GPIO/ PD	PWM1 /GPIO17	OUT	AF2	LOW	NO_EDGE
		/	PWM_OUT1	/						
D9	18	RDY	/	/	GPIO/ PD	RDY/GPIO18	INP	AF1	HIGH	NO_EDGE
		/	/	/						
P19	19	SSPCLK2	/	FFRXD	GPIO/ PD	NC	OUT	AF0	HIGH	NO_EDGE
		SSPCLK2	L_CS	URST#						
W5	20	DREQ0	MBREQ	/	GPIO/ PU	SDCS2#	OUT	AF1	HIGH	NO_EDGE
		SDCS2#	/	/						
Y6	21	/	/	/	GPIO/ PU	SDCS3#	OUT	AF1	HIGH	NO_EDGE
		SDCS3#	DVAL0	MBGNT						
A12	22	SSPEXTCLK2	SSPSCLKEN2	SSPCLK2	GPIO/ PD	NC	OUT	AF0	HIGH	NO_EDGE
		KP_MKOUT7	SSPSYCLK2	SSPCLK2						
A16	23	/	SSPCLK	/	GPIO/ PD	SSP_SCLK / GPIO23	INP	AF2	HIGH	NO_EDGE
		CIF_MCLK	SSPCLK	/						

XScale PXA270						ConnectCore XP 270				
B14	24	CIF_FV	SSPSFRM	/	GPIO/ PD	SSP_SFRM / GPIO24	INP	AF2	HIGH	NO_EDGE
		CIF_FV	SSPSFRM	/						
A15	25	CIF_LV	/	/	GPIO/ PD	SSP_TXD / GPIO25	OUT	AF2	HIGH	NO_EDGE
		CIF_LV	SSPTXD	/						
A14	26	SSPRXD	CIF_PCLK	FFCTS	GPIO/ PD	SSP_RXD / GPIO26	INP	AF1	HIGH	NO_EDGE
		/	/	/						
C13	27	SSPEXTCLK	SSPSCLKEN	CIF_DD0	GPIO/ PD	NC	OUT	AF0	HIGH	NO_EDGE
		SSPSYSCLK	/	FFRTS						
D12	28	AC97_BIT CLK	I2S_BITCLK	SSPSFRM	GPIO/ PD	AC97_BITCLK/ GPIO28	INP	AF1	HIGH	NO_EDGE
		I2S_BITCLK	/	SSPSFRM						
A11	29	AC97_ SDATA_IN_0	I2S_SDATA_ IN	SSPSCLK	GPIO/ PD	AC97_SDATA_ IN0 / GPIO29	INP	AF1	HIGH	NO_EDGE
		SSPRXD2	/	SSPSCLK						
B11	30	/	/	/	GPIO/ PD	AC97_SDATA_ OUT / GPIO30	OUT	AF2	HIGH	NO_EDGE
		I2S_SDATA_ OUT	AC97_ SDATA_OUT	USB_P3_2						
C11	31	/	/	/	GPIO/ PD	AC97_SYNC / GPIO31	OUT	AF2	HIGH	NO_EDGE
		I2S_SYNC	AC97_SYNC	USB_P3_6						
C16	32	/	/	/	GPIO/ PD	PSKTSEL / GPIO104 / MM_CLK	INP	AF0	HIGH	NO_EDGE
		MSSCLK	MMCLK	/						
C7	33	FFRXD	FFDSR	/	GPIO/ PU	CS5#	OUT	AF2	HIGH	NO_EDGE
		DVAL<1>	CS5#	MBGNT						
B19	34	FFRXD	KP_MKIN3	SSPSCLK3	GPIO/ PD	GPIO34	INP	AF0	HIGH	NO_EDGE
		USB_P2_2	/	SSPSCLK3						
D17	35	FFCTS	USB_P2_1	SSPSFRM3	GPIO/ PD	FF_CTS# / GPIO35	INP	AF1	HIGH	NO_EDGE
		/	KP_MKOUT6	SSPTXD3						
B13	36	FFDCD	SSPSCLK2	KP_MKIN7	GPIO/ PD	FF_DCD# / GPIO36	INP	AF1	HIGH	NO_EDGE
		USB_P2_4	SSPSCLK2	/						
D13	37	FFDSR	SSPSFRM2	KP_MKIN3	GPIO/ PD	FFDSR# / GPIO37	INP	AF1	HIGH	NO_EDGE
		USB_P2_8	SSPSFRM2	FFTXD						

XScale PXA270						ConnectCore XP 270				
A13	38	FFRI	KP_MKIN4	USB_P2_3	GPIO/ PD	FF_RI# / GPIO38	INP	AF1	HIGH	NO_EDGE
		SSPTXD3	SSPTXD2	PWM_OUT1						
B17	39	KP_MKIN4	/	SSPSFRM3	GPIO/ PD	FF_TXD / GPIO39	OUT	AF2	HIGH	NO_EDGE
		USB_P2_6	FFTXD	SSPSFRM3						
C12	40	SSPRXD2	/	USB_P2_5	GPIO/ PD	FF_DTR# / GPIO40	OUT	AF2	HIGH	NO_EDGE
		KP_MKOUT6	FFDTR	SSPSCLK3						
A19	41	FFRXD	USB_P2_7	SSPRXD3	GPIO/ PD	FF_RTS# / GPIO41	OUT	AF2	HIGH	NO_EDGE
		KP_MKOUT7	FFRTS	/						
D20	42	BTRXD	ICP_RXD	/	GPIO/ PD	BT_RXD / GPIO42	INP	AF1	HIGH	NO_EDGE
		/	/	CIF_MCLK						
B21	43	/	/	CIF_FV	GPIO/ PD	BT_TXD / GPIO43	OUT	AF2	HIGH	NO_EDGE
		ICP_TXD	BTTXD	CIF_FV						
A20	44	BTCTS	/	CIF_LV	GPIO/ PD	BT_CTS# / GPIO44	INP	AF1	HIGH	NO_EDGE
		/	/	CIF_LV						
C17	45	/	/	CIF_PCLK	GPIO/ PD	BT_RTS#/ GPIO45	OUT	AF2	HIGH	NO_EDGE
		AC97_SYS CLK	BTRTS	SSPSYSCLK3						
A9	46	ICP_RXD	STD_RXD	/	GPIO/ PD	IR_RXD / GPIO46	INP	AF1	HIGH	NO_EDGE
		/	PWM_OUT2	/						
C10	47	CIF_DD0	/	/	GPIO/ PD	IR_TXD / GPIO47	OUT	AF2	HIGH	NO_EDGE
		STD_TXD	ICP_TXD	PWM_OUT3						
Y11	48	CIF_DD5	/	/	GPIO/ PU	POE# / GPIO48	OUT	AF2	HIGH	NO_EDGE
		BB_OB_DAT1	POE#	/						
D10	49	/	/	/	GPIO/ PU	PWE# / GPIO49	OUT	AF2	HIGH	NO_EDGE
		/	PWE#	/						
W12	50	CIF_DD3	/	SSPSCLK2	GPIO/ PU	PIOR# / GPIO50	OUT	AF2	HIGH	NO_EDGE
		BB_OB_DAT2	PIOIR#	SSPSCLK2						
AB12	51	CIF_DD2	/	/	GPIO/ PU	PIOW# / GPIO51 / MM_DAT0	OUT	AF2	HIGH	NO_EDGE
		BB_OB_DAT3	PIOIW#	/						

XScale PXA270						ConnectCore XP 270				
Y12	52	CIF_DD4	SSPSCLK3	/	GPIO/ PD	NC	OUT	AF0	HIGH	NO_EDGE
		BB_OB_CLK	SSPSCLK3	/						
AA12	53	FFRXD	USB_P2_3	/	GPIO/ PD	FF_RXD / GPIO53	INP	AF1	HIGH	NO_EDGE
		BB_OB_STB	CIF_MCLK	SSPSYSCLK						
AB13	54	/	BB_OB_WAIT	CIF_PCLK	GPIO/ PD	PCE2# / GPIO54	OUT	AF2	HIGH	NO_EDGE
		/	PCE2#	/						
W9	55	CIF_DD1	BB_IB_DAT1	/	GPIO/ PU	PREG# / GPIO55 / MM_DAT1	OUT	AF2	HIGH	NO_EDGE
		/	PREG#	/						
AB8	56	PWAIT#	BB_IB_DAT2	/	GPIO/ PU	PWAIT# / GPIO56 / MM_DAT2	INP	AF1	HIGH	NO_EDGE
		USB_P3_4	/	/						
AB9	57	IOIS16#	BB_IB_DAT3	/	GPIO/ PU	PIOS16# / GPIO57 / MM_DAT3	INP	AF1	HIGH	NO_EDGE
		/	/	SSPTXD						
G20	58	/	LDD0	/	GPIO/ PD	LDD0 / GPIO58	OUT	AF2	HIGH	NO_EDGE
		/	LDD0	/						
H20	59	/	LDD1	/	GPIO/ PD	LDD1 / GPIO59	OUT	AF2	HIGH	NO_EDGE
		/	LDD1	/						
G21	60	/	LDD2	/	GPIO/ PD	LDD2 / GPIO60	OUT	AF2	HIGH	NO_EDGE
		/	LDD2	/						
F22	61	/	LDD3	/	GPIO/ PD	LDD3 / GPIO61	OUT	AF2	HIGH	NO_EDGE
		/	LDD3	/						
G22	62	/	LDD4	/	GPIO/ PD	LDD4 / GPIO62	OUT	AF2	HIGH	NO_EDGE
		/	LDD4	/						
J20	63	/	LDD5	/	GPIO/ PD	LDD5 / GPIO63	OUT	AF2	HIGH	NO_EDGE
		/	LDD5	/						
H22	64	/	LDD6	/	GPIO/ PD	LDD6 / GPIO64	OUT	AF2	HIGH	NO_EDGE
		/	LDD6	/						
K20	65	/	LDD7	/	GPIO/ PD	LDD7 / GPIO65	OUT	AF2	HIGH	NO_EDGE
		/	LDD7	/						
J19	66	/	LDD8	/	GPIO / PD	LDD8 / GPIO66	OUT	AF2	HIGH	NO_EDGE
		/	LDD8	/						

XScale PXA270						ConnectCore XP 270				
K19	67	/	LDD9	/	GPIO/ PD	LDD9 / GPIO67	OUT	AF2	HIGH	NO_EDGE
		/	LDD9	/						
K21	68	/	LDD10	/	GPIO/ PD	LDD10 / GPIO68	OUT	AF2	HIGH	NO_EDGE
		/	LDD10	/						
J22	69	/	LDD11	/	GPIO/ PD	LDD11 / GPIO69	OUT	AF2	HIGH	NO_EDGE
		/	LDD11	/						
K22	70	/	LDD12	/	GPIO/ PD	LDD12 / GPIO70	OUT	AF2	HIGH	NO_EDGE
		/	LDD12	/						
L20	71	/	LDD13	/	GPIO/ PD	LDD13 / GPIO71	OUT	AF2	HIGH	NO_EDGE
		/	LDD13	/						
L21	72	/	LDD14	/	GPIO/ PD	LDD14 / GPIO72	OUT	AF2	HIGH	NO_EDGE
		/	LDD14	/						
L22	73	/	LDD15	/	GPIO/ PD	LDD15 / GPIO73	OUT	AF2	HIGH	NO_EDGE
		/	LDD15	/						
N22	74	/	/	/	GPIO/ PD	FCLK / GPIO73	OUT	AF2	HIGH	NO_EDGE
		/	L_FCLK_RD	/						
N20	75	/	/	/	GPIO/ PD	LCLK / GPIO75	OUT	AF2	HIGH	NO_EDGE
		/	L_LCLK_A0	/						
N21	76	/	/	/	GPIO/ PD	PCLK / GPIO76	OUT	AF2	HIGH	NO_EDGE
		/	L_PCLK_WR	/						
P21	77	/	/	/	GPIO/ PD	LBIAS / GPIO77	OUT	AF2	HIGH	NO_EDGE
		/	L_BIAS	/						
D8	78	/	/	/	GPIO/ PU	CS2#	OUT	AF2	HIGH	NO_EDGE
		PCE2#	CS2#	/						
A5	79	/	/	/	GPIO/ PU	CS3#	OUT	AF2	HIGH	NO_EDGE
		PSKTSEL	CS3#	PWM_OUT2						
D7	80	DREQ1	MBREQ	/	GPIO/ PU	CS4#	OUT	AF2	HIGH	NO_EDGE
		/	CS4#	PWM_OUT3						
W10	81	/	CIF_DD0	/	GPIO/ PU	NSSP_TXD / GPIO81	OUT	AF1	HIGH	NO_EDGE
		SSPTXD3	BB_OB_DAT0	/						

XScale PXA270						ConnectCore XP 270				
AA8	82	SSPRXD3 /	BB_IB_DAT0 /	CIF_DD5 FFDTR	GPIO/ PU	NSSP_RXD/ GPIO82	INP	AF1	HIGH	NO_EDGE
AB10	83	SSPSFRM3 SSPSFRM3	BB_IB_CLK FFTXD	CIF_DD4 FFRTS	GPIO/ PD	NSSP_FRM/ GPIO83	INP	AF1	HIGH	NO_EDGE
Y10	84	SSPCLK3 SSPCLK3	BB_IB_STB /	CIF_FV CIF_FV	GPIO/ PD	NSSP_CLK/ GPIO84	INP	AF1	HIGH	NO_EDGE
AA0	85	FFRXD PCE1#	DREQ2 BB_IB_WAIT	CIF_LV CIF_LV	GPIO/ PD	PCE1# / GPIO85	OUT	AF1	HIGH	NO_EDGE
M20	86	SSPRXD2 PCE1#	LDD16 LDD16	USB_P3_5 /	GPIO/ PD	NC	OUT	AF0	HIGH	NO_EDGE
M22	87	PCE2# SSPTXD2	LDD17 LDD17	SSPSFRM2 SSPSFRM2	GPIO/ PD	ONE_WIRE_ EEPROM	OUT	AF0	HIGH	NO_EDGE
C22	88	USBHPWR1 /	SSPRXD2 /	SSPSFRM2 SSPSFRM2	GPIO/ PD	NC	OUT	AF0	HIGH	NO_EDGE
C21	89	SSPRXD3 AC97_SYS CLK	/ USBHPEN1	FFRI SSPTXD2	GPIO/ ND	NC	OUT	AF0	HIGH	NO_EDGE
H19	90	KP_MKIN5 /	USB_P3_5 URST#	CIF_DD4 /	GPIO/ PD	ETHERNET_ INT	INP	AF0	HIGH	R_EDGE
G19	91	KP_MKIN6 /	USB_P3_1 UCLK	CIF_DD5 /	GPIO/ PD	NC	OUT	AF0	HIGH	NO_EDGE
A18	92	MMDAT0 MMDAT0	/ MSBS	/ /	GPIO/ PD	PIOW#/ GPIO51 / MM_DAT0	INP	AF0	HIGH	NO_EDGE
Y16	93	KP_DKIN0 AC97_ SDATA_OUT	CIF_DD6 /	/ /	GPIO/ PD	NC	OUT	AF0	HIGH	NO_EDGE
AA17	94	KP_DKIN1 AC97_SYNC	CIF_DD5 /	/ /	GPIO/ PD	NC	OUT	AF0	HIGH	NO_EDGE
AB18	95	KP_DKIN2 AC97_ RESET#	CIF_DD4 /	KP_MKIN6 /	GPIO/ PD	NC	OUT	AF0	HIGH	NO_EDGE

XScale PXA270						ConnectCore XP 270				
W16	96	KP_DKIN3	MBREQ	FFRXD	GPIO/ PD	NC	OUT	AF0	HIGH	NO_EDGE
		/	DVAL1	KP_MKOUT6						
Y15	97	KP_DKIN4	DREQ1	KP_MKIN3	GPIO/ PD	DREQ1 / GPIO97	INP	AF2	HIGH	NO_EDGE
		/	MBGNT	/						
AA16	98	KP_DKIN5	CIF_DD0	KP_MKIN4	GPIO/ PD	NC	OUT	AF0	HIGH	NO_EDGE
		AC97_ SYSCLK	/	FFRTS						
AB17	99	KP_DKIN6	AC97_ SDATA_IN1	KP_MKIN5	GPIO/ PD	AC97_SDATA_ IN1 / GPIO99	INP	AF2	HIGH	NO_EDGE
		/	/	FFTXD						
AA15	100	KP_MKIN0	DREQ2	FFCTS	GPIO/ PD	NC	OUT	AF0	HIGH	NO_EDGE
		/	/	/						
AB16	101	KP_MKIN1	/	/	GPIO/ PD	NC	OUT	AF0	HIGH	NO_EDGE
		/	/	/						
Y14	102	KP_MKIN2	/	FFRXD	GPIO/ PD	NC	OUT	AF0	HIGH	NO_EDGE
		PCE1#	/	/						
AB15	103	CIF_DD3	/	/	GPIO/ PD	NC	OUT	AF0	HIGH	NO_EDGE
		/	KP_MKOUT0	/						
W14	104	CIF_DD2	/	/	GPIO/ PD	PSKTSEL / GPIO104 / MM_CLK	OUT	AF1	HIGH	NO_EDGE
		PSKTSEL	KP_MKOUT1	/						
Y13	105	CIF_DD1	/	/	GPIO/ PD	NC	OUT	AF0	HIGH	NO_EDGE
		PCE2#	KP_MKOUT2	/						
W13	106	CIF_DD9	/	/	GPIO/ PD	GPIO106 / SDCKE0#	OUT	AF0	HIGH	NO_EDGE
		/	KP_MKOUT3	/						
AB14	107	CIF_DD8	/	/	GPIO/ PD	NC	OUT	AF0	HIGH	NO_EDGE
		/	KP_MKOUT4	/						
AA13	108	CIF_DD7	/	/	GPIO/ PD	NC	OUT	AF0	HIGH	NO_EDGE
		CHOUT0	KP_MKOUT5	/						
D16	109	MMDAT1	MSSDIO	/	GPIO/ PD	PREG# / GPIO55 / MM_DAT1	INP	AF0	HIGH	NO_EDGE
		MMDAT1	MSSDIO	/						

XScale PXA270						ConnectCore XP 270					
C15	110	MMDAT2 / MMCCS0	/	/	GPIO/ PD	PWAIT# / GPIO56 / MM_DAT2	INP	AF0	HIGH	NO_EDGE	
		MMDAT2 / MMCCS0	/	/							
A17	111	MMDAT3 / MMCCS1	/	/	GPIO/ PD	PIOS16# / GPIO57 / MM_DAT3	INP	AF0	HIGH	NO_EDGE	
		MMDAT3 / MMCCS1	/	/							
B16	112	MMCMD	MSINS#	/	GPIO/ PD	PIOR# / GPIO50 / MM_CMD	INP	AF0	HIGH	NO_EDGE	
		MMCMD	/	/							
A10	113	/	/	USB_P3_3	GPIO/ PD	AC97_RESET#/ GPIO113	OUT	AF2	HIGH	NO_EDGE	
		I2S_SYSCLK	AC97 RESET#	/							
F19	114	CIF_DD1	/	/	GPIO/ PD	NC	OUT	AF0	HIGH	NO_EDGE	
		/	UVS0	/							
E21	115	DREQ0	CIF_DD3	MBREQ	GPIO/ PU	DREQ0 / GPIO115	INP	AF1	HIGH	NO_EDGE	
		UEN	UVS1#	PWM_OUT1							
E20	116	CIF_DD2	AC97_ SDATA_IN_0	UDET	GPIO/ PU	NC	OUT	AF0	HIGH	NO_EDGE	
		DVAL0	UVS2#	MBGNT							
C18	117	SCL	/	/	GPIO/ PU	SCL / GPIO117	INP	AF1	HIGH	NO_EDGE	
		SCL	/	/							
B20	118	SDA	/	/	GPIO/ PU	SDA / GPIO118	INP	AF1	HIGH	NO_EDGE	
		SDA	/	/							
	119	NOT AVAILABLE ON PXA270				NOT AVAILABLE ON PXA270					
	120	NOT AVAILABLE ON PXA270				NOT AVAILABLE ON PXA270					

### Comments

- PBGA ball V21: SYS\_EN cannot be used as a GPIO.
- PBGA ball Y19: PWR\_CAP0 cannot be used as a GPIO.
- PBGA ball AA21: PWR\_CAP1 cannot be used as a GPIO.
- PBGA ball Y18: PWR\_CAP2 cannot be used as a GPIO.
- PBGA ball W17: PWR\_CAP3 cannot be used as a GPIO.

**Notes**

- Although the level field doesn't affect an input signal, the level field is on a high level in case the pin is changed to an output.
- Although the interrupt field doesn't affect an output signal, the interrupt field is on a NO\_EDGE level in case the pin is changed to an input.
- SYS\_EN and PWR\_CAP<x> are not real GPIO signals (shaded signals). Their type, level, and interrupt trigger, therefore, cannot be chosen as for any other GPIO.
- As explained in the Intel PXA270 developer manual, all unused GPIOs have been configured as outputs to minimize power consumption.

**GPIO Controller Register Summary**

This table shows the standard register values for the ConnectCore XP 270 module.

Register Name	Register Address	Register Value
GPDR0	0x40E0 000C	0xCA7B FA00
GPDR1	0x40E0 0010	0xFCDF AB82
GPDR2	0x40E0 0 014	0xEBE3 FFFF
GPDR3	0x40E0 010C	0x0016 1FF5
GPSR0	0x40E0 0018	0xFFFC FE1B
GPSR1	0x40E0 001C	0xFFFF FFFF
GPSR2	0x40E00 020	0xFFFF FFFF
GPSR3	0x40E0 0118	0x007F FFFF
GPCR0	0x40E0 0024	0x0003 0000
GPCR1	0x40E0 0028	0x0000 0000
GPCR2	0x40E0 002C	0x0000 0000
GPCR3	0x40E0 0124	0x0000 0000
GRER0	0x40E0 0030	0x0000 0003
GRER1	0x40E0 0034	0x0000 0000
GRER2	0x40E0 0038	0x0400 0000

Register Name	Register Address	Register Value
GRER3	0x40E0 0130	0x0000 0000
GFER0	0x40E0 003C	0x0000 0000
GFER1	0x40E0 0040	0x0000 0000
GFER2	0x40E0 0044	0x0000 0000
GFER3	0x40E0 013C	0x0000 0000
GAFR0_L	0x40E0 0054	0x8000 0140
GAFR0_U	0x40E0 0058	0xA51A 851A
GAFR1_L	0x40E0 005C	0x999A 9548
GAFR1_U	0x40E0 0060	0xAAA5 A4AA
GAFR2_L	0x40E0 0064	0xAAAA AAAA
GAFR2_U	0x40E00068	0x0000 0556
GAFR3_L	0x40E0 006C	0x0001 0088
GAFR3_U	0x40E0 0070	0x0000 1448

## GPIOs used internally

GPIO	Direction	Description
GPIO3	Output	PWR_SCL signal used for controlling the Power Management IC
GPIO4	I/O	PWR_SDA signal used for controlling the Power Management IC
GPIO87	I/O	One-Wire-EEPROM
GPIO90	Input	Ethernet Controller interrupt signal

## ConnectCore XP 270 Memory Map

The ConnectCore XP 270 memory map is shown next.

0xE000_0000	Reserved (512 Mbyte)	
0xC000_0000	Reserved (512 Mbyte)	
0xB000_0000	SDRAM partition 1 (256 Mbyte)	NOT AVAILABLE ON ConnectCore XP 270 MODULE
0xA000_0000	SDRAM partition 0 (256 Mbyte)	SDRAM memory area
0x9000_0000	SDRAM partition 3 (256 Mbyte)	NOT AVAILABLE ON ConnectCore XP 270 MODULE
0x8000_0000	SDRAM partition 2 (256 Mbyte)	NOT AVAILABLE ON ConnectCore XP 270 MODULE
0x6000_0000	Reserved (512 Mbyte)	
0x5C00_0000	Internal memory storage	
0x5800_0000	Internal Memory Control registers	
0x5400_0000	Reserved (64 Mbyte)	
0x5000_0000	Capture Interface Control registers	NOT AVAILABLE ON ConnectCore XP 270 MODULE
0x4C00_0000	USB Host Control registers	
0x4800_0000	Memory Controller Control registers	
0x4400_0000	LCD Control registers	
0x4000_0000	Peripherals memory-mapped registers (see the PXA270 developer guide)	
0x3000_0000	PC card / CompactFlash Slot 1 (256 Mbyte)	
0x2000_0000	PC Card / CompactFlash Slot 0 (256 Mbyte)	
0x1C00_0000	Reserved (64 Mbyte)	

0x1800_0000	Reserved (64 Mbyte)	
0x1400_0000	CS5# (64 Mbyte)	Free for external use
0x1000_0000	CS4# (64 Mbyte)	Free for external use
0x0C00_0000	CS3# (64 Mbyte)	Free for external use
0x800_0000	CS2# (64 Mbyte)	Free for external use
0x400_0000	CS1# (64 Mbyte)	0x0400_0310-0x07FF_FFFF Reserved SMSC LAN91C111 0x400_0300-0x0400_030F SMSC LAN91C111 0x0400_0000-0x0400_02FF reserved SMSC LAN91C111
0x0000_0000	CS0# (64 Mbyte)	Flash memory area



---

# *About the Development Board*

---

## C H A P T E R 2

**T**his chapter provides information for configuring the ConnectCore XP 270 development board.

## XScale

---

Intel XScale is a 32-bit RISC microarchitecture based on architecture by Advanced RISC Machines (ARM), now the most popular 32-bit embedded CPU family in the world. ARM-based and Intel XScale technology are completely binary compatible, so software and software-developed tools designed for older ARM processors also work on newer Intel XScale core-based processors.

The Intel XScale RISC microarchitecture is noted for its efficiency. It obtains high performance, minimal number of silicon transistors, which require less power to operate the chip. It also means the chip processor itself will take up less silicon, making it smaller and less expensive to manufacture in volume. This combination of high performance, small size, low power, and modest cost gives the Intel PXA270 applications processor some compelling advantages over competing processors.

The Intel XScale core in the Intel PXA270 applications processor is a generational improvement over the previous Intel® StrongARM\* processors, the Intel® SA-1100 and the Intel® SA-1110. Unlike the SA chips, the Intel PXA270 applications processor includes the ARM® Thumb® code-compression technology. The Thumb technology compresses software density by about 30 percent over normal RISC code. This compression (and the corresponding real-time decompression) is handled automatically by the Intel PXA270 applications processor; engineers and programmers are generally unaware of its operation. They only notice the improved memory utilization.

Another improvement in the Intel XScale core is the dual-multiply/accumulate (dual-MAC) instruction. A MAC operation is a relatively new addition to most computers and microprocessors, borrowed from the Digital Signal Processor (DSP) world. MAC operations are so vital to many audio, video, and wireless applications, that one or two MAC instructions can dramatically benefit a chip's ability to run these multimedia applications.

The improved processor technology additionally supports a new Turbo Mode clocking technique. Turbo Mode allows the user to clock the processor core at a higher frequency during peak processing requirements. It allows a synchronous switch in frequencies without disrupting the Memory Controller, LCD Controller, or any peripheral.

The Intel PXA270 processor uses a new Micro-Power-Management that results in less than 50% power consumption, compared to a StrongARM SA-1110 processor running on the same clock speed.

## What's on the development board?

---

The ConnectCore XP 270 development board integrates all components that are necessary to operate the ConnectCore XP 270 module.

These are development board features. A picture of the development board, with the locations of connectors, sockets, and other components, follows the feature list.

- 200-pin ConnectCore XP 270 socket
- Compact Flash card socket, selectable true IDE or CF mode
- RS232 interface and connector
- JTAG interface
- All pins of the ConnectCore XP 270 socket are connected flat cable headers
- Predecoded chip select signals
- Buffered address and data bus
- USB Device connector
- USB Host controller and connector
- 40-pin universal LCD flat cable header
- Daughter board slot for easy application design-in
- Ethernet magnetics and connector for ConnectCore XP 270 onboard Ethernet controllers
- Disconnectable ConnectCore XP 270 power supply for power consumption measurements
- 3.3V single supply design; 5V also available onboard
- Single power supply: 12VDC

## *The development board*

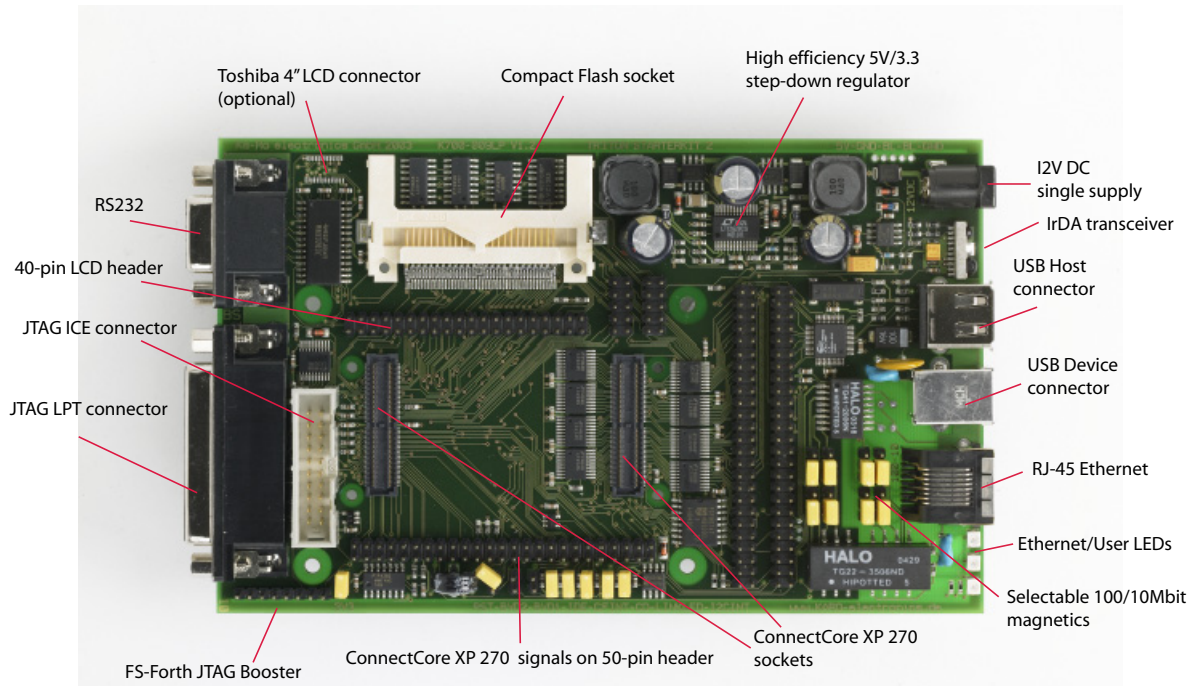

## **General Precautions**

Review these general precautions before you begin working with the development board.

- Unplug the power cord from the wall socket before touching any component.
- Use a grounded wrist strap or touch a safely grounded object, such as the metal power supply case or the heating, before handling components to avoid damaging them due to static electricity.
- Hold components by the edges and do not touch the ICs on them.
- Whenever you uninstall any component, place it on a grounded antistatic pad or in the bag that came with the component.

## Installation

---

There are two steps involved with installing the ConnectCore XP 270:

- 1 Replacing the module
- 2 Setting up basic and optional connections

### Replacing the module

The ConnectCore XP 270 processor module is plugged onto the socket of the development board.

- 1 To remove the module, lift it carefully and do not tilt it too much!
- 2 Place the module at the correct position.

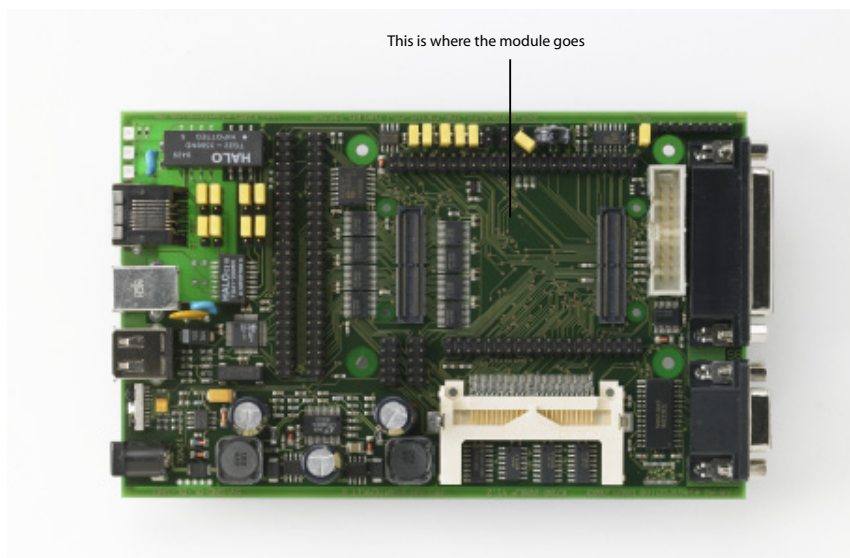

- 3 You will feel a slight lock into the sockets. The four mounting holes can also be used for visual alignment.

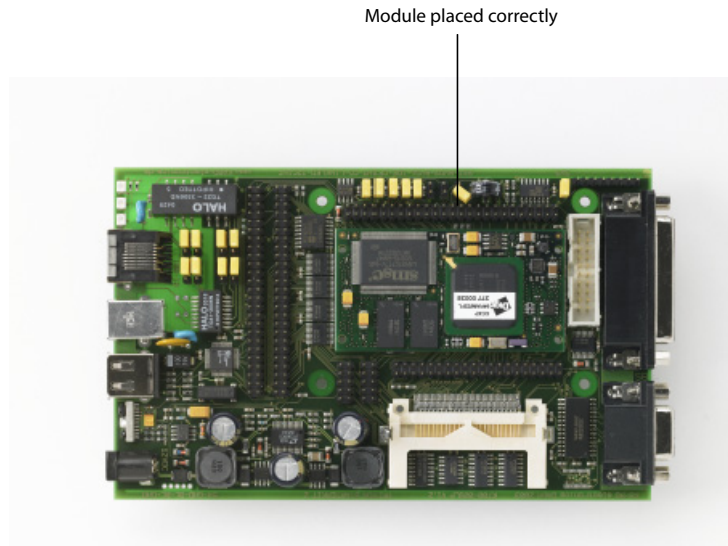

**Do not press in the middle of the module and do not bend the boards!**

## Setting up basic and optional connections

Basic connections	
Power supply	A wall power supply is included in the development board package. The secondary voltage should be set to 12V.
Terminal connection	Use the supplied DB-9 cable to connect the RS232 port to a communication port of your host PC; for example, COM1. You need a terminal program, such as Windows HyperTerminal or Unix based minicom or cu, running on your host PC. The default communication parameters are 38400 baud, 8 data bits, no parity, one stop bit(38400 8N1) and Xon/Xoff handshake. Be sure to <i>disable</i> the hardware handshake (RTS/CTS).
Optional connections	
Ethernet	The development board can be integrated into your local network. For the ConnectCore XP 270, you need these connections: <ul style="list-style-type: none"> <li>■ Set 8 jumpers to 100Mbit/s magnetics</li> <li>■ Use a straight patch cable to connect the development board to a hub or switch</li> </ul>
JTAG	JTAG is used primarily for firmware updates. If necessary, use the JTAG Booster tool provided to connect the JTAG 20-pin Multi-Ice connector (ST10) with the parallel port of your host PC. <b>Be aware:</b> This connection can set the development board into reset state until the firmware update program has been started. Leave this port unconnected if not used.
USB	Two USB connectors are provided on the development board. The USB-Host connector ST7 can be used for devices such as keyboard or mouse. The development board can also act as a USB device when connected to a PC. In this case, the USB Device connector ST8 must be used.

# Hardware block diagram

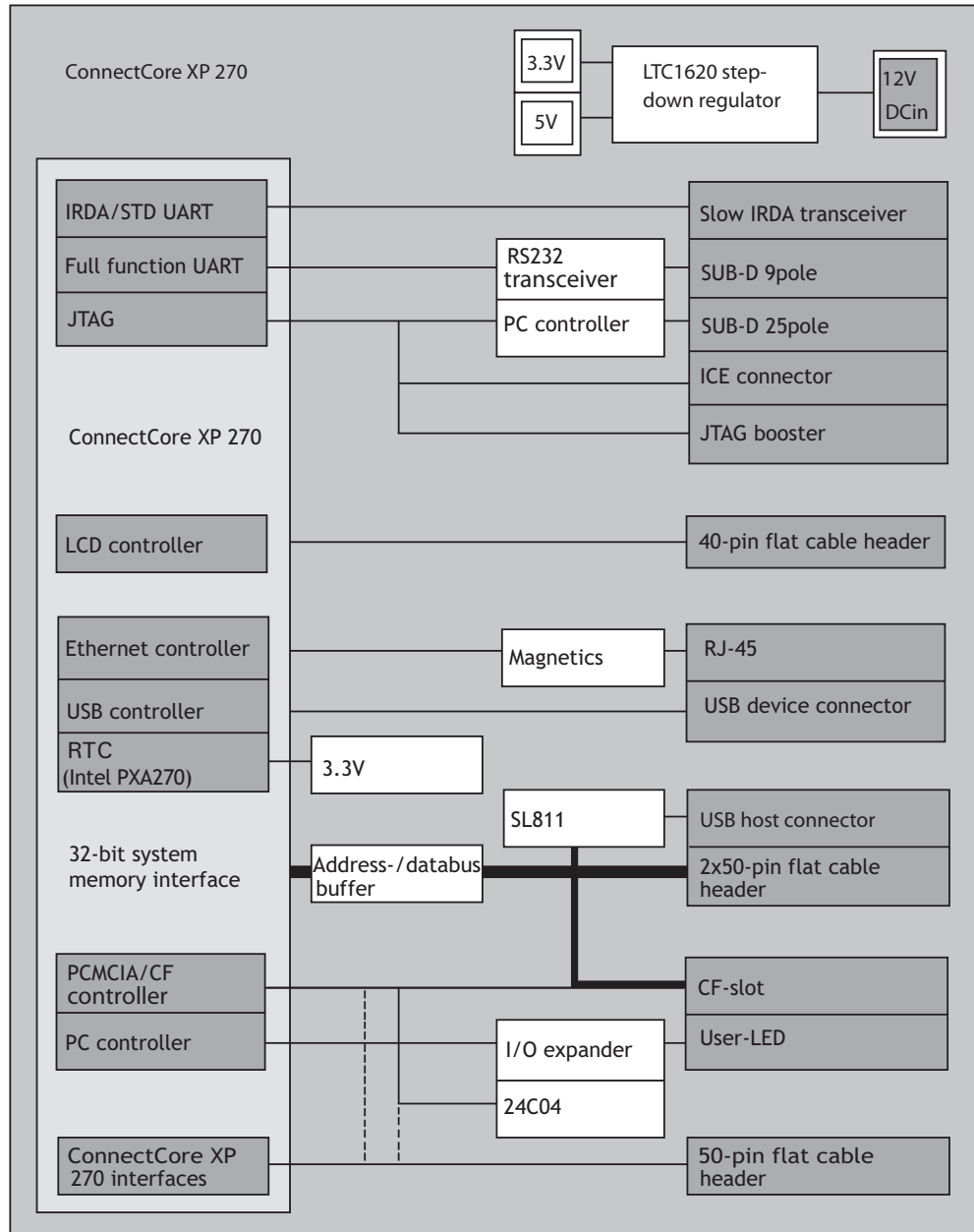

## LEDs and selection of Ethernet magnetics

These two drawings show the user LED, the positions of the magnetics jumpers, and Ethernet connections:

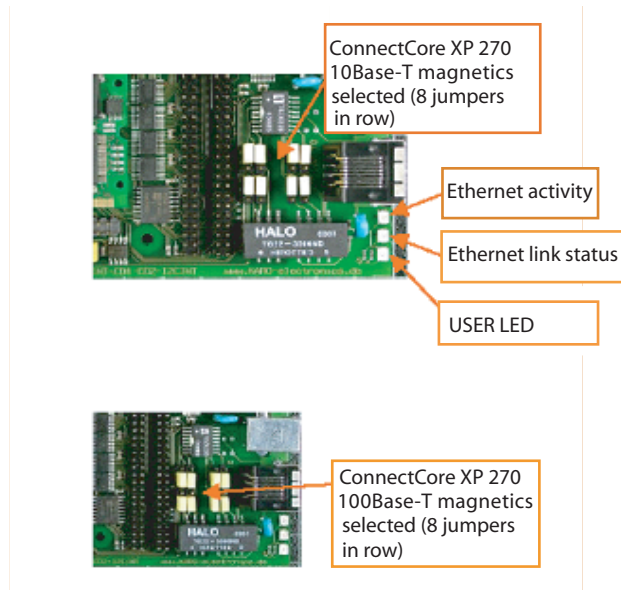

## Jumpers

The ConnectCore XP 270 jumpers are listed next. Factory settings are typed in boldface.

3V3	<b>ConnectCore XP 270 power supply</b>	
	<b>closed</b>	Only to measure ConnectCore XP 270 current consumption! Never leave this jumper open while power is connected!
RST	<b>System reset</b>	
	<b>open</b>	Normal operation
	<b>closed</b>	System reset

<b>BVD2</b>	<b>Compact-Flash BVD2/SPKR/DASP (leave jumper LINKLED open if closed)</b>
<b>open</b>	GPIO33 (pin 114) free for use
<b>closed</b>	Compact-Flash BVD2 routed to GPIO33 (pin 114)
<b>BVD1</b>	<b>Compact-Flash BVD1/STSCHG/PDIAG (leave jumper CD open if closed)</b>
<b>open</b>	GPIO80 (pin 115) free for use
<b>closed</b>	Compact-Flash BVD1 routed to GPIO80 (pin 115)
<b>IDE</b>	<b>Compact-Flash operation mode</b>
<b>open</b>	Compact-Flash mode
<b>closed</b>	True IDE mode
<b>CFINT</b>	<b>Compact-Flash interrupt</b>
<b>open</b>	GPIO10 (pin 53) free for use
<b>closed</b>	Compact-Flash interrupt routed to GPIO10 (pin 53)
<b>CD</b>	<b>Compact-Flash Card_Detect (leave jumper BVD1 open if closed)</b>
<b>open</b>	GPIO80 (pin 115) free for use
<b>closed</b>	Compact-Flash CD1 ored with CD2 routed to GPIO80 (pin 115)
<b>LINKLED</b>	<b>Ethernet Link LED (leave jumper BVD2 open if closed)</b>
<b>open</b>	GPIO33 (pin 114) free for use
<b>closed</b>	Ethernet Link LED routed to GPIO33 (pin 114) to realize wake on LAN functionality
<b>I2CINT</b>	<b>I<sup>2</sup>C Controller interrupt</b>
<b>open</b>	GPIO11 (pin 54) free for use
<b>closed</b>	I2C Controller interrupt routed to GPIO11 (pin 54)

## Pin descriptions

---

This section provides the pin layout for each item on the development board.

### *ST10 JTAG ICE and ST9 JTAG LPT interfaces*

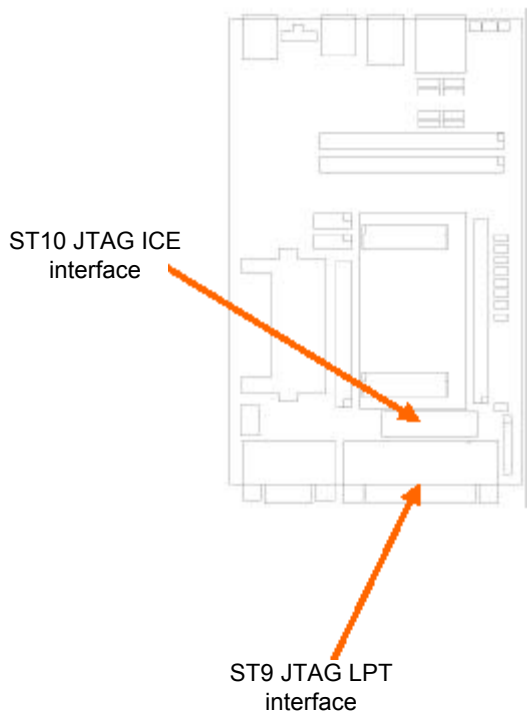

***ST10 JTAG ICE interface pin assignments***

1	3V3	
2	3V3	
3	#TRST	
4	GND	
5	TDI	
6	GND	
7	TMS	
8	GND	
9	TCK	
10	GND	
11	GND	
12	GND	
13	TDO	
14	GND	
15	#SRESET	System reset
16	GND	
17	not connected	
18	GND	
19	not connected	
20	GND	

***ST9 JTAG LPT interface pin assignments***

1	not connected	
2	TCK	
3	TDI	
4	TMS	
5	#TRST	
6	#ENAB	Enable JTAG LPT interface
7	#SRESET	System reset
8	not connected	
9	not connected	
10	not connected	
11	TDO	
12	not connected	
13	connected	
14	not connected	
15	not connected	
16	not connected	
17	not connected	
18	not connected	
19	not connected	
20	GND	
21	GND	
22	GND	
23	GND	
24	GND	
25	GND	

**ST2 RS232 (PXA270 FFUART) and ST12 JTAG Booster interface**

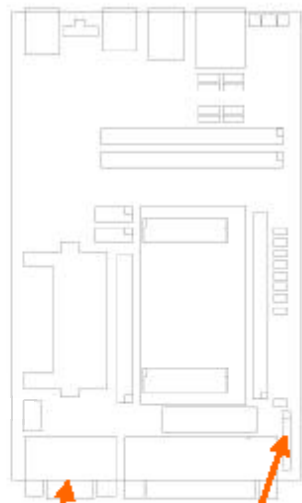

ST2 RS232 (PXA270 FFUART)

ST12 JTAG Booster Interface

**ST2 RS232 (PXA270 FFUART) pin assignments**

1	DCD
2	TxD
3	RxD
4	DSR
5	GND
6	DTR
7	CTS
8	RTS
9	RI

***ST12 JTAG booster interface pin assignments***

1	TCK
2	GND
3	TMS
4	#TRST
5	not connected
6	TDI
7	TDO
8	3V3

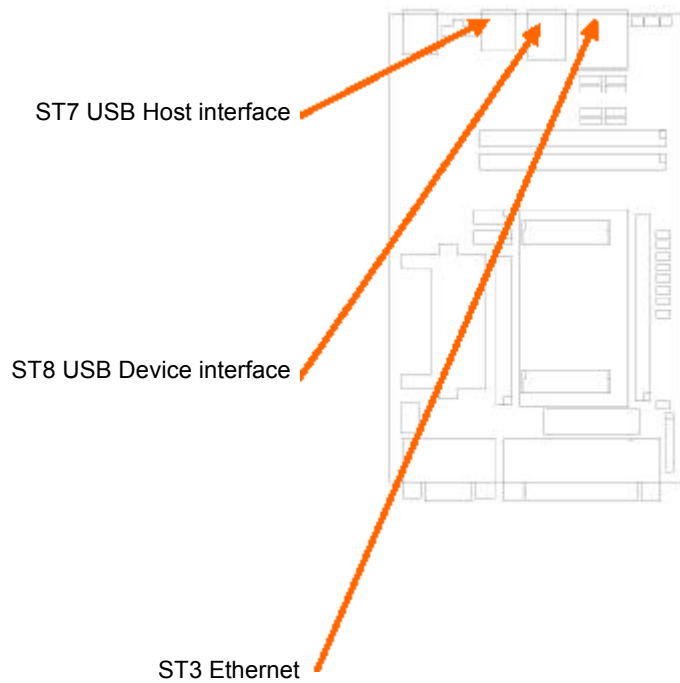
***ST7 USB Host interface, ST8 USB Device interface, and ST3 Ethernet pins***

***ST7 USB host interface pin assignments***

1	5V
2	DATA-
3	DATA+
4	GND

***ST8 USB device interface pin assignments***

1	not connected
2	not connected
3	USB_P
4	USB_N

***ST3 Ethernet pin assignments***

1	RX+ / TX+
2	RX- / TX-
3	TX+ / RX+
4	do not use / do not use
5	do not use / do not use
6	TX- / RX-
7	do not use / do not use
8	do not use / do not use

***X11 LCD 40-pin header pin assignments***

1	GND
2	PCLK
3	LCLK
4	FCLK
5	GND
6	GND
7	LDD[11]
8	LDD[12]
9	LDD[13]
10	LDD[14]
11	LDD[15]
12	GND
13	LDD[5]
14	LDD[6]
15	LDD[7]
16	LDD[8]
17	LDD[9]
18	LDD[10]
19	GND
20	GND
21	LDD[0]
22	LDD[1]
23	LDD[2]
24	LDD[3]
25	LDD[4]
26	GND
27	BIAS

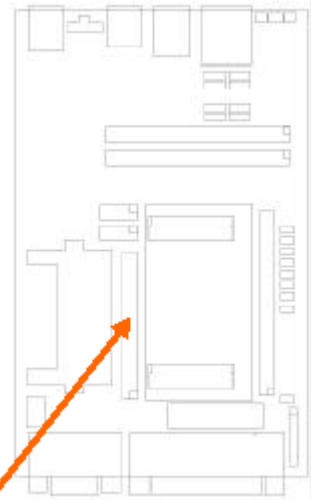

X11 LCD 40-pin header

## Pin descriptions

28	3V3	
29	3V3	
30	GPIO10	
31	GPIO11	
32	BLI_CON	Backlight ON (PCF8574/P4)
33	5V	
34	5V	
35	GND	
36	GND	
37	TSMX	Touchscreen X-
38	TSMY	Touchscreen Y-
39	TSPX	Touchscreen X+
40	TSPY	Touchscreen Y+

***X12 ConnectCore XP 270 X1 50-pin header pin assignments***

1	BITCLK
2	ETNTX-
3	RESERVED
4	ETNTX+
5	SDATA_IN
6	ETNRX-
7	#ACRESET
8	ETNRX+
9	SDATA_OUT
10	ETNLED1
11	GND
12	GND
13	SYNC
14	ETNLED2
15	SDATA_IN0
16	PWM1
17	PWM0
18	SSP_TXD
19	SSP_RXD
20	SSP_FRM
21	SSP_CLK
22	TMS
23	TDO
24	TRST
25	TCLK
26	#RESET_IN
27	TDI

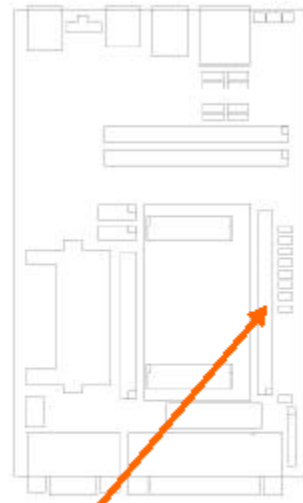

X12 ConnectCore XP 270 X1 50-pin header

28	#RESET
29	GND
30	GND
31	BATT_FAULT
32	RTC_VCC
33	GPIO0
34	BT_RXD
35	GPIO1
36	BT_TXD
37	#EPIOS16
38	BT_CTS
39	#EPWAIT
40	BT_RTS
41	PSKTSEL
42	FF_RXD
43	#PIOW
44	FF_TXD
45	#PCE2
46	FF_DCD
47	#PIOR
48	FF_CTS
49	3V3
50	3V3

**X12 ConnectCore XP 270 X2 50-pin header X21 pin assignments**

1	GND	
2	RD/#WR	
3	SDCKE1	
4	SDCKE0	
5	SDCLK0	
6	GND	
7	SDCLK2	
8	#SDCS3	
9	#SDCS2	
10	#BSDCAS	Buffered #SDCAS
11	GND	
12	#BSDRAS	Buffered #SDRAS
13	#BDQM3	Buffered #DQM3
14	#BDQM2	Buffered #DQM2
15	#BDQM1	Buffered#DQM1
16	#BDQM0	Buffered #DQM0
17	GND	
18	BMA25	Buffered MA25
19	BMA24	Buffered MA24
20	BMA23	Buffered MA23
21	BMA22	Buffered MA22
22	GND	
23	BMA21	Buffered MA21
24	BMA20	Buffered MA20
25	BMA19	Buffered MA19
26	BMA18	Buffered MA18
27	GND	

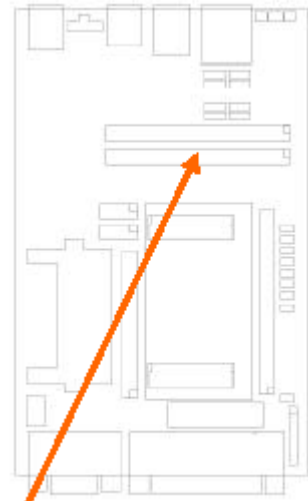

X12 ConnectCore XP  
270 X2 50-pin header

## Pin descriptions

28	BMA17	Buffered MA17
29	BMA16	Buffered MA16
30	DREQ0	
31	BMA15	Buffered MA15
32	BMA14	Buffered MA14
33	BMA13	Buffered MA13
34	BMA12	Buffered MA12
35	GND	
36	BMA11	Buffered MA11
37	BMA10	Buffered MA10
38	BMA9	Buffered MA9
39	BMA8	Buffered MA8
40	GND	
41	BMA7	Buffered MA7
42	BMA6	Buffered MA6
43	BMA5	Buffered MA5
44	BMA4	Buffered MA4
45	GND	
46	BMA3	Buffered MA3
47	BMA2	Buffered MA2
48	BMA1	Buffered MA1
49	MA0	
50	GND1	

***X12 ConnectCore XP 270 X2 50-pin header X22 pin assignments***

1	GND	
2	#BWE	Buffered #WE
3	#OE	
4	RDY	
5	#CS2	
6	GND	
7	#CS3	
8	#CS4	
9	#CS5	
10	MD16	
11	GND	
12	MD17	
13	MD18	
14	MD19	
15	MD20	
16	MD21	
17	GND	
18	MD22	
19	MD23	
20	MD24	
21	MD25	
22	GND	
23	MD26	
24	MD27	
25	MD28	
26	MD29	
27	GND	

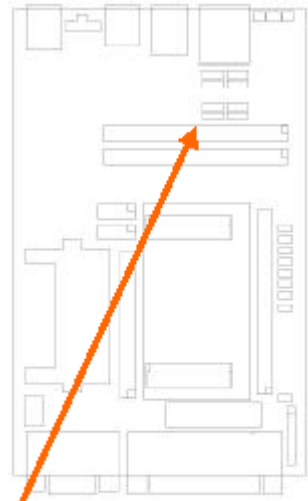

X12 ConnectCore XP 270 X2  
50-pin header X22

## Pin descriptions

28	MD30
29	MD31
30	DREQ1
31	MD15
32	MD7
33	MD14
34	MD6
35	GND
36	MD13
37	MD5
38	MD12
39	MD4
40	GND
41	MD11
42	MD3
43	MD10
44	MD2
45	GND
46	MD9
47	MD1
48	MD8
49	MD0
50	GND

## ***Backlight Inverter Solder Pads, ST6 10-pin header 1, and ST5 10-pin header 2***

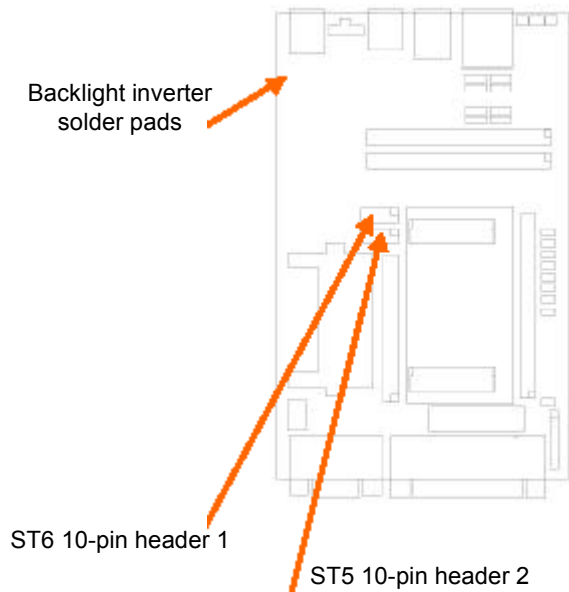

### ***Backlight Inverter Solder Pads pin assignments***

1	5V	
2	GND	
3	BLI_CON	Backlight ON (PCF8574/P4)
4	BLI_CON	Backlight ON (PCF8574/P4)
5	GND	

***ST6 10-pin header 1 pin assignments***

Backlight Inverter and predecoded chip selects

1	5V	
2	5V	
3	#DECO2	0x3080 0000 – 0x30bf ffff
4	#DECO3	0x30c0 0000 – 0x30ff ffff
5	#DECO4	0x3100 0000 – 0x313f ffff
6	#DECO5	0x3140 0000 — 0x317f ffff
7	BLI_CON	Backlight ON (PCF8574/P4)
8	#BUFEN	Enable databus buffer
9	GND	
10	GND	

***ST5 10-pin header 2 pin assignments***

1	IR_TxD
2	IR_RxD
3	FF_RTS
4	#PWE
5	FF_DTR
6	#PREG
7	FF_DSR
8	#POE
9	FF_RI
10	#PCE1

## ConnectCore XP 270 X1 pinout

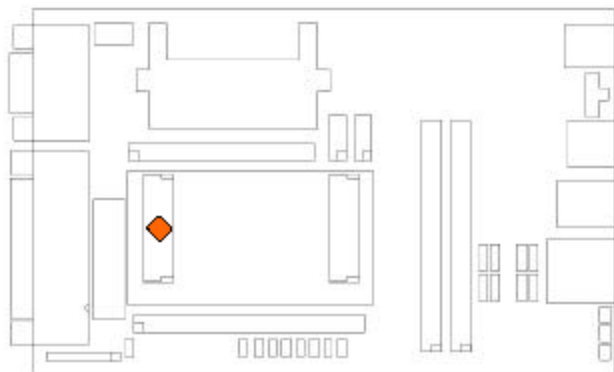

Pin	Signal	Description
1	BITCLK / GPIO28	AC97 Audio Port bit clock (output)
2	ETN_Tx-	Ethernet Transmit Output, negative
3	reserved for future use	
4	ETN_Tx+	Ethernet Transmit Output, positive
5	SDATA_IN1 / GPIO99	AC97 Audio Port data in (input)
6	ETN_Rx-	Ethernet Receive Input, negative
7	ACRESET#	AC97 Audio Port reset signal (output)
8	ETN_Rx+	Ethernet Receive Input, positive
9	SDATA_OUT / GPIO30	AC97 Audio Port data out (output)
10	ETNLED1	Ethernet LED 1
11	GND	GND
12	GND	GND
13	SYNC / GPIO31	AC97 Audio Port sync signal (output)
14	ETNLED2	Ethernet LED 2

Pin	Signal	Description
15	SDATA_IN0 / GPIO29	AC97 Audio Port data in (input)
16	PWM1 / GPIO17	Pulse Width Modulation channel 1
17	PWM0 / GPIO16	Pulse Width Modulation channel 0
18	SSPTXD / GPIO25	Synchronous Serial Port Transmit Pin
19	SSPRXD / GPIO26	Synchronous Serial Port Receive Pin
20	SSPSFRM / GPIO24	Synchronous Serial Port Frame Pin
21	SSPCLK / GPIO23	Synchronous Serial Port Clock Pin
22	TMS	JTAG Test Mode Select
23	TDO	JTAG Test Data Out
24	TRST#	JTAG Test Reset
25	TCK	JTAG Test Clock
26	RESET_IN#	Reset Input
27	TDI	JTAG Test Data In
28	RESET_OUT#	Reset Output
29	GND	GND
30	GND	GND
31	BATT_FAULT	Battery Fault, switch into sleep mode
32	Reserved	Reserved
33	GPIO0	General Purpose I/O-Pin
34	BTRXD / GPIO42	Bluetooth UART Receive Pin (3,3V-Level)
35	GPIO1	General Purpose I/O-Pin
36	BTTXD / GPIO43	Bluetooth UART Transmit Pin (3,3V-Level)
37	PIOIS16# / GPIO57	PCMCIA Interface I/O select 16 Bit
38	BTCTS / GPIO44	Bluetooth UART Clear to Send (3,3V-Level)
39	PWAIT# / GPIO56	PCMCIA Interface Wait
40	BTRTS / GPIO45	Bluetooth UART Ready to Send (3,3V-Level)

Pin	Signal	Description
41	PSKTSEL / GPIO104	PCMCIA Interface Socket Select
42	FFRXD / GPIO53	Full Function UART Receive Pin (3,3V-Level)
43	PIOW# / GPIO51	PCMCIA Interface I/O Write
44	FFTXD / GPIO39	Full Function UART Transmit (3,3V-Level)
45	PCE2# / GPIO54	PCMCIA Interface High Byte Enable
46	FFDCD / GPIO36	Full Function UART Carrier Detect (3,3V)
47	PIOR# / GPIO50	PCMCIA Interface I/O Read
48	FFCTS / GPIO35	Full Function UART Clear To Send (3,3V)
49	+3,3V	power supply
50	+3,3V	power supply
51	+3,3V	power supply
52	+3,3V	power supply
53	NSSP-RXD / GPIO82	NSSP interface
54	FFRI / GPIO38	Full Function UART Ring Ind. (3,3V Level)
55	NSSP-CLK / GPIO84	NSSP interface
56	FFDSR / GPIO37	Full Function UART Data Set Rdy. (3,3V)
57	NSSP-TXD / GPIO81	NSSP interface
58	FFDTR / GPIO40	Full Function UART Data Term. Rdy. (3,3V)
59	NSSP-FRAME / GPIO83	NSSP interface
60	FFRTS / GPIO41	Full Function UART Rdy. To Send (3,3V)
61	GND	GND
62	GND	GND
63	USB_N	USB-Port neg. Pin (3,3V-Level)
64	L_BIAS / GPIO77	LCD bias drive
65	USB_P	USB-Port pos. Pin (3,3V-Level)
66	LDD13 / GPIO71	LCD interface data bus

Pin	Signal	Description
67	SDA / GPIO118	I2C data signal
68	LDD9 / GPIO67	LCD interface data bus
69	SCL / GPIO117	I2C clock signal
70	LDD3 / GPIO61	LCD interface data bus
71	L_LCLK / GPIO75	LCD Interface Line Clock
72	LDD8 / GPIO66	LCD interface data bus
73	LDD1 / GPIO59	LCD interface data bus
74	L_PCLK / GPIO76	LCD Interface Pixel Clock
75	GND	GND
76	GND	GND
77	LDD2 / GPIO60	LCD interface data bus
78	LDD11 / GPIO69	LCD interface data bus
79	L_FCLK / GPIO74	LCD Interface Frame Clock
80	LDD12 / GPIO70	LCD interface data bus
81	LDD5 / GPIO63	LCD interface data bus
82	LDD10 / GPIO68	LCD interface data bus
83	LDD14 / GPIO72	LCD interface data bus
84	LDD15 / GPIO73	LCD interface data bus
85	LDD0 / GPIO58	LCD interface data bus
86	LDD7 / GPIO65	LCD interface data bus
87	GND	GND
88	GND	GND
89	LDD6 / GPIO64	LCD interface data bus
90	IR_RXD / GPIO46	IrDA Receive Pin (3,3V- Level)
91	LDD4 / GPIO62	LCD interface data bus
92	IR_TxD / GPIO47	IrDA Transmit Pin (3,3V-Level)

Pin	Signal	Description
93	PCE1# / GPIO85	PCMCIA Interface Low Byte Enable
94	GPIO34	General Purpose I/O-Pin
95	POE# / GPIO48	PCMCIA Interface Output Enable
96	GPIO10	General Purpose I/O-Pin
97	PREG# / GPIO55	PCMCIA Interface Register Select
98	PWE# / GPIO49	PCMCIA Interface Write Enable
99	GND	GND
100	GND	GND

## ConnectCore XP 270 X2 pinout

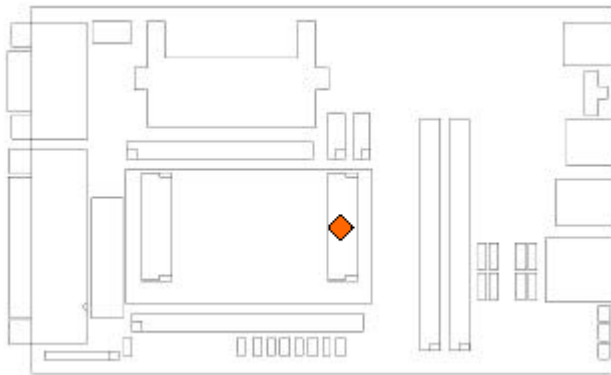

Pin	Signal	Description
1	GND	GND
2	GND	GND
3	RD/WR#	Read not Write

Pin	Signal	Description
4	WE#	Memory Write Enable
5	nSDCKE1	SDRAM device clock enable
6	OE#	Memory Output Enable
7	nSDCKE0 / GPIO106	SMROM or synchronous Flash clock enable
8	RDY / GPIO18	Ready Pin (Wait)
9	SDCLK0	SMROM or synchronous Flash clock
10	nCS2 / GPIO78	Chip Select
11	GND	GND
12	GND	GND
13	SDCLK2	SDRAM banks 2/3 clock
14	nCS3 / GPIO79	Chip Select
15	nSDCS3	SDRAM Chip Select for banks 3
16	nCS4 / GPIO80	Chip Select
17	nSDCS2	SDRAM Chip Select for banks 2
18	nCS5 / GPIO33	Chip Select
19	nSDCAS	SDRAM column address strobe (CAS)
20	MD16	memory data bus
21	GND	GND
22	GND	GND
23	nSDRAS	SDRAM row address strobe (RAS)
24	MD17	memory data bus
25	DQM3	data output byte enable 3
26	MD18	memory data bus
27	DQM2	data output byte enable 2
28	MD19	memory data bus
29	DQM1	data output byte enable 1

Pin	Signal	Description
30	MD20	memory data bus
31	DQM0	data output byte enable 0
32	MD21	memory data bus
33	GND	GND
34	GND	GND
35	MA25	Memory address bus
36	MD22	memory data bus
37	MA24	Memory address bus
38	MD23	memory data bus
39	MA23	Memory address bus
40	MD24	memory data bus
41	MA22	Memory address bus
42	MD25	memory data bus
43	GND	GND
44	GND	GND
45	MA21	Memory address bus
46	MD26	memory data bus
47	MA20	Memory address bus
48	MD27	memory data bus
49	MA19	Memory address bus
50	MD28	memory data bus
51	MA18	Memory address bus
52	MD29	memory data bus
53	GND	GND
54	GND	GND
55	MA17	Memory address bus

Pin	Signal	Description
56	MD30	memory data bus
57	MA16	Memory address bus
58	MD31	memory data bus
59	DREQ0 / GPIO115	DMA Request Channel 0
60	DREQ1 / GPIO97	DMA Request Channel 1
61	MA15	Memory address bus
62	MD15	memory data bus
63	MA14	Memory address bus
64	MD7	memory data bus
65	MA13	Memory address bus
66	MD14	memory data bus
67	MA12	Memory address bus
68	MD6	memory data bus
69	GND	GND
70	GND	GND
71	MA11	Memory address bus
72	MD13	memory data bus
73	MA10	Memory address bus
74	MD5	memory data bus
75	MA9	Memory address bus
76	MD12	memory data bus
77	MA8	Memory address bus
78	MD4	memory data bus
79	GND	GND
80	GND	GND
81	MA7	Memory address bus

<b>Pin</b>	<b>Signal</b>	<b>Description</b>
82	MD11	memory data bus
83	MA6	Memory address bus
84	MD3	memory data bus
85	MA5	Memory address bus
86	MD10	memory data bus
87	MA4	Memory address bus
88	MD2	memory data bus
89	GND	GND
90	GND	GND
91	MA3	Memory address bus
92	MD9	memory data bus
93	MA2	Memory address bus
94	MD1	memory data bus
95	MA1	Memory address bus
96	MD8	memory data bus
97	MA0	Memory address bus
98	MD0	memory data bus
99	GND	GND
100	GND	GND



---

# *ConnectCore XP 270 Customization*

---

## C H A P T E R 3

**T**his chapter provides information for adding custom hardware to the ConnectCore XP 270 development board.

## Adding custom hardware to the development board

---

You can use existing predecoded address areas to connect custom hardware to the ConnectCore XP 270 development board. These decoded address areas are in the PCMCIA socket 1 I/O space.

The development board has buffers for the address and data lines. The ConnectCore XP 270 module signals are connected to flat cable headers. The address and data lines are connected to the headers and routed from the buffers; they are not connected directly to ConnectCore XP 270 pins. These lines, as well as additional signals, are marked as *buffered* on the connector pinout (see "X12 ConnectCore XP 270 X2 50-pin header X21 pin assignments" on page 71).

The lower 16-bit databus buffers are automatically enabled for any access to the PCMCIA bus. If custom hardware is connected to one of the free static memory chip select signals, external hardware must enable the buffers. To enable the databus buffers during accesses to custom hardware, the active low #BUFEN signal must be used. For example, #BUFEN can be connected to the static chip select signal used if that's the only signal used by custom hardware.

Chip selects CS[5:2] should have external 10K pullup resistors if used by custom hardware.

## Custom development board design check list

---

This list provides hints and checkpoints for designing the development board. Use this list to ensure that you are designing the development board correctly and safely.

- 1 **If you use one of the static chip selects CS2# - CS5#, do you have a pull up resistor on this line?** The ConnectCore XP 270 module is provided with a 10K pullup on CS#[5..0]. Only CS#[5..2] are available externally on the module connectors.
- 2 The TRST# signal has a weak pull up on the development board. Intel recommends adding a 1.5 k pull-down resistor to TCK, on the development board.

- 3 If you use the onboard Ethernet controller, check the external magnetics circuitry carefully. The magnetics can be connected to the ConnectCore XP 270 module directly without additional components.
- 4 Check that you have at least one pullup resistor on the RESET\_IN# signal (X1/26.)
- 5 Do you have buffers for the address bus and databus?  
**Note:** There are no buffers on the ConnectCore XP 270 module itself. Use the shortest possible connection for these signals.
- 6 The maximum component height on the baseboard beneath the ConnectCore XP 270 module is 1.1mm.
- 7 **nBATT\_FAULT on connector X1 pin 31 is active low – leave open or tie to VCC if unused!**
- 8 ConnectCore XP 270 signals are not 5V tolerant. Use buffers or level shifters for 5V signal interfacing.



---

# *ConnectCore XP 270 Module Specifications*

---

## A P P E N D I X    A

**T**his appendix provides specifics about the ConnectCore XP 270 module.

## Mechanical dimensions

This is the bottom view of the ConnectCore XP 270 board:

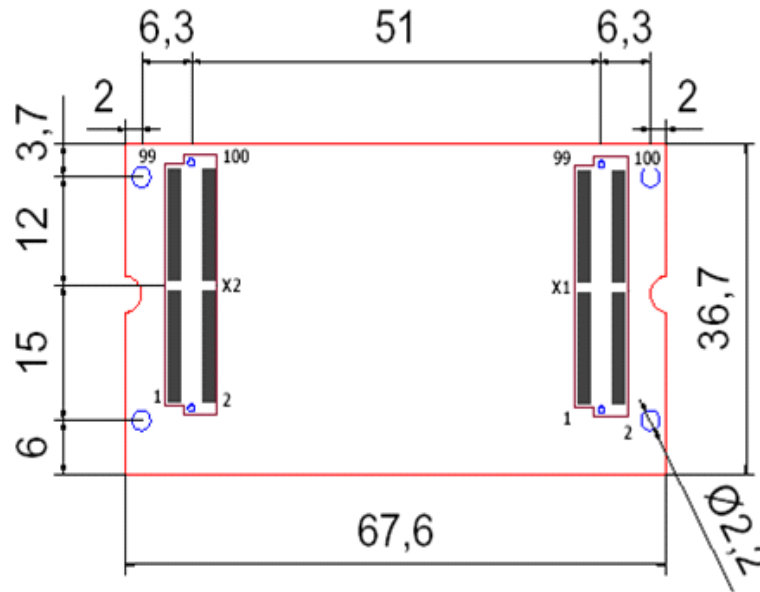

- The connector mates with SAMTEC LSH series (LSH-050-01-G-D-A)
- Mated stack height: 2.31 mm (board to board)
- Maximum component height on base board: 1.0 mm

This drawing shows the board with the SAMTEC LSH-050-01-G-D-A:

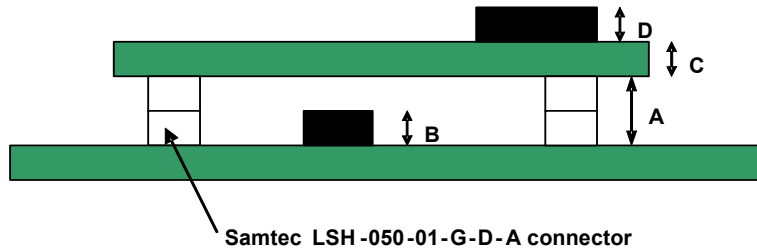

- A: Mated stack height – 2.31mm
- B: Maximum component height under ConnectCore XP 270 module – 1 mm
- C: ConnectCore XP 270 board height – 1.5 mm
- D: SMSC LAN91C111 – 3.4 mm

## Environmental information

The ConnectCore XP 270 board is built with components that all pass the commercial temperature grade (0°C ⇔ 70°C). The chips that limit the operating temperature grade are shown next:

Description	Manufacturer	Operating Temperature
XScale Power Manager, QFN20	Intersil ISL6271ACRZ-T	-25-+85°C
PXA270,PBGA360, 32bit, 520MHz, Stepping C5	Intel NHPXA270C5C520	-25-+85°C (*)

(\*) The operating temperature of the PXA270 is given as Tcase temperature, which means that the current processor is specified for commercial temperature grade only.

## Power requirements

The ConnectCore XP 270 module can impact management; for example, dynamically changing the core voltage. Clock frequency can also affect the current and case temperature of the PXA270 processor, as shown:

Clock frequency	Current needed	Power	Tcase of PXA270	Comments
520 MHz	0.14 A	1680 mW	42.4 °C	All measures have been made with room temperature at 30°C. Temperature measures have been made with Fluke 189 Multimeter and its temperature sensor.

## Layout considerations

When integrating the ConnectCore XP 270, special care must be taken with the Samtec LSH mating connectors. There is a *keep out* area for the layout, defined since Rev. 3 of Samtec's LSH – Surface Mount Footprint definition. Note the connector's profile shown next; there are two lead areas at the same level:

- The outer area is used for soldering.
- The inner area gives mechanical stability.

**Note:** In the case of copper on the PCB in the inner area, the soldermask is the only isolator and there is risk of a short circuit.

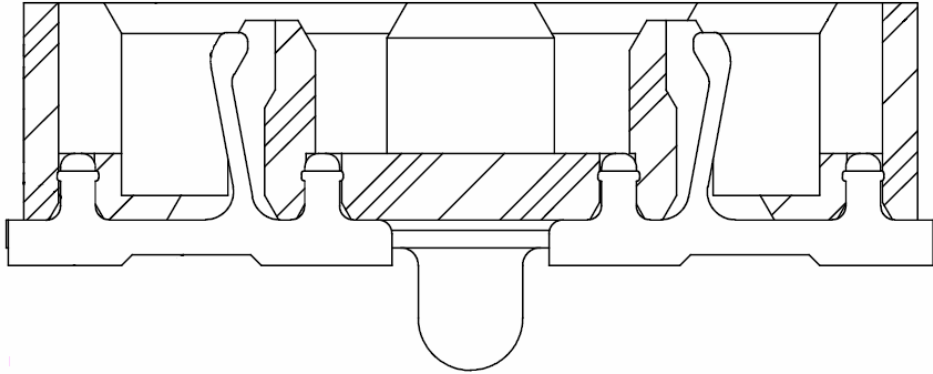

If all trace need to be routed inside the connector's footprint, it must be ensured that only copper of the same net exists under each lead. If small vias are used, the fanout for all pads can be made completely inside the part outline. This example shows the LSH footprint and the two lead areas in red.

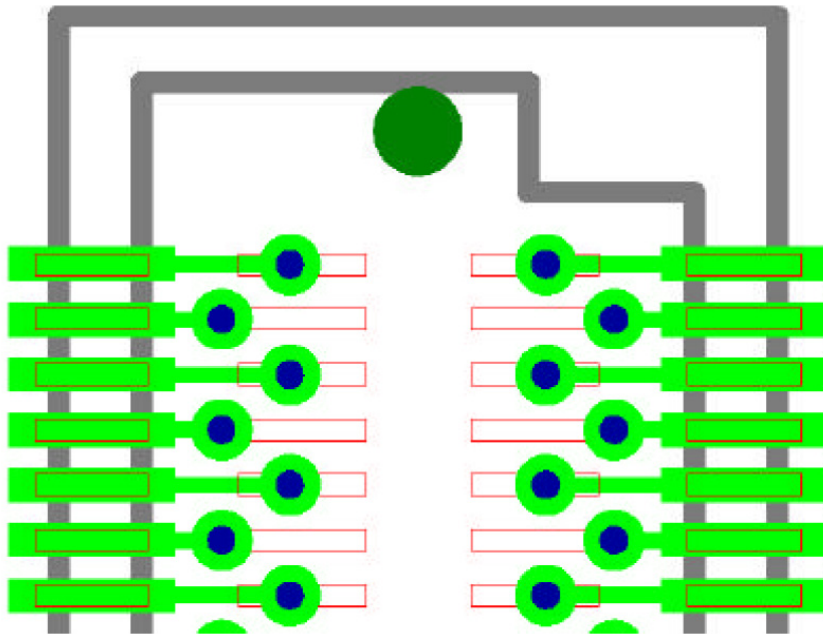



---

# *JTAG-Booster for Intel XScale PXA270*

---

## A P P E N D I X B

**T**his appendix describes the JTAG booster as it is used with the Intel XScale PXA270 and the ConnectCore XP 270 module; in particular, using this tool to program flash memory.

## Overview

---

The program JTAG270.EXE uses the JTAG port of the Intel XScale PXA270 processor in conjunction with the small JTAG-Booster to perform these functions:

- Program data into flash memory
- Verify and read the contents of a flash memory
- Make a memory dump
- Access an I<sup>2</sup>C Device
- Test CPU signals

All functions are done without any piece of software running in the target. No firmware or BIOS must be written. Bootstrap software may be downloaded to initially unprogrammed memories.

The JTAG-BOOSTER' s software is highly optimized to the JTAG chain of a specific target CPU.

**Boundary Scan** mode is extremely robust and may work on totally new and untested hardware. When you are bringing up new hardware or you are using this tool for the first time, you should start by using this standard mode.

**OnChip Debug (OCD)** mode allows higher download speed, but is more complex and relies on already working hardware.

## System requirements

---

These are the system requirements for running this tool successfully:

- MSDOS, WIN3.x, WIN9x, WinNT, Win2000 or WindowsXP (You need an additional tool to support WinNT/Win2000/WindowsXP; "Support for Windows NT, Windows 2000 and Windows XP," beginning on page 107.)
- Intel 80386 or higher
- 205 kByte of free DOS memory
- Parallel Port

## CD files

---

These files can be found on the CD in the JTAG directory.

- JTAG270.EXE
- JTAG270.OVL
- jtag270.ini
- jtag270.cfg
- proguboot.bat
- winnt21.zip

## Connecting your PC to the target system

---

The JTAG-Booster can be plugged into standard parallel ports (LPT1-3) with a DB25-Connector.

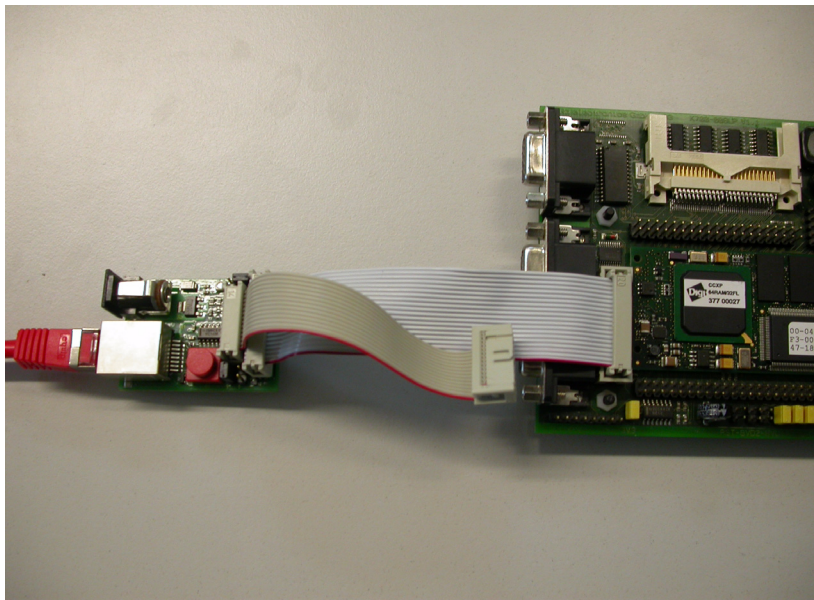

The 3.3V version of the JTAG-Booster (FS part number 285) is delivered together with this package. Don't use the 5V version of the JTAG-Booster (FS part number 227) with a 3.3V target. **Don't apply 5V to the 3.3V version of the JTAG-Booster**

- Your target must be able to power the JTAG-Booster; it draws about 100mA.
- Before you start the program, the JTAG-BOOSTER must be plugged to a parallel interface of your PC and to the target.
- The utility is started with the general command line format: JTAG270  
                   JTAG270 /function [filename] [/option\_1] ... [/option\_n]
- Note that the function must be the first argument, followed (if needed) by the filename.
- If you want to cancel execution of JTAGxxx, press CTRL-Break-Key.
- With any error, the program aborts with an MSDOS error level of one.

## Initialization file JTAG270.INI

The initialization file defines the default direction and level of all CPU signals. This file *must be carefully adapted* to your design with the Intel XScale. The Target-Entry identifies your design, which is displayed with most commands.

When the program JTAG270.EXE is started, it scans the current directory for an existing initialization file named JTAG270.INI. If no entry is found, the default values are used. You can also specify the initialization file with the option /INI=. If the specified file isn't found, the program aborts with an error message.

The CPU pins can also be used with the functions /BLINK, /PIN? and /SAMPLE to test the signals on your design.

Add remarks using //.

## Supported Flash devices

Type JTAG270 /LIST [optionlist] to get an online list of all flash types that can be used with the /DEVICE= option.

## JTAG270 Parameter Description

When you start JTAG270.EXE without any parameters, a help screen appears with all possible functions and options:

```
JTAG270 --- JTAG utility for Intel PXA27x
Copyright (C) FS FORTH-SYSTEME GmbH, Breisach
Version 4.xx of xx/xx/xxxx
```

Programming of Flash-EPROMs and hardware tests on targets with the Intel PXA27x.

The JTAG-Booster is needed to connect the parallel port of the PC to the JTAG port of the Intel PXA27x.

Usage: JTAG270 /function [filename] [/option\_1] ... [/option\_n]

Supported functions:

```
/P   : Program a Flash Device
/R   : Read a Flash Device to file
/V   : Verify a Flash Device with file
/DUMP : Make a target dump
/PSER : Program a I2C/SPI/MicroWire Device with file
/RSER : Read a I2C/SPI/MicroWire Device to file
/VSER : Verify a I2C/SPI/MicroWire Device with file
/DUMPSER: Make a dump of a I2C/SPI/MicroWire device
/BLINK : Toggle a CPU pin
/PIN? : Test a CPU pin
/SAMPLE : Test a CPU pin while CPU is running
/SNAP : Test all CPU pins while CPU is running
/LIST : Print a list of supported Flash devices
```

Supported Options:

```
/CS0      /CS1      /CS2      /CS3      /CS4
/CS5      /FAST     /FAST=    /OCD      /NOCS
/NOWRSETUP /NORAM    /RESET    /RESUME   /TOP
/BYTE-MODE /BM       /CFI      /CFIDEBUG /PAUSE
/P        /NODUMP   /NOERASE  /ERASEALL /NOWRBUF
/LATTICE  /WIGGLER /PLS      /TRITON1  /TRITON2
/TRITON3  /LPT1    /LPT2    /LPT3     /LPT-BASE=
/32BIT    /16BIT   /8BIT    /NOMAN    /LENGTH=
/L=       /FILE-OFFSET= /FO=     /OFFSET=  /O=
/DELAY=   /DEVICE-BASE= /DB=     /DRIVER=  /IROFFS=
/CPUPOS=  /DEVICE=   /PIN=    /SERCS=   /SERCLK=
/SERDAT=  /SERDATI= /SERDATO= /SERBUFF= /SERBIG
/SPI      /MWIRE    /DFLASH  /LSB1ST  /SPIERA
/WATCH=   /OUT=     /INI=    /CFG=    /SCR=
/REP
```

These options are the most important parameters for using JTAG270 software:

**/DRIVER=x with x = 1,2,3,4**

You can specify a driver for the interface to the JTAG-BOOSTER on the parallel port. /DRIVER=1 selects the fastest available driver; /DRIVER=4 selects the slowest one. Use a slower driver if there are problems with JTAG-BOOSTER.

Default: /DRIVER=1

**/INI=file**

You can specify an initialization file. By default, the current directory is searched for the file JTAG270.INI. If this file is not found and no initialization file is specified in the command line, default initialization values are used.

**Note:** The initialization file is not loaded for the functions /SAMPLE and /SNAP.

Default: /INI=JTAG270.INI

**/LATTICE**

Along with the standard JTAG-Booster interface, several simple “Parallel-Port-JTAG” interfaces are supported. With these interfaces, though, programming performance is reduced.

**/LPT1 /LPT2 /LPT3**

You can specify a printer port where the JTAG-Booster resides. If you are using this program with WinNT, Win2000, or WinXP, you must specify /LPT2 or /LPT-BASE=378 to get access to the standard printer port.

**/LPT-BASE**

You can specify the physical I/O address of the printer port instead of the logical printer name. This option is useful if you work with WinNT, Win2000 or Windows XP, because the standard printer port is mapped as LPT2 here.

Use the option /LPT-BASE=378 to get a command line that works independent of the operation system.

## Program a Flash Device

---

### Use: JTAG270 /P filename [optionlist]

The specified file is programmed into the flash memory. The flash status is polled after each cell is programmed (cell = 8-, 16- or 32-bit, depending on current data bus width). In the case of a programming error, the contents of the flash memory are written to a file with the extension DMP.

For a complete verify after programming, use an additional command line with the verify function. In most cases, this additional verify step is not needed.

Software normally detects the type of the flash device. When auto-detection fails, you should use the `/DEVICE=` option together with `/8BIT` or `/16BIT` or `/32BIT` to set the right flash device and configuration.

### Options

#### ***/DEVICE=devicename***

The flash device is detected automatically by switching to auto-select mode. In case of trouble, select the flash device using this parameter to avoid auto-detection. Combine this option with one of the following options that specify the data bus width and the option `/BYTE-MODE`, if applicable.

#### ***/8BIT /16BIT /32BIT***

Specifies the data bus width to the target flash device. You can speed up auto-detection if you specify the correct data bus size. You need this option together with the `/DEVICE=` option to explicitly specify a particular flash configuration.

#### ***/BYTE-MODE***

If there is a flash device connected to the CPU, which has a byte mode pin (8 bit and 16/32 bit bus mode), you can force it to be used as 8 bit mode with the option `/BYTE-MODE`. In most cases, this option will not be needed.

#### ***/CFI***

To be prepared for future flash chips, the JTAG-Booster integrates support for flashes that contain the CFI (Common Flash Interface) information structure. CFI support is

activated by adding the option `/CFI` to the command line. The JTAG-Booster then automatically searches in all available bus widths for all possible flash types and configurations instead of searching for the JEDEC identification code.

In case of an error, add the command line option `/CFIDEBUG` and redirect the program output into a file. Sending Digi this file helps in solving problems.

### ***/NOMAN***

If you use a flash device that is identical to one of the supported parts but is from a different manufacturer, use this option to suppress the comparison of the manufacturer identification code. It is recommended that you use this option with the `/DEVICE=` option to avoid failures in auto-detection.

### ***/DEVICE-BASE=hhhhh***

Use this option to specify a flash device starting address. In most cases, where the flash device is selected with one of the CPU's chip select pins, this parameter is not needed. If there is any decoding logic in your hardware, however, this option is necessary. This option is especially useful when there are several flash banks connected to one chip select and a sub decoding logic generates chip selects for these flash banks; this option can select a specific flash bank.

Default: `/DEVICE-BASE=0`

Abbreviation: `/DB=`

### ***/OFFSET=hhhhh***

The programming starts at an offset of `hhhhh` relative to the start address of the flash device. If the offset is negative, the offset specifies an address relative to the end of the flash device. See `"/TOP"` on page 104 for more information.

Default: `/OFFSET=0`

Abbreviation: `/O=`

### ***/TOP***

If the `/TOP` option is used, the `/OFFSET=` option specifies the address where the programming ends (plus one) instead of the starting address. This option is very

important for Intel CPU architectures, because target execution always starts at the top of the address space.

### ***/FILE-OFFSET=hhhhh***

If `FILE-OFFSET` is specified, the first `hhhhh` bytes of the file are skipped and not programmed to target.

Default: `/FILE-OFFSET=0`

Abbreviation: `/FO=`

### ***/LENGTH=hhhhh***

The number of programmed bytes can be limited to `LENGTH`. If no `LENGTH` is specified, the whole file is programmed.

Default: `/LENGTH=4000000` (64 MByte)

Abbreviation: `/L=`

### ***/NODUMP***

In case of a verify error, the contents of the flash memory is written to a file with the extension `.DMP`. With `/NODUMP`, you can suppress this feature.

### ***/ERASEALL***

`/ERASEALL` erases the whole flash device. If this option isn't set, only those blocks are erased where new data should be written.

### ***/NOERASE***

`/NOERASE` prevents the flash device from being erased.

### ***/CS0 /CS1 /CS2 /CS3 /CS4 /CS5***

This options specifies one or more chip select signals to the flash memory. The used chip selects must be defined as output and inactive in the initialization file.

## Example with Intel PXA270

---

In this simple example, it is assumed that the JTAG-Booster is connected to LPT1 of your PC and target power is on.

Typing

```
JTAG270 /P MYAPP.BIN
```

at the DOS prompt results in the following output:

```
JTAG270 --- JTAG utility for Intel PXA270
Copyright © FS FORTH-SYSTEME GmbH, Breisach
Version 4.xx of mm/dd/yyyy
```

- (1) Configuration loaded from file JTAG270.INI
- (2) Target: Generic Target
- (3) Using LPT at I/O-address 0378h
- (4) JTAG Adapter detected
  
- (5) 1 Device detected in JTAG chain
- (6) Device 0: IDCODE=49265013 Intel XScale PXA27x, Revision 4
- (7) Sum of instruction register bits: 7
- (8) CPU position: 0
- (9) Instruction register offset: 0
- (10) Length of boundary scan reg: 504

```
Looking for a known flash device. Please wait..
```

- (11) Dual Intel 28F128 StrataFlash, 3.3V detected
  - (12) Bus size is 32 Bit
  - (13) Erasing Flash-EPROM Block #:0
- ```
Programming File MYAPP.BIN
65536 Bytes programmed successfully
```

```
Erase Time:          0.8 sec
```

```
Programming Time:   xx.9 sec
```

- 1** The initialization file JTAG270.INI was found in the current directory.
- 2** The target identification line of the initialization file is printed here.

- 3 The resulting I/O-address of the parallel port is printed here.
  - 4 A JTAG-Booster is found on the parallel port
  - 5 The JTAG chain is analyzed. There may be several parts in the JTAG chain. The chain is analyzed and all parts except the Intel PXA27x are switched to bypass mode.
  - 6 The revision (1<sup>st</sup> digit of the ID) shows the mask stepping:  
Revision 3 → PXA270 C0 BGA  
Revision 4 → PXA270 C0 MCP
  - 7 The length of all instruction registers in the JTAG chain are added.
  - 8 The position of the Intel XScale in the JTAG chain is assumed to be zero, if not specified in the command line (see option /CPUPOS=).
  - 9 The position of the JTAG instruction register of the Intel XScale is assumed to be zero, if not specified in the command line (see option /IROFFS=).
  - 10 The real length of the boundary scan register is displayed here and compared with the boundary scan register length of an Intel PXA270.
  - 11 Two Flashes Intel 28F128 selected with CS0# where found.
  - 12 The resulting data bus size is printed here.
- In this example one block must be erased.

## Support for Windows NT, Windows 2000 and Windows XP

A configured run time version of the “Kithara DOS Enabler, Version 6.x” is used to give support for some of the DOS based tools (such as the JTAG-Booster) for Windows NT, Windows 2000, and Windows XP. After installation of the “DOS Enabler,” the accesses to the LPT ports are allowed for all programs listed in file `Readme_WinNT.txt`

**Note:** Accesses to the ports are allowed only for the programs listed in file `Readme_WinNT.txt`. If you rename one of the Digi tools, the DOS Enabler does not work.

**Important:** You need administrator rights to install or uninstall this program.

## Installation on a clean system

If you have a clean system without having installed a previous version of the “Kithara Tool Center”, this tool is very simple to install:

- 1 Extract the ZIP file (winnt21.zip) to a new folder and start KSETUP.EXE. Everything is done within a few seconds. No additional input is needed.
- 2 Reboot your PC.

## Installation with an already installed version 5.x/6.x of Kithara

If you have already installed an older WinNT support (Kithara Version 5.x or 6.x), you have to uninstall that version first.

To uninstall the runtime version of the “Kithara DOS-Enabler Version 5.x/6.x”:

- 1 Use Settings → Control-Panel → Add/Remove Programs.
- 2 Remove “FS FORTH-SYSTEME WinNT Support” and/or “WinNT Support for JTAG-Booster and FLASH166”
- 3 Reboot your PC

After rebooting your PC, you can install the Kithara as described in “Installation on a clean system”s.

# Index

---

## Numerics

- 1-wire EEPROM 12
- 1-wire EEPROM memory map 13

## A

- AC'97 controller 27
- adding custom hardware 88

## B

- backlight inverter solder pads 75
- bidirectional GPIOs 37
- Bluetooth UART (BTUART) 20

## C

- chip select use 5
- clock signals 7
- CompactFlash interface 22
- ConnectCore XP 270
  - development board 53
  - development board diagram 54
  - hardware block diagram 58

- installation 55–57
- memory map 48
- ConnectCore XP 270 GPIO use 37
- ConnectCore XP 270 GPIOs 36
- ConnectCore XP 270 module
  - block diagram 5
  - definition 1
  - features 3
- ConnectCore XP 270 X1 77
- ConnectCore Xp 270 X2 81
- connector pinout 28
- connector X1 pinout 28
- connector X2 pinout 33
- custom development board check list 88

## D

- Digi customer support ix

## E

- environmental information (module) 93
- Ethernet controller 9
  - external schematics 10
- Ethernet magnetics selection 59

## **F**

flash memory 7  
full-function UART (FFUART) 20

## **G**

GPIO controller register summary 46  
GPIOs used internally 47

## **I**

I2C bus interface 22  
installation  
    replacing the module 55  
    setting up basic and optional  
        connections 57  
Intel XScale 52  
Intel XScale PXA270 processor  
    block diagram 3  
    features 2  
    power management chip 8  
IrDA UART 20

## **J**

JTAG-Booster for Intel XScale PXA270 97–  
108  
jumpers 59

## **L**

layout considerations 94  
LCD controller 24  
LEDs 59

## **M**

mechanical dimensions (module) 92  
MultiMedia Card / SD / SDIO controller +  
Memory Stick 23

## **P**

PC card 22  
PC card memory map 23  
pin descriptions 61  
power requirements (module) 94  
pulse width modulator controller 27

## **Q**

qualified magnetics 11

## **R**

reset logic 6

## **S**

SDRAM memory 7  
SSP serial ports 21  
ST10 JTAG ICE interface 61  
ST12 JTAG Booster interface 64  
ST2 RS232 (PXA270 FFUART) interface 64  
ST3 Ethernet pins 65  
ST5 10-pin header 2 75  
ST6 10-pin header 1 75  
ST7 USB Host interface 65  
ST8 USB Device interface 65  
ST9 JTAG LPT interface 61  
suggested magnetics 11

## U

UARTs 20

USB 14–20

    ConnectCore XP 270 15–20

        charge pump device 19

        multiplexing mechanism 17

        OTG transceiver 18

        USB transceiver 20

    Intel PXA270 USB 14–15

        USB client controller features 14

        USB Host controller features 15

        USB Host ports 14

        USB On-The-Go operation 15

## W

watchdog unit 6

## X

X11 LCD 40-pin header 67

X12 ConnectCore XP 270 X1 50-pin  
header 69

X12 ConnectCore XP 270 X2 50-pin  
header 71

X12 ConnectCore XP 270 X2 50-pin header  
X22 73

