



Drop-in Networking

GETTING STARTED GUIDE

802.15.4 Series



© Digi International Inc. 2008. All Rights Reserved.

Digi, Digi International, the Digi logo, ConnectPort, Watchport, and XBee, are trademarks or registered trademarks of Digi International, Inc. in the United States and other countries worldwide.

All other trademarks are the property of their respective owners.

Information in this document is subject to change without notice and does not represent a commitment on the part of Digi International.

Digi provides this document “as is,” without warranty of any kind, either expressed or implied, including, but not limited to, the implied warranties of fitness or merchantability for a particular purpose. Digi may make improvements and/or changes in this manual or in the product(s) and/or the program(s) described in this manual at any time.

This product could include technical inaccuracies or typographical errors. Changes are periodically made to the information herein; these changes may be incorporated in new editions of the publication.

OBJECTIVES

Upon completing this Starter Kit, you will be able to:

- Set up a Drop-in Network
- Discover wireless devices in a Drop-in Network
- Assign names to wireless devices in a Drop-in Network
- Retrieve data from a wireless device over an IP network
- Send data to a wireless device over an IP Network
- Know the tools and resources available for extending the Drop-in Network through customized embedded applications

QUESTIONS?

For technical assistance with your Drop-in Network, call:

1-800-903-8430 (US Only)

Digi contact numbers outside US:

Country	Toll Free Number
Argentina	00-800-3444-3666
Australia	0011-800-3444-3666
Brazil	0021-800-3444-3666
China North	00-800-3444-3666
China South	00-800-3444-3666
France	00-800-3444-3666
Germany	00-800-3444-3666
Hong Kong	001-800-3444-3666
India	000-800-100-3383
Israel	00-800-3444-3666
Italy	00-800-3444-3666
Japan	For calls from KDD fixed land-line phones: 010-800-3444-3666 From KDD public and mobile phones: 001-010-800-3444-3666 For non-KDD phones: 122-001-010-800-3444-3666
Korea	002-800-3444-3666
Mexico	001-800-903-8430
Netherlands	00-800-3444-3666
New Zealand	00-800-3444-3666
South Thailand	001-800-3444-3666
Spain	00-800-3444-3666
United Kingdom	00-800-3444-3666

Contents

QUESTIONS?	4
Digi contact numbers outside US:	4
Drop-in Networking definitions	7
1. Start the Drop-in Network	9
Connect and power on the gateway	10
Connect and power on XBee Adapters	12
XBee Sensor Adapter	12
XBee RS-232 Adapter	14
Access the gateway's web interface.....	16
Find the XBee Adapters in the Drop-in Network.....	17
Optional: Assign names to Drop-in Network devices	19
Install and run the demo application.....	22
Install	22
Search for and display nodes	23
Read the temperature from the temperature sensor	24
Display the temperature	24
Refresh the temperature display	24
Exercise the terminal function	25
How did this demo application work?	27
Want to learn more?	27
2. Extend the Drop-in Network with Embedded Development	29
OBJECTIVES	29
Connect and power on interface boards.....	30
XBee interface board, AC-powered.....	30
XBee interface board, battery-powered.....	31
LEDs and buttons	32
Configure low-power mode for battery-powered interface board	34
Install X-CTU software.....	34
Start X-CTU and establish communication with XBee interface board....	34
Program the XBee module to low-power sleep mode	35
Verify XBee interface board operation.....	36
Embedded development resources.....	37
Software	37
Documentation and help.....	37
Order additional Drop-in Networking products.....	38
Examples of embedded development efforts	39
Modify the PC demo application.....	39
Create new applications	39
Exercise serial connections	39
Experiment with additional sensors	39

Plan, deploy, and manage Drop-in Networks	41
Use Digi planning, commissioning, and deployment tools	41
Use Connectware Manager	42
Mesh Networks/WPAN view	42
Detailed node views	43
Digi Connectware Manager product information	43

Drop-in Networking definitions

This guide uses several terms to describe the networks, connectivity, and data communications involved in Drop-in Networking. The figure shows a ConnectPort X device and its role in Drop-in Networking connectivity.

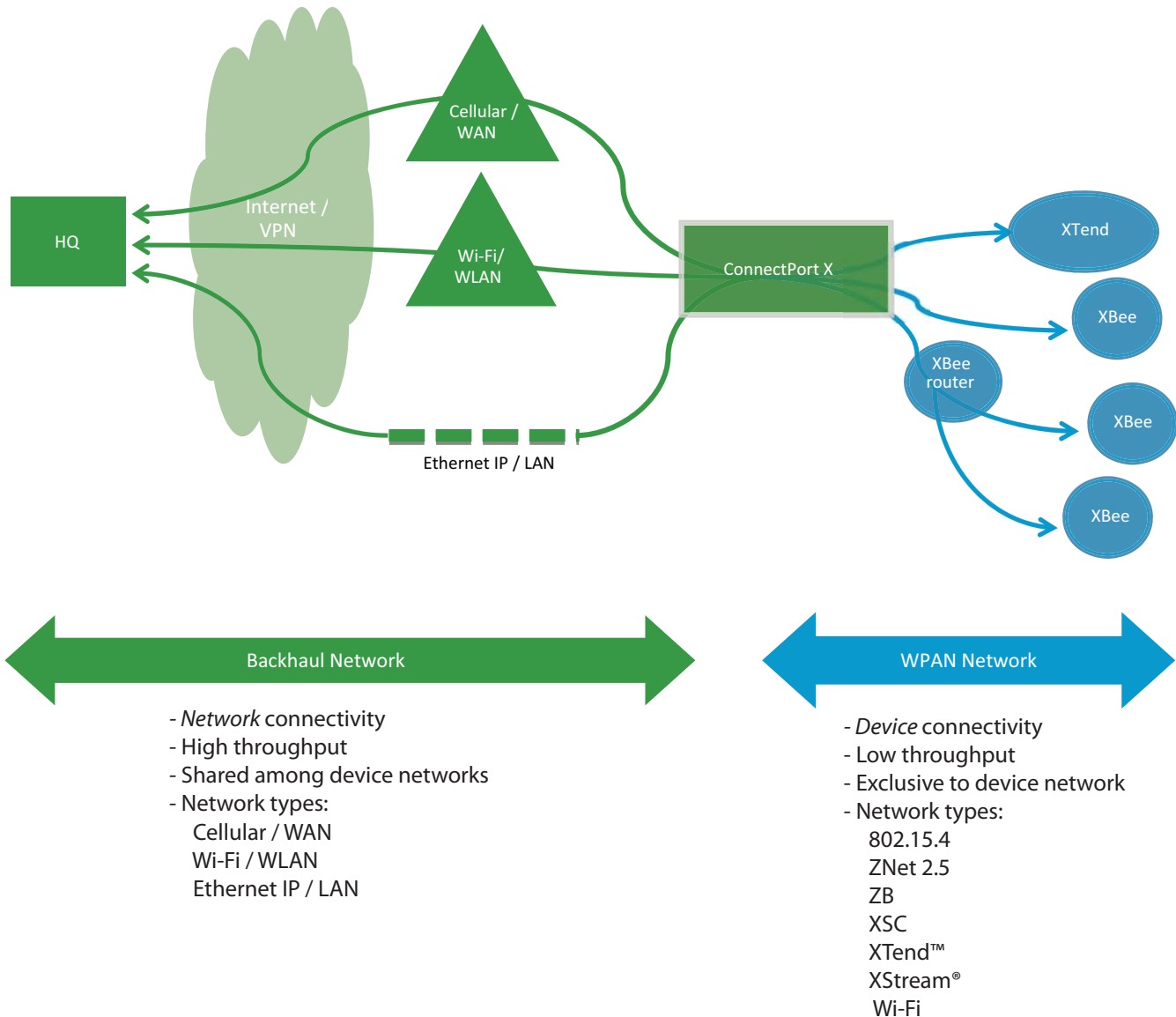

Drop-in Networking: Involves *end-to-end device-to-network connectivity*, commonly through gateways, routers, adapters, and embedded modules.

Backhaul network: Involves *network connectivity*, commonly through LAN (Ethernet), WLAN (WiFi), or WAN (cellular).

WPAN (Wireless Personal Area Network): involves *end device connectivity*, commonly through ZigBee, 802.15.4, and many other public or proprietary technologies.

1. Start the Drop-in Network

There are two sets of equipment in the Starter Kit:

1. Start the Drop-in Network

These Starter Kit boxes contain the devices to start the Drop-in Network.

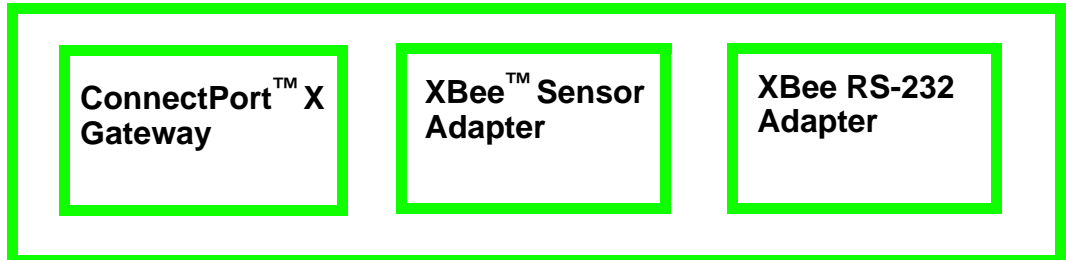

You will also need:



A PC, configured to obtain an IP address automatically

Hardware & Software Setup CD



Digi ConnectPort X gateways are available in multiple configurations: WPAN-to-Ethernet, WPAN-to-Wi-Fi, and WPAN-to-Cellular. The latter two configurations enable end-to-end wireless device connectivity.

2. Extend the Drop-in Network with Embedded Development

These boxes contain equipment and accessories for developing embedded applications.

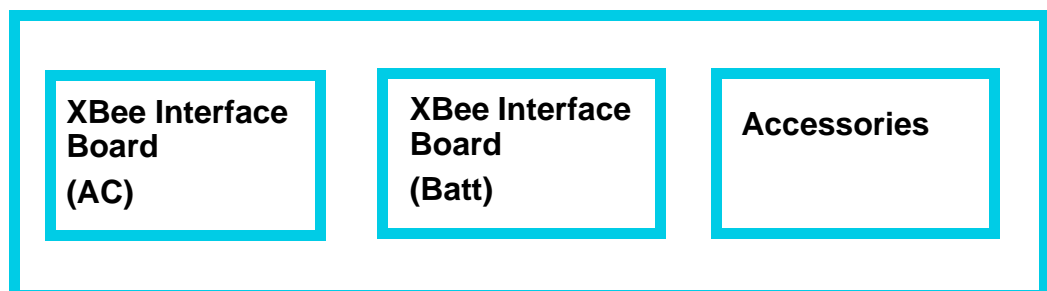

Connect and power on the gateway

1. Open and unpack the box labeled **ConnectPort X Gateway**.
2. Connect the power supply to the ConnectPort X8 gateway and turn the connector clockwise to tighten.

Note (International version only): Connect the power supply to a power cord (not included), and the power cord to the outlet.

The green **Power** light on the front of the gateway indicates that the device is on.

3. Connect the crossover Ethernet cable to the **Ethernet** port of the gateway, and the other end to the Ethernet port of the PC.
4. Connect the antenna to the **WPAN** or **ZigBee** connector, depending on the connector label on the gateway. Turn the connector clockwise to tighten.

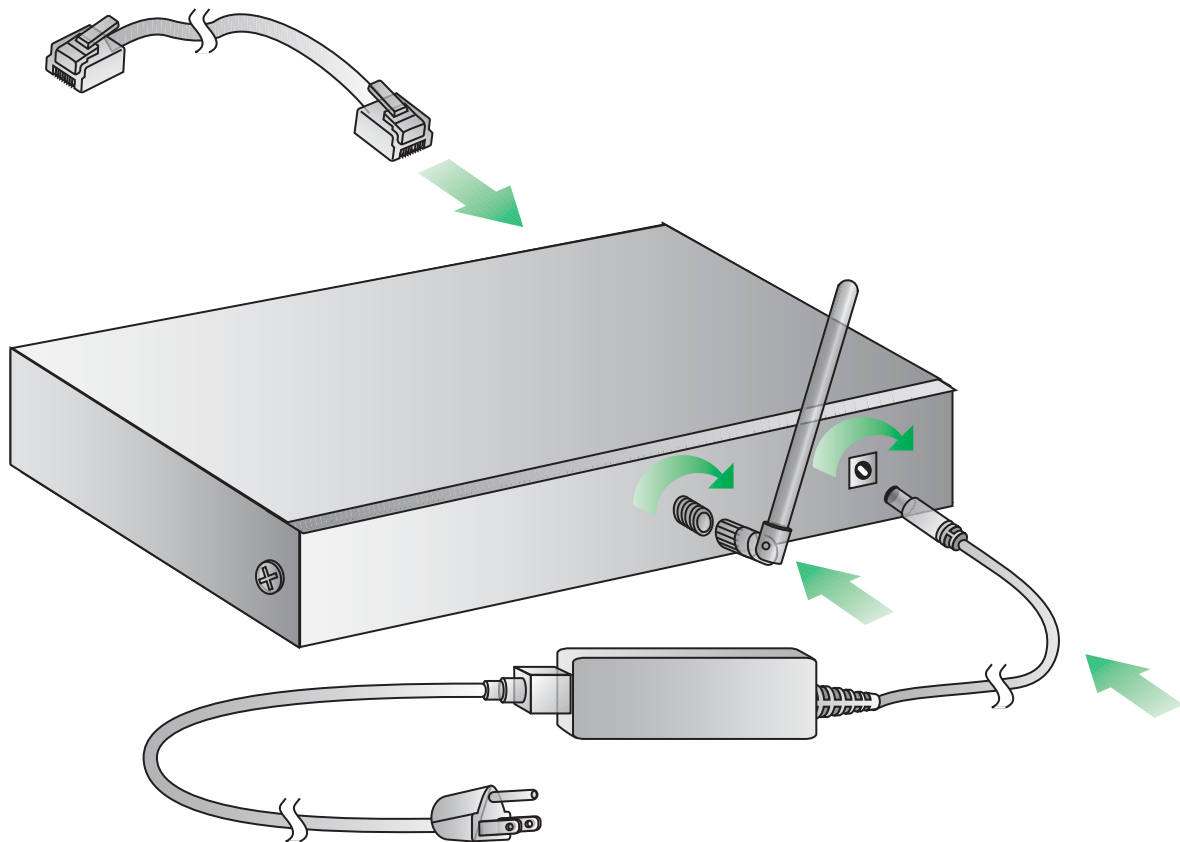

1

Now your network looks like this:

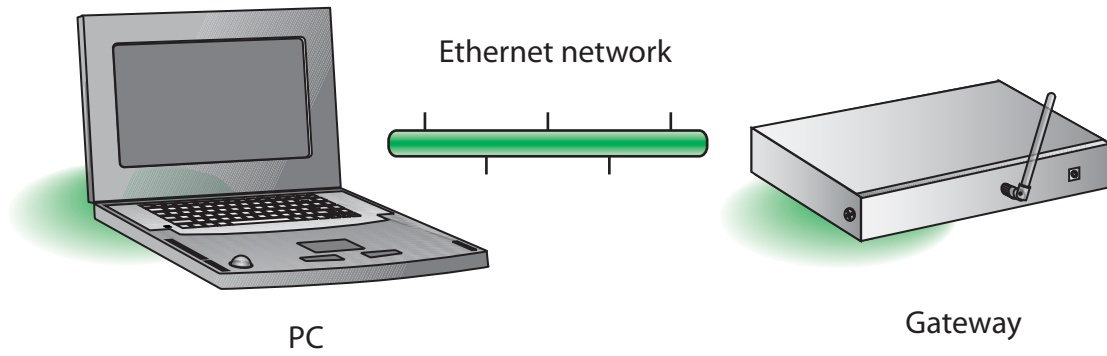

1. Start the Drop-in Network

Connect and power on XBee Adapters

XBee Sensor Adapter

1. Open and unpack the box labeled **XBee Sensor Adapter**.
2. Connect the Watchport[®]/T temperature sensor to the **SENSOR** port of the XBee Sensor Adapter.
3. Connect the power supply to the adapter. Turn the connector clockwise to tighten.

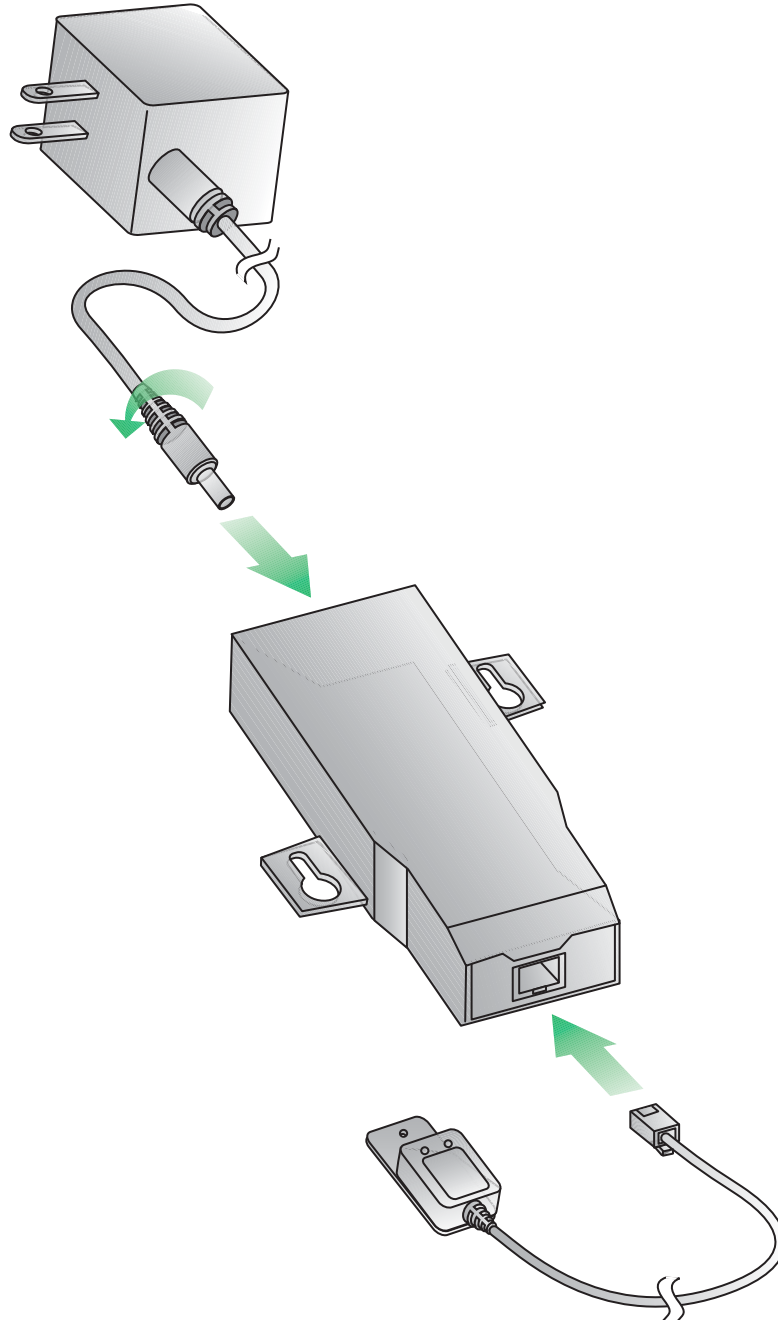

1

The **Power** light on the power-connector end of the adapter indicates that the power is on.

The **Assc** (associate) light indicates that the adapter is active.

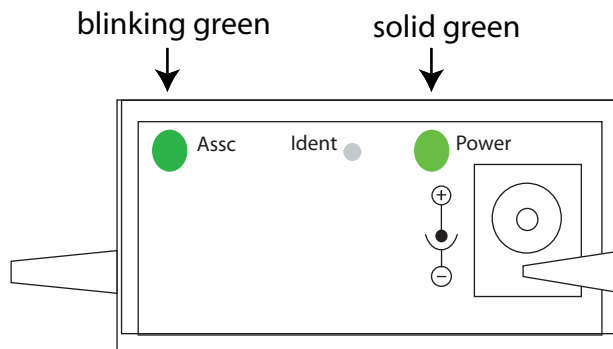

1. Start the Drop-in Network

XBee RS-232 Adapter

1. Open the box labeled **XBee RS-232 Adapter**.
2. Connect the loopback plug to the serial port of the XBee RS-232 Adapter.
3. Connect the power supply to the adapter. Turn the connector clockwise to tighten.

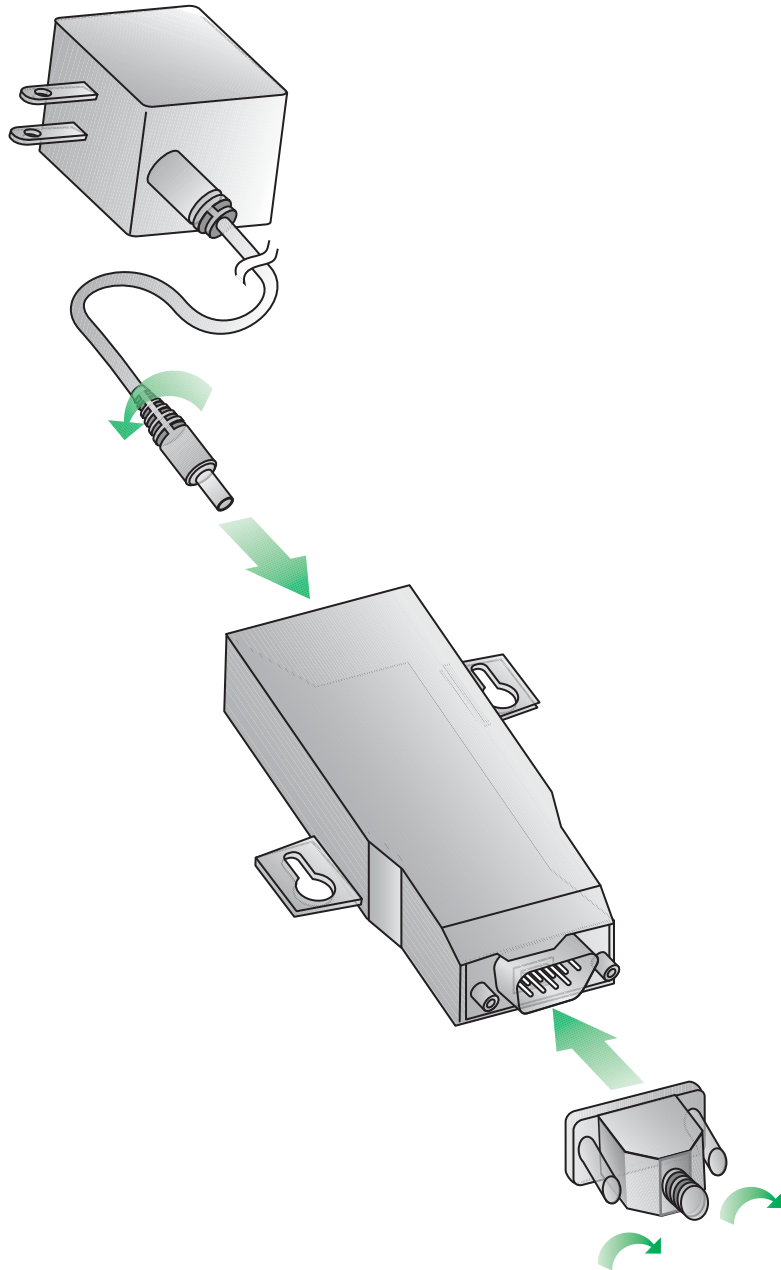

1

The **Power** light on the power-connector end of the adapter indicates that the power is on.

The **Assc** (associate) light indicates that the adapter is active.

Now, your network looks like this:

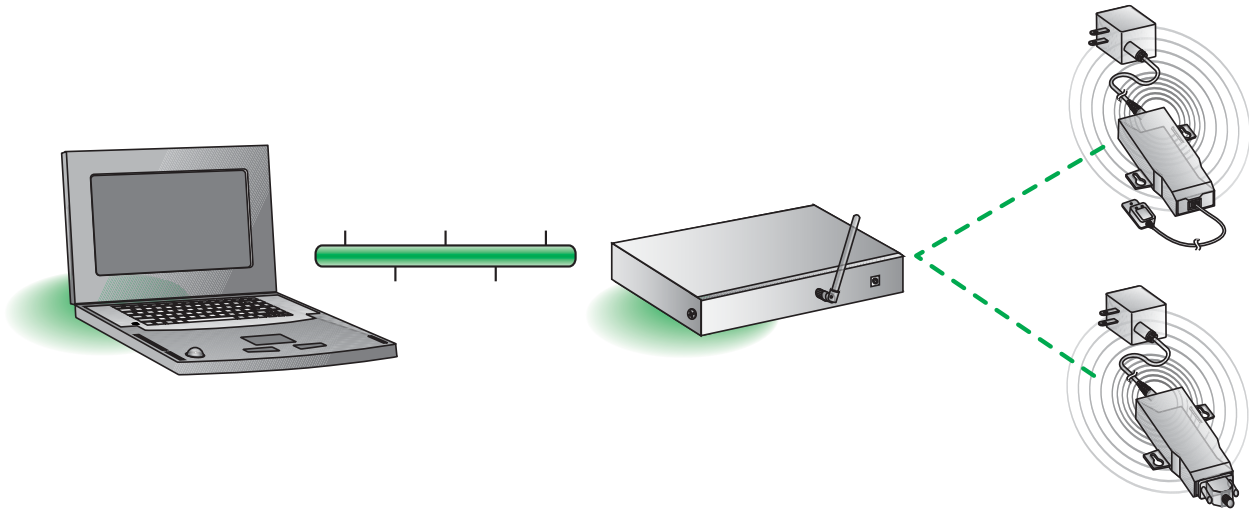

1. Start the Drop-in Network

Access the gateway's web interface

Once the core Drop-in Network components are connected and powered on, open the web interface of the ConnectPort X gateway.

1. On the PC, open a web browser such as Internet Explorer.
2. In the browser's address bar, enter **192.168.1.1** which is the default IP address for the gateway.
3. The home page of the gateway's web interface is displayed.

ConnectPort X8 Configuration and Management

Home

Configuration
Network
Mobile
Mesh Network
Serial Ports
Camera
Alarms
System
Remote Management
Security

Applications
Python

Management
Serial Ports
Connections
Event Logging
Network Services

Administration
File Management
X.509 Certificate/Key Management
Backup/Restore
Update Firmware
Factory Default Settings
System Information
Reboot

Logout

Home

Getting Started

Tutorial Not sure what to do next? This Tutorial can help.

System Summary

Model:	ConnectPort X8
Ethernet MAC Address:	00:40:9D:32:7E:0C
Ethernet IP Address:	192.168.1.1
Mobile IP Address:	Not Connected
Description:	None
Contact:	None
Location:	None
Device ID:	00000000-00000000-00409DFF-FF327E0C

Copyright © 1996-2007 Digi International Inc. All rights reserved.
www.digi.com

Find the XBee Adapters in the Drop-in Network

Next, find the XBee Adapters in the Drop-in Network. In this task, you will view the adapters and gateway from the gateway's web interface.

1. In the gateway's web interface, select **Administration > System Information** from the menu.

Administration

- File Management
- X.509 Certificate/Key Management
- Backup/Restore
- Update Firmware
- Factory Default Settings
- System Information**
- Reboot

The **System Information** page is displayed.

2. From the list of **System Information** links, click **Mesh Network** or **WPAN**, depending on how the link is labeled for the gateway.

System Information

▼ General

Model:	ConnectPort X8
Ethernet MAC Address:	00:40:9D:32:7E:0C
Firmware Version:	2.7.0.16 (Version 82001115_C2 01/31/2008)
Boot Version:	1.1.3 (release_82001113_C)
POST Version:	1.1.3 (release_82001114_C)
CPU Utilization:	2%
Up Time:	4 days 42 minutes 34 seconds
Total Memory:	16384 KB
Used Memory:	11342 KB
Free Memory:	5042 KB

Refresh

- ▶ Serial
- ▶ Network
- ▶ Mobile
- ▶ Mesh Network**
- ▶ Diagnostics

1

1. Start the Drop-in Network

The **Mesh Network/WPAN** page is displayed. It shows several settings for the gateway, followed by a list of the nodes. In the **Node Type** column, the gateway is listed as **coordinator** and two adapters are listed as **end nodes**.

Network View of the Mesh Devices			
Node ID	Network Address	Extended Address	Node Type
[0000]!	[0000]!	00:13:a2:00:40:00:96:14!	coordinator
[0000]!	[0000]!	00:13:a2:00:40:52:49:bb!	end node
[0000]!	[0000]!	00:13:a2:00:40:00:96:27!	end node

Clear list before device discovery

Discover Mesh Devices

Here is how the values in the **Type** column are assigned in the network.

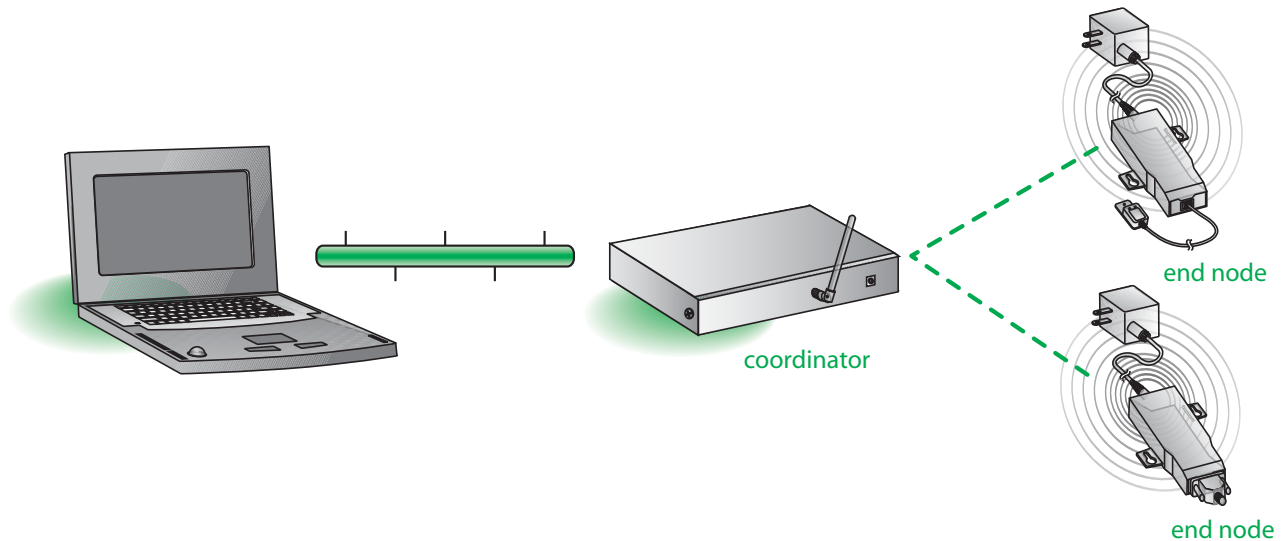

3. To refresh the view, click the **Discover Mesh Nodes** button.

Optional: Assign names to Drop-in Network devices

Descriptive, user-friendly names can be assigned to each Drop-in Networking device, making it possible to reference the units by names rather than their physical addresses. For example, you could name the gateway **gateway**, the XBee Sensor Adapter **sensor**, the XBee RS-232 Adapter **rs232**, or any other names of your choice.

1. In the web interface, go to **Configuration > Mesh Network** or **WPAN**, depending on how the link is labeled for the gateway.

The **Mesh Network/WPAN Configuration** page is displayed.

The screenshot shows the 'Mesh Network Configuration' page. On the left is a navigation menu with 'Mesh Network' selected. The main content area is titled 'Mesh Network Configuration' and contains a section 'Network View of the Mesh Devices'. Below this is a table with the following data:

Node ID	Network Address	Extended Address	Node Type
[0000]!	[0000]!	00:13:a2:00:40:00:96:14!	coordinator
[0000]!	[0000]!	00:13:a2:00:40:52:49:bb!	end node
[0000]!	[0000]!	00:13:a2:00:40:00:96:27!	end node

Below the table is a checkbox labeled 'Clear list before performing refresh' and a 'Refresh' button.

2. From the list under **Network View of the Mesh Devices/Nodes**, select one of the devices by clicking on its network or physical address. Match the physical units with the nodes listed in the **Network View of Mesh Devices/Nodes**, by locating each adapter's 64-bit address. This address is printed on a label on the bottom of the adapter.

The **Mesh Network/WPAN Configuration** page for the selected node is displayed.

The screenshot shows the 'Mesh Network Configuration' page for a selected node. The page is titled 'Mesh Network Configuration' and has a section 'Basic Radio Settings' with the following fields:

- PAN ID: hex (0-FFFF,FFFF=any PAN ID)
- Node Identifier:
- Scan Channels: hex (1FFE=all channels)
- Scan Duration: (0-7)

Below this is a section 'Advanced Radio Settings' with the following fields:

- Transmit Power Level: (dropdown menu)
- CCA Threshold: -dBm (36-80)
- Random Delay Slots: (0-3, 0=disabled)

At the bottom are 'Apply' and 'Cancel' buttons.

1. Start the Drop-in Network

3. Under **Basic Radio Settings**, in the **Node Identifier** setting, enter a name of up to 20 characters.

For example, to assign the node identifier of **gateway** to the XBee module in the gateway, enter:

Mesh Network Configuration

Basic Radio Settings

PAN ID: hex (0-FFFF,FFFF=any PAN ID)

Node Identifier:

Scan Channels: hex (1FFE=all channels)

Scan Duration: (0-7)

Advanced Radio Settings

Transmit Power Level: ▼

CCA Threshold: -dBm (36-80)

Random Delay Slots: (0-3, 0=disabled)



The gateway, adapters, and interface boards in the Drop-in Networking Starter Kit are shipped with the same factory default PAN ID of **3222**.

4. When done entering the Node Identifier, click **Apply**.
5. To name more nodes, go to **Configuration > Mesh Network** or **WPAN**, select another node, and repeat steps 3 and 4.

6. To view the names you assigned to the nodes, go to **Configuration > Mesh Network** or **WPAN** and click **Refresh**. The new names are displayed in the **Node ID** column.

Mesh Network Configuration			
Network View of the Mesh Devices			
Node ID	Network Address	Extended Address	Node Type
gateway	[0000]!	00:13:a2:00:40:00:96:14!	coordinator
rs232	[0000]!	00:13:a2:00:40:00:96:27!	end node
sensor	[0000]!	00:13:a2:00:40:52:49:bb!	end node

Clear list before performing refresh

Refresh

The diagram shows your Drop-in Network with the names you assigned.

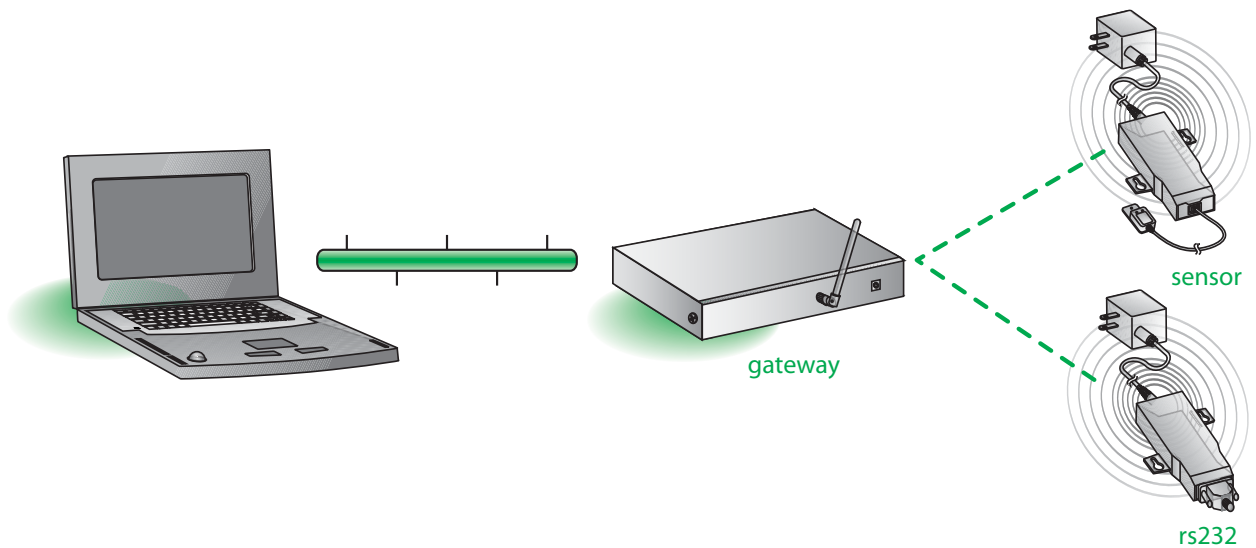

1

1. Start the Drop-in Network

Install and run the demo application

The Starter Kit includes a demo application to be installed and run on the host PC. It demonstrates how you can send and receive data between your PC, and devices in your WPAN and Ethernet network.

Install

1. Insert the **Hardware & Software Setup** in the CD/DVD drive of the PC. The Drop-in Networks Starter Kit splash page is displayed.
2. In the list of options on the right side of the screen, click **Install Demo Application**.

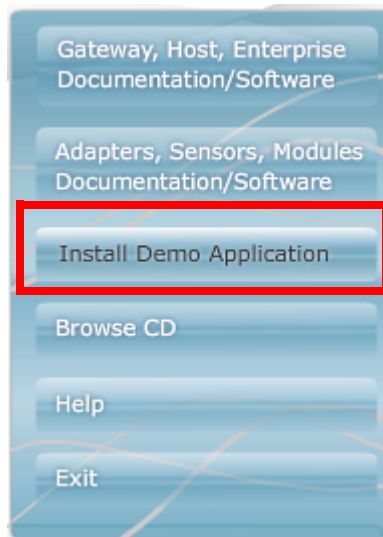

3. The **Digi Drop-in Networking Setup** wizard is launched. Follow the prompts in the wizard, choosing to install the demo application in the default location.

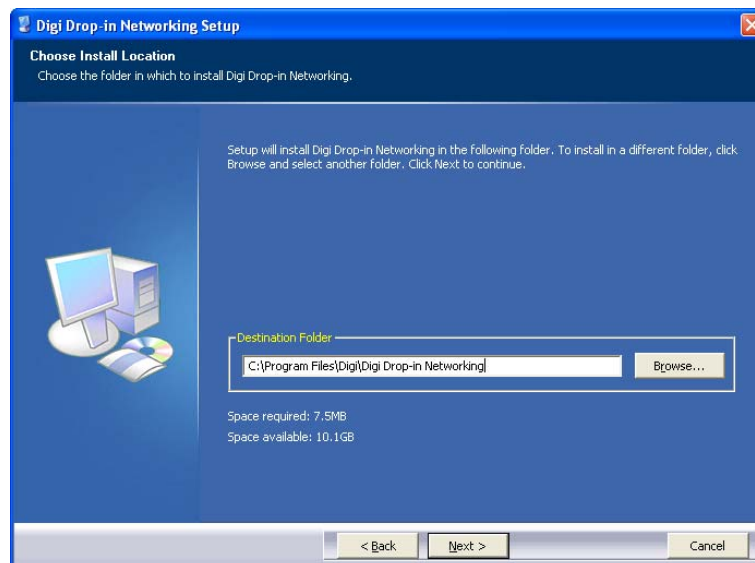

4. Click **Finish** to complete the wizard.

By default, the sample PC application is launched automatically. When prompted, accept the default IP address of **192.168.1.1** and click **OK**.

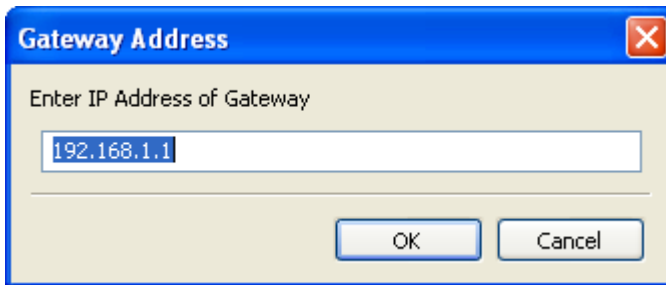

The demo application is now installed on your PC.

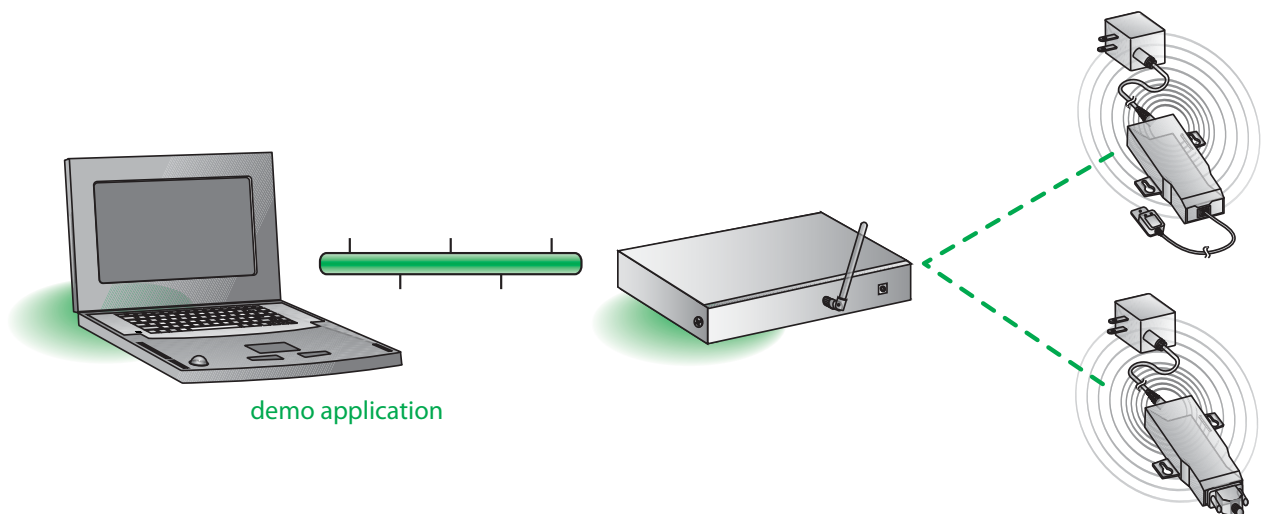

Search for and display nodes

First, the demo application searches for any nodes in the range of the gateway. A progress dialog is displayed during this function.

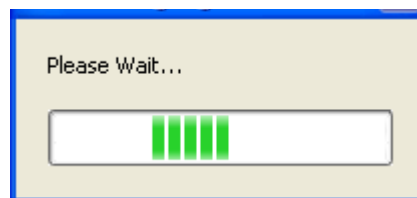

1. Start the Drop-in Network

Read the temperature from the temperature sensor

Any nodes found report information back to the demo application on the PC through the gateway. The information read by these nodes is displayed in the demo application window.

To exercise the temperature-sensing function, the demo application reads the temperature from the Watchport/T temperature sensor connected to the XBee Sensor Adapter. A progress dialog is displayed.

If there were more XBee Sensor Adapters connected to the Drop-in Network, the demo application would display the temperature read by any sensors attached to any XBee Sensor Adapters in the range of the gateway.



Additional XBee Sensor Adapters and Watchport Sensors can be purchased at the Digi online store at www.digi.com

Display the temperature

The results are displayed in the demo application window in degrees Celsius and Fahrenheit.

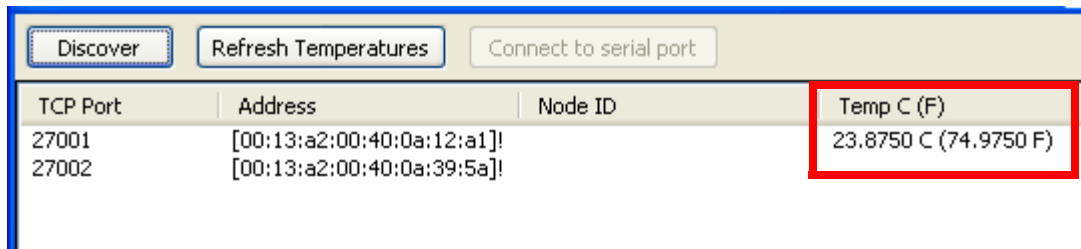

TCP Port	Address	Node ID	Temp C (F)
27001	[00:13:a2:00:40:0a:12:a1]!		23.8750 C (74.9750 F)
27002	[00:13:a2:00:40:0a:39:5a]!		

Refresh the temperature display

To refresh the display of temperatures, click the **Refresh Temperatures** button.

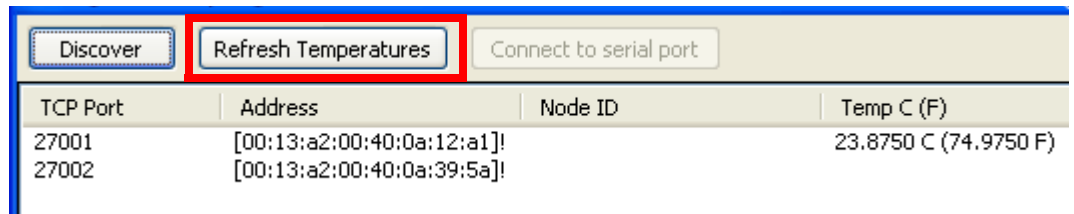

TCP Port	Address	Node ID	Temp C (F)
27001	[00:13:a2:00:40:0a:12:a1]!		23.8750 C (74.9750 F)
27002	[00:13:a2:00:40:0a:39:5a]!		

The diagram shows which part of your Drop-in Network is sending information back to your PC.

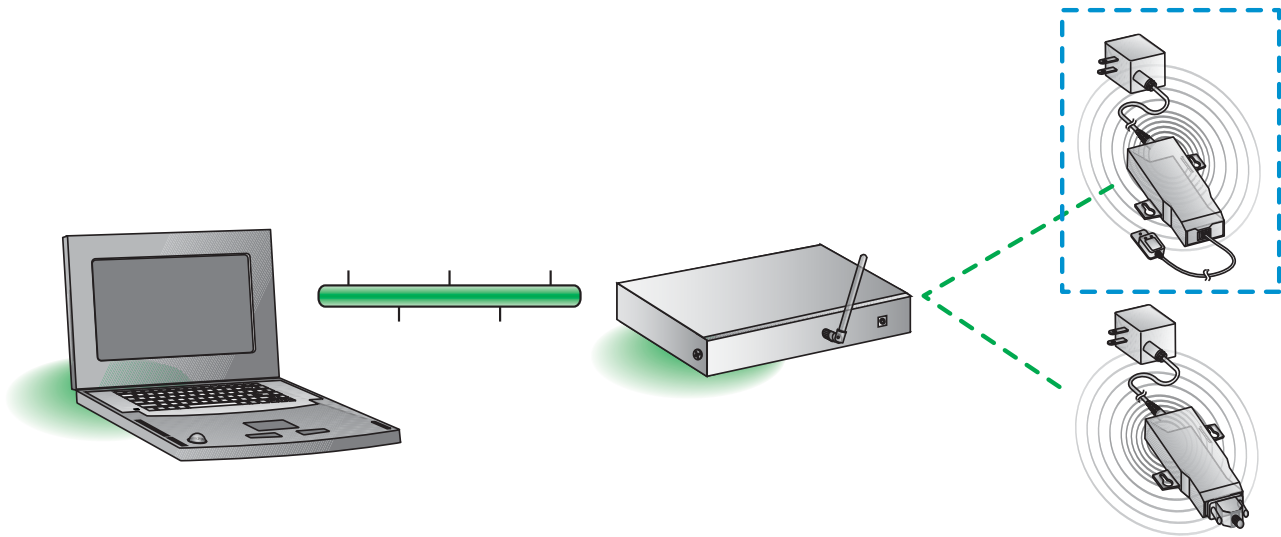

Exercise the terminal function

Next, exercise the demo application's terminal function. This function shows how data can be sent and received between WPAN and Ethernet networks.

1. In the demo application window, select the RS-232 Adapter, and click the **Connect to serial port** button.

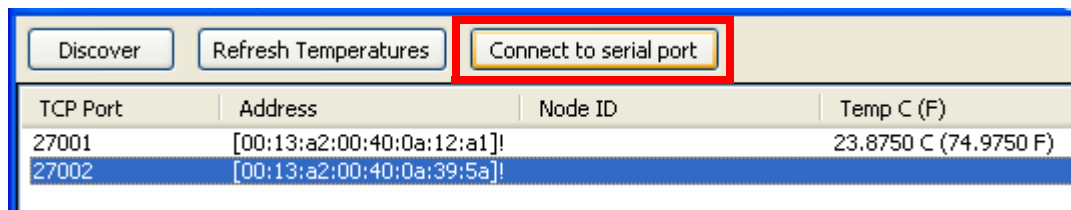

2. A terminal emulator window is displayed.

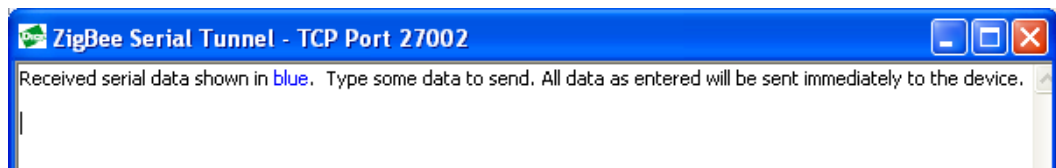

1. Start the Drop-in Network

3. In the terminal emulator window, type some text, for example, **hello world**. The text is sent to the XBee RS-232 Adapter with the loopback plug attached, and returned to the host PC. The text transmitted to the adapter is displayed in black. The text returned from the adapter is displayed in blue.

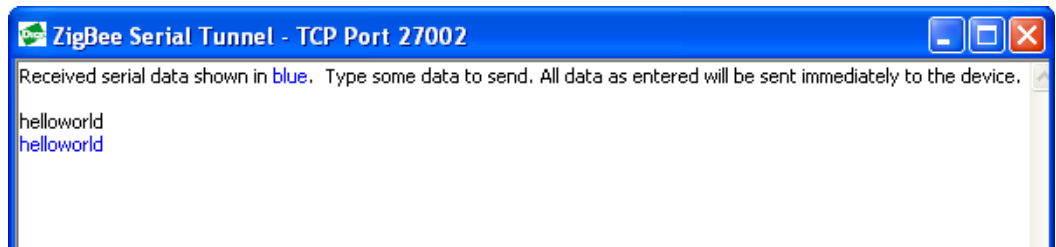

The diagram shows which parts of your network are sending and receiving data.

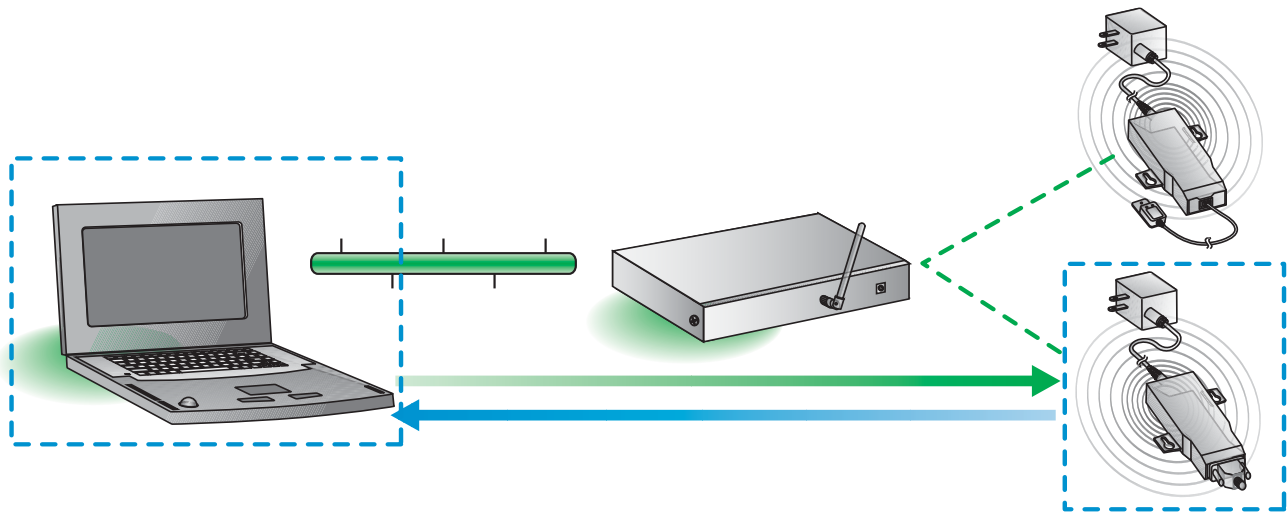

4. Remove the loopback plug from the XBee RS-232 Adapter.
5. In the terminal emulator window, type some text again. Note how only black text is displayed, because no text is being returned from the XBee RS-232 Adapter.

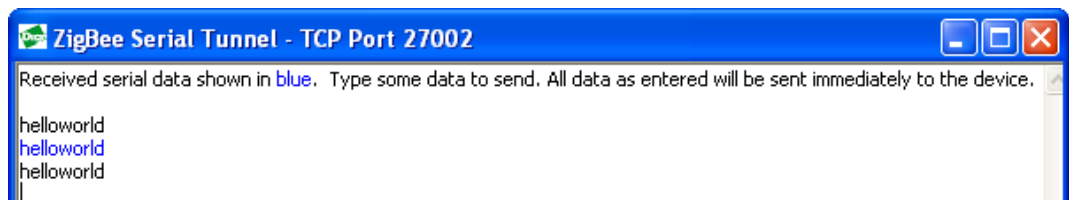

6. Close the terminal emulator window.

How did this demo application work?

The demo application you just ran uses Python programming language functions to do several things.

First, it discovers the XBee Adapters, known in the WPAN as nodes.

Next, it assigns a TCP port to each node. This assignment is the key link between the WPAN and Ethernet networks, and allows the demo application to communicate with each node over the Ethernet network. In the demo application window, note the numbers assigned to each node in the **TCP Port** column.

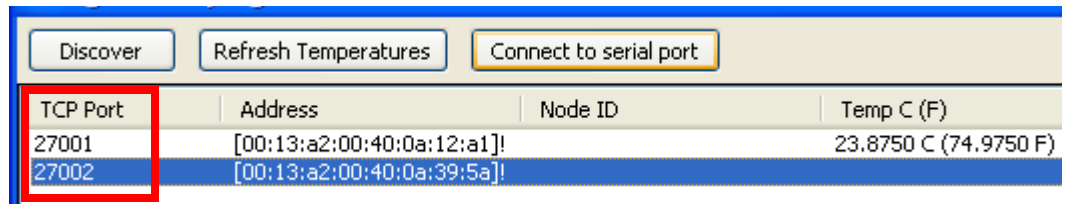

TCP Port	Address	Node ID	Temp C (F)
27001	[00:13:a2:00:40:0a:12:a1]!		23.8750 C (74.9750 F)
27002	[00:13:a2:00:40:0a:39:5a]!		

Next, the demo application uses Python functions to read temperature data from the Watchport/T sensor connected to the XBee Sensor Adapter.

When you click **Connect to serial port** button, additional Python functions send and receive data between the PC and the XBee RS-232 Adapter. Note how the TCP port number assigned to the RS-232 adapter is displayed in the title bar:

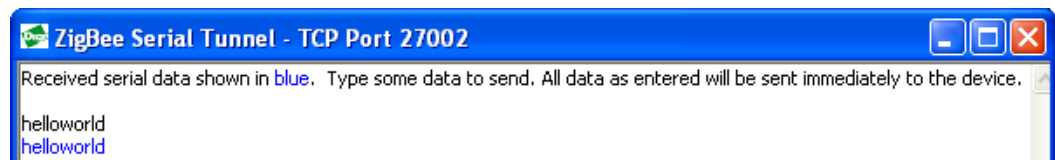

Want to learn more?

You can use the demo application as a base for embedded application development, which the next section introduces. To learn more right now, go to these places:

To	Go to
Launch the demo application again	Start > Programs > Digi > Digi Drop-in Networking > Digi Gateway ZigBee Viewer Sample
View the source for the demo application	Start > Digi > Drop-in Networking > Samples
Learn about the Python functions in the demo application	Start > Digi > Drop-in Networking > Documentation > Digi Python Programmers Guide
Get information about the XBee modules in the XBee Adapters	The XBee module product manual, on the Hardware & Software Setup

1. Start the Drop-in Network

Congratulations!

You have successfully installed a Drop-in Network and exercised the functions of the demo application.

To further explore the potential of Drop-in Networking, go the next section.

1

2. Extend the Drop-in Network with Embedded Development

The Drop-in Networking Starter Kit includes XBee interface boards and modules, hardware accessories, software, and documentation to further explore embedding a wireless networking solution into your specific application.

OBJECTIVES

- Add XBee interface boards to your Drop-in Network
- Configure the XBee module on the battery-powered XBee interface board for low-power operation
- Use embedded development tools and documentation

Connect and power on interface boards

There are two XBee interface boards, one powered by batteries and the other through an external AC power supply.



Additional interface boards and XBee modules are available at:
<http://www.digi.com/din>

XBee interface board, AC-powered

1. Open and unpack the box labeled **XBee Interface Board (AC)**.
2. Connect the XBee module to the connectors on the interface board. Orient the board and connector pins as shown in the diagram.
3. Connect the RS-232 cable to the serial port on the interface board, and to the PC's serial COM port.
4. Connect the power supply to the interface board.

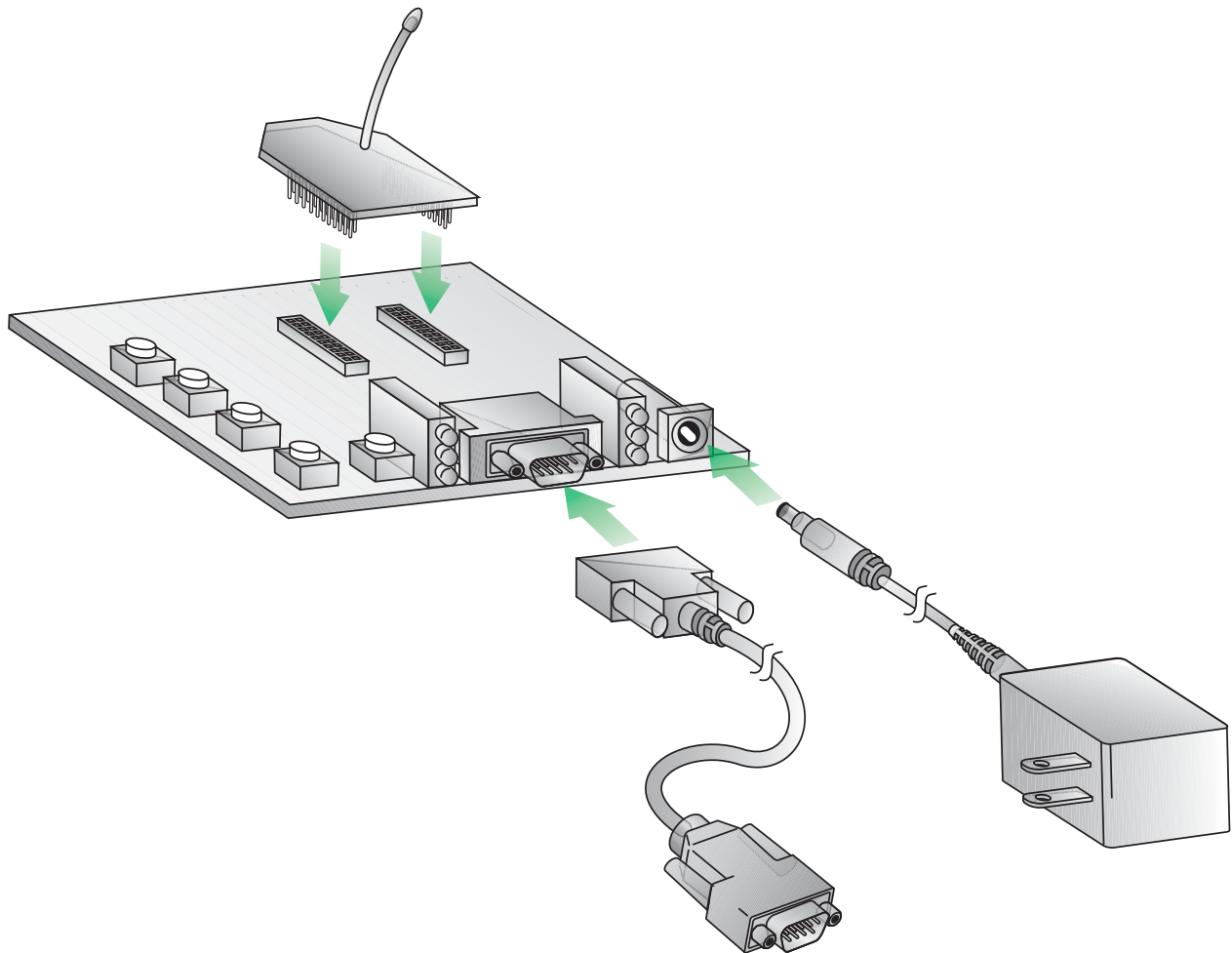

XBee interface board, battery-powered

1. Open and unpack the box labeled **XBee Interface Board (Batt)**.
2. Connect the XBee module to the connectors on the interface board.
3. Connect the RS-232 cable to the serial port on the interface board, and to the PC's serial COM port.
4. Connect the battery to the terminals on the battery cable.
5. Connect the battery cable to the power port of the interface board.
6. Because the interface board is battery-powered, the XBee module must be set to low-power mode. Go to "Configure low-power mode for battery-powered interface board" on page 34 for instructions.

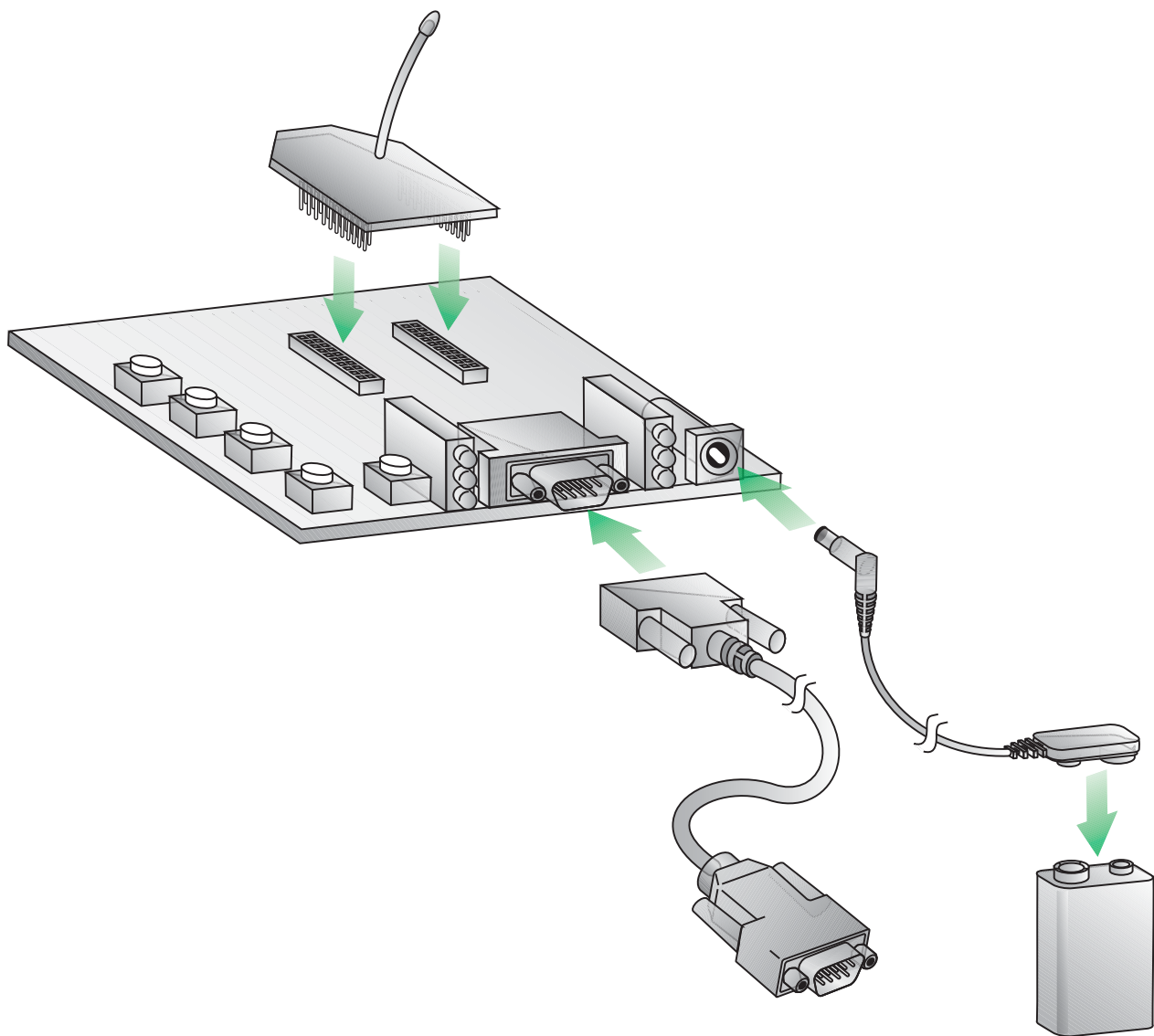

LEDs and buttons

The XBee interface boards have several LEDs to the right and left of the RS-232 connector that indicate network activity and signal strength, plus several buttons.

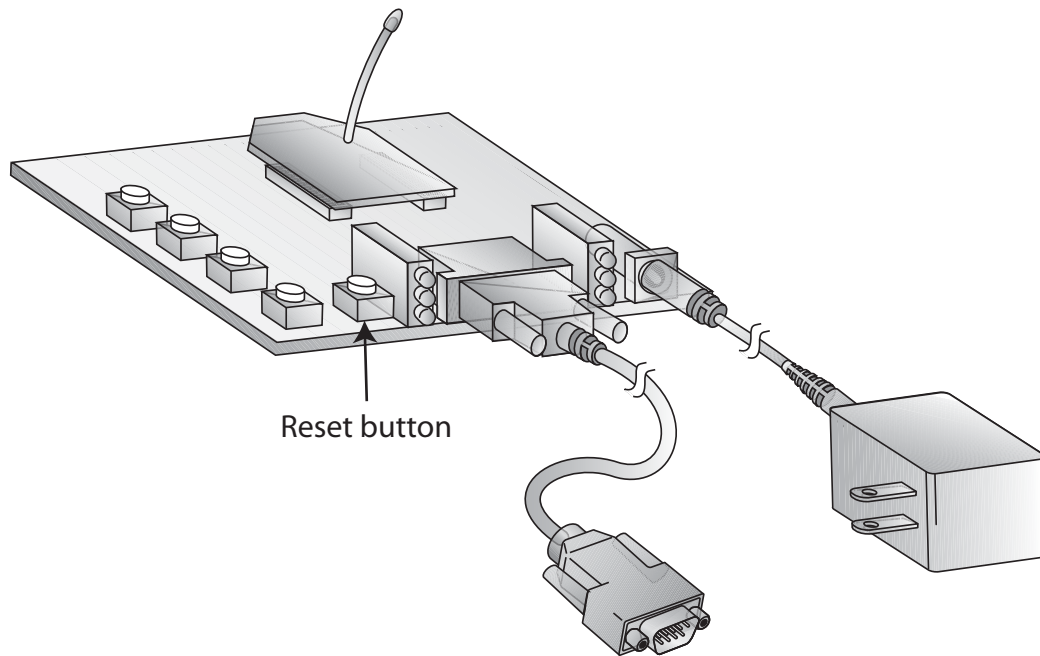
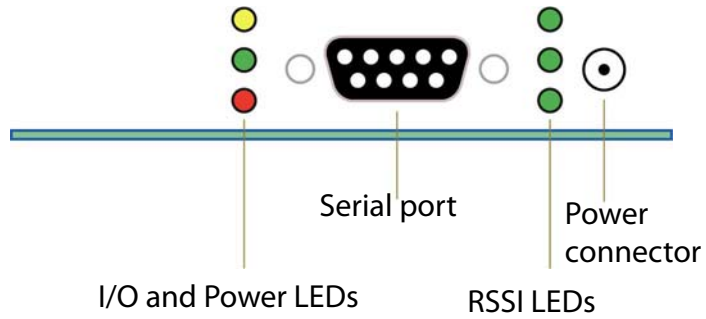

2

Now, your Drop-in Network looks like this:

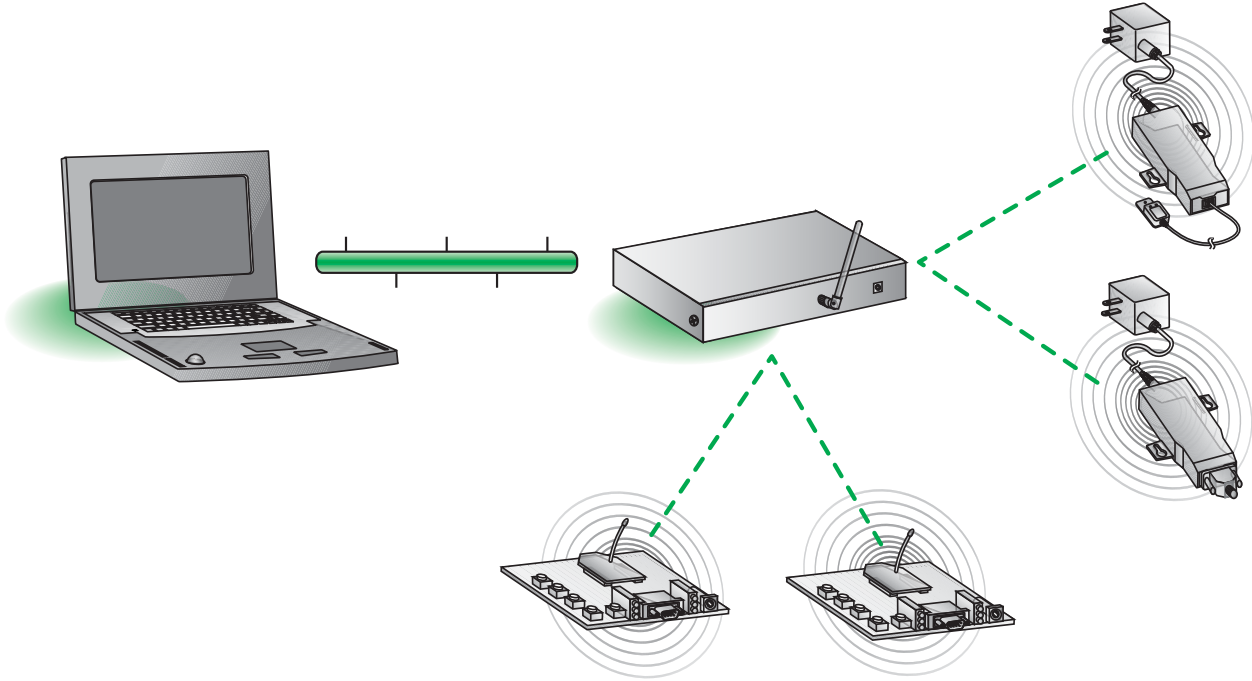

Configure low-power mode for battery-powered interface board

By default, all XBee modules are set to Sleep Mode = 0 (No Sleep). With this setting, a typical Alkaline 9V battery will power the module for less than a day. The XBee module on the battery-powered XBee interface board must be configured to low-power mode before using the board. This procedure requires installing configuration and management software for RF modules called X-CTU on your PC, and configuring several settings.

Install X-CTU software

1. Insert the **Hardware & Software Setup** in the PC's CD/DVD drive.
2. On the Home page, click **Adapters, Sensors, Modules Documentation/Software**
3. Click **XBee 802.15.4Module**.
4. Click **Install X-CTU**.

Start X-CTU and establish communication with XBee interface board

1. Select **Start > Programs > Digi > X-CTU**. The X-CTU Software interface is opened. The interface has several tabs:
 - **PC Settings:** Sets up PC serial COM ports to interface with the XBee module.
 - **Range Test:** Tests the range of wireless links under varying conditions.
 - **Terminal:** Reads and sets communications parameters on the XBee module and monitors data communications.
 - **Modem Configuration:** Reads and sets configuration parameters on the XBee module.

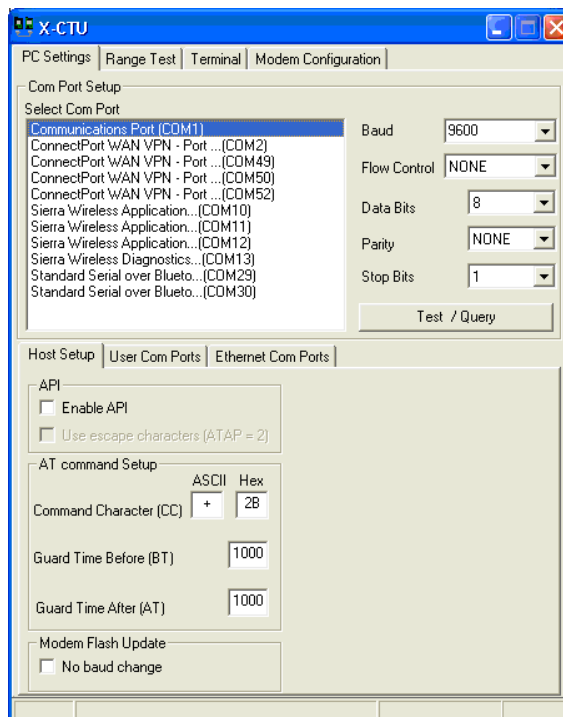

2. On the **PC Settings** tab, establish communications between the PC and interface board:
 - Select **COM 1**.
 - Click the **Test/Query** button.

Note: If the message **Failure to enter AT Command Mode** is displayed, this failure is most commonly caused by a baud rate mismatch. Make sure the **Baud** setting on the **PC Settings** tab matches the interface data rate of the module. The interface data rate is set by the BD parameter; its default setting is 9600 bps.

Program the XBee module to low-power sleep mode

To reconfigure the XBee module to Low Power mode:

1. In X-CTU, click the **Modem Configuration** tab.
2. Click the **Read** button.

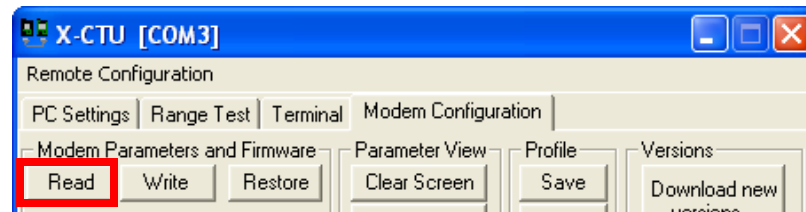

3. The parameters and settings for the XBee module on the interface board are read and displayed. Scroll down to the **Sleep Modes** settings.

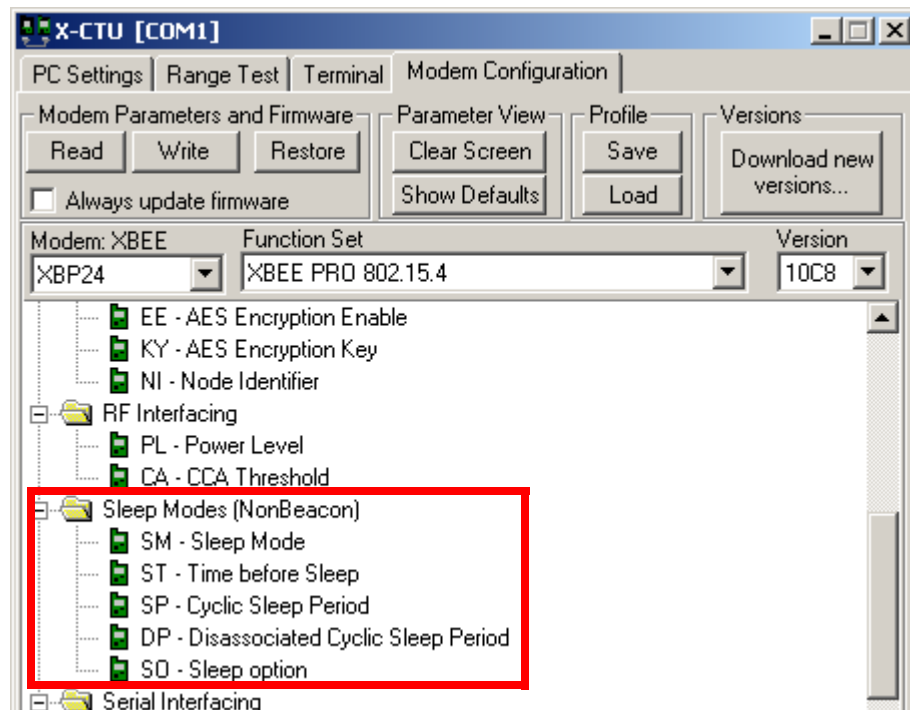

4. Set the Sleep Mode settings for the XBee module as follows:
 - **SM - Sleep Mode:** Set to **4 – Cyclic Sleep**. This setting causes the XBee module to sleep in a period of time (ST) following the last data transmission, and wake up following the Cyclic Sleep Period (SP).
 - **ST - Time before Sleep:** Set to **1388**.
1388 (hex) = 5000 (dec) X 1ms = 5000 ms = 5 seconds
 - **SP - Cyclic Sleep Period:** Set to **7d0**
7d0 (hex) = 2000 (dec) x 10ms = 20000 ms = 20 seconds
5. To write these settings to the XBee module, click the **Write** button.
6. Sleeping end devices can only communicate with a sleep coordinator. Designate one non-sleeping node as the sleep coordinator by setting its CE parameter to **1**. The sleep coordinator must also have its SP parameter set to **7d0**. The sleep coordinator will then use appropriate timeouts and delays when communicating with the sleeping node.

Verify XBee interface board operation

To confirm proper operation of the XBee interface board after configuring sleep-mode settings:

1. Select **Start > Programs > Digi > Digi Drop-in Networking > Digi Gateway ZigBee Viewer Sample** to launch the demo application and re-discover the nodes.
2. Open the web interface for the gateway.
3. Go to **Administration > System Information > Mesh Network** or **WPAN**, depending on how the link is labeled for the gateway. The **Network View of Nodes** page should display a new device, assigned to a TCP Port.
4. To test the operation of this device as it enters and exits sleep mode, attach the red loopback plug in the **Accessories** box to the battery-powered XBee interface board. As the XBee module enters sleep mode, the red Associate/Power LED turns off. When it exits sleep mode, the Associate/Power LED turns on again.

Embedded development resources

Several software and documentation resources and additional Digi products are available to help you in embedded development efforts.

Software

Drop-in Networking program group

The Drop-in Networking program group was added during installation of the sample PC application. To view this program group, select **Start > Programs > Digi > Digi Drop-in Networking**.

To run the demo application again, select **Digi Gateway ZigBee Viewer Sample**.



Demo application source code

The demo application is developed in the Python[®] programming language and can be used as an example and base for further application development. To view the source code for the demo application, go to **Start > Programs > Digi > Digi Drop-in Networking > Samples**.

Documentation and help

There are several places to learn more about Drop-in Networking products and embedded development programming:

- Go to **Digi Drop-in Networking > Documentation** for documents helpful in embedded development that have been loaded on your PC.
- Browse the **Hardware & Software Setup** for additional detailed manuals for Drop-in Networking Starter Kit components.
- See Digi's Drop-in Networking Documentation page at: www.digi.com/din/docs/

XBee module documentation

The **Hardware & Software Setup** has product manuals and data sheets for the XBee modules in the gateway, XBee Adapters, and XBee interface boards. Click **Adapters, Sensors, Modules Documentation/Software** to browse these documents. The product manuals describe module features, modes of operation, and commands for controlling the modules, and reading data to/writing data from them.

Digi Python Programming Guide

The Drop in Networking Starter Kit includes two demo applications: the PC-based demo application you just ran, and an application on the gateway that discovers the nodes.

These applications are written in the Python programming language, and serve as an example for Drop-in Networking application development.

Python is a dynamic, object-oriented language for developing software applications, from simple programs to complex embedded applications. It includes extensive libraries and works well with other languages. A true open-source language, Python runs on a wide range of operating systems.

The *Python Programming Guide* introduces the Python programming language by showing how to create and run a simple Python program. It reviews Python modules, particularly those modules with Digi-specific behavior, and the functions used in the sample PC and gateway applications. It describes how to load and run Python programs onto Digi devices, either through the command-line or web user interfaces, and how to run several sample Python programs.

Python Support Forum

Visit Digi International's Python Support Forum at:

<http://www.digi.com/support/forum/forum.jspa?forumID=104>

In this forum, you can view sample programs, ask questions, and share Python programming information and solutions with other Python developers.

ConnectPort X Family User's Guide

The *ConnectPort X User's Guide* provides information about the features and functions the ConnectPort X gateway, including how to configure, monitor, and administer the gateway, primarily from its web user interface.

XBee Adapter, Sensor, and Router documentation

Additional information on the XBee Adapters, including detailed descriptions of LEDs, buttons, and pinouts, is available in the *XBee Adapters, Routers, and Sensors User's Guide*. Download this document from:

www.digi.com/din/docs/

Order additional Drop-in Networking products



To learn more about and order other Drop-in Networking products, browse the Hardware & Software Setup and go to Digi's Drop-in Networking page at

www.digi.com/din/

Examples of embedded development efforts

Here are descriptions ways you can extend your Drop-in Network through embedded development, from simple programming efforts to larger-scale ones.

Modify the PC demo application

The PC and gateway demo applications can be modified. See the readme files and source code for both applications for information on how the applications run and the steps involved.

The gateway has a function to upload and manage Python program files on the gateway, and to automatically execute the Python programs at gateway startup. In the gateway web interface, go to **Applications > Python**.

Create new applications

Custom applications can be written and loaded onto the XBee interface boards.

The core processors are specific to WPAN communications; product information is available in MaxStream documents included on the Hardware & Software Setup.

Exercise serial connections

Some ways to further exercise the Drop-in Network's Starter Kit's serial connections include:

- Connect more serial devices and communicate with them.
- Modify the demo applications; for example, change several steps of the application that exercise serial connection.
- Write and run a custom Python application for communicating with serial devices.

Experiment with additional sensors

The XBee Sensor Adapter can be used with additional sensor types. For example:

- The Watchport/H Humidity / Temperature Sensor is a humidity sensor that measures relative humidity, true humidity and temperature.
- The Watchport/D Distance Sensor is a distance sensor that measures via infrared a distance of 20 cm to 150 cm.
- The Watchport/A Acceleration/Tilt Sensor is an accelerometer that measures position in a x-y, pitch, and roll form.



For additional information and to order these sensors, go to:
<http://www.digi.com/din>

2. Extend the Drop-in Network with Embedded Development

2

Plan, deploy, and manage Drop-in Networks

Use Digi planning, commissioning, and deployment tools

Creating network plans is useful when your networks is fairly large or you need to commission and manage many networks. The **Network Planner** is a tool that helps a network designer define the topology and characteristics of a network. It creates a network plan, also known as a manifest, that the Commissioner tool uses to easily commission a wireless network.

The **Commissioner** tool allows an installer to commission, or install, physical devices on a wireless network. Once the network plan is created, it can be imported into the Commissioner and commissioning begins. Alternatively the Commissioner can be used without a network plan to perform ad-hoc commissioning of devices.

When commissioning devices, the commissioning tool updates the network plan with the actual physical address of each logical device in the network plan. This updated network plan can then be used by other tools and devices, including the Network Planner, the gateway, and Connectware Manager.

The Commissioner has a user-friendly interface and is available in Windows (Java) and PDA (Windows Mobile) versions. For more information and to order these tools, go to www.digi.com/din.

Use Connectware Manager

Digi Connectware Manager is a device management platform that provides remote network management of all connected hardware, including devices on a WPAN. In contrast to the one-user-to-one-device model of other Digi device interfaces, Digi Connectware Manager deploys a one-user-to-many-devices interface model. From Digi Connectware Manager, you can provision and configure network hardware, track device performance, remotely set filters and alarms, monitor connections, reboot devices and reset defaults, and remotely upgrade firmware. Extensions to Digi Connectware Manager make it a particularly attractive platform for managing WPAN devices behind the gateway. It displays all nodes on the WPAN with the ability to query for node profiles, node descriptors, connected endpoints, radio configuration settings, radio statistics, bindings, and more.

This kit includes a 30-day trial offer for a live demonstration version of Digi Connectware Manager. In addition, the Hardware and Software Setup CD includes a copy of Digi Connectware Manager that can be installed on your PC.

Digi Connectware Manager has several network views that are particularly useful for viewing and configuring WPANs: the Mesh/WPAN View and detailed views of nodes.

Mesh Networks/WPAN view

The **Mesh/WPAN** device management view of Digi Connectware Manager allows for displaying devices in their WPAN, including their node ID, the network to which they belong, physical addresses, their role in the WPAN (end node). (The example below is for a ZigBee network; for an 802.15.4 network, the **Type** column would display coordinators and end nodes.)

The screenshot displays the Connectware Device Management software interface. The main window shows a 'Mesh Networks' view. The title bar reads 'Connectware Device Management - 10.8.128.24'. The menu bar includes 'File', 'View', 'Device', 'Group', 'Mesh', and 'Help'. The toolbar contains icons for 'IP Networks' and 'Mesh Networks'. The main display area is divided into two sections:

Mesh Gateways - All Devices - Filtered

Device ID	Device Type	PAN ID	IP Address	Host Name	Connection Status	Last Use	Description
00000000-00000000-00409DFF-FF298D0B	ConnectPort W/WAN	0x234	10.8.16.32		Disconnected	7/19/07 9:54:44 AM CDT	

Mesh Network - Gateway: 00:13:a2:00:40:0a:06:7d!, PAN ID: 0x234

Node ID	Network Address	Physical Address	Type	Parent	Status
coordinator	0x0	00:13:a2:00:40:0a:06:7d!	coordinator	0xffff	ok
xyz	0x2e5f	00:13:a2:00:40:0a:06:6e!	router	0xffff	ok
	0x9936	00:13:a2:00:40:0a:06:d8!	router	0xffff	ok

At the bottom of the window, there is a 'Messages' section and a status bar that reads 'Ready' and 'Mesh Nodes (0 of 3 selected)'.

Detailed node views

From the **Mesh/WPAN** view, more detailed views of nodes can be accessed. For example, here are the **Radio** and **Summary** tabs of the **Device Properties** view for a particular node:

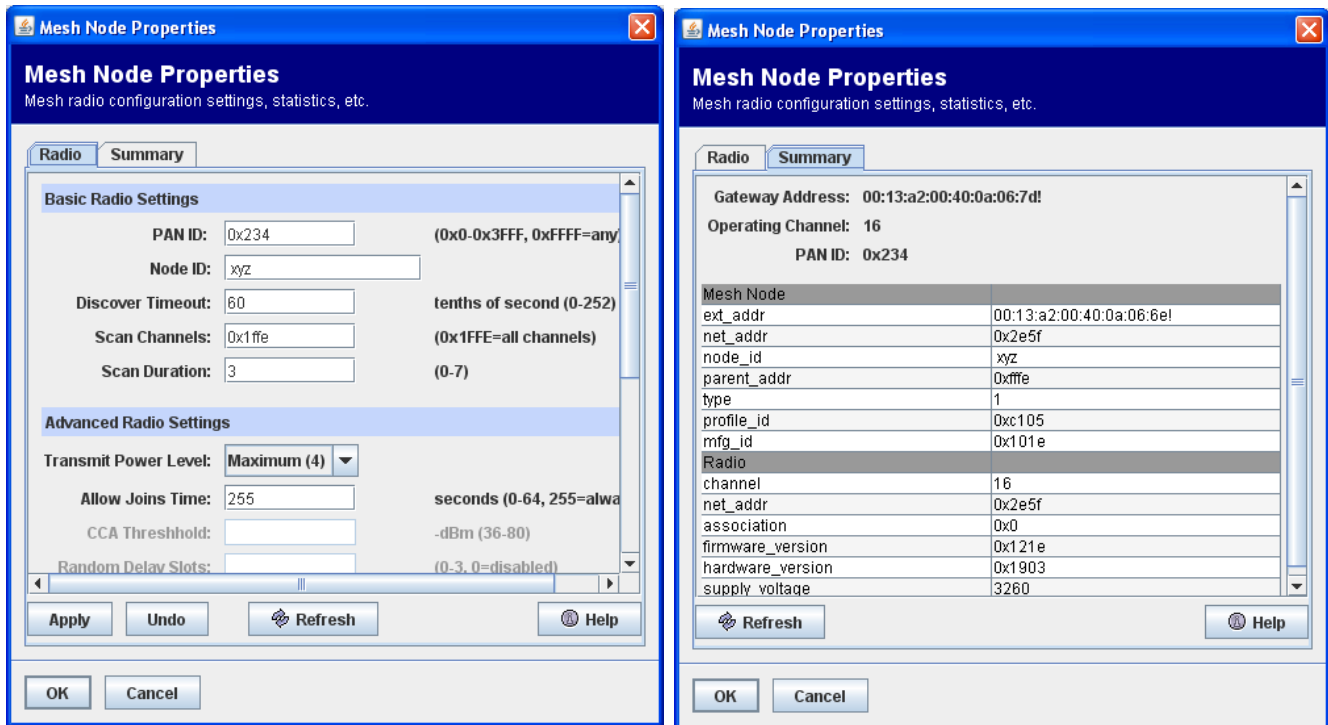

Digi Connectware Manager product information

For more information about Digi Connectware Manager, see the *Connectware Manager Getting Started Guide* on the Hardware and Software Setup CD.



PN:(1P) 9000996-88 A