



Test Report issued under the responsibility of:



**TEST REPORT
IEC 62368-1**

**Audio/video, information and communication technology equipment
Part 1: Safety requirements**

Report Number : 151101267SHA-001
Date of issue : 2015-12-01
Total number of pages : 113 pages

Applicant's name : GlobTek, Inc.
Address : 186 Veterans Dr. Northvale, NJ 07647 USA

Test specification:
Standard..... : IEC 62368-1:2014 (Second Edition)
Test procedure..... : CB Scheme
Non-standard test method : N/A

Test Report Form No. : IEC62368_1B
Test Report Form(s) Originator..... : UL(US)
Master TRF : 2014-03

Copyright © 2014 Worldwide System for Conformity Testing and Certification of Electrotechnical Equipment and Components (IECEE), Geneva, Switzerland. All rights reserved.
This publication may be reproduced in whole or in part for non-commercial purposes as long as the IECEE is acknowledged as copyright owner and source of the material. IECEE takes no responsibility for and will not assume liability for damages resulting from the reader's interpretation of the reproduced material due to its placement and context.
If this Test Report Form is used by non-IECEE members, the IECEE/IEC logo and the reference to the CB Scheme procedure shall be removed.
This report is not valid as a CB Test Report unless signed by an approved CB Testing Laboratory and appended to a CB Test Certificate issued by an NCB in accordance with IECEE 02.

General disclaimer:
The test results presented in this report relate only to the object tested.
This report shall not be reproduced, except in full, without the written approval of the Issuing CB Testing Laboratory. The authenticity of this Test Report and its contents can be verified by contacting the NCB, responsible for this Test Report.

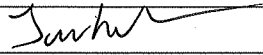
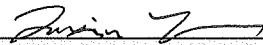
| | | |
|--|--|---|
| Test Item description | ITE Power Supply | |
| Trade Mark |  | |
| Manufacturer | Same as applicant | |
| Model/Type reference | GT*41134*****, GT*96060*****, (Refer to Model Differences table for details) and GT-41134-0606-W2-TAB | |
| Ratings | Input: 100-240V~, 50-60Hz, 0.3A or 0.6A for GT*41134*****, and GT*96060*****; 120V~, 60Hz, 0.3A for GT-41134-0606-W2-TAB Output: Refer to pages 7 and 8 for details | |
| Testing procedure and testing location: | | |
| <input checked="" type="checkbox"/> CB Testing Laboratory: | Intertek Testing Services Shanghai | |
| Testing location/ address | Building No.86, 1198 Qinzhou Road (North), 200233 Shanghai, China | |
| <input type="checkbox"/> Associated CB Testing Laboratory: | | |
| Testing location/ address | | |
| Tested by (name + signature) | Jack Chen |  |
| Approved by (name + signature) | Justin Yu |  |
| Testing procedure: TMP/CTF Stage 1 | | |
| Testing location/ address | | |
| Tested by (name + signature) | | |
| Approved by (name + signature) | | |
| Testing procedure: WMT/CTF Stage 2 | | |
| Testing location/ address | | |
| Tested by (name + signature) | | |
| Witnessed by (name + signature) | | |
| Approved by (name + signature) | | |
| Testing procedure: SMT/CTF Stage 3 or 4 | | |
| Testing location/ address | | |
| Tested by (name + signature) | | |
| Approved by (name + signature) | | |
| Supervised by (name + signature) | | |

| | |
|--|---|
| <p>List of Attachments (including a total number of pages in each attachment):</p> <p>Page 69–78 : Photograph</p> <p>Page 79-84 : National differences for US and Canadian</p> <p>Page 85-113 : Evaluation sheet for plug portion</p> | |
| <p>Summary of testing:</p> <p>From the result of our examination and tests in the submitted samples, conclude they comply with the requirements of the standard IEC 62368-1:2014 (Second Edition) & EN 62368-1:2014.</p> | |
| <p>Tests performed (name of test and test clause):</p> <p>5.2 Classification and limits of electrical energy sources</p> <p>5.4.1.8 Determination of working voltage</p> <p>5.4.1.10.3 Ball pressure test</p> <p>5.4.2 Clearances</p> <p>5.4.3 Creepage distances</p> <p>5.4.8 Humidity conditioning</p> <p>5.4.9 Electric strength test</p> <p>5.7.2.1 Measurement of touch current</p> <p>6.2.2.2 Power measurement for worst-case load fault</p> <p>6.2.2.3 Power measurement for worst-case source fault</p> <p>6.4.3.3 Single Fault Conditions test</p> <p>B.2.5 Input test</p> <p>B.3.5 Maximum load at output terminals</p> <p>F.3.10 Permanence of markings</p> <p>G.5.3.3 Overload test of Transformers</p> <p>T.2 Steady force test, 10 N</p> <p>T.3 Steady force test, 30 N</p> <p>T.4 Steady force test, 100 N</p> <p>T.7 Drop test</p> <p>T.8 Stress relief test</p> | <p>Testing location:</p> <p>Intertek Testing Services Shanghai Building No.86, 1198 Qinzhou Road (North), 200233 Shanghai, China</p> |
| <p>Summary of compliance with National Differences:</p> <p>List of countries addressed</p> <p>The national differences for US and Canadian have been checked according to the standard IEC 62368-1:2014 (Second Edition).</p> <p><input checked="" type="checkbox"/> The product fulfils the requirements of IEC 62368-1:2014 (Second Edition) & EN 62368-1:2014.</p> | |

Copy of marking plate (representative):

The artwork below may be only a draft. The use of certification marks on a product must be authorized by the respective NCBS that own these marks.

GlobTek, Inc. POWER SUPPLY
电源适配器

P/N(料号):
MODEL(型号): GTM41134-0603
INPUT(输入): 100-240~, 50-60Hz, 0.6A
OUTPUT(输出): 3.3V --- 1.8A

GlobTek, Inc.

CAUTION: CE EFFICIENCY LEVEL

Risk of electric shock/Risque de choc électrique
Dry Location use only/Pour Utilisation à l'intérieur

MADE IN CHINA (中国制造) WWYY RoHS

GlobTek

Model: GTM41134-0606-1.0-F

Input: 100-240V~, 50-60Hz, 0.6A

Output: 5V --- , 1.2A

CE

GlobTek® ,Inc.
www.globtek.com
ITE/MEDICAL POWER SUPPLY
CLASS 2 POWER SUPPLY

PART NO(料号):WR91A1000KR9RVBG2723
MODEL(型号):GT-41134-0606-W2-TAB
INPUT(输入):120V~.60Hz, 0.6A
OUTPUT(输出): 6 V  1 A

CE
CQC 
GlobTek, Inc.
VCI





DO NOT REMOVE THE TAG
WARNING /AVERTISSEMENT:
RISK OF ELECTRIC SHOCK
DRY LOCATION USE ONLY
FOR INDOOR USE ONLY
Risque de choc électrique
Utilisation endroit sec
Pour une utilisation en intérieur
See instructions if the input
plug does not fit the power outlet



EFFICIENCY LEVEL 



MADE IN CHINA
RoHS 2
WWYY

| TEST ITEM PARTICULARS: | |
|--|---|
| Classification of use by | <input checked="" type="checkbox"/> Ordinary person <input type="checkbox"/> Instructed person <input type="checkbox"/> Skilled person <input type="checkbox"/> Children likely to be present |
| Supply Connection..... | <input checked="" type="checkbox"/> AC Mains <input type="checkbox"/> DC Mains <input type="checkbox"/> External Circuit - not Mains connected - <input type="checkbox"/> ES1 <input type="checkbox"/> ES2 <input type="checkbox"/> ES3 |
| Supply % Tolerance | <input checked="" type="checkbox"/> +10%/-10% <input type="checkbox"/> +20%/-15% <input type="checkbox"/> +____%/ -____% <input type="checkbox"/> None |
| Supply Connection – Type | <input checked="" type="checkbox"/> pluggable equipment type A - <input type="checkbox"/> non-detachable supply cord <input checked="" type="checkbox"/> appliance coupler (Note: Appliance coupler for one type of open frame model series. Final determination in end product evaluation for other types of open frame model series.) <input checked="" type="checkbox"/> direct plug-in <input type="checkbox"/> mating connector <input type="checkbox"/> pluggable equipment type B - <input type="checkbox"/> non-detachable supply cord <input type="checkbox"/> appliance coupler <input type="checkbox"/> permanent connection <input type="checkbox"/> mating connector <input type="checkbox"/> other:_____ |
| Considered current rating of protective device as part of building or equipment installation | 16 or 20 A; Installation location: <input checked="" type="checkbox"/> building; <input type="checkbox"/> equipment |
| Equipment mobility | <input type="checkbox"/> movable <input type="checkbox"/> hand-held <input type="checkbox"/> transportable <input type="checkbox"/> stationary <input type="checkbox"/> for building-in <input checked="" type="checkbox"/> direct plug-in <input type="checkbox"/> rack-mounting <input type="checkbox"/> wall-mounted |
| Over voltage category (OVC) | <input type="checkbox"/> OVC I <input checked="" type="checkbox"/> OVC II <input type="checkbox"/> OVC III <input type="checkbox"/> OVC IV <input type="checkbox"/> other: _____ |
| Class of equipment | <input checked="" type="checkbox"/> Class I (only for open frame model series) <input checked="" type="checkbox"/> Class II <input type="checkbox"/> Class III |
| Access location | <input type="checkbox"/> restricted access location <input checked="" type="checkbox"/> N/A |
| Pollution degree (PD) | <input type="checkbox"/> PD 1 <input checked="" type="checkbox"/> PD 2 <input type="checkbox"/> PD 3 |
| Manufacturer’s specified maxium operating ambient: | 50 °C |
| IP protection class | <input type="checkbox"/> IPX0 <input checked="" type="checkbox"/> IP20 |
| Power Systems | <input checked="" type="checkbox"/> TN <input checked="" type="checkbox"/> TT <input type="checkbox"/> IT - ____ V _{L-L} |
| Altitude during operation (m) | <input type="checkbox"/> 2000 m or less <input checked="" type="checkbox"/> <5000 m |
| Altitude of test laboratory (m) | <input type="checkbox"/> 2000 m or less <input checked="" type="checkbox"/> <50 m |
| Mass of equipment (kg) | <input checked="" type="checkbox"/> Approx. 0.14 kg |

| | |
|---|--|
| POSSIBLE TEST CASE VERDICTS: | |
| - test case does not apply to the test object..... : | N/A |
| - test object does meet the requirement : | P (Pass) |
| - test object does not meet the requirement : | F (Fail) |
| TESTING: | |
| Date of receipt of test item..... : | 2015-11-16 |
| Date (s) of performance of tests..... : | 2015-11-16 ~ 2015-12-01 |
| GENERAL REMARKS: | |
| <p>"(See Enclosure #)" refers to additional information appended to the report. "(See appended table)" refers to a table appended to the report.</p> <p>Throughout this report a <input type="checkbox"/> comma / <input checked="" type="checkbox"/> point is used as the decimal separator. Determination of the test result includes consideration of measurement uncertainty from the test equipment and methods.</p> <p><i>This report is for the exclusive use of Intertek's Client and is provided pursuant to the agreement between Intertek and its Client. Intertek's responsibility and liability are limited to the terms and conditions of the agreement. Intertek assumes no liability to any party, other than to the Client in accordance with the agreement, for any loss, expense or damage occasioned by the use of this report. Only the Client is authorized to permit copying or distribution of this report and then only in its entirety. Any use of the Intertek name or one of its marks for the sale or advertisement of the tested material, product or service must first be approved in writing by Intertek. The observations and test results in this report are relevant only to the sample tested. This report by itself does not imply that the material, product, or service is or has ever been under an Intertek certification program.</i></p> | |
| Manufacturer's Declaration per sub-clause 4.2.5 of IEC62011-1: | |
| The application for obtaining a CB Test Certificate includes more than one factory location and a declaration from the Manufacturer stating that the sample(s) submitted for evaluation is (are) representative of the products from each factory has been provided | <input checked="" type="checkbox"/> Yes <input type="checkbox"/> Not applicable |
| When differences exist; they shall be identified in the General product information section. | |
| Name and address of factory (ies) | Factory 1: GlobTek, Inc. 186 Veterans Dr. Northvale, NJ 07647 USA Factory 2: GlobTek (Suzhou) Co., Ltd Building 4, No. 76, Jin Ling East Rd., Suzhou Industrial Park, Suzhou, JiangSu 215021, China |
| GENERAL PRODUCT INFORMATION: | |

Product Description – Product covered by this report is ITE power supply module. The different models are corresponding to four structure types respectively.

One is direct plug-in power adapter with interchangeable plug portion, which is Class II apparatus. It can be used with different plug types. The evaluation reports of the different plug types are also attached with this report. Two pieces of outer enclosure are enclosed with ultrasonic welding without screw.

The other one is open frame type which also provides a protective earth bonding terminal on the PCB. Interchangeable appliance inlets can be mounted on the device, which can provide earthing connection or not. The installation and use for the insulation construction shall be finally determined in the end product.

Model GT-41134-0606-W2-TAB is special direct plug-in type for North America market, with particular housing, varistor and fixed NEMA 1-15P plug.

One structure type only use F1 fuse in primary circuit and a LED indicator (optional) used in secondary circuit.

GT*96060***** is identify with GT*41134***** except for model name.

GT*96060***** and GT*41134***** were evaluated for maximum manufacturer’s recommended ambient of 50 °C.

GT-41134-0606-W2-TAB was evaluated for maximum manufacturer’s recommended ambient of 50 °C.

All the types are designed for continuous operation.

Model Differences –

GT*41134***** and GT*96060*****

The 1st “*” part can be ‘M’ or ‘-’ or ‘H’ for market identification and not related to safety.

The 2nd “*” part can be “-” or “CC”, “-” = Constant Voltage Model, CC = Constant Current Model.

The 3rd “*” denotes the rated output wattage designation, which can be “01” to “06”, with interval of 1.

The 4th “*” denotes the standard rated output voltage designation, which can be “03”, “04”, “06”, “12”, “15”, “18”, “24”, “36” or “48”. These standard rated output voltage designations correspond to seven isolated transformer models (See the appended table 4.1.2 for details). Each transformer model is identical in insulation construction including clearance and creepage except number of turns per coil.

The 5th “*” is optional deviation, subtracted from standard output voltage, which can be “-0.1” to “-11.9” with interval of 0.1, or blank to indicate no voltage different.

The 4th “*” and 5th “*” together denote the output voltage, with a range of 3.3 - 48 volts.

The 6th “*” =Blank means directly plug in model series,

= “-F” means Class I open frame model with connector which is fixing on the PCB,

= “-FW” means Class II open frame model with connector which is fixing on the PCB.

= “-FWT2” means open frame model with appliance inlet with Class II inlet C8 respectively,

= “-FT3A” means open frame model with appliance inlet with Class I inlet C6 respectively,

= “-FT3” means open frame model with appliance inlet with Class I inlet C14 respectively,

The last * denote any six character = 0-9 or A-Z or () [] or – or blank for marketing purposes.

Test performed on 3.3V, 5V, 9V and 48V output model as representative, and also performed on model GT-41134-0606-W2-TAB for reference. Test performed on 3.3V, 5V and 48V output model as representative for new added structure type.

Model list:

| Model | voltage | Max. current | Max. power |
|------------------------------------|---------|--------------|------------|
| GT*41134**03*** GT*96060**03*** | 3.3V | 1.8A | 6W |
| GT*41134**04*** GT*96060**04*** | 3.4-4V | 1.76A | 6W |
| GT*41134**06*** GT*96060**06*** | 4.1-6V | 1.46A | 6W |
| GT*41134**12*** GT*96060**12*** | 6.1-12V | 0.98A | 6W |

| | | | |
|------------------------------------|----------|-------|----|
| GT*41134**15*** GT*96060**15*** | 12.1-15V | 0.50A | 6W |
| GT*41134**18*** GT*96060**18*** | 15.1-18V | 0.40A | 6W |
| GT*41134**24*** GT*96060**24*** | 18.1-24V | 0.33A | 6W |
| GT*41134**36*** GT*96060**36*** | 24.1-36V | 0.25A | 6W |
| GT*41134**48*** GT*96060**48*** | 36.1-48V | 0.16A | 6W |
| GT-41134-0606-W2-TAB | 6V | 1A | 6W |

Additional application considerations –

- normal conditions **N.C.**
- functional insulation **FI**
- double insulation **DI**
- between parts of opposite polarity BOP
- short circuit **SC**
- overload **O/L**
- single fault conditions **S.F.C**
- basic insulation **BI**
- supplementary insulation **SI**
- reinforced insulation RI
- open circuit **OC**

Indicate used abbreviations (if any)

N/A

| ENERGY SOURCE IDENTIFICATION AND CLASSIFICATION TABLE: | |
|---|--|
| (Note 1: Identify the following six (6) energy source forms based on the origin of the energy.) (Note 2: The identified classification e.g., ES2, TS1, should be with respect to its ability to cause pain or injury on the body or its ability to ignite a combustible material. Any energy source can be declared Class 3 as a worse case classification e.g. PS3, ES3.) | |
| Electrically-caused injury (Clause 5): (Note: Identify type of source, list sub-assembly or circuit designation and corresponding energy source classification) Example: +5 V dc input ES1 | |
| Source of electrical energy | Corresponding classification (ES) |
| Internal primary circuit of built-in power supply | ES3 |
| Internal secondary circuit after T1 sec. output or C5 of built-in power supply | ES1 |
| Electrically-caused fire (Clause 6): (Note: List sub-assembly or circuit designation and corresponding energy source classification) Example: Battery pack (maximum 85 watts): PS2 | |
| Source of power or PIS | Corresponding classification (PS) |
| All primary circuits and secondary circuits inside the equipment enclosure | PS3 |
| Secondary output connector | PS1 |
| Injury caused by hazardous substances (Clause 7) (Note: Specify hazardous chemicals, whether produces ozone or other chemical construction not addressed as part of the component evaluation.) Example: Liquid in filled component Glycol | |
| Source of hazardous substances | Corresponding chemical |
| N/A | N/A |
| N/A | N/A |
| Mechanically-caused injury (Clause 8) (Note: List moving part(s), fan, special installations, etc. & corresponding MS classification based on Table 35.) Example: Wall mount unit MS2 | |
| Source of kinetic/mechanical energy | Corresponding classification (MS) |
| Sharp edges and corners | MS1 |
| Equipment mass | MS1 |
| Thermal burn injury (Clause 9) (Note: Identify the surface or support, and corresponding energy source classification based on type of part, location, operating temperature and contact time in Table 38.) Example: Hand-held scanner – thermoplastic enclosure TS1 | |
| Source of thermal energy | Corresponding classification (TS) |
| Accessible surfaces which is touched occasionally for very short periods | TS1 |
| -- | -- |
| Radiation (Clause 10) (Note: List the types of radiation present in the product and the corresponding energy source classification.) Example: DVD – Class 1 Laser Product RS1 | |
| Type of radiation | Corresponding classification (RS) |
| LED indicator | RS1 |

| ENERGY SOURCE IDENTIFICATION AND CLASSIFICATION TABLE: | |
|---|-----|
| N/A | N/A |

| ENERGY SOURCE DIAGRAM |
|--|
| Indicate which energy sources are included in the energy source diagram. Insert diagram below |
| <input type="checkbox"/> ES <input type="checkbox"/> PS <input type="checkbox"/> MS <input type="checkbox"/> TS <input type="checkbox"/> RS |

| OVERVIEW OF EMPLOYED SAFEGUARDS | | | | |
|---|---|--------------------------|-------------------|---------------------------|
| Clause | Possible Hazard | | | |
| 5.1 | Electrically-caused injury | | | |
| Body Part (e.g. Ordinary) | Energy Source (ES3: Primary Filter circuit) | Safeguards | | |
| | | Basic | Supplementary | Reinforced (Enclosure) |
| Ordinary | ES3: Internal primary circuit of built-in power supply | N/A | N/A | Enclosure |
| Ordinary | ES1: Internal secondary circuit after T1 sec. output or C5 of built-in power supply | N/A | N/A | N/A |
| 6.1 | Electrically-caused fire | | | |
| Material part (e.g. mouse enclosure) | Energy Source (PS2: 100 Watt circuit) | Safeguards | | |
| | | Basic | Supplementary | Reinforced |
| All combustible materials within equipment fire enclosure | PS3: All primary circuits and secondary circuits inside the equipment enclosure | No excessive temperature | Suitable Material | N/A |
| All external wiring materials | PS1: Secondary output wire | N/A | N/A | N/A |
| 7.1 | Injury caused by hazardous substances | | | |
| Body Part (e.g., skilled) | Energy Source (hazardous material) | Safeguards | | |
| | | Basic | Supplementary | Reinforced |
| N/A | N/A | N/A | N/A | N/A |
| N/A | N/A | N/A | N/A | N/A |
| 8.1 | Mechanically-caused injury | | | |
| Body Part (e.g. Ordinary) | Energy Source (MS3:High Pressure Lamp) | Safeguards | | |
| | | Basic | Supplementary | Reinforced (Enclosure) |
| Ordinary | MS1: Sharp edges and corners | N/A | N/A | N/A |
| Ordinary | MS1: Equipment mass | N/A | N/A | N/A |
| 9.1 | Thermal Burn | | | |
| Body Part (e.g., Ordinary) | Energy Source (TS2) | Safeguards | | |
| | | Basic | Supplementary | Reinforced |
| Ordinary | TS1: Accessible surfaces | N/A | N/A | N/A |
| -- | -- | -- | -- | -- |
| 10.1 | Radiation | | | |
| Body Part (e.g., Ordinary) | Energy Source (Output from audio port) | Safeguards | | |
| | | Basic | Supplementary | Reinforced |

| | | | | |
|----------|--------------------|-----|-----|-----|
| Ordinary | RS1: LED indicator | N/A | N/A | N/A |
| N/A | N/A | N/A | N/A | N/A |

Supplementary Information:

(1) See attached energy source diagram for additional details.

(2) "N" – Normal Condition; "A" – Abnormal Condition; "S" Single Fault

| IEC 62368-1 | | | |
|-------------|--------------------|-----------------|---------|
| Clause | Requirement + Test | Result - Remark | Verdict |

| 4 | GENERAL REQUIREMENTS | | P |
|----------|--|--|-----|
| 4.1.1 | Acceptance of materials, components and subassemblies | (See appended table 4.1.2) | P |
| 4.1.2 | Use of components | (See appended table 4.1.2) | P |
| 4.1.3 | Equipment design and construction | | P |
| 4.1.15 | Markings and instructions.....: | (See Annex F) | P |
| 4.4.4 | Safeguard robustness | | P |
| 4.4.4.2 | Steady force tests.....: | (See Annex T.4, T.5) | P |
| 4.4.4.3 | Drop tests | (See Annex T.7) | P |
| 4.4.4.4 | Impact tests | Only for Direct plug-in type model series. For open frame model series shall be evaluated at end product level. | N/A |
| 4.4.4.5 | Internal accessible safeguard enclosure and barrier tests.....: | No such parts | N/A |
| 4.4.4.6 | Glass Impact tests | No glass | N/A |
| 4.4.4.74 | Thermoplastic material tests.....: | (See Annex T.8) | P |
| 4.4.4.8 | Air comprising a safeguard.....: | (See Annex T) | P |
| 4.4.4.9 | Accessibility and safeguard effectiveness | | P |
| 4.5 | Explosion | | P |
| 4.6 | Fixing of conductors | | P |
| 4.6.1 | Fix conductors not to defeat a safeguard | | P |
| 4.6.2 | 10 N force test applied to | Internal wire or components | P |
| 4.7 | Equipment for direct insertion into mains socket - outlets | | P |
| 4.7.2 | Mains plug part complies with the relevant standard.....: | (See Evaluation sheet for plug portion) | P |
| 4.7.3 | Torque (Nm) | Max. 0.07 Nm | P |
| 4.8 | Products containing coin/button cell batteries | | N/A |
| 4.8.2 | Instructional safeguard | | N/A |
| 4.8.3 | Battery Compartment Construction | No battery | N/A |
| | Means to reduce the possibility of children removing the battery.....: | | — |
| 4.8.4 | Battery Compartment Mechanical Tests | | N/A |
| 4.8.5 | Battery Accessibility | | N/A |
| 4.9 | Likelihood of fire or shock due to entry of conductive object.....: | No openings. Can't be entry. | N/A |

| IEC 62368-1 | | | |
|-------------|--------------------|-----------------|---------|
| Clause | Requirement + Test | Result - Remark | Verdict |

| | | | |
|-----------|---|---|-----|
| 5 | ELECTRICALLY-CAUSED INJURY | | P |
| 5.2.1 | Electrical energy source classifications..... : | ES3: Internal primary circuit of built-in power supply ES1: Internal secondary circuit after T1 sec. output or C5 of built-in power supply | P |
| 5.2.2 | ES1, ES2 and ES3 limits | | P |
| 5.2.2.2 | Steady-state voltage and current..... : | (See appended table 5.2) | P |
| 5.2.2.3 | Capacitance limits | | N/A |
| 5.2.2.4 | Single pulse limits | | N/A |
| 5.2.2.5 | Limits for repetitive pulses | | N/A |
| 5.2.2.6 | Ringing signals | | N/A |
| 5.2.2.7 | Audio signals | | N/A |
| 5.3 | Protection against electrical energy sources | See table "OVERVIEW OF EMPLOYED SAFEGUARDS" | P |
| 5.3.1 | General Requirements for accessible parts to ordinary, instructed and skilled persons | | P |
| 5.3.2.1 | Accessibility to electrical energy sources and safeguards | | P |
| 5.3.2.2 | Contact requirements | | P |
| | a) Test with test probe from Annex V | ES3 voltages less than 420 V peak | P |
| | b) Electric strength test potential (V) | | N/A |
| | c) Air gap (mm) | | N/A |
| 5.3.2.4 | Terminals for connecting stripped wire | | P |
| 5.4 | Insulation materials and requirements | | P |
| 5.4.1.2 | Properties of insulating material | | P |
| 5.4.1.3 | Humidity conditioning | No hygroscopic material | N/A |
| 5.4.1.4 | Maximum operating temperature for insulating materials | Considered to be class 130 (B) | P |
| 5.4.1.5 | Pollution degree | Pollution degree 2 | — |
| 5.4.1.5.2 | Test for pollution degree 1 environment and for an insulating compound | | N/A |
| 5.4.1.5.3 | Thermal cycling | | N/A |
| 5.4.1.6 | Insulation in transformers with varying dimensions | | N/A |
| 5.4.1.7 | Insulation in circuits generating starting pulses | | N/A |
| 5.4.1.8 | Determination of working voltage | | P |
| 5.4.1.9 | Insulating surfaces | | P |

| IEC 62368-1 | | | |
|--------------------|---|--|---------|
| Clause | Requirement + Test | Result - Remark | Verdict |
| 5.4.1.10 | Thermoplastic parts on which conductive metallic parts are directly mounted | | P |
| 5.4.1.10.2 | Vicat softening temperature..... : | | N/A |
| 5.4.1.10.3 | Ball pressure : | (See appended table 5.4.1.10.3) | P |
| 5.4.2 | Clearances | | P |
| 5.4.2.2 | Determining clearance using peak working voltage | (See appended table 5.4.2.2) | P |
| 5.4.2.3 | Determining clearance using required withstand voltage : | (See appended table 5.4.2.3) | P |
| | a) a.c. mains transient voltage : | 2500Vpeak | — |
| | b) d.c. mains transient voltage : | | — |
| | c) external circuit transient voltage : | | — |
| | d) transient voltage determined by measurement ... : : | | — |
| 5.4.2.4 | Determining the adequacy of a clearance using an electric strength test | (See appended table 5.4.2.4) | N/A |
| 5.4.2.5 | Multiplication factors for clearances and test voltages : | 1.48 for clearances | P |
| 5.4.3 | Creepage distances : | (See appended table 5.4.3) | P |
| 5.4.3.1 | General | | P |
| 5.4.3.3 | Material Group : | Material group IIIb is used | — |
| 5.4.4 | Solid insulation | | P |
| 5.4.4.2 | Minimum distance through insulation : | (See appended table 5.4.4.2) | P |
| 5.4.4.3 | Insulation compound forming solid insulation | | N/A |
| 5.4.4.4 | Solid insulation in semiconductor devices | | N/A |
| 5.4.4.5 | Cemented joints | | N/A |
| 5.4.4.6 | Thin sheet material | The thin sheet materials of polyester tape used in transformers. | P |
| 5.4.4.6.1 | General requirements | | P |
| 5.4.4.6.2 | Separable thin sheet material | | P |
| | Number of layers (pcs) : | 3 layers | P |
| 5.4.4.6.3 | Non-separable thin sheet material | Triple-insulating winding | P |
| 5.4.4.6.4 | Standard test procedure for non-separable thin sheet material : | Approved TIW used | N/A |
| 5.4.4.6.5 | Mandrel test | | N/A |
| 5.4.4.7 | Solid insulation in wound components | | N/A |
| 5.4.4.9 | Solid insulation at frequencies >30 kHz : | | N/A |
| 5.4.5 | Antenna terminal insulation | | N/A |
| 5.4.5.1 | General | | N/A |

| IEC 62368-1 | | | |
|--------------------|---|------------------------------|---------|
| Clause | Requirement + Test | Result - Remark | Verdict |
| 5.4.5.2 | Voltage surge test | | N/A |
| | Insulation resistance (MΩ).....: | | — |
| 5.4.6 | Insulation of internal wire as part of supplementary safeguard.....: | (See appended table 5.4.4.2) | N/A |
| 5.4.7 | Tests for semiconductor components and for cemented joints | | N/A |
| 5.4.8 | Humidity conditioning | | P |
| | Relative humidity (%).....: | 93 | — |
| | Temperature (°C) | 40 | — |
| | Duration (h) | 120 | — |
| 5.4.9 | Electric strength test.....: | (See appended table 5.4.9) | P |
| 5.4.9.1 | Test procedure for a solid insulation type test | | P |
| 5.4.9.2 | Test procedure for routine tests | | P |
| 5.4.10 | Protection against transient voltages between external circuit | | N/A |
| 5.4.10.1 | Parts and circuits separated from external circuits | | N/A |
| 5.4.10.2 | Test methods | | N/A |
| 5.4.10.2.1 | General | | N/A |
| 5.4.10.2.2 | Impulse test | | N/A |
| 5.4.10.2.3 | Steady-state test.....: | | N/A |
| 5.4.11 | Insulation between external circuits and earthed circuitry | | N/A |
| 5.4.11.1 | Exceptions to separation between external circuits and earth | | N/A |
| 5.4.11.2 | Requirements | | N/A |
| | Rated operating voltage U_{op} (V).....: | | — |
| | Nominal voltage U_{peak} (V).....: | | — |
| | Max increase due to variation U_{sp} | | — |
| | Max increase due to ageing ΔU_{sa} | | — |
| | $U_{op} = U_{peak} + \Delta U_{sp} + \Delta U_{sa}$ | | — |
| 5.5 | Components as safeguards | | |
| 5.5.1 | General | | P |
| 5.5.2 | Capacitors and RC units | | P |
| 5.5.2.1 | General requirement | | P |
| 5.5.2.2 | Safeguards against capacitor discharge after disconnection of a connector.....: | | N/A |
| 5.5.3 | Transformers | (See Annex G.5.3) | P |

| IEC 62368-1 | | | |
|--------------------|---|---|---------|
| Clause | Requirement + Test | Result - Remark | Verdict |
| 5.5.4 | Optocouplers | | N/A |
| 5.5.5 | Relays | | N/A |
| 5.5.6 | Resistors | | N/A |
| 5.5.7 | SPD's | (See Annex G.8) | P |
| 5.5.7.1 | Use of an SPD connected to reliable earthing | | N/A |
| 5.5.7.2 | Use of an SPD between mains and protective earth | | N/A |
| 5.5.8 | Insulation between the mains and external circuit consisting of a coaxial cable.....: | (See Annex G.10.3) | N/A |
| 5.6 | Protective conductor | | N/A |
| 5.6.2 | Requirement for protective conductors | Open frame model series shall be evaluated at end product level. | N/A |
| 5.6.2.1 | General requirements | | N/A |
| 5.6.2.2 | Colour of insulation | | N/A |
| 5.6.3 | Requirement for protective earthing conductors | | N/A |
| | Protective earthing conductor size (mm ²) | | — |
| 5.6.4 | Requirement for protective bonding conductors | | N/A |
| 5.6.4.1 | Protective bonding conductors | | N/A |
| | Protective bonding conductor size (mm ²). | | — |
| | Protective current rating (A) | | — |
| 5.6.4.3 | Current limiting and overcurrent protective devices | | N/A |
| 5.6.5 | Terminals for protective conductors | | N/A |
| 5.6.5.1 | Requirement | | N/A |
| | Conductor size (mm ²), nominal thread diameter (mm). | | N/A |
| 5.6.5.2 | Corrosion | | N/A |
| 5.6.6 | Resistance of the protective system | | N/A |
| 5.6.6.1 | Requirements | | N/A |
| 5.6.6.2 | Test Method Resistance (Ω).....: | | N/A |
| 5.6.7 | Reliable earthing | | N/A |
| 5.7 | Prospective touch voltage, touch current and protective conductor current | | P |
| 5.7.2 | Measuring devices and networks | | P |
| 5.7.2.1 | Measurement of touch current | L/N – terminal: U2=0.054mA, U3=0.072mA L/N – plastic enclosure: U2=0.024mA, U3=0.025mA | P |

| IEC 62368-1 | | | |
|-------------|--------------------|-----------------|---------|
| Clause | Requirement + Test | Result - Remark | Verdict |

| | | | |
|---------|---|--|-----|
| 5.7.2.2 | Measurement of prospective touch voltage | Open frame model series shall be evaluated at end product level. | N/A |
| 5.7.3 | Equipment set-up, supply connections and earth connections | | N/A |
| | System of interconnected equipment (separate connections/single connection) | | — |
| | Multiple connections to mains (one connection at a time/simultaneous connections) | | — |
| 5.7.4 | Earthed conductive accessible parts | (See appended Table 5.7.4) | N/A |
| 5.7.5 | Protective conductor current | | N/A |
| | Supply Voltage (V)..... | | — |
| | Measured current (mA)..... | | — |
| | Instructional Safeguard..... | (See F.4 and F.5) | N/A |
| 5.7.6 | Prospective touch voltage and touch current due to external circuits | | N/A |
| 5.7.6.1 | Touch current from coaxial cables | | N/A |
| 5.7.6.2 | Prospective touch voltage and touch current from external circuits | | N/A |
| 5.7.7 | Summation of touch currents from external circuits | | N/A |
| | a) Equipment with earthed external circuits Measured current (mA)..... | | N/A |
| | b) Equipment whose external circuits are not referenced to earth. Measured current (mA) | | N/A |

| | | | |
|----------|---|--|----------|
| 6 | ELECTRICALLY- CAUSED FIRE | | P |
| 6.2 | Classification of power sources (PS) and potential ignition sources (PIS) | | P |
| 6.2.2 | Power source circuit classifications | | P |
| 6.2.2.1 | General | | P |
| 6.2.2.2 | Power measurement for worst-case load fault ... : | (See appended table 6.2.2) | P |
| 6.2.2.3 | Power measurement for worst-case power source fault | (See appended table 6.2.2) | P |
| 6.2.2.4 | PS1 | Secondary output connector | P |
| 6.2.2.5 | PS2 | No such circuit | N/A |
| 6.2.2.6 | PS3 | All primary circuits and secondary circuits inside the equipment enclosure | P |
| 6.2.3 | Classification of potential ignition sources | | P |
| 6.2.3.1 | Arcing PIS | All PS3 parts or circuit in the fire enclosure | P |

| IEC 62368-1 | | | |
|--------------------|--|--|---------|
| Clause | Requirement + Test | Result - Remark | Verdict |
| 6.2.3.2 | Resistive PIS | All PS3 parts or circuit in the fire enclosure | P |
| 6.3 | Safeguards against fire under normal operating and abnormal operating conditions | | P |
| 6.3.1 (a) | No ignition and attainable temperature value less than 90 % defined by ISO 871 or less than 300 °C for unknown materials | (See appended table 5.4.1.5, 6.3.2, 9.0, B.2.6) | P |
| 6.3.1 (b) | Combustible materials outside fire enclosure | | P |
| 6.4 | Safeguards against fire under single fault conditions | | P |
| 6.4.1 | Safeguard Method | | P |
| 6.4.2 | Reduction of the likelihood of ignition under single fault conditions in PS1 circuits | | P |
| 6.4.3 | Reduction of the likelihood of ignition under single fault conditions in PS2 and PS3 circuits | | P |
| 6.4.3.1 | General | | P |
| 6.4.3.2 | Supplementary Safeguards | | P |
| | Special conditions if conductors on printed boards are opened or peeled | | P |
| 6.4.3.3 | Single Fault Conditions | (See appended table 6.4.3) | P |
| | Special conditions for temperature limited by fuse | | N/A |
| 6.4.4 | Control of fire spread in PS1 circuits | | P |
| 6.4.5 | Control of fire spread in PS2 circuits | | N/A |
| 6.4.5.2 | Supplementary safeguards | (See appended tables 4.1.2 and Annex G) | N/A |
| 6.4.6 | Control of fire spread in PS3 circuit | | P |
| 6.4.7 | Separation of combustible materials from a PIS | | P |
| 6.4.7.1 | General | (See tables 6.2.3.1 and 6.2.3.2) | P |
| 6.4.7.2 | Separation by distance | | N/A |
| 6.4.7.3 | Separation by a fire barrier | | N/A |
| 6.4.8 | Fire enclosures and fire barriers | | P |
| 6.4.8.1 | Fire enclosure and fire barrier material properties | | P |
| 6.4.8.2.1 | Requirements for a fire barrier | | N/A |
| 6.4.8.2.2 | Requirements for a fire enclosure | Min. V-1 | P |
| 6.4.8.3 | Constructional requirements for a fire enclosure and a fire barrier | | P |
| 6.4.8.3.1 | Fire enclosure and fire barrier openings | | P |
| 6.4.8.3.2 | Fire barrier dimensions | | N/A |
| 6.4.8.3.3 | Top Openings in Fire Enclosure: dimensions (mm) | For open frame model series, shall be evaluated at end product level. For other models, no opening. | P |

| IEC 62368-1 | | | |
|--------------------|--|--|---------|
| Clause | Requirement + Test | Result - Remark | Verdict |
| | Needle Flame test | | N/A |
| 6.4.8.3.4 | Bottom Openings in Fire Enclosure, condition met a), b) and/or c) dimensions (mm) | For open frame model series, shall be evaluated at end product level. For other models, no opening. | P |
| | Flammability tests for the bottom of a fire enclosure | | N/A |
| 6.4.8.3.5 | Integrity of the fire enclosure, condition met: a), b) or c) | | N/A |
| 6.4.8.4 | Separation of PIS from fire enclosure and fire barrier distance (mm) or flammability rating..... | | N/A |
| 6.5 | Internal and external wiring | | P |
| 6.5.1 | Requirements | | P |
| 6.5.2 | Cross-sectional area (mm ²) | 18AWG=0.75 mm ² | — |
| 6.5.3 | Requirements for interconnection to building wiring | (See Annex Q.) | N/A |
| 6.6 | Safeguards against fire due to connection to additional equipment | | N/A |
| | External port limited to PS2 or complies with Clause Q.1 | | N/A |

| IEC 62368-1 | | | |
|-------------|--------------------|-----------------|---------|
| Clause | Requirement + Test | Result - Remark | Verdict |

| | | | |
|----------|--|--|-----|
| 7 | INJURY CAUSED BY HAZARDOUS SUBSTANCES | | N/A |
| 7.2 | Reduction of exposure to hazardous substances | | N/A |
| 7.3 | Ozone exposure | | N/A |
| 7.4 | Use of personal safeguards (PPE) | | N/A |
| | Personal safeguards and instructions | | — |
| 7.5 | Use of instructional safeguards and instructions | | N/A |
| | Instructional safeguard (ISO 7010) | | — |
| 7.6 | Batteries..... | | N/A |

| | | | |
|-----------|---|----------------------|-----|
| 8 | MECHANICALLY-CAUSED INJURY | | P |
| 8.1 | General | | P |
| 8.2 | Mechanical energy source classifications | | P |
| 8.3 | Safeguards against mechanical energy sources | | P |
| 8.4 | Safeguards against parts with sharp edges and corners | | P |
| 8.4.1 | Safeguards | MS1 | N/A |
| 8.5 | Safeguards against moving parts | No moving parts | N/A |
| 8.5.1 | MS2 or MS3 part required to be accessible for the function of the equipment | | N/A |
| 8.5.2 | Instructional Safeguard..... | | — |
| 8.5.4 | Special categories of equipment comprising moving parts | | N/A |
| 8.5.4.1 | Large data storage equipment | | N/A |
| 8.5.4.2 | Equipment having electromechanical device for destruction of media | | N/A |
| 8.5.4.2.1 | Safeguards and Safety Interlocks | | N/A |
| 8.5.4.2.2 | Instructional safeguards against moving parts | | N/A |
| | Instructional Safeguard..... | | — |
| 8.5.4.2.3 | Disconnection from the supply | | N/A |
| 8.5.4.2.4 | Probe type and force (N) | | N/A |
| 8.5.5 | High Pressure Lamps | | N/A |
| 8.5.5.1 | Energy Source Classification | | N/A |
| 8.5.5.2 | High Pressure Lamp Explosion Test..... | | N/A |
| 8.6 | Stability | Approx. 0.14 kg, MS1 | N/A |
| 8.6.1 | Product classification | | N/A |

| IEC 62368-1 | | | |
|-------------|--------------------|-----------------|---------|
| Clause | Requirement + Test | Result - Remark | Verdict |

| | | | |
|---------|---|--|-----|
| | Instructional Safeguard.....: | | — |
| 8.6.2 | Static stability | | N/A |
| 8.6.2.2 | Static stability test | | N/A |
| | Applied Force | | — |
| 8.6.2.3 | Downward Force Test | | N/A |
| 8.6.3 | Relocation stability test | | N/A |
| | Unit configuration during 10° tilt.....: | | — |
| 8.6.4 | Glass slide test | | N/A |
| 8.6.5 | Horizontal force test (Applied Force).....: | | N/A |
| | Position of feet or movable parts.....: | | — |
| 8.7 | Equipment mounted to wall or ceiling | | N/A |
| 8.7.1 | Mounting Means (Length of screws (mm) and mounting surface) | | N/A |
| 8.7.2 | Direction and applied force | | N/A |
| 8.8 | Handles strength | | N/A |
| 8.8.1 | Classification | | N/A |
| 8.8.2 | Applied Force | | N/A |
| 8.9 | Wheels or casters attachment requirements | | N/A |
| 8.9.1 | Classification | | N/A |
| 8.9.2 | Applied force | | — |
| 8.10 | Carts, stands and similar carriers | | N/A |
| 8.10.1 | General | | N/A |
| 8.10.2 | Marking and instructions | | N/A |
| | Instructional Safeguard.....: | | — |
| 8.10.3 | Cart, stand or carrier loading test and compliance | | N/A |
| | Applied force | | — |
| 8.10.4 | Cart, stand or carrier impact test | | N/A |
| 8.10.5 | Mechanical stability | | N/A |
| | Applied horizontal force (N) | | — |
| 8.10.6 | Thermoplastic temperature stability (°C).....: | | N/A |
| 8.11 | Mounting means for rack mounted equipment | | N/A |
| 8.11.1 | General | | N/A |
| 8.11.2 | Product Classification | | N/A |
| 8.11.3 | Mechanical strength test, variable <i>N</i> | | N/A |
| 8.11.4 | Mechanical strength test 250N, including end stops | | N/A |

| IEC 62368-1 | | | |
|-------------|--------------------|-----------------|---------|
| Clause | Requirement + Test | Result - Remark | Verdict |

| | | | |
|------|----------------------------------|--|-----|
| 8.12 | Telescoping or rod antennas..... | | N/A |
| | Button/Ball diameter (mm).....: | | — |

| | | | |
|----------|--|------------------------------|----------|
| 9 | THERMAL BURN INJURY | | P |
| 9.2 | Thermal energy source classifications | TS1 for Accessible surfaces. | P |
| 9.3 | Safeguard against thermal energy sources | | N/A |
| 9.4 | Requirements for safeguards | | N/A |
| 9.4.1 | Equipment safeguard | | N/A |
| 9.4.2 | Instructional safeguard | | N/A |

| | | | |
|-----------|--|--------------------|----------|
| 10 | RADIATION | | P |
| 10.2 | Radiation energy source classification | RS1: LED indicator | P |
| 10.2.1 | General classification | | P |
| 10.3 | Protection against laser radiation | | N/A |
| | Laser radiation that exists equipment: | | — |
| | Normal, abnormal, single-fault.....: | | N/A |
| | Instructional safeguard | | — |
| | Tool.....: | | — |
| 10.4 | Protection against visible, infrared, and UV radiation | | N/A |
| 10.4.1 | General | | N/A |
| 10.4.1.a) | RS3 for Ordinary and instructed persons | | N/A |
| 10.4.1.b) | RS3 accessible to a skilled person.....: | | N/A |
| | Personal safeguard (PPE) instructional safeguard.....: | | — |
| 10.4.1.c) | Equipment visible, IR, UV does not exceed RS1. .: | | N/A |
| 10.4.1.d) | Normal, abnormal, single-fault conditions | | N/A |
| 10.4.1.e) | Enclosure material employed as safeguard is opaque.....: | | N/A |
| 10.4.1.f) | UV attenuation.....: | | N/A |
| 10.4.1.g) | Materials resistant to degradation UV | | N/A |
| 10.4.1.h) | Enclosure containment of optical radiation.....: | | N/A |
| 10.4.1.i) | Exempt Group under normal operating conditions.....: | | N/A |
| 10.4.2 | Instructional safeguard | | N/A |
| 10.5 | Protection against x-radiation | | N/A |
| 10.5.1 | X- radiation energy source that exists equipment : | | N/A |

| IEC 62368-1 | | | |
|--------------------|--------------------|-----------------|---------|
| Clause | Requirement + Test | Result - Remark | Verdict |

| | | | |
|----------|---|--|-----|
| | Normal, abnormal, single fault conditions | | N/A |
| | Equipment safeguards..... : | | N/A |
| | Instructional safeguard for skilled person..... : | | N/A |
| 10.5.3 | Most unfavourable supply voltage to give maximum radiation | | — |
| | Abnormal and single-fault condition | | N/A |
| | Maximum radiation (pA/kg)..... : | | N/A |
| 10.6 | Protection against acoustic energy sources | | N/A |
| 10.6.1 | General | | N/A |
| 10.6.2 | Classification | | N/A |
| | Acoustic output, dB(A) | | N/A |
| | Output voltage, unweighted r.m.s..... : | | N/A |
| 10.6.4 | Protection of persons | | N/A |
| | Instructional safeguards | | N/A |
| | Equipment safeguard prevent ordinary person to RS2..... : | | — |
| | Means to actively inform user of increase sound pressure..... : | | — |
| | Equipment safeguard prevent ordinary person to RS2..... : | | — |
| 10.6.5 | Requirements for listening devices (headphones, earphones, etc.) | | N/A |
| 10.6.5.1 | Corded passive listening devices with analog input | | N/A |
| | Input voltage with 94 dB(A) L_{Aeq} acoustic pressure output..... : | | — |
| 10.6.5.2 | Corded listening devices with digital input | | N/A |
| | Maximum dB(A) | | — |
| 10.6.5.3 | Cordless listening device | | N/A |
| | Maximum dB(A) | | — |

| | | | |
|----------|--|--|-----|
| B | NORMAL OPERATING CONDITION TESTS, ABNORMAL OPERATING CONDITION TESTS AND SINGLE FAULT CONDITION TESTS | | P |
| B.2 | Normal Operating Conditions | | P |
| B.2.1 | General requirements..... : | (See Test Item Particulars and appended test tables) | P |
| | Audio Amplifiers and equipment with audio amplifiers | | N/A |
| B.2.3 | Supply voltage and tolerances | | P |

| IEC 62368-1 | | | |
|-------------|--------------------|-----------------|---------|
| Clause | Requirement + Test | Result - Remark | Verdict |

| | | | |
|----------|---|----------------------------|-----|
| B.2.5 | Input test..... : | (See appended table B.2.5) | P |
| B.3 | Simulated abnormal operating conditions | | P |
| B.3.1 | General requirements..... : | (See appended table B.3) | P |
| B.3.2 | Covering of ventilation openings | | N/A |
| B.3.3 | D.C. mains polarity test | | N/A |
| B.3.4 | Setting of voltage selector..... : | No such parts | N/A |
| B.3.5 | Maximum load at output terminals : | (See appended table B.3) | P |
| B.3.6 | Reverse battery polarity | | N/A |
| B.3.7 | Abnormal operating conditions as specified in Clause E.2. | | N/A |
| B.3.8 | Safeguards functional during and after abnormal operating conditions | | P |
| B.4 | Simulated single fault conditions | | P |
| B.4.2 | Temperature controlling device open or short-circuited : | | N/A |
| B.4.3 | Motor tests | | N/A |
| B.4.3.1 | Motor blocked or rotor locked increasing the internal ambient temperature : | (See Clause G.5) | N/A |
| B.4.4 | Short circuit of functional insulation | | P |
| B.4.4.1 | Short circuit of clearances for functional insulation | | P |
| B.4.4.2 | Short circuit of creepage distances for functional insulation | | P |
| B.4.4.3 | Short circuit of functional insulation on coated printed boards | | N/A |
| B.4.5 | Short circuit and interruption of electrodes in tubes and semiconductors | | P |
| B.4.6 | Short circuit or disconnect of passive components | | P |
| B.4.7 | Continuous operation of components | | N/A |
| B.4.8 | Class 1 and Class 2 energy sources within limits during and after single fault conditions | | P |
| B.4.9 | Battery charging under single fault conditions ... : | | N/A |
| C | UV RADIATION | | N/A |
| C.1 | Protection of materials in equipment from UV radiation | | N/A |
| C.1.2 | Requirements | | N/A |
| C.1.3 | Test method | | N/A |
| C.2 | UV light conditioning test | | N/A |
| C.2.1 | Test apparatus | | N/A |
| C.2.2 | Mounting of test samples | | N/A |

| IEC 62368-1 | | | |
|-------------|--------------------|-----------------|---------|
| Clause | Requirement + Test | Result - Remark | Verdict |

| | | | |
|----------|---|-------------------|------------|
| C.2.3 | Carbon-arc light-exposure apparatus | | N/A |
| C.2.4 | Xenon-arc light exposure apparatus | | N/A |
| D | TEST GENERATORS | | N/A |
| D.1 | Impulse test generators | | N/A |
| D.2 | Antenna interface test generator | | N/A |
| D.3 | Electronic pulse generator | | N/A |
| E | TEST CONDITIONS FOR EQUIPMENT CONTAINING AUDIO AMPLIFIERS | | N/A |
| E.1 | Audio amplifier normal operating conditions | | N/A |
| | Audio signal voltage (V) | | — |
| | Rated load impedance (Ω) | | |
| E.2 | Audio amplifier abnormal operating conditions | | N/A |
| F | EQUIPMENT MARKINGS, INSTRUCTIONS, AND INSTRUCTIONAL SAFEGUARDS | | P |
| F.1 | General requirements | | P |
| | Instructions – Language | English | — |
| F.2 | Letter symbols and graphical symbols | | P |
| F.2.1 | Letter symbols according to IEC60027-1 | | P |
| F.2.2 | Graphic symbols IEC, ISO or manufacturer specific | | P |
| F.3 | Equipment markings | | P |
| F.3.1 | Equipment marking locations | | P |
| F.3.2 | Equipment identification markings | | P |
| F.3.2.1 | Manufacturer identification | See marking plate | — |
| F.3.2.2 | Model identification | See marking plate | — |
| F.3.3 | Equipment rating markings | | P |
| F.3.3.1 | Equipment with direct connection to mains | | P |
| F.3.3.2 | Equipment without direct connection to mains | | N/A |
| F.3.3.3 | Nature of supply voltage..... | See marking plate | — |
| F.3.3.4 | Rated voltage | See marking plate | — |
| F.3.3.4 | Rated frequency | See marking plate | — |
| F.3.3.6 | Rated current or rated power | See marking plate | — |
| F.3.3.7 | Equipment with multiple supply connections | | N/A |
| F.3.4 | Voltage setting device | | N/A |
| F.3.5 | Terminals and operating devices | | N/A |
| F.3.5.1 | Mains appliance outlet and socket-outlet markings..... | | N/A |
| F.3.5.2 | Switch position identification marking | | N/A |

| IEC 62368-1 | | | |
|-------------|--------------------|-----------------|---------|
| Clause | Requirement + Test | Result - Remark | Verdict |

| | | | |
|-----------|--|---|-----|
| F.3.5.3 | Replacement fuse identification and rating markings..... : | F1 & F2, T1A/250V for general model F1, T6.3A/250V for North America model | P |
| F.3.5.4 | Replacement battery identification marking | | N/A |
| F.3.5.5 | Terminal marking location | | N/A |
| F.3.6 | Equipment markings related to equipment classification | | N/A |
| F.3.6.1 | Class I Equipment | Open frame model series shall be evaluated at end product level. | N/A |
| F.3.6.1.1 | Protective earthing conductor terminal | | N/A |
| F.3.6.1.2 | Neutral conductor terminal | | N/A |
| F.3.6.1.3 | Protective bonding conductor terminals | | N/A |
| F.3.6.2 | Class II equipment (IEC60417-5172) | | P |
| F.3.6.2.1 | Class II equipment with or without functional earth | | P |
| F.3.6.2.2 | Class II equipment with functional earth terminal marking | | N/A |
| F.3.7 | Equipment IP rating marking | | — |
| F.3.8 | External power supply output marking | See marking plate | P |
| F.3.9 | Durability, legibility and permanence of marking | | P |
| F.3.10 | Test for permanence of markings | | P |
| F.4 | Instructions | | P |
| | a) Equipment for use in locations where children not likely to be present - marking | | N/A |
| | b) Instructions given for installation or initial use | | P |
| | c) Equipment intended to be fastened in place | | N/A |
| | d) Equipment intended for use only in restricted access area | | N/A |
| | e) Audio equipment terminals classified as ES3 and other equipment with terminals marked in accordance F.3.6.1 | | N/A |
| | f) Protective earthing employed as safeguard | | N/A |
| | g) Protective earthing conductor current exceeding ES 2 limits | | N/A |
| | h) Symbols used on equipment | | P |
| | i) Permanently connected equipment not provided with all-pole mains switch | | N/A |
| j) | j) Replaceable components or modules providing safeguard function | | N/A |
| F.5 | Instructional safeguards | | N/A |

| IEC 62368-1 | | | |
|--------------------|---|--|----------|
| Clause | Requirement + Test | Result - Remark | Verdict |
| | Where “instructional safeguard” is referenced in the test report it specifies the required elements, location of marking and/or instruction | | N/A |
| G | COMPONENTS | | P |
| G.1 | Switches | | N/A |
| G.1.1 | General requirements | | N/A |
| G.1.2 | Ratings, endurance, spacing, maximum load | | N/A |
| G.2 | Relays | | N/A |
| G.2.1 | General requirements | | N/A |
| G.2.2 | Overload test | | N/A |
| G.2.3 | Relay controlling connectors supply power | | N/A |
| G.2.4 | Mains relay, modified as stated in G.2 | | N/A |
| G.3 | Protection Devices | | P |
| G.3.1 | Thermal cut-offs | | N/A |
| G.3.1.1a) &b) | Thermal cut-outs separately approved according to IEC 60730 with conditions indicated in a) & b) | | N/A |
| G.3.1.1c) | Thermal cut-outs tested as part of the equipment as indicated in c) | | N/A |
| G.3.1.2 | Thermal cut-off connections maintained and secure | | N/A |
| G.3.2 | Thermal links | | N/A |
| G.3.2.1a) | Thermal links separately tested with IEC 60691 | | N/A |
| G.3.2.1b) | Thermal links tested as part of the equipment | | N/A |
| | Aging hours (H) : | | — |
| | Single Fault Condition : | | — |
| | Test Voltage (V) and Insulation Resistance (Ω) . : | | — |
| G.3.3 | PTC Thermistors | | N/A |
| G.3.4 | Overcurrent protection devices | | P |
| G.3.5 | Safeguards components not mentioned in G.3.1 to G.3.5 | | N/A |
| G.3.5.1 | Non-resettable devices suitably rated and marking provided | | N/A |
| G.3.5.2 | Single faults conditions..... : | (See appended Table B.4) | N/A |
| G.4 | Connectors | | N/A |
| G.4.1 | Spacings | | N/A |
| G.4.2 | Mains connector configuration : | Compliance with standard IEC 60083 & IEC 60320 | P |
| G.4.3 | Plug is shaped that insertion into mains socket-outlets or appliance coupler is unlikely | | N/A |

| IEC 62368-1 | | | |
|-------------|--------------------|-----------------|---------|
| Clause | Requirement + Test | Result - Remark | Verdict |

| | | | |
|--------------|--|---|-----|
| G.5 | Wound Components | | P |
| G.5.1 | Wire insulation in wound components..... | Approved TIW used | P |
| G.5.1.2 a) | Two wires in contact inside wound component, angle between 45° and 90° | | N/A |
| G.5.1.2 b) | Construction subject to routine testing | | N/A |
| G.5.2 | Endurance test on wound components | | N/A |
| G.5.2.1 | General test requirements | | N/A |
| G.5.2.2 | Heat run test | | N/A |
| | Time (s) | | — |
| | Temperature (°C) | | — |
| G.5.2.3 | Wound Components supplied by mains | | N/A |
| G.5.3 | Transformers | | P |
| G.5.3.1 | Requirements applied (IEC61204-7, IEC61558-1/-2, and/or IEC62368-1)..... | Tested with appliance | P |
| | Position..... | | — |
| | Method of protection | | — |
| G.5.3.2 | Insulation | | P |
| | Protection from displacement of windings..... | The end turns are reliably fixed by tape, the whole transformer varnished | — |
| G.5.3.3 | Overload test | (See appended table B.3) | P |
| G.5.3.3.1 | Test conditions | | P |
| G.5.3.3.2 | Winding Temperatures testing in the unit | | P |
| G.5.3.3.3 | Winding Temperatures - Alternative test method | | N/A |
| G.5.4 | Motors | | N/A |
| G.5.4.1 | General requirements | | N/A |
| | Position | | — |
| G.5.4.2 | Test conditions | | N/A |
| G.5.4.3 | Running overload test | | N/A |
| G.5.4.4 | Locked-rotor overload test | | N/A |
| | Test duration (days) | | — |
| G.5.4.5 | Running overload test for d.c. motors in secondary circuits | | N/A |
| G.5.4.5.2 | Tested in the unit | | N/A |
| | Electric strength test (V) | | — |
| G.5.4.5.3 | Tested on the Bench - Alternative test method; test time (h) | | N/A |

| IEC 62368-1 | | | |
|--------------------|--------------------|-----------------|---------|
| Clause | Requirement + Test | Result - Remark | Verdict |

| | | | |
|------------|---|-------------------------------|-----|
| | Electric strength test (V) | | — |
| G.5.4.6 | Locked-rotor overload test for d.c. motors in secondary circuits | | N/A |
| G.5.4.6.2 | Tested in the unit | | N/A |
| | Maximum Temperature | | N/A |
| | Electric strength test (V) | | N/A |
| G.5.4.6.3 | Tested on the bench - Alternative test method; test time (h) | | N/A |
| | Electric strength test (V) | | N/A |
| G.5.4.7 | Motors with capacitors | | N/A |
| G.5.4.8 | Three-phase motors | | N/A |
| G.5.4.9 | Series motors | | N/A |
| | Operating voltage | | — |
| G.6 | Wire Insulation | | N/A |
| G.6.1 | General | | N/A |
| G.6.2 | Solvent-based enamel wiring insulation | | N/A |
| G.7 | Mains supply cords | | N/A |
| G.7.1 | General requirements | | N/A |
| | Type..... | | — |
| | Rated current (A)..... | | — |
| | Cross-sectional area (mm ²), (AWG)..... | | — |
| G.7.2 | Compliance and test method | | N/A |
| G.7.3 | Cord anchorages and strain relief for non-detachable power supply cords | | N/A |
| G.7.3.2 | Cord strain relief | | N/A |
| G.7.3.2.1 | Requirements | | N/A |
| | Strain relief test force (N) | | — |
| G.7.3.2.2 | Strain relief mechanism failure | | N/A |
| G.7.3.2.3 | Cord sheath or jacket position, distance (mm)..... | | — |
| G.7.3.2.4 | Strain relief comprised of polymeric material | | N/A |
| G.7.4 | Cord Entry | (See appended table 5.4.11.1) | N/A |
| G.7.5 | Non-detachable cord bend protection | | N/A |
| G.7.5.1 | Requirements | | N/A |
| G.7.5.2 | Mass (g) | | — |
| | Diameter (m) | | — |
| | Temperature (°C) | | — |

| IEC 62368-1 | | | |
|--------------------|---|-----------------------------|---------|
| Clause | Requirement + Test | Result - Remark | Verdict |
| G.7.6 | Supply wiring space | | N/A |
| G.7.6.2 | Stranded wire | | N/A |
| G.7.6.2.1 | Test with 8 mm strand | | N/A |
| G.8 | Varistors | | P |
| G.8.1 | General requirements | Approved varistors used | P |
| G.8.2 | Safeguard against shock | | P |
| G.8.3 | Safeguard against fire | | N/A |
| G.8.3.2 | Varistor overload test | | N/A |
| G.8.3.3 | Temporary overvoltage | | N/A |
| G.9 | Integrated Circuit (IC) Current Limiters | | N/A |
| G.9.1 a) | Manufacturer defines limit at max. 5A. | | N/A |
| G.9.1 b) | Limiters do not have manual operator or reset | | N/A |
| G.9.1 c) | Supply source does not exceed 250 VA | | — |
| G.9.1 d) | IC limiter output current (max. 5A) | | — |
| G.9.1 e) | Manufacturers' defined drift | | — |
| G.9.2 | Test Program 1 | | N/A |
| G.9.3 | Test Program 2 | | N/A |
| G.9.4 | Test Program 3 | | N/A |
| G.10 | Resistors | | N/A |
| G.10.1 | General requirements | | N/A |
| G.10.2 | Resistor test | | N/A |
| G.10.3 | Test for resistors serving as safeguards between the mains and an external circuit consisting of a coaxial cable | | N/A |
| G.10.3.1 | General requirements | | N/A |
| G.10.3.2 | Voltage surge test | | N/A |
| G.10.3.3 | Impulse test | | N/A |
| G.11 | Capacitor and RC units | | P |
| G.11.1 | General requirements | Approved Y1 capacitors used | P |
| G.11.2 | Conditioning of capacitors and RC units | | P |
| G.11.3 | Rules for selecting capacitors | | P |
| G.12 | Optocouplers | | N/A |
| | Optocouplers comply with IEC 60747-5-5:2007 Spacing or Electric Strength Test (specify option and test results) | | N/A |
| | Type test voltage Vini | | — |
| | Routine test voltage, Vini,b | | — |

| IEC 62368-1 | | | |
|--------------------|--------------------|-----------------|---------|
| Clause | Requirement + Test | Result - Remark | Verdict |

| | | | |
|-------------|---|------------|-----|
| G.13 | Printed boards | | P |
| G.13.1 | General requirements | | P |
| G.13.2 | Uncoated printed boards | | P |
| G.13.3 | Coated printed boards | | N/A |
| G.13.4 | Insulation between conductors on the same inner surface | | N/A |
| | Compliance with cemented joint requirements (Specify construction)..... : | | — |
| G.13.5 | Insulation between conductors on different surfaces | | N/A |
| | Distance through insulation : | | N/A |
| | Number of insulation layers (pcs) : | | — |
| G.13.6 | Tests on coated printed boards | | N/A |
| G.13.6.1 | Sample preparation and preliminary inspection | | N/A |
| G.13.6.2a) | Thermal conditioning | | N/A |
| G.13.6.2b) | Electric strength test | | N/A |
| G.13.6.2c) | Abrasion resistance test | | N/A |
| G.14 | Coating on components terminals | | N/A |
| G.14.1 | Requirements : | (See G.13) | N/A |
| G.15 | Liquid filled components | | N/A |
| G.15.1 | General requirements | | N/A |
| G.15.2 | Requirements | | N/A |
| G.15.3 | Compliance and test methods | | N/A |
| G.15.3.1 | Hydrostatic pressure test | | N/A |
| G.15.3.2 | Creep resistance test | | N/A |
| G.15.3.3 | Tubing and fittings compatibility test | | N/A |
| G.15.3.4 | Vibration test | | N/A |
| G.15.3.5 | Thermal cycling test | | N/A |
| G.15.3.6 | Force test | | N/A |
| G.15.4 | Compliance | | N/A |
| G.16 | IC including capacitor discharge function (ICX) | | N/A |
| a) | Humidity treatment in accordance with sc5.4.8 – 120 hours | | N/A |
| b) | Impulse test using circuit 2 with $U_c =$ to transient voltage : | | N/A |
| C1) | Application of ac voltage at 110% of rated voltage for 2.5 minutes | | N/A |

| IEC 62368-1 | | | |
|-------------|--------------------|-----------------|---------|
| Clause | Requirement + Test | Result - Remark | Verdict |

| | | | |
|----------|---|-------------|-----|
| C2) | Test voltage | | — |
| D1) | 10,000 cycles on and off using capacitor with smallest capacitance resistor with largest resistance specified by manufacturer | | N/A |
| D2) | Capacitance | | — |
| D3) | Resistance | | — |
| H | CRITERIA FOR TELEPHONE RINGING SIGNALS | | N/A |
| H.1 | General | | N/A |
| H.2 | Method A | | N/A |
| H.3 | Method B | | N/A |
| H.3.1 | Ringing signal | | N/A |
| H.3.1.1 | Frequency (Hz) | | — |
| H.3.1.2 | Voltage (V) | | — |
| H.3.1.3 | Cadence; time (s) and voltage (V) | | — |
| H.3.1.4 | Single fault current (mA):..... | | — |
| H.3.2 | Tripping device and monitoring voltage | | N/A |
| H.3.2.1 | Conditions for use of a tripping device or a monitoring voltage complied with | | N/A |
| H.3.2.2 | Tripping device | | N/A |
| H.3.2.3 | Monitoring voltage (V) | | — |
| J | INSULATED WINDING WIRES FOR USE WITHOUT INTERLEAVED INSULATION | | P |
| | General requirements | UL approved | P |
| K | SAFETY INTERLOCKS | | N/A |
| K.1 | General requirements | | N/A |
| K.2 | Components of safety interlock safeguard mechanism | | N/A |
| K.3 | Inadvertent change of operating mode | | N/A |
| K.4 | Interlock safeguard override | | N/A |
| K.5 | Fail-safe | | N/A |
| | Compliance | | N/A |
| K.6 | Mechanically operated safety interlocks | | N/A |
| K.6.1 | Endurance requirement | | N/A |
| K.6.2 | Compliance and Test method | | N/A |
| K.7 | Interlock circuit isolation | | N/A |
| K.7.1 | Separation distance for contact gaps & interlock circuit elements (type and circuit location) | | N/A |
| K.7.2 | Overload test, Current (A) | | N/A |

| IEC 62368-1 | | | |
|--------------------|--------------------|-----------------|---------|
| Clause | Requirement + Test | Result - Remark | Verdict |

| | | | |
|------------|--|--|------------|
| K.7.3 | Endurance test | | N/A |
| K.7.4 | Electric strength test | | N/A |
| L | DISCONNECT DEVICES | | P |
| L.1 | General requirements | Appliance coupler for one type of open frame model series. Direct plug-in for other models. | P |
| L.2 | Permanently connected equipment | | N/A |
| L.3 | Parts that remain energized | | N/A |
| L.4 | Single phase equipment | | P |
| L.5 | Three-phase equipment | | N/A |
| L.6 | Switches as disconnect devices | | N/A |
| L.7 | Plugs as disconnect devices | | P |
| L.8 | Multiple power sources | | N/A |
| M | EQUIPMENT CONTAINING BATTERIES AND THEIR PROTECTION CIRCUITS | | N/A |
| M.1 | General requirements | | N/A |
| M.2 | Safety of batteries and their cells | | N/A |
| M.2.1 | Requirements | | N/A |
| M.2.2 | Compliance and test method (identify method) .. : | | N/A |
| M.3 | Protection circuits | | N/A |
| M.3.1 | Requirements | | N/A |
| M.3.2 | Tests | | N/A |
| | - Overcharging of a rechargeable battery | | N/A |
| | - Unintentional charging of a non-rechargeable battery | | N/A |
| | - Reverse charging of a rechargeable battery | | N/A |
| | - Excessive discharging rate for any battery | | N/A |
| M.3.3 | Compliance | | N/A |
| M.4 | Additional safeguards for equipment containing secondary lithium battery | | N/A |
| M.4.1 | General | | N/A |
| M.4.2 | Charging safeguards | | N/A |
| M.4.2.1 | Charging operating limits | | N/A |
| M.4.2.2a) | Charging voltage, current and temperature | | — |
| M.4.2.2 b) | Single faults in charging circuitry | | — |
| M.4.3 | Fire Enclosure | | N/A |

| IEC 62368-1 | | | |
|-------------|--------------------|-----------------|---------|
| Clause | Requirement + Test | Result - Remark | Verdict |

| | | | |
|---------|---|--|-----|
| M.4.4 | Endurance of equipment containing a secondary lithium battery | | N/A |
| M.4.4.2 | Preparation | | N/A |
| M.4.4.3 | Drop and charge/discharge function tests | | N/A |
| | Drop | | N/A |
| | Charge | | N/A |
| | Discharge | | N/A |
| M.4.4.4 | Charge-discharge cycle test | | N/A |
| M.4.4.5 | Result of charge-discharge cycle test | | N/A |
| M.5 | Risk of burn due to short circuit during carrying | | N/A |
| M.5.1 | Requirement | | N/A |
| M.5.2 | Compliance and Test Method (Test of P.2.3) | | N/A |
| M.6 | Prevention of short circuits and protection from other effects of electric current | | N/A |
| M.6.1 | Short circuits | | N/A |
| M.6.1.1 | General requirements | | N/A |
| M.6.1.2 | Test method to simulate an internal fault | | N/A |
| M.6.1.3 | Compliance (Specify M.6.1.2 or alternative method) | | N/A |
| M.6.2 | Leakage current (mA) | | N/A |
| M.7 | Risk of explosion from lead acid and NiCd batteries | | N/A |
| M.7.1 | Ventilation preventing explosive gas concentration | | N/A |
| M.7.2 | Compliance and test method | | N/A |
| M.8 | Protection against internal ignition from external spark sources of lead acid batteries | | N/A |
| M.8.1 | General requirements | | N/A |
| M.8.2 | Test method | | N/A |
| M.8.2.1 | General requirements | | N/A |
| M.8.2.2 | Estimation of hypothetical volume V_z (m ³ /s)..... | | — |
| M.8.2.3 | Correction factors..... | | — |
| M.8.2.4 | Calculation of distance d (mm) | | — |
| M.9 | Preventing electrolyte spillage | | N/A |
| M.9.1 | Protection from electrolyte spillage | | N/A |
| M.9.2 | Tray for preventing electrolyte spillage | | N/A |

| IEC 62368-1 | | | |
|--------------------|--------------------|-----------------|---------|
| Clause | Requirement + Test | Result - Remark | Verdict |

| | | | |
|----------|---|---------------------|-----|
| M.10 | Instructions to prevent reasonably foreseeable misuse (Determination of compliance: inspection, data review; or abnormal testing) | | N/A |
| N | ELECTROCHEMICAL POTENTIALS | | N/A |
| | Metal(s) used | | — |
| O | MEASUREMENT OF CREEPAGE DISTANCES AND CLEARANCES | | P |
| | Figures O.1 to O.20 of this Annex applied..... | O.5 | — |
| P | SAFEGUARDS AGAINST ENTRY OF FOREIGN OBJECTS AND SPILLAGE OF INTERNAL LIQUIDS | | P |
| P.1 | General requirements | | P |
| P.2.2 | Safeguards against entry of foreign object | | P |
| | Location and Dimensions (mm) | No openings | — |
| P.2.3 | Safeguard against the consequences of entry of foreign object | | N/A |
| P.2.3.1 | Safeguards against the entry of a foreign object | | N/A |
| | Openings in transportable equipment | | N/A |
| | Transportable equipment with metalized plastic parts | | N/A |
| P.2.3.2 | Openings in transportable equipment in relation to metallized parts of a barrier or enclosure (identification of supplementary safeguard) | | N/A |
| P.3 | Safeguards against spillage of internal liquids | No internal liquids | N/A |
| P.3.1 | General requirements | | N/A |
| P.3.2 | Determination of spillage consequences | | N/A |
| P.3.3 | Spillage safeguards | | N/A |
| P.3.4 | Safeguards effectiveness | | N/A |
| P.4 | Metallized coatings and adhesive securing parts | | N/A |
| P.4.2 a) | Conditioning testing | | N/A |
| | Tc (°C)..... | | — |
| | Tr (°C) | | — |
| | Ta (°C)..... | | — |
| P.4.2 b) | Abrasion testing | (See G.13.6.2) | N/A |
| P.4.2 c) | Mechanical strength testing | (See Annex T) | N/A |
| Q | CIRCUITS INTENDED FOR INTERCONNECTION WITH BUILDING WIRING | | N/A |
| Q.1 | Limited power sources | | N/A |
| Q.1.1 a) | Inherently limited output | | N/A |
| Q.1.1 b) | Impedance limited output | | N/A |

| IEC 62368-1 | | | |
|--------------------|--|-------------------------|---------|
| Clause | Requirement + Test | Result - Remark | Verdict |
| | - Regulating network limited output under normal operating and simulated single fault condition | | N/A |
| Q.1.1 c) | Overcurrent protective device limited output | | N/A |
| Q.1.1 d) | IC current limiter complying with G.9 | | N/A |
| Q.1.2 | Compliance and test method | | N/A |
| Q.2 | Test for external circuits – paired conductor cable | | N/A |
| | Maximum output current (A) | | — |
| | Current limiting method | | — |
| R | LIMITED SHORT CIRCUIT TEST | | N/A |
| R.1 | General requirements | | N/A |
| R.2 | Determination of the overcurrent protective device and circuit | | N/A |
| R.3 | Test method Supply voltage (V) and short-circuit current (A). | | N/A |
| S | TESTS FOR RESISTANCE TO HEAT AND FIRE | | N/A |
| S.1 | Flammability test for fire enclosures and fire barrier materials of equipment where the steady state power does not exceed 4 000 W | Approved materials used | N/A |
| | Samples, material | | — |
| | Wall thickness (mm)..... | | — |
| | Conditioning (°C)..... | | — |
| | Test flame according to IEC 60695-11-5 with conditions as set out | | N/A |
| | - Material not consumed completely | | N/A |
| | - Material extinguishes within 30s | | N/A |
| | - No burning of layer or wrapping tissue | | N/A |
| S.2 | Flammability test for fire enclosure and fire barrier integrity | | N/A |
| | Samples, material | | — |
| | Wall thickness (mm)..... | | — |
| | Conditioning (°C)..... | | — |
| | Test flame according to IEC 60695-11-5 with conditions as set out | | N/A |
| | Test specimen does not show any additional hole | | N/A |
| S.3 | Flammability test for the bottom of a fire enclosure | | N/A |
| | Samples, material | | — |
| | Wall thickness (mm)..... | | — |

| IEC 62368-1 | | | |
|--------------------|--------------------|-----------------|---------|
| Clause | Requirement + Test | Result - Remark | Verdict |

| | | | |
|----------|--|--------------------------|------------|
| | Cheesecloth did not ignite | | N/A |
| S.4 | Flammability classification of materials | | N/A |
| S.5 | Flammability test for fire enclosures and fire barrier materials of equipment where the steady state power does not exceed 4 000 W | | N/A |
| | Samples, material | | — |
| | Wall thickness (mm)..... | | — |
| | Conditioning (test condition), (°C)..... | | — |
| | Test flame according to IEC 60695-11-20 with conditions as set out | | N/A |
| | After every test specimen was not consumed completely | | N/A |
| | After fifth flame application, flame extinguished within 1 min | | N/A |
| T | MECHANICAL STRENGTH TESTS | | P |
| T.1 | General requirements | | P |
| T.2 | Steady force test, 10 N | (See appended table T.2) | P |
| T.3 | Steady force test, 30 N | (See appended table T3) | P |
| T.4 | Steady force test, 100 N | (See appended table T4) | P |
| T.5 | Steady force test, 250 N | | N/A |
| T.6 | Enclosure impact test | | N/A |
| | Fall test | | N/A |
| | Swing test | | N/A |
| T.7 | Drop test | (See appended table T7) | P |
| T.8 | Stress relief test | (See appended table T8) | P |
| T.9 | Impact Test (glass) | | N/A |
| T.9.1 | General requirements | | N/A |
| T.9.2 | Impact test and compliance | | N/A |
| | Impact energy (J)..... | | — |
| | Height (m) | | — |
| T.10 | Glass fragmentation test | (See sub-clause 4.4.4.9) | N/A |
| T.11 | Test for telescoping or rod antennas | | N/A |
| | Torque value (Nm) | | — |
| U | MECHANICAL STRENGTH OF CATHODE RAY TUBES (CRT) AND PROTECTION AGAINST THE EFFECTS OF IMPLOSION | | N/A |
| U.1 | General requirements | | N/A |

| IEC 62368-1 | | | |
|-------------|--------------------|-----------------|---------|
| Clause | Requirement + Test | Result - Remark | Verdict |

| | | | |
|----------|---|----------------------------------|-----|
| U.2 | Compliance and test method for non-intrinsically protected CRTs | | N/A |
| U.3 | Protective Screen.....: | (See Annex T) | N/A |
| V | DETERMINATION OF ACCESSIBLE PARTS (FINGERS, PROBES AND WEDGES) | | P |
| V.1 | Accessible parts of equipment | External enclosure & output wire | P |
| V.2 | Accessible part criterion | | P |

| IEC 62368-1 | | | |
|-------------|--------------------|-----------------|---------|
| Clause | Requirement + Test | Result - Remark | Verdict |

| 4.1.2 | TABLE: List of critical components | | | | | P |
|----------------------------|---|---------------------------|------------------------------------|---|---------------------------------------|---|
| Object / part No. | Manufacturer/ trademark | Type / model | Technical data | Standard | Mark(s) of conformity ¹ | |
| Enclosure & Blade holder | SABIC INNOVATIVE PLASTICS B V | SE1X SE1 945 | Min. V-1 at 1.5 mm thickness | IEC/EN 62368-1 UL 94 UL 746 A/B/C/D | Tested with appliance UL E45329 | |
| Alt. | SABIC INNOVATIVE PLASTICS B V | SE100 | Min. V-1 at 2.0 mm thickness | IEC/EN 62368-1 UL 94 UL 746 A/B/C/D | Tested with appliance UL E45329 | |
| Alt. | SABIC INNOVATIVE PLASTICS B V | C2950 CX7211 EXCY0098 940 | Min. V-0 at 2.0 mm thickness | IEC/EN 62368-1 UL 94 UL 746 A/B/C/D | Tested with appliance UL E45329 | |
| Alt. | TEIJIN CHEMICALS LTD | LN-1250P LN-1250G | Min. V-0 at 2.0 mm thickness | IEC/EN 62368-1 UL 94 UL 746 A/B/C/D | Tested with appliance UL E50075 | |
| Alt. | CHI MEI Corporation | PA-765A | Min. V-1 at 2.0 mm thickness | IEC/EN 62368-1 UL 94 UL 746 A/B/C/D | Tested with appliance UL E56070 | |
| Alt. | CHI MEI Corporation | PC-540 | Min. V-0 at 2.0 mm thickness | IEC/EN 62368-1 UL 94 UL 746 A/B/C/D | Tested with appliance UL E56070 | |
| AC inlet for Class I model | Zhejiang LECI Electronics Co., Ltd. | DB-6 | 2.5A, 250Vac Standard sheet: C6 | IEC/EN 60320-1 UL 498 | VDE 40032465 UL E302229 | |
| Alt. | Rich Bay Co., Ltd. | R-30790 R-307 | 2.5A, 250Vac Standard sheet: C6 | IEC/EN 60320-1 UL 498 | VDE 40030381 UL E184638 | |
| Alt. | Sun Fair Electric Wire & Cable (HK)Co. Ltd. | S-02 | 2.5A, 250Vac Standard sheet: C6 | IEC/EN 60320-1 UL 498 | VDE 40034448 UL E226643 | |
| Alt. | TECX-UNIONS Technology Corporation | TU-333 series | 2.5A, 250Vac Standard sheet: C6 | IEC/EN 60320-1 UL 498 | VDE 40005430 UL E100004 | |
| Alt. | Rong Feng Industrial Co., Ltd. | RF-190 | 2.5A, 250Vac Standard sheet: C6 | IEC/EN 60320-1 UL 498 | VDE 40030379 UL E102641 | |
| Alt. | Inalways Corporation | 0724 | 2.5A, 250Vac Standard sheet: C6 | IEC/EN 60320-1 UL 498 | ENEC 2010080 UL E94191 | |
| Alt. | Kunshan Dik Electronics Technology Co., Ltd | CDJ-2 | 2.5A, 250Vac Standard sheet: C6 | IEC/EN 60320-1 UL 498 | VDE 40022871 UL E317189 | |
| Alt. | Zhejiang LECI Electronics Co., Ltd. | DB-14 | 10A, 250Vac Standard sheet: C14 | IEC/EN 60320-1 UL 498 | VDE 40032137 UL E302229 | |

| IEC 62368-1 | | | | | |
|--|--|----------------------------|---------------------------------------|--------------------------|--|
| Clause | Requirement + Test | | Result - Remark | | Verdict |
| Alt. | Rich Bay Co., Ltd. | R-301SN | 10A, 250Vac Standard sheet: C14 | IEC/EN 60320-1 UL 498 | VDE 40030228 UL E184638 |
| Alt. | Sun Fair Electric Wire & Cable (HK)Co. Ltd. | S-03 | 10A, 250Vac Standard sheet: C14 | IEC/EN 60320-1 UL 498 | VDE 40034447 UL E226643 |
| Alt. | TECX-UNIONS Technology Corporation | TU-301-S TU-301-SP | 10A, 250Vac Standard sheet: C14 | IEC/EN 60320-1 UL 498 | VDE 40025582 UL E220004 |
| Alt. | Rong Feng Industrial Co., Ltd. | SS-120 | 10A, 250Vac Standard sheet: C14 | IEC/EN 60320-1 UL 498 | VDE 40028101 UL E102641 |
| Alt. | Inalways Corporation | 0711 series | 10A, 250Vac Standard sheet: C14 | IEC/EN 60320-1 UL 498 | ENEC 2010084 UL E94191 |
| AC inlet for Class II model | Zhejiang LECI Electronics Co., Ltd. | DB-8 | 2.5A, 250Vac Standard sheet: C8 | IEC/EN 60320-1 UL 498 | VDE 40032028 UL E302229 |
| Alt. | Rich Bay Co., Ltd. | R-201SN90 | 2.5A, 250Vac Standard sheet: C8 | IEC/EN 60320-1 UL 498 | VDE 40030384 UL E184638 |
| Alt. | Sun Fair Electric Wire & Cable (HK)Co. Ltd. | S-01 | 2.5A, 250Vac Standard sheet: C8 | IEC/EN 60320-1 UL 498 | VDE 40034449 UL E226643 |
| Alt. | TECX-UNIONS Technology Corporation | SO-222 series | 2.5A, 250Vac Standard sheet: C8 | IEC/EN 60320-1 UL 498 | VDE 40020337 UL E100004 |
| Alt. | Rong Feng Industrial Co., Ltd. | RF-180 | 2.5A, 250Vac Standard sheet: C8 | IEC/EN 60320-1 UL 498 | VDE 40030168 UL E102641 |
| Alt. | Inalways Corporation | 0721 series | 2.5A, 250Vac Standard sheet: C8 | IEC/EN 60320-1 UL 498 | ENEC 2010087 UL E94191 |
| Alt. | Kunshan Dik Electronics Technology Co., Ltd | CDJ-8 | 2.5A, 250Vac Standard sheet: C8 | IEC/EN 60320-1 UL 498 | VDE 40025531 UL E317189 |
| Insulating tube used on appliance inlet | SHENZHEN WOER HEAT- SHRINKABLE MATERIAL CO LTD | RSFR RSFR-H RSFR-HPF | 600V, 125°C | IEC/EN 62368-1 UL 224 | Tested within appliance UL E203950 |
| Alt. | QIFURUI ELECTRONICS CO | QFR-h | 600V, 125°C | IEC/EN 62368-1 UL 224 | Tested within appliance UL E225897 |

| IEC 62368-1 | | | | | |
|-------------------------|--|--------------------------------------|------------------------------------|--------------------------|---------------------------------------|
| Clause | Requirement + Test | | Result - Remark | | Verdict |
| Alt. | DONGGUAN SALIPT CO LTD | SALIPT S-901-300 SALIPT S-901-600 | Min. 300V, 125°C | IEC/EN 62368-1 UL 224 | Tested within appliance UL E209436 |
| Alt. | GUANGZHOU KAIHENG ENTERPRISE GROUP | K-2 (+) K-2 (CB) | Min. 300V, 125°C | IEC/EN 62368-1 UL 224 | Tested within appliance UL E214175 |
| Alt. | CHANGYUAN ELECTRONICS (SHENZHEN) CO LTD | CB-HFT | Min. 300V, 125°C | IEC/EN 62368-1 UL 224 | Tested within appliance UL E180908 |
| Alt. | SHENZHEN WOLIDA TRADING CO LTD | RSFR-H | 600V, 125°C | IEC/EN 62368-1 UL 224 | Tested within appliance E329530 |
| Internal primary wiring | DONGGUAN YUE YANG WIRE & CABLE CO LTD | 1007, 1015, 1185, 2464, 2468 | Min. 18AWG, min. 300Vac, min. 80°C | IEC/EN 62368-1 UL 758 | Tested with appliance UL E230810 |
| Alt. | YONG HAO ELECTRICAL INDUSTRY CO LTD | 1007, 1015, 1185, 2464, 2468 | Min. 18AWG, min. 300Vac, min. 80°C | IEC/EN 62368-1 UL 758 | Tested with appliance UL E240426 |
| Alt. | HIP TAI ELECTRIC WIRE CO | 1007, 1015, 1185, 2464, 2468 | Min. 18AWG, min. 300Vac, min. 80°C | IEC/EN 62368-1 UL 758 | Tested with appliance UL E225804 |
| Alt. | KUNSHAN NEW ZHICHENG ELECTRONICS TECHNOLOGIES CO LTD | 1007, 1015, 1185, 2464, 2468 | Min. 18AWG, min. 300Vac, min. 80°C | IEC/EN 62368-1 UL 758 | Tested with appliance UL E237831 |
| Alt. | SHENG YU ENTERPRISE CO LTD | 1007, 1015, 2464, 2468 | Min. 18AWG, min. 300Vac, min. 80°C | IEC/EN 62368-1 UL 758 | Tested with appliance UL E219726 |
| Alt. | SUZHOU YEMAO ELECTRONIC CO LTD | 1007, 1015, 1185, 2464, 2468 | Min. 18AWG, min. 300Vac, min. 80°C | IEC/EN 62368-1 UL 758 | Tested with appliance UL E353532 |
| Alt. | SUZHOU HONGMENG ELECTRONIC CO LTD | 1007, 1015, 1185, 2464, 2468 | Min. 18AWG, min. 300Vac, min. 80°C | IEC/EN 62368-1 UL 758 | Tested with appliance UL E315421 |
| Alt. | ZHUANG SHAN CHUAN ELECTRICAL PRODUCTS (KUNSHAN) CO LTD | 1007, 1015, 1185, 2464, 2468 | Min. 18AWG, min. 300Vac, min. 80°C | IEC/EN 62368-1 UL 758 | Tested with appliance UL E333601 |

| IEC 62368-1 | | | | | |
|--|---|---|---------------------------------------|---|---------------------------------------|
| Clause | Requirement + Test | | Result - Remark | | Verdict |
| Alt. | SUZHOU QCTECH CO LTD | 1007, 1015, 1185, 2464, 2468 | Min. 18AWG, min. 300Vac, min. 80°C | IEC/EN 62368-1 UL 758 | Tested with appliance E322968 |
| Insulating sheet only for GT-41134-0606-W2-TAB | FORMEX, DIV OF IL TOOL WORKS INC, FRMRLY FASTEX, DIV OF IL TOOL WORKS INC | FORMEX GK series | V-0, min. 0.4 mm thickness, 115°C | IEC/EN 62368-1 UL 94 UL 746 A/B/C/D | Tested with appliance UL E121855 |
| Alt. | MIANYANG LONGHUA FILM CO LTD | PP-WT-20 | VTM-0, min. 0.4 mm thickness, 65°C | IEC/EN 62368-1 UL 94 UL 746 A/B/C/D | Tested with appliance UL E254551 |
| Alt. | SKC CO LTD | SH71S | VTM-2, min. 0.4 mm thickness, 105°C | IEC/EN 62368-1 UL 94 UL 746 A/B/C/D | Tested with appliance UL E74359 |
| Alt. | TORAY INDUSTRIES INC | Lumirror H10 | VTM-2, min. 0.4 mm thickness, 105°C | IEC/EN 62368-1 UL 94 UL 746 A/B/C/D | Tested with appliance UL E86511 |
| Alt. | SABIC INNOVATIVE PLASTICS US L L C | FR60 series FR63 series FR65 series FR7 series FR700 series | V-0, min. 0.4 mm thickness, 130°C | IEC/EN 62368-1 UL 94 UL 746 A/B/C/D | Tested with appliance UL E121562 |
| Alt. | MIANYANG LONGHUA FILM CO LTD | PP-BK series PP-WT series | V-0, min. 0.4 mm thickness, 80°C | IEC/EN 62368-1 UL 94 UL 746 A/B/C/D | Tested with appliance UL E254551 |
| Alt. | ITW ELECTRONICS COMPONENTS/ PRODUCTS (SHANGHAI) CO LTD | FORMEX-18 FORMEX-17 | V-0, min. 0.4 mm thickness, 100°C | IEC/EN 62368-1 UL 94 UL 746 A/B/C/D | Tested within appliance UL E256266 |
| PCB | TECHNI TECHNOLOGY LTD | T2A T2B T4 | Min. V-0, min 1.6 mm thickness, 130°C | IEC/EN 62368-1 UL 796 | Tested with appliance UL E154355 |
| Alt. | DONGGUAN HE TONG ELECTRONICS CO LTD | CEM1 2V0 FR4 | Min. V-0, min 1.6 mm thickness, 130°C | IEC/EN 62368-1 UL 796 | Tested with appliance UL E243157 |
| Alt. | CHEERFUL ELECTRONIC | 03 03A | Min. V-0, min 1.6 mm thickness, 130°C | IEC/EN 62368-1 UL 796 | Tested with appliance UL E199724 |
| Alt. | DONGGUAN DAYSUN ELECTRONIC CO LTD | DS2 | Min. V-0, min 1.6 mm thickness, 130°C | IEC/EN 62368-1 UL 796 | Tested with appliance UL E251754 |

| IEC 62368-1 | | | | | |
|---|--|--------------------|--|-----------------------------------|------------------------------------|
| Clause | Requirement + Test | | Result - Remark | | Verdict |
| Alt. | SUZHOU CITY YILIHUA ELECTRONICS CO LTD | YLH-1 | Min. V-0, min 1.6 mm thickness, 130°C | IEC/EN 62368-1 UL 796 | Tested with appliance UL E251781 |
| Alt. | SHANGHAI AREX PRECISION ELECTRONIC CO LTD | 02V0 04V0 | Min. V-0, min 1.6 mm thickness, 130°C | IEC/EN 62368-1 UL 796 | Tested with appliance UL E186016 |
| Alt. | BRITE PLUS ELECTRONICS (SUZHOU) CO LTD | DKV0-3A DGV0-3A | Min. V-0, min 1.6 mm thickness, 130°C | IEC/EN 62368-1 UL 796 | Tested with appliance UL E177671 |
| Alt. | KUOTIANG ENT LTD | C-2 C-2A | Min. V-0, min 1.6 mm thickness, 130°C | IEC/EN 62368-1 UL 796 | Tested with appliance UL E227299 |
| Alt. | PACIFIC WIN INDUSTRIAL LTD | PW-02 PW-03 | Min. V-0, min 1.6 mm thickness, 130°C | IEC/EN 62368-1 UL 796 | Tested with appliance UL E228070 |
| Alt. | SHENZHEN TONGCHUANGXI N ELECTRONICS CO LTD | TCX | Min. V-0, min 1.6 mm thickness, 130°C | IEC/EN 62368-1 UL 796 | Tested with appliance UL E250336 |
| Alt. | Interchangeable | Interchangeable | Min. V-0, min 1.6 mm thickness, 130°C | IEC/EN 62368-1 UL 796: 2010 | Tested with appliance UL Approved. |
| Fuse (F1, F2) ³ (F2 is optional.) | Conquer Electronics Co., Ltd. | MST | T1A or T6.3A, 250V, Rated breaking capacity 100A | IEC/EN 60127-2 UL 248-1 UL 248-14 | VDE 40017118 UL E82636 |
| Alt. | Ever Island Electric Co., Ltd. and Walter Electric | 2010 | T1A or T6.3A, 250V, Rated breaking capacity 130A | IEC/EN 60127-2 UL 248-1 UL 248-14 | VDE 40018781 UL E220181 |
| Alt. | Bel Fuse Ltd. | RST | T1A or T6.3A, 250V, Rated breaking capacity 100A | IEC/EN 60127-2 UL 248-1 UL 248-14 | VDE 40011144 UL E20624 |
| Alt. | Cooper Bussmann LLC | SS-5 | T1A or T6.3A, 250V, Rated breaking capacity 35A | IEC/EN 60127-2 UL 248-1 UL 248-14 | VDE 40015513 UL E19180 |
| Alt. | Das & Sons International Ltd. | 385T series | T1A or T6.3A, 250V, Rated breaking capacity 35A | IEC/EN 60127-2 UL 248-1 UL 248-14 | VDE 40008524 UL E205718 |

| IEC 62368-1 | | | | | |
|-----------------------------------|--|---------------|--|---|--|
| Clause | Requirement + Test | | Result - Remark | | Verdict |
| Alt. | | SMT | T1A or T6.3A, 250V, Rated breaking capacity 35A | IEC/EN 60127-2 UL 248-1 UL 248-14 | VDE 40012592 UL E221465 |
| Alt. | Walter Electronic Co. Ltd. | ICP series | T1A or T6.3A, 250V, Rated breaking capacity 50A. | IEC/EN 60127-2 UL 248-1 UL 248-14 | VDE 40012824 UL E56092 |
| Alt. | Zhongshan Lanbao Electrical Appliances Co., Ltd. | RTI-10 series | T1A or T6.3A, 250V, Rated breaking capacity 50A | IEC/EN 60127-2 UL 248-1 UL 248-14 | VDE 40017009 UL E213695 |
| Alt. | Sun Electric Co. | 5T | T1A or T6.3A, 250V, Rated breaking capacity 100A | IEC/EN 60127-2 UL 248-1 UL 248-14 | VDE 40027241 UL E166522 |
| Alt. | Bel Fuse Ltd. | 5ST | T1A or T6.3A, 250V, Rated breaking capacity 35A | IEC/EN 60127-2 UL 248-1 UL 248-14 | VDE 40000507 UL E20624 |
| Y-Capacitor (CY1, CY2) (optional) | SUCCESS ELECTRONICS CO LTD | SE SB | Type Y1, max. 470pF, min. 250V, 125°C | IEC/EN 60384-14 UL 60384-14 UL 1414 | VDE 40037221 VDE 40037211 UL E114280 |
| Alt. | MURATA MFG CO LTD | KX | Type Y1, max. 470pF, min. 250V, 125°C | IEC/EN 60384-14 UL 60384-14 UL 1414 | VDE 40002831 UL E37921 |
| Alt. | WALSIN TECHNOLOGY CORP | AH | Type Y1, max. 470pF, min. 250V, 125°C | IEC/EN 60384-14 UL 60384-14 UL 1414 | VDE 40001804 UL E146544 |
| Alt. | JYA-NAY CO LTD | JN | Type Y1, max. 470pF, min. 250V, 125°C | IEC/EN 60384-14 UL 60384-14 UL 1414 | VDE 40001831 UL E201384 |
| Alt. | HAOHUA ELECTRONIC CO | CT7 | Type Y1, max. 470pF, min. 250V, 125°C | IEC/EN 60384-14 UL 60384-14 UL 1414 | VDE 40003902 UL E233106 |
| Alt. | JERRO ELECTRONICS CORP | JX-series | Type Y1, max. 470pF, min. 250V, 125°C | IEC/EN 60384-14 UL 60384-14 UL 1414 | VDE 40032158 UL E333001 |
| Alt. | TDK CORP | CD | Type Y1, max. 470pF, min. 250V, 125°C | IEC/EN 60384-14 UL 60384-14 UL 1414 | VDE 124321 UL E37861 |
| Alt. | JYH CHUNG ELECTRONICS CO LTD | JD | Type Y1, max. 470pF, min. 250V, 125°C | IEC/EN 60384-14 UL 60384-14 UL 1414 | VDE 137027 UL E187963 |

| IEC 62368-1 | | | | | |
|--|--|----------------------------|---|---|----------------------------|
| Clause | Requirement + Test | | Result - Remark | | Verdict |
| Alt. | WELSON INDUSTRIAL CO LTD | WD | Type Y1, max. 470pF, min. 250V, 125°C | IEC/EN 60384-14 UL 60384-14 UL 1414 | VDE 115455 UL E104572 |
| Varistor (MOV1) (optional) | JOYIN CO LTD | 10N471K 14N471K | Max continuous voltage: 300VAC, 6kV/3kA, 40/85/56 | IEC 61051-2 UL 1449 | VDE 005937 UL E325508 |
| Alt. | CENTRA SCIENCE CORP | 10D471K 14D471K | Max continuous voltage: 300VAC, 6kV/3kA, 40/85/56 | IEC 61051-2 UL 1449 | VDE 40008220 UL E316325 |
| Alt. | THINKING ELECTRONIC INDUSTRIAL CO LTD | TVR10471K TVR14471K | Max continuous voltage: 300VAC, 6kV/3kA, 40/85/56 | IEC 61051-2 UL 1449 | VDE 005944 UL E314979 |
| Alt. | SUCCESS ELECTRONICS CO LTD | SVR10D471K SVR14D471K | Max continuous voltage: 300VAC, 6kV/3kA, 40/85/56 | IEC 61051-2 UL 1449 | VDE 40030401 UL E330256 |
| Alt. | CERAMATE TECHNICAL CO LTD | GNR10D471K GND14D471K | Max continuous voltage: 300VAC, 6kV/3kA, 40/85/56 | IEC 61051-2 UL 1449 | VDE 40031745 UL E315429 |
| Alt. | BRIGHTKING (SHENZHEN) CO LTD | 10D471K 14D471K | Max continuous voltage: 300VAC, 6kV/3kA, 40/85/56 | IEC 61051-2 UL 1449 | VDE 40027827 UL E327997 |
| Alt. | LIEN SHUN ELECTRONICS CO LTD | 10D471K 14D471K | Max continuous voltage: 300VAC, 6kV/3kA, 40/85/56 | IEC 61051-2 UL 1449 | VDE 40005858 UL E315524 |
| Alt. | HONGZHI ENTERPRISES LTD | HEL-10D471K HEL-14D471K | Max continuous voltage: 300VAC, 6kV/3kA, 40/85/56 | IEC 61051-2 UL 1449 | VDE 40008621 UL E324904 |
| Alt. | GUANGXI NEW FUTURE INFORMATION INDUSTRY CO LTD | 10D471K 14D471K | Max continuous voltage: 300VAC, 6kV/3kA, 40/85/56 | IEC 61051-2 UL 1449 | VDE 40030322 UL E323753 |
| Varistor (MOV1) (optional) (only for GT-41134-0606-W2-TAB) | Panasonic Corporation | ERZV20D241 (V20241U) | Max continuous voltage: 150VAC, 6kV/3kA, 40/85/56 | IEC 61051-2 UL 1449 | VDE 40018677 UL E321499 |
| Alt. | Brightking (Shenzhen) Co., Ltd. | 241KD20J | Max continuous voltage: 150VAC, 6kV/3kA, 40/85/56 | IEC 61051-2 UL 1449 | VDE 40027827 UL E327997 |
| Alt. | EPCOS | S20K150 | Max continuous voltage: 150VAC, 6kV/3kA, 40/85/56 | IEC 61051-2 UL 1449 | VDE 40027582 UL E321126 |
| Alt. | Thinking Electronic Industrial Co., Ltd. | TVR20241K | Max continuous voltage: 150VAC, 6kV/3kA, 40/85/56 | IEC 61051-2 UL 1449 | VDE 005944 UL E314979 |

| IEC 62368-1 | | | | | |
|------------------------|---|--|---|---------------------------|-------------------------------------|
| Clause | Requirement + Test | | Result - Remark | Verdict | |
| Alt. | Success Electronics Co., Ltd. | SVR20D241K | Max continuous voltage: 150VAC, 6kV/3kA, 40/85/56 | IEC 61051-2 UL 1449 | VDE 40030401 UL E330256 |
| Transformer (T1) | /GlobTek/ BOAM/ HAOPUWEI | XF00716I for 3.3-4.9V XF00714I for 5-8.9V XF00717 for 9-14.9V XF00718 for 15-18.9V XF00719 for 19-24V XF00814 for 24.1-36V XF00841 for 36.1-48V TF032 for 5-8.9V TF033 for 9-14.9V TF034 for 15-18.9V TF035 for 19-24V | Class B, with critical component listed below | IEC/EN 62368-1 | Tested with appliance |
| -Insulation system | | 130-1 | Class 130(B) | IEC/EN 62368-1 UL 1446 | Tested with appliance UL E308897 |
| -Alt. | GLOBTEK INC | GTX-130-TM | Class 130(B) | IEC/EN 62368-1 UL 1446 | Tested with appliance UL E243347 |
| -Alt. | SHAN DONG BOAM ELECTRIC CO LTD | BOAM-01 | Class 130(B) | IEC/EN 62368-1 UL 1446 | Tested with appliance UL E252329 |
| -Alt. | WUXI HAOPUWEI ELECTRONICS CO LTD | ZT-130 | Class 130(B) | IEC/EN 62368-1 UL 1446 | Tested with appliance UL E315275 |
| -Magnet wire (Primary) | PACIFIC ELECTRIC WIRE & CABLE (SHENZHEN) CO LTD | UEWN/U | 130°C | IEC/EN 62368-1 UL 1446 | Tested with appliance UL E201757 |
| -Alt. | JUNG SHING WIRE CO LTD | UEW-4 UEY-2 | 130°C | IEC/EN 62368-1 UL 1446 | Tested with appliance UL E174837 |

| IEC 62368-1 | | | | | |
|-----------------------------|---|------------------------|----------------------------------|--|----------------------------------|
| Clause | Requirement + Test | | | Result - Remark | Verdict |
| -Alt. | JIANGSU HONGLIU MAGNET WIRE TECHNOLOGY CO LTD | 2UEW/130 | 130°C | IEC/EN 62368-1 UL 1446 | Tested with appliance UL E335065 |
| -Alt. | CHANGZHOU DAYANG WIRE & CABLE CO LTD | 2UEW/130 | 130°C | IEC/EN 62368-1 UL 1446 | Tested with appliance UL E158909 |
| -Alt. | WUXI JUFENG COMPOUND LINE CO LTD | 2UEWB | 130°C | IEC/EN 62368-1 UL 1446 | Tested with appliance UL E206882 |
| -Alt. | JIANGSU DARTONG M & E CO LTD | UEW | 130°C | IEC/EN 62368-1 UL 1446 | Tested with appliance UL E237377 |
| -Alt. | SHANDONG SAINT ELECTRIC CO LTD | UEW/130 | 130°C | IEC/EN 62368-1 UL 1446 | Tested with appliance UL E194410 |
| -Alt. | ZHEJIANG LANGLI ELECTRIC EQUIPMENTS CO LTD | UEW | 130°C | IEC/EN 62368-1 UL 1446 | Tested with appliance UL E222214 |
| -Secondary wire of T1 (TIW) | GREAT LEOFロン INDUSTRIAL CO LTD | TRW (B) | Min.130°C | IEC/EN 62368-1 UL 2353 | Tested with appliance UL E211989 |
| -Alt. | COSMOLINK CO LTD | TIW-M | Min.130°C | IEC/EN 62368-1 UL 2353 | Tested with appliance UL E213764 |
| -Alt. | FURUKAWA ELECTRIC CO LTD | TEX-E | Min.130°C | IEC/EN 62368-1 UL 2353 | Tested with appliance UL E206440 |
| -Alt. | TOTOKU ELECTRIC CO LTD | TIW-2 | Min.130°C | IEC/EN 62368-1 UL 2353 | Tested with appliance UL E166483 |
| -Alt. | E&B TECHNOLOGY CO LTD | E&B-XXXB E&B-XXXB-1 | Min.130°C | IEC/EN 62368-1 UL 2353 | Tested with appliance UL E315265 |
| -Bobbin | CHANG CHUN PLASTICS CO LTD | T375J T375HF | V-0, 150°C, min thickness: 0.6mm | IEC/EN 62368-1 UL 94 UL 746 A/B/C/D | Tested with appliance UL E59481 |
| -Alt. | SUMITOMO BAKELITE CO LTD | PM-9820 | V-0, 150°C, min thickness: 0.6mm | IEC/EN 62368-1 UL 94 UL 746 A/B/C/D | Tested with appliance UL E41429 |
| -Alt. | HITACHI CHEMICAL CO LTD | CP-J-8800 | V-0, 150°C, min thickness: 0.6mm | IEC/EN 62368-1 UL 94 UL 746 A/B/C/D | Tested with appliance UL E42956 |

| IEC 62368-1 | | | | | |
|-------------|--------------------|--|--|-----------------|---------|
| Clause | Requirement + Test | | | Result - Remark | Verdict |

| | | | | | |
|------------------|--|--------------------|-------|--------------------------|--|
| -Insulating tape | 3M COMPANY ELECTRICAL MARKETS DIV (EMD) | 1350F-1 1350T-1 | 130°C | IEC/EN 62368-1 UL 510 | Tested with appliance UL E17385 |
| -Alt. | BONDTEC PACIFIC CO LTD | 370S | 130°C | IEC/EN 62368-1 UL 510 | Tested with appliance UL E175868 |
| -Alt. | JINGJIANG YAHUA PRESSURE SENSITIVE GLUE CO LTD | PZ CT WF | 130°C | IEC/EN 62368-1 UL 510 | Tested with appliance UL E165111 |
| -Alt. | JINGJIANG JINGYI ADHESIVE PRODUCT CO LTD | JY25-A | 130°C | IEC/EN 62368-1 UL 510 | Tested with appliance UL E246950 |
| -Alt. | CHANG SHU LIANG YI TAPE INDUSTRY CO LTD | LY-XX | 130°C | IEC/EN 62368-1 UL 510 | Tested with appliance UL E246820 |

Components listed below are not regarded as critical components:

| | | | | | |
|-------------|-----------------|-----------------|---------------------------------------|--------------|-------------|
| Output cord | Interchangeable | Interchangeable | Min. 24AWG, min. 300Vac, min. 80°C | UL 758: 2010 | UL approved |
|-------------|-----------------|-----------------|---------------------------------------|--------------|-------------|

Supplementary information:

- 1) Provided evidence ensures the agreed level of compliance. See OD-CB2039.
- 2) Description line content is optional. Main line description needs to clearly detail the component used for testing
- 3) For GT-41134-0606-W2-TAB, the fuse rating is T6.3A and evaluated separately. For the structure type only use F1 fuse, the fuse rating is T1A.

| IEC 62368-1 | | | |
|-------------|--------------------|-----------------|---------|
| Clause | Requirement + Test | Result - Remark | Verdict |

| 5.2 | | Table: Classification of electrical energy sources | | | | | P |
|---|----------------|--|------------------------|---------------------------|---|-------|----------|
| 5.2.2.2 – Steady State Voltage and Current conditions | | | | | | | |
| No. | Supply Voltage | Location (e.g. circuit designation) | Test conditions | Parameters | | | ES Class |
| | | | | U (Vrms or Vpk or Vdc) | I (A _{pk} or A _{rms}) | Hz | |
| 1 model: GTM41 134- 0603- *** | 264 | T1 sec. output | Normal | 28.4Vp | -- | <1kHz | ES1 |
| | | | Abnormal | 28.4Vp | -- | <1kHz | |
| | | | Single fault – SC/OC | -- | -- | -- | |
| 2 model: GTM41 134- 0606- 1.0-*** | 264 | C5 | Normal | 5.0Vdc | -- | -- | ES1 |
| | | | Abnormal | 5.0Vdc | -- | -- | |
| | | | Single fault – C5 (OC) | 5.0Vdc | -- | -- | |
| | | | Single fault – D6 (SC) | 0.2Vdc | -- | -- | |
| 3 model: GTM41 134- 0612- 3.0-*** | 264 | C5 | Normal | 9.0Vdc | -- | -- | ES1 |
| | | | Abnormal | 9.0Vdc | -- | -- | |
| | | | Single fault – C5 (OC) | 9.0Vdc | -- | -- | |
| | | | Single fault – D6 (SC) | 0.3Vdc | -- | -- | |
| 4 model: GTM41 134- 0648- *** | 264 | C5 | Normal | 49.0Vdc | -- | -- | ES1 |
| | | | Abnormal | 49.0Vdc | -- | -- | |
| | | | Single fault – C5 (OC) | 49.0Vdc | -- | -- | |
| | | | Single fault – D6 (SC) | 0.2Vdc | -- | -- | |
| 5 model: GTM96 060- 0603 | 264 | T1 sec. output | Normal | 28.4Vp | -- | <1kHz | ES1 |
| | | | Abnormal | 28.4Vp | -- | <1kHz | |
| | | | Single fault – SC/OC | -- | -- | -- | |

| IEC 62368-1 | | | | |
|-------------|--------------------|--|-----------------|---------|
| Clause | Requirement + Test | | Result - Remark | Verdict |

| | | | | | | | |
|--|-----|----|---------------------------|---------|----|----|-----|
| 6 model: GTM96 060- 0606- 1.0 | 264 | C5 | Normal | 5.0Vdc | -- | -- | ES1 |
| | | | Abnormal | 5.0Vdc | -- | -- | |
| | | | Single fault – C5 (OC) | 5.0Vdc | -- | -- | |
| | | | Single fault – D6 (SC) | 0.2Vdc | -- | -- | |
| 7 model: GTM96 060- 0648 | 264 | C5 | Normal | 49.0Vdc | -- | -- | ES1 |
| | | | Abnormal | 49.0Vdc | -- | -- | |
| | | | Single fault – C5 (OC) | 49.0Vdc | -- | -- | |
| | | | Single fault – D6 (SC) | 0.3Vdc | -- | -- | |

5.2.2.3 - Capacitance Limits

| No. | Supply Voltage | Location (e.g. circuit designation) | Test conditions | Parameters | | ES Class |
|-----|----------------|-------------------------------------|-------------------------|-----------------|---------|----------|
| | | | | Capacitance, nF | Upk (V) | |
| -- | -- | -- | Normal | -- | -- | -- |
| | | | Abnormal | -- | -- | |
| | | | Single fault – SC/OC | -- | -- | |

5.2.2.4 - Single Pulses

| No. | Supply Voltage | Location (e.g. circuit designation) | Test conditions | Parameters | | | ES Class |
|-----|----------------|-------------------------------------|-------------------------|---------------|---------|----------|----------|
| | | | | Duration (ms) | Upk (V) | Ipk (mA) | |
| -- | -- | -- | Normal | -- | -- | -- | -- |
| | | | Abnormal | -- | -- | -- | |
| | | | Single fault – SC/OC | -- | -- | -- | |

| IEC 62368-1 | | | |
|-------------|--------------------|-----------------|---------|
| Clause | Requirement + Test | Result - Remark | Verdict |

| 5.2.2.5 - Repetitive Pulses | | | | | | | |
|--|----------------|-------------------------------------|----------------------|---------------|---------|----------|----------|
| No. | Supply Voltage | Location (e.g. circuit designation) | Test conditions | Parameters | | | ES Class |
| | | | | Off time (ms) | Upk (V) | Ipk (mA) | |
| -- | -- | -- | Normal | -- | -- | -- | -- |
| | | | Abnormal | -- | -- | -- | |
| | | | Single fault – SC/OC | -- | -- | -- | |
| Test Conditions: Normal – Test with rated output current. Abnormal – Test with max. output current. Supplementary information: SC=Short Circuit, OC=Short Circuit | | | | | | | |

| IEC 62368-1 | | | |
|-------------|--------------------|-----------------|---------|
| Clause | Requirement + Test | Result - Remark | Verdict |

| 5.4.1.4, 6.3.2, 9.0, B.2.6 | TABLE: Temperature measurements | | | | | P |
|--|-------------------------------------|--------|--------|--------|--------|-------------------------------|
| | Supply voltage (V) | 90Vac | 264Vac | 108Vac | 132Vac | — |
| | Ambient T _{min} (°C) | 50 | 50 | 50 | 50 | — |
| | Ambient T _{max} (°C) | 50 | 50 | 50 | 50 | — |
| | T _{ma} (°C) | 50 | 50 | 50 | 50 | — |
| Maximum measured temperature T of part/at: | | T (°C) | | | | Allowed T _{max} (°C) |
| Model GTM41134-0603 (Horizontal) due to highest measured power consumption | | | | | | |
| Enclosure (external surface) | 57.3 | 56.8 | -- | -- | 77 | |
| Enclosure (internal surface) | 75.2 | 74.5 | -- | -- | -- | |
| Fuse nearby PCB | 50.8 | 50.2 | -- | -- | 130 | |
| PCB near D1 | 60.0 | 59.6 | -- | -- | 130 | |
| C1 body | 69.4 | 68.7 | -- | -- | 105 | |
| PCB near Q1 | 91.5 | 91.0 | -- | -- | 130 | |
| T1 winding | 83.7 | 83.1 | -- | -- | *110 | |
| PCB near U1 | 67.6 | 66.9 | -- | -- | 130 | |
| Enclosure (external surface) | 57.3 | 56.8 | -- | -- | 77 | |
| Model GTM41134-0606-1.0-F | | | | | | |
| PCB near D1 | 60.0 | 56.5 | -- | -- | 130 | |
| C1 | 56.8 | 51.4 | -- | -- | 105 | |
| PCB near Q1 | 63.5 | 62.0 | -- | -- | 130 | |
| T1 winding | 71.7 | 69.2 | -- | -- | *110 | |
| T1 bobbin | 74.7 | 72.0 | -- | -- | *110 | |
| PCB near U1 | 55.4 | 53.5 | -- | -- | 130 | |
| Model GT-41134-0606-W2-TAB (Horizontal) due to worst position | | | | | | |
| T1 winding | -- | -- | 105.3 | 104.3 | *110 | |
| T1 core | -- | -- | 102.3 | 101.1 | *110 | |
| C2 | -- | -- | 89.9 | 88.1 | 105 | |
| C6 | -- | -- | 82.0 | 82.0 | 105 | |
| PCB near F1 | -- | -- | 56.2 | 55.5 | 130 | |
| PCB near Q1 | -- | -- | 89.0 | 87.8 | 130 | |
| Enclosure (external surface) | -- | -- | 65.3 | 65.6 | 77 | |
| Model GTM96060-0603 | | | | | | |
| T1 winding | 93.1 | 93.0 | -- | -- | *110 | |

| IEC 62368-1 | | | | | |
|-------------|--------------------|--|-----------------|--|---------|
| Clause | Requirement + Test | | Result - Remark | | Verdict |

| | | | | | |
|--------------------|------|------|----|----|------|
| T1 core | 95.3 | 97.4 | -- | -- | *110 |
| Varistor | 76.5 | 73.1 | -- | -- | 85 |
| CY1 | 79.3 | 78.3 | -- | -- | 85 |
| PCB | 89.7 | 88.2 | -- | -- | 130 |
| External enclosure | 67.8 | 66.3 | -- | -- | 77 |
| Output cord | 64.9 | 63.4 | -- | -- | 80 |

Model GTM96060-0606-1.0

| | | | | | |
|--------------------|------|------|----|----|------|
| T1 winding | 96.1 | 97.5 | -- | -- | *110 |
| T1 core | 95.2 | 97.7 | -- | -- | *110 |
| Varistor | 72.0 | 69.3 | -- | -- | 85 |
| CY1 | 75.5 | 74.8 | -- | -- | 85 |
| PCB | 79.7 | 78.9 | -- | -- | 130 |
| External enclosure | 68.8 | 68.0 | -- | -- | 77 |
| Output cord | 64.6 | 63.2 | -- | -- | 80 |

Model GTM96060-0648

| | | | | | |
|--------------------|------|------|----|----|------|
| T1 winding | 94.4 | 95.1 | -- | -- | *110 |
| T1 core | 91.3 | 93.2 | -- | -- | *110 |
| Varistor | 69.5 | 66.6 | -- | -- | 85 |
| CY1 | 71.7 | 70.3 | -- | -- | 85 |
| PCB | 78.5 | 78.5 | -- | -- | 130 |
| External enclosure | 65.8 | 65.4 | -- | -- | 77 |
| Output cord | 64.9 | 63.1 | -- | -- | 80 |

Supplementary information:

*: as the temperature of winding was measured by thermocouples, the limit value was reduced by 10°C.

| Temperature T of winding: | t ₁ (°C) | R ₁ (Ω) | t ₂ (°C) | R ₂ (Ω) | T (°C) | Allowed T _{max} (°C) | Insulation class |
|---------------------------|---------------------|--------------------|---------------------|--------------------|--------|-------------------------------|------------------|
| -- | -- | -- | -- | -- | -- | -- | -- |
| -- | -- | -- | -- | -- | -- | -- | -- |

Supplementary information:

Note 1: T_{ma} should be considered as directed by applicable requirement

Note 2: T_{ma} is not included in assessment of Touch Temperatures (Clause 9)

| IEC 62368-1 | | | |
|-------------|--------------------|-----------------|---------|
| Clause | Requirement + Test | Result - Remark | Verdict |

| 5.4.1.10.3 | TABLE: Ball pressure test of thermoplastics | | | P |
|---|---|-----------------------|--------------------------|---|
| Allowed impression diameter (mm) : ≤ 2 mm | | | | — |
| Object/Part No./Material | Manufacturer/trademark | Test temperature (°C) | Impression diameter (mm) | |
| Blade holder | | | | |
| SE1X | SABIC INNOVATIVE PLASTICS B V | 125 | 1.6 | |
| SE1 | SABIC INNOVATIVE PLASTICS B V | 125 | 1.6 | |
| SE100 | SABIC INNOVATIVE PLASTICS B V | 125 | 1.5 | |
| C2950 | SABIC INNOVATIVE PLASTICS B V | 125 | 1.4 | |
| CX7211 | SABIC INNOVATIVE PLASTICS B V | 125 | 1.4 | |
| EXCY0098 | SABIC INNOVATIVE PLASTICS B V | 125 | 1.3 | |
| 940 | SABIC INNOVATIVE PLASTICS B V | 125 | 1.6 | |
| LN-1250P | TEIJIN CHEMICALS LTD | 125 | 1.3 | |
| LN-1250G | TEIJIN CHEMICALS LTD | 125 | 1.4 | |
| PA-765A | CHI MEI Corporation | 125 | 1.3 | |
| PC-540 | CHI MEI Corporation | 125 | 1.3 | |
| Bobbin of T1 | | | | |
| T375J | CHANG CHUN PLASTICS CO LTD | 125 | 1.3 | |
| T375HF | CHANG CHUN PLASTICS CO LTD | 125 | 1.3 | |
| PM-9820 | SUMITOMO BAKELITE CO LTD | 125 | 1.3 | |
| CP-J-8800 | HITACHI CHEMICAL CO LTD | 125 | 1.4 | |
| Supplementary information:-- | | | | |

| IEC 62368-1 | | | |
|-------------|--------------------|-----------------|---------|
| Clause | Requirement + Test | Result - Remark | Verdict |

| 5.4.2.2, 5.4.2.4 and 5.4.3 | TABLE: Minimum Clearances/Creepage distance | | | | | | | P |
|---|---|--------------|------------------------------|-----------------------|----------------------|-------------------------------|---------|---|
| Clearance (cl) and creepage distance (cr) at/of/between: | Up (V) | U r.m.s. (V) | Frequency (kHz) ¹ | Required cl (mm) | cl (mm) ² | Required ³ cr (mm) | cr (mm) | |
| For GT-41134-0606-W2-TAB | | | | | | | | |
| Line and Neutral before and after current fuse (F1 or F2) (BI) | 2000 | 120 | <30kHz | 1.88 (1.27 x 1.48) | 3.0 | 1.88 | 3.0 | |
| Two ends of the current fuse (F1 or F2) (BI) | 2000 | 120 | <30kHz | 1.88 (1.27 x 1.48) | 3.0 | 1.88 | 3.0 | |
| Primary and secondary (two sides of CY1 & CY2) (DI) | 2000 | 120 | <30kHz | 3.76 (2.54 x 1.48) | 4.0+4.0 | 3.76 | 4.0+4.0 | |
| Primary to secondary on PCB solder side under T1 (RI) | 2000 | 123 | <30kHz | 3.76 (2.54 x 1.48) | 8.0 | 3.76 | 8.0 | |
| For GT*41134-***-*** | | | | | | | | |
| Line and Neutral before and after current fuse (F1 or F2) (BI) | 2000 | 240 | <30kHz | 1.88 (1.27 x 1.48) | 3.4 | 2.4 | 3.4 | |
| Two ends of the current fuse (F1 or F2) (BI) | 2000 | 240 | <30kHz | 1.88 (1.27 x 1.48) | 3.0 | 2.4 | 3.0 | |
| Live parts to PE bonding terminal (On PCB trace) (for open frame model only) (BI) | 2000 | 240 | <30kHz | 1.88 (1.27 x 1.48) | 3.6 | 2.4 | 3.6 | |
| Primary and secondary (two sides of CY1 & CY2) (DI) | 2000 | 240 | <30kHz | 3.76 (2.54 x 1.48) | 4.0+4.0 | 4.8 | 4.0+4.0 | |
| Primary to secondary on PCB solder side under T1 (RI) | 2000 | 270 | <30kHz | 3.76 (2.54 x 1.48) | 8.0 | 5.4 | 8.0 | |
| Internal live parts to accessible outer enclosure (for adapter model only) (RI) | 2000 | 240 | <30kHz | 3.76 (2.54 x 1.48) | 5.4 | 4.8 | 5.4 | |
| Plug pin-out on the connector side to accessible part when the plug portion is plugged in the socket without the power supply correctly attached.2(for adapter model only) (RI) | 2000 | 240 | <30kHz | 3.76 (2.54 x 1.48) | 5.6 | 4.8 | 5.6 | |
| Line and Neutral before and after current fuse (F1 or F2) (BI) | 2000 | 240 | <30kHz | 1.88 (1.27 x 1.48) | 3.4 | 2.4 | 3.4 | |

| IEC 62368-1 | | | | |
|-------------|--------------------|--|-----------------|---------|
| Clause | Requirement + Test | | Result - Remark | Verdict |

For GT*96060*****

| | | | | | | | |
|--|------|-----|--------|--------------------------|-----|-----|-----|
| L to N before fuse(BI) | 2000 | 240 | <30kHz | 1.88 (1.27 x 1.48) | 3.6 | 2.4 | 3.6 |
| Two poles of fuse(BI) | 2000 | 240 | <30kHz | 1.88 (1.27 x 1.48) | 2.5 | 2.4 | 2.5 |
| Live parts to accessible parts(RI) | 2000 | 240 | <30kHz | 3.76 (2.54 x 1.48) | 7.2 | 4.8 | 7.2 |
| Primary circuits to secondary circuits(RI) | 2000 | 240 | <30kHz | 3.76 (2.54 x 1.48) | 8.0 | 4.8 | 8.0 |
| Primary winding to secondary winding(RI) | 2000 | 204 | <30kHz | 3.76 (2.54 x 1.48) | 8.5 | 4.8 | 8.5 |
| Secondary winding to core(RI) | 2000 | 204 | <30kHz | 3.76 (2.54 x 1.48) | 8.8 | 4.8 | 8.8 |
| Core to secondary parts(RI) | 2000 | 204 | <30kHz | 3.76 (2.54 x 1.48) | 9.6 | 4.8 | 9.6 |

Supplementary information:

Note 1: Only for frequency above 30 kHz

Note 2: See table 5.4.2.4 if this is based on electric strength test

Note 3: Provide Material group IIIb

Note 4: Multiplication factors for Clearances is 1.48

| IEC 62368-1 | | | |
|-------------|--------------------|-----------------|---------|
| Clause | Requirement + Test | Result - Remark | Verdict |

| 5.4.2.3 | TABLE: Minimum Clearances distances using required withstand voltage | | | P |
|---|--|-------------------|------------------|----|
| | Overvoltage Category (OV): | | | II |
| | Pollution Degree: | | | 2 |
| Clearance distanced between: | Required withstand voltage | Required cl (mm) | Measured cl (mm) | |
| For GT-41134-0606-W2-TAB | | | | |
| Line and Neutral before and after current fuse (F1 or F2) (BI) | 2500 | 2.22 (1.5 x 1.48) | 3.0 | |
| Two ends of the current fuse (F1 or F2) (BI) | 2500 | 2.22 (1.5 x 1.48) | 3.0 | |
| Primary and secondary (two sides of CY1 & CY2) (DI) | 2500 | 4.44 (3.0 x 1.48) | 4.0+4.0 | |
| Primary to secondary on PCB solder side under T1 (RI) | 2500 | 4.44 (3.0 x 1.48) | 8.0 | |
| For GT*41134-***-*** | | | | |
| Line and Neutral before and after current fuse (F1 or F2) (BI) | 2500 | 2.22 (1.5 x 1.48) | 3.4 | |
| Two ends of the current fuse (F1 or F2) (BI) | 2500 | 2.22 (1.5 x 1.48) | 3.0 | |
| Live parts to PE bonding terminal (On PCB trace) (for open frame model only) (BI) | 2500 | 2.22 (1.5 x 1.48) | 3.6 | |
| Primary and secondary (two sides of CY1 & CY2) (DI) | 2500 | 4.44 (3.0 x 1.48) | 4.0+4.0 | |
| Primary to secondary on PCB solder side under T1 (RI) | 2500 | 4.44 (3.0 x 1.48) | 8.0 | |
| Internal live parts to accessible outer enclosure (for adapter model only) (RI) | 2500 | 4.44 (3.0 x 1.48) | 5.4 | |
| Plug pin-out on the connector side to accessible part when the plug portion is plugged in the socket without the power supply correctly attached.2(for adapter model only) (RI) | 2500 | 4.44 (3.0 x 1.48) | 5.6 | |
| Line and Neutral before and after current fuse (F1 or F2) (BI) | 2500 | 2.22 (1.5 x 1.48) | 3.4 | |

| IEC 62368-1 | | | |
|-------------|--------------------|-----------------|---------|
| Clause | Requirement + Test | Result - Remark | Verdict |

| | | | |
|---|------|-------------------|-----|
| For GT*96060***** | | | |
| L to N before fuse(BI) | 2500 | 2.22 (1.5 x 1.48) | 3.6 |
| Two poles of fuse(BI) | 2500 | 2.22 (1.5 x 1.48) | 2.5 |
| Live parts to accessible parts(RI) | 2500 | 4.44 (3.0 x 1.48) | 7.2 |
| Primary circuits to secondary circuits(RI) | 2500 | 4.44 (3.0 x 1.48) | 8.0 |
| Primary winding to secondary winding(RI) | 2500 | 4.44 (3.0 x 1.48) | 8.5 |
| Secondary winding to core(RI) | 2500 | 4.44 (3.0 x 1.48) | 8.8 |
| Core to secondary parts(RI) | 2500 | 4.44 (3.0 x 1.48) | 9.6 |
| Supplementary information: Multiplication factors for Clearances is 1.48 | | | |

| 5.4.4.2, 5.4.4.5 c) 5.4.4.9 | TABLE: Distance through insulation measurements | | | | | P |
|---|--|-----------------|--------------|-------------------|-----------------|----------|
| Distance through insulation di at/of: | Peak voltage (V) | Frequency (kHz) | Material | Required DTI (mm) | DTI (mm) | |
| T1 transformer bobbin (RI) | 476 | <100kHz | Phenolic | 0.40 | 0.60 | |
| Insulating tapes in transformer T1 (RI) | 476 | <100kHz | Polyethylene | 0.07 | 3 layers x 0.05 | |
| Supplementary information: Multiplication factors for test voltages is 1.24 | | | | | | |

| IEC 62368-1 | | | |
|-------------|--------------------|-----------------|---------|
| Clause | Requirement + Test | Result - Remark | Verdict |

| 5.4.9 | TABLE: Electric strength tests | | | P |
|---|--------------------------------|--------------------|--------------------|---|
| Test voltage applied between: | Voltage shape (AC, DC) | Test voltage (V) | Breakdown Yes / No | |
| Basic/supplementary: | | | | |
| Fuse two end (When fuse breaks down) | DC | 3224 (2600 x 1.24) | No | |
| Reinforced: | | | | |
| Primary circuit to body | DC | 4960 (4000 x 1.24) | No | |
| Primary circuit to secondary circuit | DC | 4960 (4000 x 1.24) | No | |
| Primary winding to secondary winding of T1 | DC | 4960 (4000 x 1.24) | No | |
| Secondary winding to core | DC | 4960 (4000 x 1.24) | No | |
| Insulation tape around transformer per layer | DC | 4960 (4000 x 1.24) | No | |
| Primary and secondary of Y1 capacitor | DC | 4960 (4000 x 1.24) | No | |
| Supplementary information: Multiplication factors for test voltages is 1.24 | | | | |

| IEC 62368-1 | | | |
|-------------|--------------------|-----------------|---------|
| Clause | Requirement + Test | Result - Remark | Verdict |

| 6.2.2 | | Table: Electrical power sources (PS) measurements for classification | | | P |
|--------|------------------------------------|--|---------------------|-----------------------------------|-------------------|
| Source | Description | Measurement | Max Power after 3 s | Max Power after 5 s ^{*)} | PS Classification |
| A | Model GTM41134-0603-*** output | Power (W) : | 7.71 | -- | PS1 |
| | | V _A (V) : | 3.30 | -- | |
| | | I _A (A) : | 2.55 | -- | |
| B | Model GTM41134-0606-1.0-*** output | Power (W) : | 7.58 | -- | PS1 |
| | | V _A (V) : | 5.01 | -- | |
| | | I _A (A) : | 1.51 | -- | |
| C | Model GT-41134-0606-W2-TAB output | Power (W) : | 7.62 | -- | PS1 |
| | | V _A (V) : | 6.10 | -- | |
| | | I _A (A) : | 1.27 | -- | |
| D | Model GTM41134-0612-3.0-*** output | Power (W) : | 7.66 | -- | PS1 |
| | | V _A (V) : | 8.99 | -- | |
| | | I _A (A) : | 0.85 | -- | |
| E | Model GTM41134-0648-*** output | Power (W) : | 7.68 | -- | PS1 |
| | | V _A (V) : | 47.97 | -- | |
| | | I _A (A) : | 0.16 | -- | |

Supplementary Information:

(*) Measurement taken only when limits at 3 seconds exceed PS1 limits

| IEC 62368-1 | | | |
|-------------|--------------------|-----------------|---------|
| Clause | Requirement + Test | Result - Remark | Verdict |

| B.2.5 | TABLE: Input test | | | | | | | P |
|-----------------------------|-------------------|-------------|-------|-------------|---------|------------|--|---|
| U (V) | I (A) | I rated (A) | P (W) | P rated (W) | Fuse No | I fuse (A) | Condition/status | |
| Model GTM41134-0603-*** | | | | | | | | |
| 90Vac | 0.174 | 0.6 | 10.2 | -- | F1, F2 | 0.174 | Normal operation with 3.3Vdc / 1.8A output. | |
| 100Vac | 0.161 | 0.6 | 10.0 | -- | F1, F2 | 0.161 | | |
| 240Vac | 0.089 | 0.6 | 10.1 | -- | F1, F2 | 0.089 | | |
| 264Vac | 0.084 | 0.3 | 10.1 | -- | F1, F2 | 0.084 | | |
| Model GTM41134-0606-1.0-*** | | | | | | | | |
| 90Vac | 0.154 | 0.6 | 8.70 | -- | F1, F2 | 0.154 | Normal operation with 5Vdc / 1.2A output. | |
| 100Vac | 0.141 | 0.6 | 8.50 | -- | F1, F2 | 0.141 | | |
| 240Vac | 0.077 | 0.6 | 8.40 | -- | F1, F2 | 0.077 | | |
| 264Vac | 0.072 | 0.6 | 8.40 | -- | F1, F2 | 0.072 | | |
| Model GTM41134-0612-3.0-*** | | | | | | | | |
| 90Vac | 0.155 | 0.6 | 9.30 | -- | F1, F2 | 0.155 | Normal operation with 9Vdc / 0.66A output. | |
| 100Vac | 0.143 | 0.6 | 9.30 | -- | F1, F2 | 0.143 | | |
| 240Vac | 0.083 | 0.6 | 8.70 | -- | F1, F2 | 0.083 | | |
| 264Vac | 0.076 | 0.6 | 8.50 | -- | F1, F2 | 0.076 | | |
| Model GTM41134-0648-*** | | | | | | | | |
| 90Vac | 0.149 | 0.6 | 8.90 | -- | F1, F2 | 0.149 | Normal operation with 48Vdc / 0.125A output. | |
| 100Vac | 0.137 | 0.6 | 8.70 | -- | F1, F2 | 0.137 | | |
| 240Vac | 0.080 | 0.6 | 7.90 | -- | F1, F2 | 0.080 | | |
| 264Vac | 0.076 | 0.6 | 8.10 | -- | F1, F2 | 0.076 | | |
| Model GT-41134-0606-W2-TAB | | | | | | | | |
| 108Vac | 0.124 | 0.6 | 8.90 | -- | F1 | 0.124 | Normal operation with 6Vdc / 1.0A output. | |
| 120Vac | 0.136 | 0.6 | 9.30 | -- | F1 | 0.136 | | |
| 132Vac | 0.145 | 0.6 | 9.20 | -- | F1 | 0.145 | | |
| Model GTM96060-0603 | | | | | | | | |
| 90Vac | 0.174 | 0.6 / 0.3 | 10.2 | -- | F1 | 0.174 | Normal operation with 3.3Vdc / 1.8A output. | |
| 100Vac | 0.161 | 0.6 / 0.3 | 10.0 | -- | F1 | 0.161 | | |
| 240Vac | 0.089 | 0.6 / 0.3 | 10.1 | -- | F1 | 0.089 | | |
| 264Vac | 0.084 | 0.6 / 0.3 | 10.1 | -- | F1 | 0.084 | | |
| Model GTM96060-0606-1.0 | | | | | | | | |

| IEC 62368-1 | | | |
|-------------|--------------------|-----------------|---------|
| Clause | Requirement + Test | Result - Remark | Verdict |

| B.2.5 | TABLE: Input test | | | | | | P |
|---|-------------------|-------------|-------|-------------|---------|------------|--|
| U (V) | I (A) | I rated (A) | P (W) | P rated (W) | Fuse No | I fuse (A) | Condition/status |
| 90Vac | 0.153 | 0.6 / 0.3 | 7.982 | -- | F1 | 0.153 | Normal operation with 5.0Vdc / 1.2A output. |
| 100Vac | 0.139 | 0.6 / 0.3 | 7.873 | -- | F1 | 0.139 | |
| 240Vac | 0.081 | 0.6 / 0.3 | 7.988 | -- | F1 | 0.081 | |
| 264Vac | 0.076 | 0.6 / 0.3 | 8.096 | -- | F1 | 0.076 | |
| Model GTM96060-0648 | | | | | | | |
| 90Vac | 0.149 | 0.6 / 0.3 | 8.90 | -- | F1 | 0.149 | Normal operation with 48Vdc / 0.125A output. |
| 100Vac | 0.137 | 0.6 / 0.3 | 8.70 | -- | F1 | 0.137 | |
| 240Vac | 0.080 | 0.6 / 0.3 | 7.90 | -- | F1 | 0.080 | |
| 264Vac | 0.076 | 0.6 / 0.3 | 8.10 | -- | F1 | 0.076 | |
| Supplementary information: Equipment may be have rated current or rated power or both. Both should be measured | | | | | | | |

| B.3 | TABLE: Abnormal operating condition tests | | | | | | | P |
|---|---|---------------------|------------------|----------|-------------------|------------------|------------|-------------|
| Ambient temperature (°C) | | | | | 25 | | — | |
| Power source for EUT: Manufacturer, model/type, output rating .. : | | | | | See below | | — | |
| Component No. | Abnormal Condition | Supply voltage, (V) | Test time (hour) | Fuse no. | Fuse current, (A) | T-couple | Temp. (°C) | Observation |
| Model GT-41134-0648 output | O/L | 264 | 4 | F1, F2 | 0.059→0.077 | T1 winding | 107.0 | No hazards |
| Model GT-41134-0606-W2-TAB output | O/L | 132 | 4 | F1 | 0.145→0.152 | T1 winding | 108.1 | No hazards |
| Model GTM96060-0606-1.0 output | O/L | 264 | 1 | F1 | 0.088 | T1 winding | 75.0 | No hazards |
| Model GTM96060-0648 output | O/L | 264 | 4 | F1 | 0.106 | T1 c winding oil | 109.0 | No hazards |
| Model GTM96060-0603 output | O/L | 264 | 4 | F1 | 0.095 | T1 winding | 85.0 | No hazards |
| Supplementary information: Test table is provided to record abnormal and fault conditions for all applicable energy sources including Thermal burn injury. Column "Abnormal/Fault." Specify if test condition by indicating "Abnormal" then the condition for a Clause B.3 test or "Single Fault" then the condition for Clause B.4. | | | | | | | | |

| IEC 62368-1 | | | |
|-------------|--------------------|-----------------|---------|
| Clause | Requirement + Test | Result - Remark | Verdict |

| B.4 | | TABLE: Fault condition tests | | | | | | | P |
|--|-----------------|------------------------------|-----------------|----------|-------------------|----------|------------|-------------------------------|---|
| Ambient temperature (°C) | | | | | 25 | | — | | |
| Power source for EUT: Manufacturer, model/type, output rating .. | | | | | See below | | — | | |
| Component No. | Fault Condition | Supply voltage, (V) | Test time (min) | Fuse no. | Fuse current, (A) | T-couple | Temp. (°C) | Observation | |
| Model GT-41134-0648 is chosen as the evaluation model. | | | | | | | | | |
| C1 | SC | 264 | 30 | F1, F2 | 0.059→>2.1 | -- | -- | Fuse (F1) opened. No hazards. | |
| D1 | SC | 264 | 30 | F1, F2 | 0.059→>2.1 | -- | -- | Fuse (F1) opened. No hazards. | |
| D5 | SC | 264 | 30 | F1, F2 | 0.059→0.003 | -- | -- | Unit shut down. No hazards. | |
| C3 | SC | 264 | 30 | F1, F2 | 0.059→0.003 | -- | -- | Unit shut down. No hazards. | |
| U1 pin 1 to pin 2 | SC | 264 | 30 | F1, F2 | 0.059→0.012 | -- | -- | Unit shut down. No hazards. | |
| U1 pin 2 to pin 3 | SC | 264 | 30 | F1, F2 | 0.059→0.013 | -- | -- | Unit shut down. No hazards. | |
| U1 pin4 to pin 5 | SC | 264 | 30 | F1, F2 | 0.059→0.011 | -- | -- | Unit shut down. No hazards. | |
| U1 pin 5 to pin 6 | SC | 264 | 30 | F1, F2 | 0.059→0.012 | -- | -- | Unit shut down. No hazards. | |
| CS4 | SC | 264 | 30 | F1, F2 | 0.059→0.023 | -- | -- | Unit shut down. No hazards. | |
| RS12 | SC | 264 | 30 | F1, F2 | 0.059→0.014 | -- | -- | Unit shut down. No hazards. | |
| CS2 | SC | 264 | 30 | F1, F2 | 0.059→0.026 | -- | -- | Unit shut down. No hazards. | |
| CS4 | SC | 264 | 30 | F1, F2 | 0.059→0.007 | -- | -- | Unit shut down. No hazards. | |
| Q1 pin C to pin E | SC | 264 | 30 | F1, F2 | 0.059A→0.009 | -- | -- | Unit shut down. No hazards. | |

| IEC 62368-1 | | | | | | | | |
|----------------------------|--------------------|-----|----|--------|-----------------|----|----|-------------------------------|
| Clause | Requirement + Test | | | | Result - Remark | | | Verdict |
| Q1 pin B to pin E | SC | 264 | 30 | F1, F2 | 0.059→>2.1 | -- | -- | Fuse (F1) opened. No hazards. |
| Q1 pin C to pin E | SC | 264 | 30 | F1, F2 | 0.059→>2.1 | -- | -- | Fuse (F1) opened. No hazards. |
| T1 pin 10 to pin 8 | SC | 264 | 30 | F1, F2 | 0.059→0.015 | -- | -- | Unit shut down. No hazards. |
| Output | SC | 264 | 30 | F1, F2 | 0.059→0.009 | -- | -- | Unit shut down. No hazards. |
| Model GT-41134-0606-W2-TAB | | | | | | | | |
| C1 | SC | 132 | 30 | F1 | 0.145→>13.3 | -- | -- | Fuse (F1) opened. No hazards. |
| MOV1 | SC | 132 | 30 | F1 | 0.145→>13.3 | -- | -- | Fuse (F1) opened. No hazards. |
| Output | SC | 132 | 30 | F1 | 0.145→0.002 | -- | -- | Unit shut down. No hazards. |
| Model GTM96060-0603 | | | | | | | | |
| Output | SC | 264 | 10 | F1 | 0.084→0.003 | -- | -- | Unit shut down. No hazards. |
| C5 | SC | 264 | 10 | F1 | 0.084→0.003 | -- | -- | Unit shut down. No hazards. |
| Q1 pinD-S | SC | 264 | 10 | F1 | 0.084→>2.1 | -- | -- | Fuse (F1) opened. No hazards. |
| Q1 pinG-S | SC | 264 | 10 | F1 | 0.084→0.003 | -- | -- | Unit shut down. No hazards. |
| T1 pin10-pin8 | SC | 264 | 10 | F1 | 0.084→0.003 | -- | -- | Unit shut down. No hazards. |
| C1 | SC | 264 | 10 | F1 | 0.084→>2.1 | -- | -- | Fuse (F1) opened. No hazards. |
| D1 | SC | 264 | 10 | F1 | 0.084→>2.1 | -- | -- | Fuse (F1) opened. No hazards. |
| Model GTM96060-0606-1.0 | | | | | | | | |

| IEC 62368-1 | | | | | | | | |
|---|--------------------|-----|----|----|-----------------|----|----|-------------------------------|
| Clause | Requirement + Test | | | | Result - Remark | | | Verdict |
| Output | SC | 264 | 10 | F1 | 0.076→ 0.003 | -- | -- | Unit shut down. No hazards. |
| C5 | SC | 264 | 10 | F1 | 0.076→ 0.003 | -- | -- | Unit shut down. No hazards. |
| Q1 pinD-S | SC | 264 | 10 | F1 | 0.076→ >2.1 | -- | -- | Fuse (F1) opened. No hazards. |
| Q1 pinG-S | SC | 264 | 10 | F1 | 0.076→ 0.003 | -- | -- | Unit shut down. No hazards. |
| T1 pin10-pin8 | SC | 264 | 10 | F1 | 0.076→ 0.003 | -- | -- | Unit shut down. No hazards. |
| C1 | SC | 264 | 10 | F1 | 0.076→ >2.1 | -- | -- | Fuse (F1) opened. No hazards. |
| D1 | SC | 264 | 10 | F1 | 0.076→ >2.1 | -- | -- | Fuse (F1) opened. No hazards. |
| Model GTM96060-0648 | | | | | | | | |
| Output | SC | 264 | 10 | F1 | 0.076→ 0.003 | -- | -- | Unit shut down. No hazards. |
| C5 | SC | 264 | 10 | F1 | 0.076→ 0.003 | -- | -- | Unit shut down. No hazards. |
| Q1 pinD-S | SC | 264 | 10 | F1 | 0.076→ >2.1 | -- | -- | Fuse (F1) opened. No hazards. |
| Q1 pinG-S | SC | 264 | 10 | F1 | 0.076→ 0.003 | -- | -- | Unit shut down. No hazards. |
| T1 pin10-pin8 | SC | 264 | 10 | F1 | 0.076→ 0.003 | -- | -- | Unit shut down. No hazards. |
| C1 | SC | 264 | 10 | F1 | 0.076→ >2.1 | -- | -- | Fuse (F1) opened. No hazards. |
| D1 | SC | 264 | 10 | F1 | 0.076→ >2.1 | -- | -- | Fuse (F1) opened. No hazards. |
| Supplementary information: - short circuit SC; - open circuit OC; - overload O/L | | | | | | | | |

| IEC 62368-1 | | | |
|-------------|--------------------|-----------------|---------|
| Clause | Requirement + Test | Result - Remark | Verdict |

| T.2, T.3, T.4, T.5 | TABLE: Steady force test | | | | | P |
|------------------------------|--------------------------|----------------|-----------|---------------------|-------------|---|
| Part/Location | Material | Thickness (mm) | Force (N) | Test Duration (sec) | Observation | |
| Internal wire | PVC | -- | 10 | 5 | No hazards | |
| Enclosure | Plastic | Min. 1.5 | 30 | 5 | No hazards | |
| Enclosure | Plastic | Min. 1.5 | 100 | 5 | No hazards | |
| Supplementary information:-- | | | | | | |

| T.7 | TABLE: Drop tests | | | | P |
|------------------------------|-------------------|----------------|------------------|-------------|---|
| Part/Location | Material | Thickness (mm) | Drop Height (mm) | Observation | |
| Whole product | Plastic enclosure | Min. 1.5 | 1000 | No hazards | |
| Supplementary information:-- | | | | | |

| T.8 | TABLE: Stress relief test | | | | | P |
|------------------------------|---------------------------|----------------|-----------------------|--------------|-------------|---|
| Part/Location | Material | Thickness (mm) | Oven Temperature (°C) | Duration (h) | Observation | |
| Whole product | Plastic enclosure | Min. 1.5 | 89.2 | 7 | No hazards | |
| Supplementary information:-- | | | | | | |

Photographs:

PHOTO 1: EXTERNAL VIEW – 1 OF ADAPTER MODEL GT*41134-***

PHOTO 2: EXTERNAL VIEW – 2 OF ADAPTER MODEL GT*41134-***

PHOTO 3: EXTERNAL VIEW – 3 OF ADAPTER MODEL GT*41134-***

PHOTO 4: INTERNAL VIEW OF ADAPTER MODEL GT*41134-***

PHOTO 5: COMPONENT SIDE VIEW OF PCB OF ADAPTER MODEL GT*41134-***

PHOTO 6: SOLDERING SIDE VIEW OF PCB OF ADAPTER MODEL GT*41134-***

PHOTO 7: COMPONENT SIDE VIEW OF OPEN FRAME MODEL

PHOTO 8: SOLDERING SIDE VIEW OF OPEN FRAME MODEL

PHOTO 9: COMPONENT SIDE OF OPEN FRAME MODEL WITH APPLIANCE INLET

PHOTO 10: SOLDERING SIDE OF OPEN FRAME MODEL WITH APPLIANCE INLET

PHOTO 11: EXTERNAL VIEW - 1 OF MODEL GT-41134-0606-W2-TAB

PHOTO 12: EXTERNAL VIEW – 2 OF MODEL GT-41134-0606-W2-TAB

Photo 13: Component side view of PCB of model GT-41134-0606-W2-TAB

Photo 14: Soldering side view of PCB of model GT-41134-0606-W2-TAB

PHOTO 15: Overall view for the structure type only use F1 and a LED indicator (optional)



PHOTO 16: Overall view for the structure type only use F1 and a LED indicator (optional)

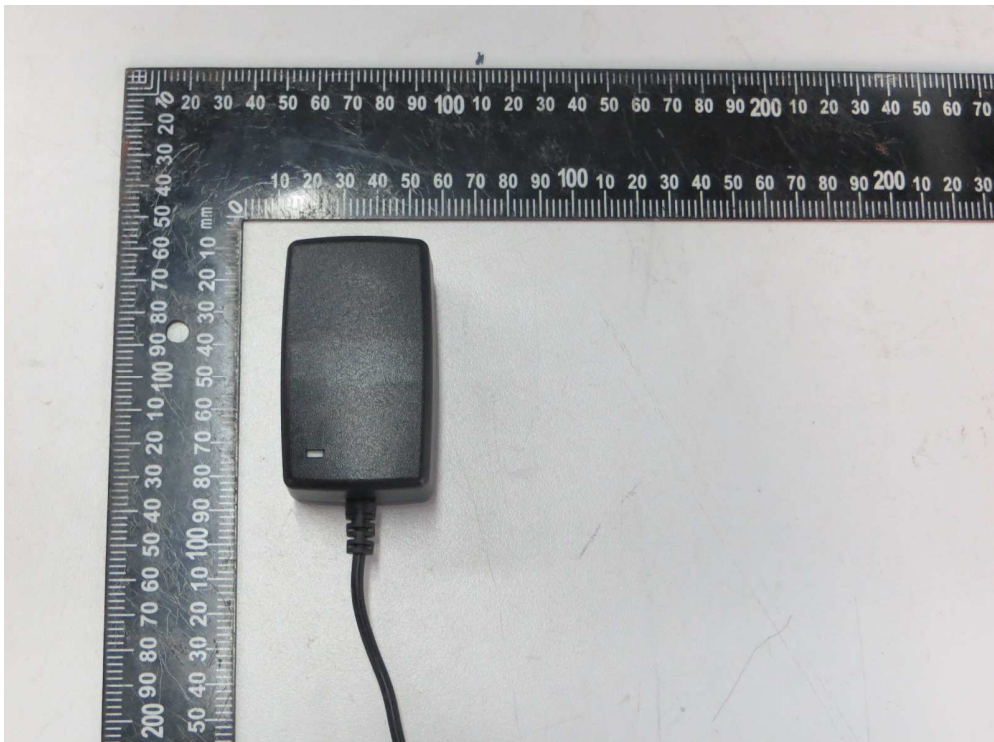

PHOTO 17: Internal view for the structure type only use F1 and a LED indicator (optional)

PHOTO 18: Internal view for the structure type only use F1 and a LED indicator (optional)

PHOTO 19: PCB view for the structure type only use F1 and a LED indicator (optional)

PHOTO 20: PCB view for the structure type only use F1 and a LED indicator (optional)

| | |
|---|---------------------|
| ATTACHMENT TO TEST REPORT IEC 62368-1 2th Ed. U.S.A. NATIONAL DIFFERENCES Audio/video, information and communication technology equipment – Part 1: Safety requirements | |
| Differences according to: | CSA/UL 62368-1:2014 |
| Attachment Form No.: | US&CA_ND_IEC623681B |
| Attachment Originator | UL(US) |
| Master Attachment: | Date 2015-06 |
| Copyright © 2015 IEC System for Conformity Testing and Certification of Electrical Equipment (IECEE), Geneva, Switzerland. All rights reserved. | |

| Clause | Requirement + Test | Result - Remark | Verdict |
|--------|--------------------|-----------------|---------|
|--------|--------------------|-----------------|---------|

| IEC 62368-1 - US and Canadian National Differences Special National Conditions based on Regulations and Other National Differences | | | |
|---|---|--|-----|
| 1.1 | All equipment is to be designed to allow installation according to the National Electrical Code (NEC), ANSI/NFPA 70, the Canadian Electrical Code (CEC), Part I, CAN/CSA C22.1, and when applicable, the National Electrical Safety Code, IEEE C2. Also, for such equipment marked or otherwise identified, installation is allowed per the Standard for the Protection of Information Technology Equipment, ANSI/NFPA 75. | | — |
| 1.4 | Additional requirements apply to some forms of power distribution equipment, including sub-assemblies. | | — |
| 4.1.17 | For lengths exceeding 3.05 m, external interconnecting flexible cord and cable assemblies are required to be a suitable cable type (e.g., DP, CL2) specified in the NEC. | | N/A |
| | For lengths 3.05 m or less, external interconnecting flexible cord and cable assemblies that are not types specified in the NEC generally are required to have special construction features and identification markings. | | N/A |
| 4.8 | Lithium coin / button cell batteries have modified special construction and performance requirements. | | N/A |
| 5.6.3 | Protective earthing conductors comply with the minimum conductor sizes in Table G.5, except as required by Table G.7ADV.1 for cord connected equipment, or Annex DVH for permanently connected equipment | | N/A |

| Clause | Requirement + Test | Result - Remark | Verdict |
|-------------------|---|-----------------|---------|
| 5.7.7 | Equipment intended to receive telecommunication ringing signals complies with a special touch current measurement tests. | | N/A |
| 6.5.1 | PS3 wiring outside a fire enclosure complies with single fault testing in B.4, or be current limited per one of the permitted methods. | | N/A |
| Annex F (F.3.3.8) | Output terminals provided for supply of other equipment, except mains, supply are marked with a maximum rating or references to which equipment it is permitted to be connected. | | P |
| Annex G (G.7.1) | Permanent connection of equipment to the mains supply by a power supply cord is not permitted, except for certain equipment, such as ATMs. | | N/A |
| Annex G (G.7.3) | Power supply cords are required to have attachment plugs rated not less than 125 percent of the rated current of the equipment. | | N/A |
| | Flexible power supply cords are required to be compatible with Article 400 of the NEC, and Tables 11 and 12 of the CEC. | | N/A |
| Annex G (G.7.5) | Minimum cord length is required to be 1.5 m, with certain constructions such as external power supplies allowed to consider both input and output cord lengths into the requirement. Power supply cords are required to be no longer than 4.5 m in length if used in ITE Rooms. | | N/A |
| Annex H.2 | Continuous ringing signals under normal operating conditions up to 16 mA only are permitted if the equipment is subjected to special installation and performance restrictions. | | N/A |
| Annex H.4 | For circuits with other than ringing signals and with voltages exceeding 42.4 V _{peak} or 60 V d.c., the maximum acceptable current through a 2000 ohm resistor (or greater) connected across the voltage source with other loads disconnected is 7.1 mA peak or 30 mA d.c. under normal operating conditions. | | N/A |
| Annex M | Battery packs for stationary applications comply with special component requirements. | | N/A |

| Clause | Requirement + Test | Result - Remark | Verdict |
|--------------------|--|-----------------|---------|
| Annex DVA (1) | Equipment intended for use in spaces used for environmental air are subjected to special flammability requirements for heat and visible smoke release. | | N/A |
| | For ITE room applications, automated information storage systems with combustible media greater than 0.76 m ³ (27 cu ft) have a provision for connection of either automatic sprinklers or a gaseous agent extinguishing system with an extended discharge. | | N/A |
| | Consumer products designed or intended primarily for children 12 years of age or younger are subject to additional requirements in accordance with U.S. & Canadian Regulations. | | N/A |
| | Baby monitors additionally comply with ASTM F2951, Consumer Safety Specification for Baby Monitors. | | N/A |
| Annex DVA (5.6.3) | For Pluggable Equipment Type A, the protection in the installation is assumed to be 20A. | | P |
| Annex DVA (6.3) | The maximum quantity of flammable liquid stored in equipment complies with NFPA 30. | | N/A |
| Annex DVA (6.4.8) | For ITE room applications, enclosures with combustible material measuring greater than 0.9 m ² (10 sq ft) or a single dimension greater than 1.8 m (6 ft) have a flame spread rating of 50 or less. For equipment with the same dimensions for other applications, an external surface that is not a fire enclosure requires a min. flammability classification of V-1. | | N/A |
| Annex DVA (10.3.1) | Equipment with lasers meets the U.S. Code of Federal Regulations 21 CFR 1040 (and the Canadian Radiation Emitting Devices Act, REDR C1370). | | N/A |
| Annex DVA (10.5.1) | Equipment that produces ionizing radiation complies with the U.S. Code of Federal Regulations, 21 CFR 1020 (and the Canadian Radiation Emitting Devices Act, REDR C1370). | | N/A |

| Clause | Requirement + Test | Result - Remark | Verdict |
|---------------------|--|-----------------|---------|
| Annex DVA (F.3.3.3) | Equipment for use on a.c. mains supply systems with a neutral and more than one phase conductor (e.g. 120/240 V, 3-wire) require a special marking format for electrical ratings. Additional considerations apply for voltage ratings that exceed the attachment cap rating or are lower than the "Normal Operating Condition" in Table 2 of CAN/CSA C22.2 No. 235." | | N/A |
| Annex DVA (F.3.3.5) | Equipment identified for ITE (computer) room installation is marked with the rated current | | N/A |
| Annex DVA (G.1) | Vertically-mounted disconnect switches and circuit breakers have the "on" position indicated by the handle in the up position | | N/A |
| Annex DVA (G.3.4) | Suitable NEC/CEC branch circuit protection rated at the maximum circuit rating is required for all standard supply outlets and receptacles (such as supplied in power distribution units) if the supply branch circuit protection is not suitable. | | N/A |
| Annex DVA (G.4.2) | Equipment with isolated ground (earthing) receptacles complies with NEC 250.146(D) and CEC 10-112 and 10-906(8). | | N/A |
| Annex DVA (G.4.3) | Where a fuse is used to provide Class 2 or Class 3 current limiting, it is not operator-accessible unless it is non- interchangeable. | | N/A |
| Annex DVA (G.5.3) | Power distribution transformers distributing power at 100 volts or more, and rated 10 kVA or more, require special transformer overcurrent protection. | | N/A |
| Annex DVA (G.5.4) | Motor control devices are required for cord-connected equipment with a mains-connected motor if the equipment is rated more than 12 A, or if the equipment has a nominal voltage rating greater than 120 V, or if the motor is rated more than 1/3 hp (locked rotor current over 43 A). | | N/A |
| Annex DVA (Annex M) | For ITE room applications, equipment with battery systems capable of supplying 750 VA for five minutes have a battery disconnect means that may be connected to the ITE room remote power-off circuit. | | N/A |

| Clause | Requirement + Test | Result - Remark | Verdict |
|---------------------|--|-----------------|---------|
| Annex DVA (Q) | Wiring terminals intended to supply Class 2 outputs according to the NEC or CEC Part 1 are marked with the voltage rating and “Class 2” or equivalent; marking is located adjacent to the terminals and visible during wiring. | | N/A |
| Annex DVB (1) | Additional requirements apply for equipment used for entertainment purposes intended for installation in general patient care areas of health care facilities. | | N/A |
| Annex DVC (1) | Additional requirements apply for equipment intended for mounting under kitchen cabinets. | | N/A |
| Annex DVE (4.1.1) | Some equipment, components, sub-assemblies and materials associated with the risk of fire, electric shock, or personal injury have component or material ratings in accordance with the applicable national (U.S. and Canadian) component or material requirements. Components required to comply include: appliance couplers, attachment plugs, battery back-up systems, battery packs, circuit breakers, communication circuit accessories, connectors (used for current interruption of non-LPS circuits), power supply cords, direct plug-in equipment, electrochemical capacitor modules (energy storage modules with ultra-capacitors), enclosures (outdoor), flexible cords and cables, fuses (branch circuit), ground-fault current interrupters, interconnecting cables, data storage equipment, printed wiring, protectors for communications circuits, receptacles, surge protective devices, vehicle battery adapters, wire connectors, and wire and cables. | | N/A |
| Annex DVH | Equipment for permanent connection to the mains supply is subjected to additional requirements. | | N/A |
| Annex DVH (DVH.1) | Wiring methods (terminals, leads, etc.) used for the connection of the equipment to the mains are in accordance with the NEC/CEC. | | N/A |
| Annex DVH (DVH.3.2) | Terminals for permanent wiring, including protective earthing terminals, are suitable for U.S./Canadian wire gauge sizes, rated 125 percent of the equipment rating, and are specially marked when specified. | | N/A |

| Clause | Requirement + Test | Result - Remark | Verdict |
|---------------------|--|-----------------|---------|
| Annex DVH (DVH.3.2) | Wire binding screws are not permitted to attach conductors larger than 10 AWG (5.3 mm ²). | | N/A |
| Annex DVH (DVH.4) | Permanently connected equipment is required to have a suitable wiring compartment and wire bending space. | | N/A |
| Annex DVH (DVH 5.5) | Equipment connected to a centralized d.c. power system, and having one pole of the DC mains input terminal connected to the main protective earthing terminal in the equipment, complies with special earthing, wiring, marking and installation instruction requirements. | | N/A |
| Annex DVI (6.7) | Equipment intended for connection to telecommunication network outside plant cable is required to be protected against overvoltage from power line crosses. | | N/A |
| Annex DVJ (10.6.1) | Equipment connected to a telecommunication and cable distribution networks and supplied with an earphone intended to be held against, or in the ear is required to comply with special acoustic pressure requirements. | | N/A |

| Clause | Requirement + Test | Result - Remark | Verdict |
|--------|--------------------|-----------------|---------|
|--------|--------------------|-----------------|---------|

Appendix: Equipment combined with two-pole plug (Class II)

Supplementary tests on plug portion according to EN 50075:1990

1. Dimensions (Clause 7 of EN 50075)

Plugs shall comply with standard size. (Standard sheet 1) P

2. Protection Against Electric Shock (Clause 8 of EN 50075)

2.1 Live parts of plugs with the exception of the bare metal parts of the pins, shall not be accessible. (Clause 8.1 of EN 50075) P

2.2 It shall not be possible to make connection between a pin of a plug and a live socket contact of a socket-outlet while the other pin is an accessible. (Clause 8.2 of EN 50075) P

2.3 External parts of plugs, with the exception of pins, shall be of insulating material. (Clause 8.3 of EN 50075) P

3. Construction (Clause 9 of EN 50075)

3.1 The plug cannot be opened by hand or by using a general purpose tool. (Clause 9.1 of EN 50075) P

3.2 Pins of plugs shall be solid and shall have adequate mechanical strength. (Clause 9.3 of EN 50075) P

3.3 Pins of plugs shall be locked against rotation and adequately fixed into the body of the plug. (Clause 9.4 of EN 50075) P

3.4 Plugs shall be provided with soldered, crimped or equally effective permanent connection. (Clause 9.5 of EN 50075) P

3.5 Plug shall be shaped in such a way and made of such a material that they can easily be withdrawn by hand from a socket-outlet. (by gripping the medical power supply's enclosure, Clause 9.6 of EN 50075) P

4. Resistance to Humidity (Clause 10 of EN 50075) N/A

The integrated pins were tested together with the medical power supply. (See test report for medical power supply)

| Clause | Requirement + Test | Result - Remark | Verdict |
|--------|---|-----------------|---------|
| 5. | Insulation Resistance and Electric Strength (Clause 11 of EN 50075) | | N/A |
| | (See test report for medical power supply) | | |
| 6. | Mechanical Strength (Clause 13 of EN 50075) | | |
| | Plug shall have adequate mechanical strength to withstand the stresses imposed during use. | | P |
| 6.1 | The plugs are pressed between two flat surfaces with a force of 150N for 5min. 15min after removal of the force, the plug shall not show such deformation as would result in undue alteration of the dimensions which ensure safety. (Clause 13.1 of EN 50075) | | P |
| 6.2 | The plug is tested in a tumbling barrel. (Clause 13.2 of EN 50075, fall number is shown in test report for medical power supply) After the test, the plug shall show no damage within the meaning of this standard, in particular: --- No part shall become detached or loosened. --- The pin shall not turn when a torque of 0.4Nm is applied. Note: A section of the pin is square constructed for preventing the rotation. | | P |
| 6.3 | The pins is held in a suitable clamp in such a position that the straight part of a steel wire (D=1+-0.02mm, U-shaped) rests on the plug pin. The plug is caused to move backwards and forwards, so that the wire rubs along the pin. The number of the movements is 20 000, and the rate of the operation is 25 movements per min. (Clause 13.3 of EN 50075) | | P |
| | After the test, the pin show no damage which may effect safety or impair the further use of the plug, in particular, the insulating sleeve shall not have punctured or rucked up. | | P |
| 6.4 | A pull force of 40N is applied for 60s on each pin in turn in the direction of the longitudinal axis of the pin. The pull is applied 60min after the plug has been placed in a heating cabinet of 70°C. After the plug cooling down to ambient temperature, any pin shall not have displaced in the body of the plug more than 1mm. (Clause 13.4 of EN 50075) | | P |
| 7. | Resistance to Heat and to Ageing (Clause 14 of EN 50075) | | P |

| Clause | Requirement + Test | Result - Remark | Verdict |
|------------|---|-----------------|---------|
| 8. | Current-carrying Parts and Connections (Clause 15 of EN 50075) | | |
| 8.1 | Connection, electrical and mechanical, shall withstand the mechanical stresses occurring in normal use, and electrical connections shall be designed that contact pressure is not transmitted through insulating material. (Clause 15.1 & 15.2 of EN 50075) | | P |
| 8.2 | Current-carrying parts shall be of copper or an alloy containing at least 58% of copper. (Clause 15.3 of EN 50075) | | P |
| 9. | Creepage Distance, Clearances, and Distances Through Insulation (Clause 16 of EN 50075) | | P |
| 10. | Resistance of Insulating Material to Abnormal Heat and to fire (Clause 17 of EN 50075) | | P |

Appendix: Dimensions of integral plug

| Clause | Requirement + Test | Result - Remark | Verdict |
|----------|--|-----------------|---------|
| | DIMENSIONS Checked by means of measurement according to EN50075 Standard sheet 1 | | P |
| Position | Requirement (mm) | Measured (mm) | Verdict |
| 1 | 25,6 – 26,6 | 25,84 | P |
| 2 | 13 – 14,4 | 13,98 | P |
| 3 | 45° | 45° | P |
| 4 | R5 – 6 | R5,4 | P |
| 5 | 34,6 – 36 | 35,09 | P |
| 6 | 18-19,2 in the plane of the engagement face | 18,15 | P |
| | 17-18 at the ends of the pins | 17,55 | P |
| 7 | 4min | - | N/A |
| 8 | φ3,8max | φ3,42 | P |
| 9 | 10-11 | 10,05 | P |
| 10 | 18,5 – 19,5 | 19,12 | P |
| 11 | φ3,94 - φ4,06 | φ3,98 | P |
| | Dimensions of position 1, 2 and 3 shall not be exceeded within a distance of 18mm from the engagement face of the plug | 19,15 | P |
| | The edges of the metal parts shall be either chamfered or rounded off | Rounded off | P |

EN50075: 1990 STANDARD SHEET 1

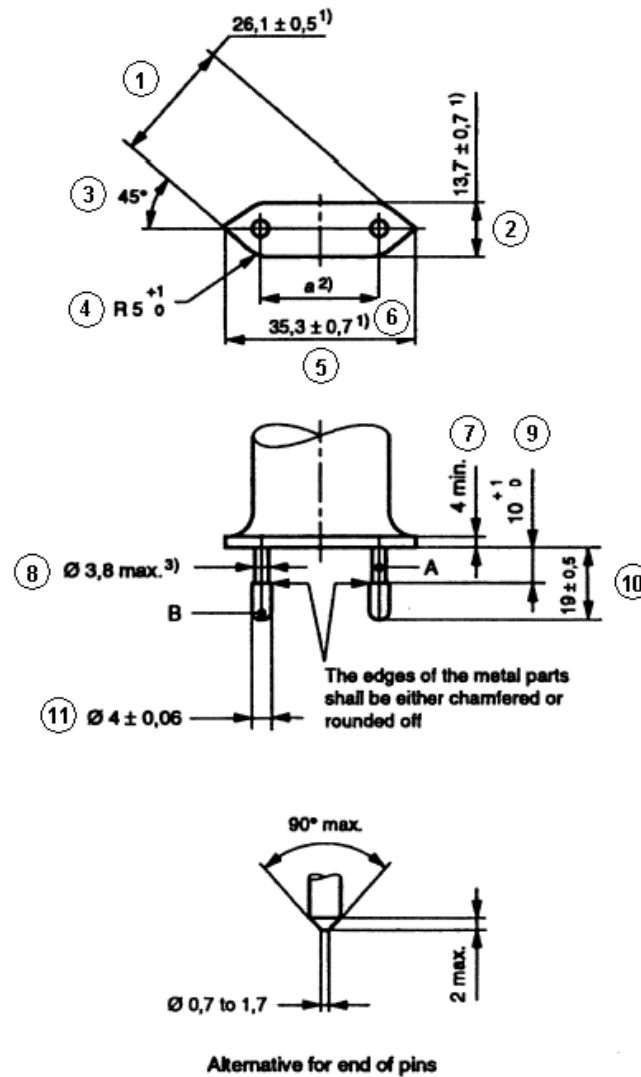

Dimensions in millimetres

1) These dimensions shall not be exceeded within a distance of 18 mm from the engagement face of the plug.

2) Dimension *a* is:

18 mm to 19,2 mm in the plane of the engagement face;

17 mm to 18 mm at the ends of the pins.

3) This dimension may be increased to 4 mm within a distance of 4 mm from the engagement face of the plug.

Pin ends shall be rounded, or conical as shown in detail sketch.

The sketches are not intended to govern design except as regards the dimensions shown.

Appendix: Photo for plug portion according to EN 50075:1990



The connector conduct part can't be touched by test finger. CI & CR are measured according to table 2.10.3 & 2.10.4.

Appendix: Equipment's combined with Australian plug.

The Australian plug was tested according to Annex J of AS/NZS 3112:2011+A1:2012:

| Clause | Requirement – Test | Remark | Verdict |
|--------|---|--------|---------|
| 2.2 | PLUG PINS | | P |
| 2.2.1 | MATERIAL FOR PINS: - Copper alloy containing at least 58% copper for parts made from cold rolled sheet | | P |
| 2.2.2 | ASSEMBLY OF PINS - Assembled in factory and non-rewirable | | P |
| 2.2.3 | FORM OF PIN | | P |
| 2.2.4* | INSULATION OF PLUG PINS - Live parts of insulated pins plug are not exposed when plug is partially or fully engaged with the associated socket. | | P |
| 2.3 | INSULATING MATERIALS | | P |
| 2.3.1 | GENERAL | | P |
| 2.3.2 | PLUG BODY - Consisting of PBT which has properties not inferior to those specified in AS 3121 for insulating mouldings having a temperature class of 80°C | | P |
| 2.3.3 | PLUG COVER - Consisting of PVC which has properties not inferior to those specified in AS 3121 for insulating mouldings having a temperature class of 60°C | | P |
| 2.8 | RATINGS AND DIMENSIONS OF LOW VOLTAGE PLUGS - Comply with Figure 2.1 (c), rated 10A 250V~. - Distance between live pin and edge of plug moulding more than 9 mm | | P |
| 2.9 | INTERNAL CONNECTIONS -No earthing connection | | N/A |
| 2.10 | ARRANGEMENT OF EARTHING CONNECTIONS -No earthing connection | | N/A |

| Clause | Requirement – Test | Remark | Verdict |
|----------|--|--------|---------|
| 2.12 | MARKING (No marking is applicable for the integral plug portion. See markings for transformer) | | N/A |
| 2.12.6 | CONFIGURATION OF PLUGS - Figure 2.1 (c), the pin configuration is neutral and active in a clockwise direction | | P |
| 2.13 | TESTS ON PLUGS | | P |
| 2.13.3 | HIGH VOLTAGE TEST | | P |
| 2.13.7 | TUMBLING BARREL TEST | | P |
| 2.13.8 | TEMPERATURE RISE TEST | | P |
| 2.13.9 | SECUREMENT OF PLUG | | P |
| 2.13.9.1 | MOVEMENT OF PINS | | P |
| 2.13.9.2 | FIXING OF PINS | | P |
| 2.13.13 | ADDITIONAL TESTS ON THE INSULATION MATERIAL OF INSULATED PIN PLUGS | | P |

| <u>INSULATING MATERIALS TEST IN ACCORDANCE WITH AS/NZS 3121: 2002</u> | | | |
|---|--|--|---|
| 7.1 | General | | P |
| 7.2 | Resistance to heat test The moulding shall be placed in an oven and maintained for 6 h at the temperature appropriate to its class (see Clause 5) plus 10°C. The temperature of the oven during this period shall not vary by more than ± 5°C. The moulding shall show no physical or chemical change likely to impair the safety of the equipment of which it forms a part. | | P |
| 7.3 | Water absorption test The complete moulding shall be immersed in water at 20 °C ± 5°C for 48 h. The moulding shall not swell, delaminate, warp or show any physical change to a degree that would be liable to impair the safety of the equipment of which it forms a part. | | P |
| 7.4 | Resistance to white spirit test Sample shall be immersed in white spirit at room temperature for 2 min. | | P |



| | | | |
|--|---|--|--|
| | The moulding shall not blister, warp or show any physical or chemical change to a degree that would be liable to impair the safety of the equipment of which it forms a part. | | |
|--|---|--|--|

Appendix: Photos of Australian plug portion



The connector conduct part can't be touched by test finger. CI & CR are measured according to table 2.10.3 & 2.10.4.

Appendix: Equipment combined with NEMA 1-15 plug portion.

KEY:

- | | | | |
|----|--------------------------------|-----|--------------------|
| √ | = Complies. | G | = General comment |
| E | = Further evaluation required | N/A | = Not applicable |
| E√ | = Once “E” is found acceptable | T | = Testing required |
| F | = Non-compliance | TF | = Test failed |

| Section | Key | Comment |
|---------------------|-----|--|
| FORWARD | | |
| Introduction | | |
| 1 | | Scope |
| 1.1-1.4 | G | The device under evaluation is an integral plug for model GT*41134-***-*** input rating 100-240V~, 50-60Hz, 0.6A and model GT-41134-0606-W2-TAB input rating 100-240V~, 50-60Hz, 0.3A. The plug is evaluated according to rated input. |
| 2 | | Glossary |
| 2.1-2.38 | G | Noted. |
| 3 | | Components |
| 3.1-3.4 | G | Noted |
| 4 | | Units of Measurement |
| 4.1 | G | Noted |
| 5 | | Reference |
| 5.1 | G | Noted |
| CONSTRUCTION | | |
| | | ALL DEVICES |
| 6 | | General |
| 6.1 | √ | According to declared reasonable condition, 100-240VAC, 50-60Hz, has been considered in all following test. |
| 6.2 | √ | Plug for AC use only |
| 7 | | Configurations |
| 7.1 | √ | 1-15P plug applied. |
| 8 | | Insulating Materials |
| 8.1 | | General |
| 8.1.1 | √ | All parts that act as the electrical insulation or enclosure are made of plastic material. See 8.2.1 |
| 8.1.2 | N/A | Vulcanized fiber is not provided |
| 8.2 | | Flammability |
| 8.2.1 | √ | The insulating material required HB or more. For detailed parts, see report of end product) |
| 8.3 | | Electrical properties |
| 8.3.1 | √ | Exception No. 1: No information according to above table info. The insulating material has a CTI 3 (Required 3), so it need NOT comply with Comparative Tracking Index Test, Section 55. |
| 8.3.2 | √ | Exception No. 2: The insulating material has a HWI 3, (required HWI value is 4 when material class is V-0). According to 8.1.2 (UL746D) and reasonable usage, reasonable arcing occurs in normal use. We are of the opinion that it need NOT comply with Glow Wire Test, see Section 56. |

| Section | Key | Comment |
|-------------|-----|--|
| | | Exception No. 3: The insulating material has a HAI 2. (required HWI value is 4 when material class is V-0. or check if the thickness), since no arcing in normal use, so it need not comply with High-Current Arc Resistance to Ignition Test, Section 57. |
| 8.4 | | Thermal properties |
| 8.4.1 | √ | All the RTI rating of the insulating materials are higher than 80 degree (C) |
| 8.5 | | Vulcanized fiber |
| 8.5.1 | N/A | No Vulcanized fiber is provided |
| 8.5.2 | N/A | No Vulcanized fiber is provided |
| 8.6 | | Sealing compounds |
| 8.6.1-8.6.2 | N/A | Sealing compound is not provided, no need to comply with relevant requirement involved in ASTM 28. |
| 8.7 | | Fuse enclosures |
| 8.7.1-8.7.2 | N/A | Fuse is not provided |
| 9 | | Enclosure |
| 9.1 | | General |
| 9.1.1 | √ | Live parts of plug parts are protected against exposure to contact by persons when fully assembled using all essential parts. Exception no. 2: for fixed wiring. |
| 9.1.2-9.1.3 | N/A | No accessible dead-metal parts |
| 9.1.4 | √ | The probe shown in Figure 9.1 is used to judge the accessibility of a live or dead-metal part. The applied force is not more than 13.3N. |
| 9.1.5-9.1.7 | N/A | No such separable part |
| 9.2 | | Male faces and wire terminations |
| 9.2.1 | N/A | Not a 15 or 20A attachment plug or current tap |
| 9.2.2 | N/A | There is no exposed live part. |
| 9.2.3 | N/A | No such parts |
| 9.2.4-9.2.5 | √ | Probe not access to live parts. The cover is securely fixed for all acceptable wiring. |
| 9.2.6 | √ | The face plate is secure with the back part. |
| 10 | | Current-carrying Parts |
| 10.1 | | General |
| 10.1.1 | √ | Iron or steel is not used for current-carrying parts. |
| 10.1.2 | √ | The current-carrying parts are not able to be turned by means of general tools due to the appliance shroud mounted on Evaluated appliance. |
| 10.1.3 | N/A | No such uninsulated live parts except for female contact of connector |
| 10.2 | | Contacts (applying to the connector) |
| 10.2.1 | N/A | Female contacts of the connector cannot be touched by the probe. Others parts are covered by exception no. 3 |
| 11 | | Grounding and Dead Metal Parts |
| 11.1-11.10 | N/A | No grounding parts |
| 12 | | Terminals |
| 12.1-12.4 | | No terminals for end user |
| 13 | | Cord Entry and Strain Relief |
| 13.1-13.5 | N/A | Flexible cord part are considered in the end appliances. |
| 14 | | Spacings |
| 14.1 | √ | The spacing through air between uninsulated live parts of opposite polarity and between uninsulated live parts and exposed external surface is measured more than 2mm (required 3/36 inch, 1,2mm) for a device rated 250V or less. |

| Section | Key | Comment |
|--|-----|--|
| 14.2 | N/A | No such isolated dead-metal part |
| 15 | | Assembly |
| 15.1 | | General |
| 15.1.1 | √ | Pre-wired in factory |
| 15.1.2 | √ | Electrical contact is reliably maintained at any point |
| 15.1.3 | √ | Live parts is protected against exposure to persons |
| 15.1.4 | N/A | Not multiple outlet device |
| 15.1.5 | N/A | Female contacts of the connector can be mated with the inlet in right way without exposure of the blades |
| 15.2 | | Grounding and polarization |
| 15.2.1-15.2.4 | N/A | No grounding |
| 15.3 | | Mating and interchangeability |
| 15.3.1 | √ | The electrical continuity is automatically established. |
| 15.3.2-15.3.6 | √ | 1-15P receptacles ensuring. |
| 15.4 | | Fuseholders |
| 15.4.1-15.4.8 | N/A | Fuseholder is not provided |
| 15.5 | | Switches |
| 15.5.1 | N/A | The switch is provided between coupler 1 and coupler 2. but it is a information |
| ATTACHMENT PLUGS AND INLETS (for plug only) | | |
| 16 | | Insulating material |
| 16.1 | √ | The enclosure is measured min. 2.1 mm. |
| 17 | | Enclosure |
| 17.1 | | General |
| 17.1.1 | N/A | Not a general use plug. |
| 17.1.2 | √ | Measured 44 mm. |
| 17.1.3 | N/A | Not a 50A plug |
| 17.2 | | Grip |
| 17.2.1 | N/A | See section 69 |
| 17.3 | | Face size |
| 17.3.1 | √ | Larger than figure 17.1 |
| 18 | | Current carrying parts |
| 18.1 | N/A | Not a folded-over plug. |
| 18.2 | √ | Dimensional requirements fulfilled. |
| 19 | | Grounding and dead metal parts |
| 19.1-19.4 | N/A | No grounding or dead metal parts. |
| 20 | | Terminals and leads |
| 20.1-20.5 | N/A | All the assembly are pre-wired in factory |
| 21 | | Assembly |
| 21.1 | √ | The blades are held securely in place |
| 21.2 | N/A | Not a inlet |
| 21.3-21.4 | N/A | The device under evaluate is a plug part not inlet or surface mounting. |
| 21.5 | N/A | Not for radio antenna or ground. |

| Section | Key | Comment |
|--------------------|-----|--|
| 22 | | Weatherproof type |
| 22.1-22.2 | N/A | Not weatherproof type |
| 23-26 | N/A | CONNECTORS |
| 27-37 | N/A | RECEPTACLES |
| | | SELF-CONTAINED RECEPTACLES FOR USE WITHOUT A SEPARATE OUTLET BOX |
| 38-44 | N/A | These sections are applicable for self-contained receptacles. |
| | | CURRENT TAPS |
| 45 | N/A | The section is applicable for current taps only |
| | | FLATIRON AND APPLIANCE PLUGS |
| 46-53 | N/A | These sections are applicable for flatiron and appliance plugs. |
| PERFORMANCE | | |
| | | GENERAL |
| 54 | | Representative Devices |
| 54.1-54.7 | G | Noted. |
| | | ALL DEVICES |
| 55 | | Comparative Tracking Index Test |
| 55.1 | N/A | Refer to Exception No. 2 of 8.3.2. Not main tests but the test is considered |
| 56 | | Glow Wire Test |
| 56.1-56.2 | N/A | Refer to Exception No. 2 of 8.3.2, Not main tests but the test is considered |
| 57 | | High-Current Arc Resistance to Ignition Test |
| 57.1-57.6 | G | Refer to Exception No. 3 of 8.3.2 |
| 58 | | Mold Stress Relief |
| 58.1-58.2 | T | All devices are placed in air oven maintained at a 80oC for 7 hours. After 58.2, there is not any warpage, shrinkage or other distortion. |
| 58.3 | T | Refer to data sheet. Repeat dielectric voltage-withstand test as described in section 60. Not required to be subjected to the humidity conditioning described in 60.1.2. |
| 59 | | Moisture Absorption Resistance |
| 59.1-59.2 | T | Refer to data sheet |
| 60 | | Dielectric Withstand Test |
| 60.1-60.2 | T | Refer to data sheet |
| 61 | | Accelerated Aging Tests |
| 61.1 | | General |
| 61.1.1 | G | Exception to 8.4.1 for other material is not applicable for the devices under evaluation |
| 61.2 | | Rubber, EPDM, and TEE compounds |
| 61.2.1-61.2.4 | N/A | Not a rubber , EPDM, and TEE compounds |
| 61.3 | | PVC compounds and copolymers |
| 61.3.1-61.3.2 | G | See 61.1.1 shown as above |
| 62 | | Insulation Resistance Test |
| 62.1-62.6 | T | Refer to data sheet |
| 63 | | Conductor Secureness Test |
| 63.1-63.2 | N/A | No wire leads provided. |
| 64 | | Tightening Torque Test |

| Section | Key | Comment |
|----------------------------------|-----|--|
| 64.1-64.2 | N/A | Not provide any wire-binding screw |
| | N/A | ATTACHMENT PLUGS |
| 65 | | General |
| 65.1 | G | Noted. |
| 66 | | Security of blades test |
| 66.1-66.2 | T | Refer to data sheet |
| 67 | | Secureness of cover test |
| 67.1-67.2 | T | Refer to data sheet |
| 68 | | Crushing test |
| 68.1-68.2 | T | Refer to data sheet |
| 69 | | Attachment plug grip test |
| 69.1-69.9 | T | Refer to data sheet |
| 70 | | Integrity of assembly test |
| 70.1-70.2 | N/A | Cord part shall be considered in the end appliance. |
| 71 | | Self-hinge Flexing test |
| 71.1-71.3 | N/A | Not self-hinge type |
| 72 | | Terminal temperature test |
| 72.1-72.4 | N/A | No terminal for end user. |
| 73 | | Fuse-holder temperature test |
| 73.1-73.8 | N/A | No fuse-holder applied. |
| 74-79 | N/A | Pin type terminal |
| 80-85 | N/A | INLET (applying for inlet) |
| 86-103 | N/A | CONNECTORS |
| 104-150 | N/A | RECEPTACLES |
| | | CURRENT-TAPS |
| | | All devices |
| 151-152 | N/A | These sections are for current-taps |
| | | Flatiron and appliance plugs. |
| 153-161 | N/A | These sections are applicable for flatiron and appliance plugs. |
| RATINGS | | |
| 162 | | Details |
| 162.1 | G | According to exception no. 2, rating is not required. The special-use device is not intended to ship out solely. (Note: plug is mounted in evaluated appliance). |
| 162.2 | √ | Rating of 1A 120V~ is evaluated |
| 162.3 | √ | 0.5HP rated. |
| 162.4-162.7 | N/A | Not have the specified devices |
| MARKINGS AND INSTRUCTIONS | | |
| 163 | | General |
| 163.1-163.2 | G | The location of the catalog number is not prohibited from appearing according to exceptions of table 163.1 and 163.2 |
| 164 | | Identification and marking of terminals |
| 164 | G | No any grounding parts and terminals |
| SUPPLEMENT SA | | (reserved for future use) |

| Section | Key | Comment |
|----------------------|------------|--|
| SUPPLEMENT SB | | ENCLOSURE TYPES FOR ENVIRONMENTAL PROTECTION |
| SB1-SB7 | N/A | The requirements of SB don't apply to the device under evaluation for it's intended for indoor use only (refer to SB1.1) |
| SUPPLEMENT SC | | MARINE SHORE POWER INLETS |
| SC1-SC12 | N/A | These sections are for marine shore power inlets |
| SUPPLEMENT SD | | HOSPITAL GRADE DEVICES |
| SD1-SD30 | N/A | These sections are for hospital grade devices |

Appendix: Dimensions of NEMA 1-15 plug portion

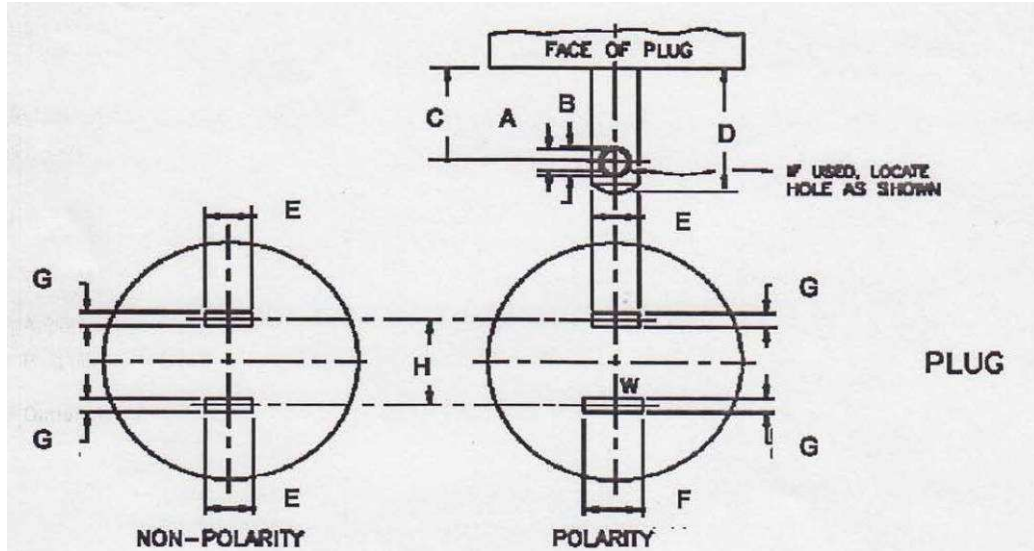

| Symbol | Requirement (inch) | Measured (inch) | Symbol | Requirement (inch) | Measured (inch) |
|---|--------------------|-----------------|--------|--------------------|-----------------|
| A | 0.120 – 0.130 | 0.123 | E | 0.240 – 0.260 | 0.248 |
| B | 0.151 – 0.161 | 0.157 | F | 0.307 – 0.322 | -- |
| C | 0.449 – 0.479 | 0.466 | G | 0.055 – 0.065 | 0.057 |
| D | 0.625 – 0.718 | 0.656 | H | 0.495 – 0.505 | 0.498 |
| Perimeter faces to the plug blades shall not be less than 7.9 mm (intended for use with children’s toys) or 5.1 mm from any point of either blade | | | | | 12.39 |

For model GT-41134-0606-W2-TAB

| Symbol | Requirement (inch) | Measured (inch) | Symbol | Requirement (inch) | Measured (inch) |
|---|--------------------|-----------------|--------|--------------------|-----------------|
| A | 0.120 – 0.130 | 0.124 | E | 0.240 – 0.260 | 0.251 |
| B | 0.151 – 0.161 | 0.159 | F | 0.307 – 0.322 | -- |
| C | 0.449 – 0.479 | 0.465 | G | 0.055 – 0.065 | 0.058 |
| D | 0.625 – 0.718 | 0.676 | H | 0.495 – 0.505 | 0.498 |
| Perimeter faces to the plug blades shall not be less than 7.9 mm (intended for use with children’s toys) or 5.1 mm from any point of either blade | | | | | 9.9 |

Appendix: Photos for NEMA 1-15 plug portion.



The connector conduct part can't be touched by test finger. CI & CR are measured according to table 2.10.3 & 2.10.4.

Appendix: Equipment combined with BS-plug portion

Supplementary tests on plug portion according to BS1363: Part 3 + Amd 9543 + Amd 14225 + Amd 14540 + Amd 17437 + Amd A4

| Clause | Requirement - Test | Result-Remark | Verdict |
|--------|--|------------------------|---------|
| 12.1 | Dimensions (Checked according to figure 4) | See appendix no. 1 & 2 | P |
| 12.2 | Outline of plug shall not exceed the dimension shown in Figure 4 for a distance of not less than 6.35 mm from the engagement surface | 8.90 mm | P |
| | Pin disposition, length and body outline shall be checked by use of the gauge shown in Figure 5 | | P |
| 12.3 | L/N pin was more than 9.5 mm from the periphery of the plug measured along the engagement surface | 9.60 mm | P |
| 12.7 | The base and cover of rewirable plugs shall be adaptor plugs having the cover fixed by screws shall be firmly secured to each other. It shall not be possible to remove the cover unless the adaptor is completely withdrawn from the socket-outlet. Fixing screws shall be captive. The test is carried out using apparatus similar to that shown in Figure 6 | | N/A |
| 12.9 | After the temperature rise test (clause 16). Use test probe 11 of BS EN 61032:1998 is applied a force 30 -5/0 N. During and after the test, it was not possible to touch the live parts. | | P |
| 12.11 | Adaptor plug pins shall be constructed of brass, except for sleeves of pins as specified in 12.18 | | P |
| | All exposed surfaces of the adaptor plug pins shall be smooth and free from burrs or sharp edges and other irregularities which could cause damage or excessive wear to corresponding socket contacts or shutters. | | P |
| | Those surfaces of the non-solid adaptor plug pins which are visible when the adaptor is correctly assembled shall be free of apertures. | | P |
| | All seams and joints of non-solid adaptor plug pins shall be closed over their entire length. | | P |
| | For solid pins, conformity shall be checked by 12.11.4.1. | | P |
| | For non-solid pins, compliance shall be checked by 12.11.4.2. | | N/A |

| Clause | Requirement - Test | Result-Remark | Verdict |
|---------|---|---------------|---------|
| | Adaptors with non-solid pins shall not cause excessive wear to socket contacts or shutters of socket-outlets in accordance with BS 1363-2:1995. | | N/A |
| | Adaptor plug pins shall have adequate mechanical strength to ensure that they cannot be distorted by twisting. Apply a torque $1\text{N.m} \pm 10\%$ for $60 +5/0 \text{ S}$. After each pin has been separately twisted, the plug was fit the gauge in fig. 5. Repeated with opposite direction. | | P |
| 12.13 | Adaptors shall be so designed that when fully assembled the pins are adequately retained in position such that there is no likelihood of them becoming detached from the adaptor during normal use. | | P |
| | Each pin is subjected for $60 +5/0 \text{ S}$ to a pull of $100 -2/0 \text{ N}$ without jerks in the direction of the major axis. The plug is mounted using the steel plate shown in fig.7. The apparatus is placed within an oven and the pull is applied at least 1 h after the plug body has attained the test temperature of $70^{\circ}\text{C} \pm 5^{\circ}\text{C}$ while maintained at this temperature. After the test, the plug pin shall fit into the gauge and comply with 12.2.1. | | P |
| 12.14 | The degree of flexibility of mounting of the plug pins or the angular movement of the pins in the base shall be not greater than $3^{\circ} 30'$. See fig. 8. | | P |
| | Test procedure refers to standard. During each test, the declination from the horizontal measured on the scale shall not exceed $3^{\circ} 30'$ and comply with 12.2.1. | | P |
| 12.18 | Live and neutral adaptor plug pins shall be fitted with insulating sleeves. See fig.4. Sleeves shall not be fitted to any earthing adaptor plug pin. | | P |
| 12.19.3 | Abrasion test – 10 000 times in each direction (20 000 movements) at a rate of 25 movements to 30 movements per min. (fig. 9). After the test, the sleeve shall show no damage and also shall not have been penetrated or creased, satisfy the tests in 12.19.2. | | P |

| Clause | Requirement - Test | Result-Remark | Verdict |
|---|--|-----------------------------------|---------|
| 13.10 | The total mass of the equipment with all specified connectors shall not exceed 800 g. The torque exerted on a socket shall not exceed 0.7 N·m. The test apparatus as Figure 37 | Compliance with the main standard | N/A |
| | Additional: Products with torque exceeding 0.25Nm do not comply with the main standard hence full compliance with the main standard cannot be claimed | | N/A |
| Additional test for ISODs according to BS1363: Part 1 + Amd 9541 + Amd 14539 + Amd 17435 + Amd A4 | | | |
| 12.9.1 | All exposed surfaces of plug pins shall be smooth and free from burrs or sharp edges and other irregularities which could cause damage or excessive wear to corresponding socket contacts or shutters. | | P |
| 12.9.4 | Apply a force of 1100 -10/0N at a rate not exceeding 10 mm/min. After this test the plug should fit the gauge to fig. 5. | | P |
| | Apply a force of 400 +10/0N at a rate 10 ± 2 mm/min. Deflection shall not exceed 1.5 mm. After this test the plug should fit the gauge to fig. 5. | | P |
| 12.9.6 | ISODs shall have adequate mechanical strength to ensure that they cannot be distorted by twisting. Apply a torque 1N.m ± 10% for 60 +5/0 S. After each pin has been separately twisted, the plug shall fit the gauge in fig. 5. Repeated with opposite direction. | | P |

Appendix: Dimensions of BS1363 plug portion

| Dimensions Checked by means of measurement according to BS1363-3 Fig. 4 (see appendix no. 2) | | | |
|--|-------------------|-------------------|---------|
| Position | Requirement (mm) | Measured (mm) | Verdict |
| 1 | 25.37max | 24.02 | P |
| 2 | 25.37max | 24.02 | P |
| 3 | R15min | Measured by gauge | P |
| 4 | R9.5min | 9.60 | P |
| 5 | R9.5min | 9.60 | P |
| 6 | 11.05-11.18 | 11.12 | P |
| 7 | 11.05-11.18 | 11.12 | P |
| 8 | 34.6max | 30.50 | P |
| 9 | 22.23-23.23 | 22.60 | P |
| 10 | 1.35-1.85 | 1.55 | P |
| 11 | 7.80-8.05 | 8.03 | P |
| 12 | 58°-62° inclusive | 60° | P |
| 13 | 3.90-4.05 | 3.99 | P |
| 14 | 9.2max | 8.88 | P |
| 15 | 17.2-18.2 | 18.05 | P |
| 16 | 9.5max | 9.17 | P |
| 17 | 22.10-22.36 | 22.21 | P |
| 18 | 6.22-6.48 | 6.26 | P |
| 19 | 3.90-4.05 | 4.03 | P |
| 20 | 6.22-6.48 | 6.26 | P |
| 21 | 1.35-1.85 | 1.81 | P |
| 22 | 3.90-4.05 | 3.98 | P |
| 23 | 1.2-2.0 | 1.24 | P |
| 24 | R0.1-R1.0 | R0.55 | P |
| 25 | 60°-80° inclusive | 68° | P |
| Outline of the plug not exceed the dimension shown in figure 4 at least 6.35mm from the engagement surface | | 8.90 | P |

Appendix: Concave shrinkable allowance for ISODs

| Dimensions Checked by means of measurement according to BS1363-1 Fig. 4b | | | |
|--|------------------|---------------|---------|
| Position | Requirement (mm) | Measured (mm) | Verdict |
| 1 | 7.75-8.05 | 8.03 | P |
| 2 | 3.90-4.05 | 3.99 | P |
| 3 | ≤ 0.15 | 0.01 | P |
| 4 | ≤ 0.15 | 0.01 | P |
| 5 | ≤ 0.15 | 0.01 | P |
| 6 | ≤ 0.15 | 0.01 | P |

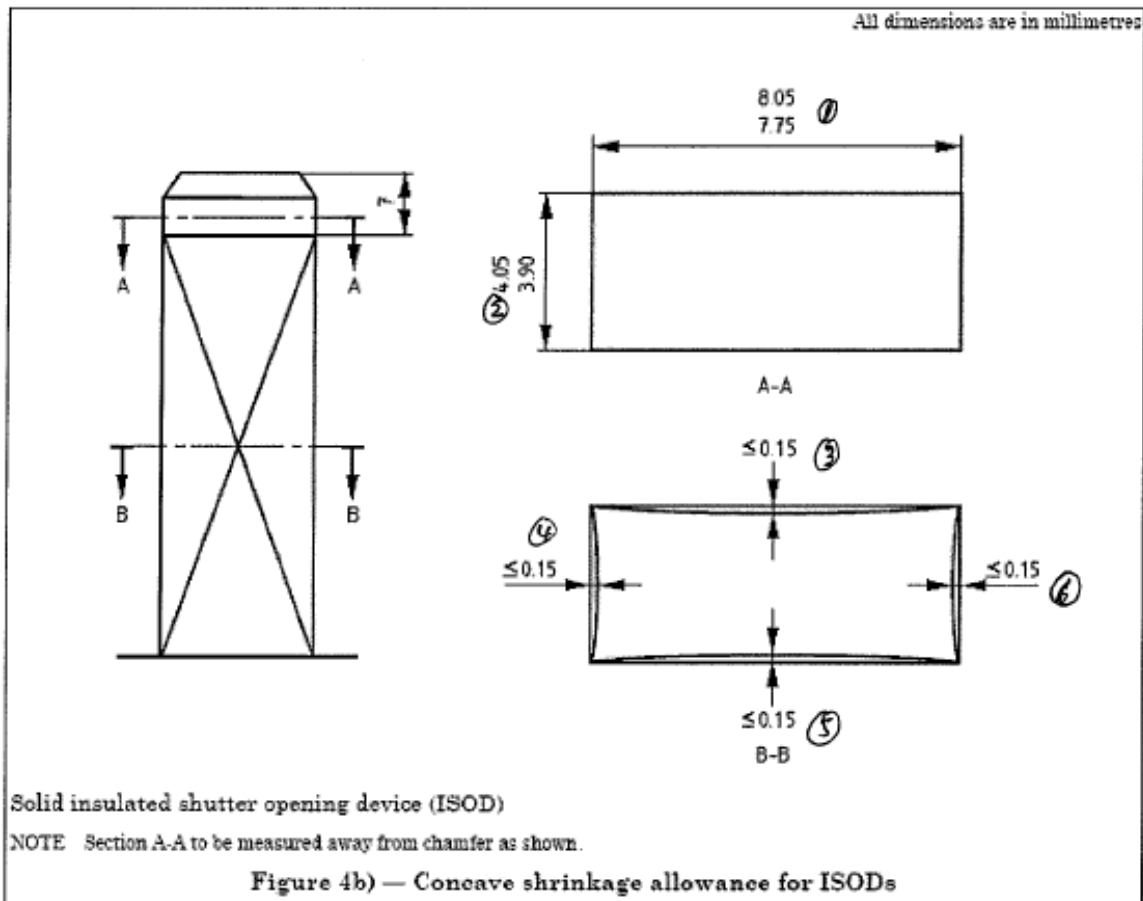

Appendix: Photo for BS1363 plug



The connector conduct part can't be touched by test finger. CI & CR are measured according to table 2 10 3 & 2 10 4

Appendix: Specification of NBR 14136 plug

所有权利保留:
 本文件所有权利属于 GLOBTEK 公司, 任何团体和个人的复制和分发禁止和非法的, 除非取得 GLOBTEK 公司的授权许可。
 PROPRIETARY OF GLOBTEK, INC. ANY REPRODUCTION, DISCLOSURE OR USE OF THIS DRAWING IN WHOLE OR PART IS HEREBY PROHIBITED EXCEPT AS SPECIFIED IN WRITING BY GLOBTEK, INC.

REV A
 DESCRIPTION Initial Release
 DATE 2012.01.09
 APPROVED DAVID

Attachment to Report No.: 15057220 002

Note:

- No label tolerance refer to tolerance sheet.
- "*" is the important dimension.
- Plastic material: PC+ABS 94-V0.
- Color: Black.
- Metel pin material: Brass.
- Metel pin Finish: nickelage.

| Tolerance table | | |
|-----------------|-------------------------|--------|
| RANGE | GRADE 1 GRADE 2 GRADE 3 | |
| 0-4 | +/-0.05/ +/-0.1 | +/-0.2 |
| 4-16 | +/-0.08/ +/-0.15 | +/-0.3 |
| 16-64 | +/-0.12/ +/-0.25 | +/-0.5 |
| 64-250 | +/-0.25/ +/-0.4 | +/-0.8 |

规格:
 本图所规定之规格, 公司未经核准不得擅自修改零件之规格, 如有任何变更, 须经用户同意, 并经 UL、CSA 认证核准后方可变更。

适用范围:
 本图所规定之规格, 产品规格不得用于任何未经授权之用途, 且不得用于任何未经授权之用途, 且不得用于任何未经授权之用途。

Foot Note:
 Intertek will not be liable for the safety and performance of these parts if user should contact applicable UL, CSA or EN standards for proper installation instructions.

批准:
 本图所规定之规格, 产品规格不得用于任何未经授权之用途, 且不得用于任何未经授权之用途, 且不得用于任何未经授权之用途。

适用范围:
 本图所规定之规格, 产品规格不得用于任何未经授权之用途, 且不得用于任何未经授权之用途, 且不得用于任何未经授权之用途。

Foot Note:
 Intertek will not be liable for the safety and performance of these parts if user should contact applicable UL, CSA or EN standards for proper installation instructions.

APPROVAL FLOW: 1 CUSTOMER (INHOUSE/OUTSIDE) 2 ENG G MANAGER (CHECK REVIEW) 3 MECH ENGR (DRAW CHECK) 4 ENG G MANAGER (REVIEW/APPROVE/FILE KEEPING/ENGR and QA ASSISTANT) 5 OPEN MANAGER 6 RELEASE TO MECH ENGR 7 END CUSTOMER (INHOUSE/OUTSIDE)

450-02070214(R)
 TOLERANCES:
 GRADE 1
 DWG Title: Q-BRZNL DRAWING FOR GT-41052 BTM-CASE
 MODEL NO: Q-BR PART NO: N/A
 SHEET 1 OF 1

Appendix: Evaluation sheet of NBR 14136 Figure 13 plug

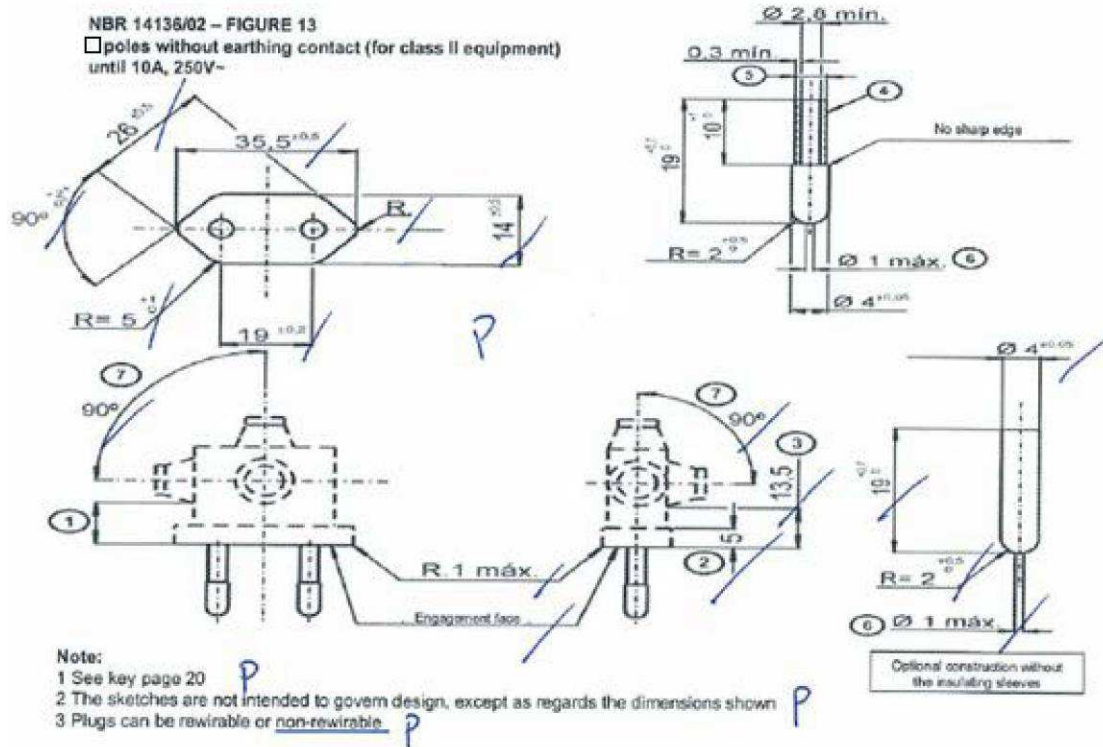

Key of page 20:

- 1- The distance between the engagement face and the cord or cord guard, if any, shall be at least 14 mm P
- 2- Within this distance, the outline shall be not smaller than the engagement face. P
- 3- Within this distance, the outline shall be not larger than the engagement face. P P
- 4- Insulating sleeves on the current-carrying pins are optional N/A
- If the insulating sleeves are separate parts, they shall enter the plug by at least 3mm measured from the engagement face. N/A
- 5- The external diameter of the insulating sleeves shall not be larger than the diameter of the uninsulated part of the pins. N/A
- 6- To avoid damage to shutters, the ends of the pins shall show neither sharp edges nor burrs. They shall be of rounded shape as shown. P
- 7- The angle of 90° represents the maximum permissible area for the orientation of the entry of the flexible cable or cord. P

Plug Marking for the 10A 250V~ Plug:

- Cable section of 0.5mm² - 2.5A 250V~ P
- Cable section of 0.75mm² - 10A 250V~
- Cable section of 1mm² - 10A 250V~
- Cable section of 1.5mm² - 10A 250V~
- Cable section of 2.5mm² - 10A 250V~

Appendix: Evaluation sheet of IRAM 2063 plug

| | | | |
|--------|---|---|----------|
| 25 | RESISTANCE TO HEAT | | |
| 25.2 | Parts of insulating material of fixed socket-outlets necessary to retain current-carrying parts and parts of the earthing circuit in position, as well as parts of the front surface zone of 2 mm wide surrounding the phase and neutral pin entry holes: ball-pressure test at $(125 \pm 2)^\circ\text{C}$ for 1 h | | P |
| | After the test: diameter of impression ≤ 2 mm | 0.67 mm | P |
| 25.3 | For parts not necessary to retain current-carrying parts and parts of the earthing circuit in position, even though in contact with them: ball-pressure test (1 h) | | --- |
| | Test temperature ($^\circ\text{C}$) | $(70 \pm 2^\circ\text{C}) / (40 \pm 2)^\circ\text{C} +$ highest temperature rise determined during the test of clause 19 | --- |
| | After the test: diameter of impression ≤ 2 mm | | --- |
| 28 | RESISTANCE OF INSULATING MATERIAL TO ABNORMAL HEAT, TO FIRE AND TO TRACKING | | P |
| 28.1 | Resistance to abnormal heat and to fire | | P |
| 28.1.1 | Glow-wire test | | |
| | For parts of fixed accessories necessary to retain current-carrying parts and parts of the earthing circuit in position: test temperature 850°C | | P |
| | No visible flame and no sustained glowing | | P |
| | Flame and glowing extinguish within 30 s | | P |
| | No ignition of the tissue paper | | P |
| | For parts of fixed accessories needed to retain the earth terminal in position in a box: test temperature 650°C | | --- |
| | No visible flame and no sustained glowing | | --- |
| | Flame and glowing extinguish within 30 s | | --- |
| | No ignition of the tissue paper | | --- |
| | For parts of portable accessories necessary to retain current-carrying parts and parts of the earthing circuit in position: test temperature 750°C | | P |
| | No visible flame and no sustained glowing | | P |
| | Flame and glowing extinguish within 30 s | | P |
| | No ignition of the tissue paper | | P |
| | For parts not necessary to retain current-carrying parts and parts of the earthing circuit in position, even though in contact with them: test temperature 650°C | | --- |
| | No visible flame and no sustained glowing | | --- |
| | Flame and glowing extinguish within 30 s | | --- |
| | No ignition of the tissue paper | | --- |

| | | | |
|--------------|------------------|--|----------|
| 28.1 | Table: Glow wire | | P |
| Tested part: | | Temperature of test ($^\circ\text{C}$) | Result |
| Plug | | 850 | P |

Appendix: Evaluation sheet of IRAM 2063 plug

| 6.4 | PLUG PINS MEASUREMENT | | |
|-----------------------|-----------------------|-------------------------|---------|
| | Measured in mm | Allowed in mm | Verdict |
| - Phase Pin: | | | |
| Length: | 18.03,18.05,18.04 | 18,2 ± 0,2 (18.0/18.4) | P |
| Wide: | 6.25,6.26,6.25 | 6,25 ± 0,1 (6.15/6.35) | P |
| Thickness: | 1.57,1.55,1.56 | 1,55 ± 0,07 (1.48/1.62) | P |
| - Neutral Pin: | | | |
| Length: | 18.10,18.09,18.08 | 18,2 ± 0,2 (18.0/18.4) | P |
| Wide: | 6.23, 6.25,6.23 | 6,25 ± 0,1 (6.15/6.35) | P |
| Thickness: | 1.51,1.51,1.52 | 1,55 ± 0,07 (1.48/1.62) | P |
| - Pin of earth | | | |
| Length: | --- | 21,4 ± 0,2 (21.2/21.6) | --- |
| Wide: | --- | 6,25 ± 0,1 (6.15/6.35) | --- |
| Thickness: | --- | 1,55 ± 0,07 (1.48/1.62) | --- |
| Perimeter: | 11.86.11.86, 11.85 | ≥ 8mm | P |
| Comments: | - | | |

Photo:

