

XStream-PKG-R™ RS-232/485 RF Modem

XStream RS-232/485 RF Modem
Interfacing Protocol
RF Modem Operation
RF Modem Configuration
Appendices



Product Manual v4.2B5

For XStream RF Modem Part Numbers:

X09-001PK...-R...
X09-009PK...-R...
X09-019PK...-R...

X24-009PK...-R...
X24-019PK...-R...

XH9-001PK...-R...
XH9-009PK...-R...
XH9-019PK...-R...

900 MHz & 2.4 GHz Stand-alone RF Modems by MaxStream, Inc.

MaxStream™
355 South 520 West, Suite 180
Lindon, UT 84042
Phone: (801) 765-9885
Fax: (801) 765-9895

rf-xperts@maxstream.net
www.maxstream.net

M100019
2006.02.27

© 2006 MaxStream, Inc. All rights reserved

The contents of this manual may not be transmitted or reproduced in any form or by any means without the written permission of MaxStream, Inc.

XStream™ is a trademark of MaxStream, Inc.

Technical Support

Phone: (801) 765-9885

Live Chat: www.maxstream.net

E-Mail: rf-xperts@maxstream.net

Contents

| | | | |
|--|-----------|---|-----------|
| 1. XStream RS-232/485 RF Modem | 4 | Appendix A: Agency Certifications | 36 |
| 1.1. Features | 4 | FCC Certification | 36 |
| 1.1.1. Worldwide Acceptance | 4 | OEM Labeling Requirements | 37 |
| 1.2. Specifications | 5 | Antenna Usage | 37 |
| 1.3. External Interface | 6 | FCC-Approved Antennas | 38 |
| 2. Interfacing Protocol | 7 | European Compliance (2.4 GHz only) | 39 |
| 2.1. RS-232 Operation | 7 | Restrictions | 39 |
| 2.1.1. DIP Switch Settings and Pin Signals | 7 | Europe (2.4 GHz) Approved Antenna List | 40 |
| 2.2. RS-485 (2-wire) Operation | 9 | IC (Industry Canada) Certification | 40 |
| 2.2.1. DIP Switch Settings and Pin Signals | 9 | Appendix B: Development Guide | 41 |
| 2.3. RS-485 (4-wire) & RS-422 Operation | 10 | RS-232 Accessories Kit Contents | 41 |
| 2.3.1. DIP Switch Settings and Pin Signals | 10 | Adapters | 42 |
| 3. RF Modem Operation | 12 | Antennas | 43 |
| 3.1. Serial Communications | 12 | Appendix C: Additional Information | 44 |
| 3.1.1. RS-232 and RS-485/422 Data Flow | 12 | 1-Year Warranty | 44 |
| 3.1.2. Host and RF Modem I/O Settings | 12 | Ordering Information | 44 |
| 3.1.3. Flow Control | 13 | Contact MaxStream | 45 |
| 3.2. Modes of Operation | 14 | | |
| 3.2.1. Idle Mode | 14 | | |
| 3.2.2. Transmit Mode | 14 | | |
| 3.2.3. Receive Mode | 16 | | |
| 3.2.4. Sleep Modes | 16 | | |
| 3.2.5. Command Mode | 19 | | |
| 4. RF Modem Configuration | 21 | | |
| 4.1. Automatic DIP Switch Configurations | 21 | | |
| 4.2. Programming the Modem | 22 | | |
| 4.2.1. AT Command Examples | 22 | | |
| 4.2.2. Binary Command Example | 23 | | |
| 4.3. Command Reference Table | 24 | | |
| 4.4. Command Descriptions | 25 | | |

1. XStream RS-232/485 RF Modem

The XStream-PKG-R RF Modem provides long range data communications and advanced networking for OEMs and system integrators. Out-of-box, the modem is equipped to sustain long range wireless links between devices. Simply enter serial data into one modem and the data surfaces on the other end of the wireless link.



The modem transfers a standard asynchronous serial data stream between two or more modems. Its built-in RS-232/485/422 interfacing facilitates rapid integration into existing data systems.

1.1. Features

Long Range

9XStream-PKG-R (900 MHz) Range:

- Indoor/Urban: **up to 1500'** (450 m)
- Outdoor line-of-sight: **up to 7 miles** (11 km) w/ 2.1 dBm dipole antenna
- Outdoor line-of-sight: **up to 20 miles** (32 km) w/ high gain antenna

24XStream-PKG-R (2.4 GHz) Range:

- Indoor/Urban: **up to 600'** (180 m)
- Outdoor line-of-sight: **up to 3 miles** (5 km) w/ 2.1 dBm dipole antenna
- Outdoor line-of-sight: **up to 10 miles** (16 km) w/ high gain antenna

Receiver Sensitivity: **-110 dBm** (900 MHz), **-105 dBm** (2.4 GHz)

Advanced Networking & Security

True peer-to-peer (no "master" required), point-to-point, point-to-multipoint, multidrop
Retries and Acknowledgements
7 hopping channels, each with over 65,000 available network addresses
FHSS (Frequency Hopping Spread Spectrum)

Easy-to-Use

Out-of-Box RF Communications - no configuration required

External DIP Switch for configuring:

- RS-232/485/422 support (multidrop included)
- 2-wire (half-duplex) or 4-wire RS-485/422 operation
- Parity options

7-18 VDC power supply

Simple AT and Binary commands for programming the modem

Software-selectable serial interfacing rates

MODBUS, CTS, RTS, DTR, DCD (& more) I/O Support

XII™ Interference Blocking

Power-saving Sleep Modes (as low as 6 mA)

Free & Unlimited

World-Class Technical Support

1.1.1. Worldwide Acceptance

FCC Certified (USA) - Refer to Appendix A for FCC Requirements.

Systems that contain XStream RF Modems inherit MaxStream's FCC Certification.

ISM (Industrial, Scientific & Medical) frequency band

Manufactured under **ISO 9001:2000 registered standards**

9XStream (900 MHz) RF Modems are approved for use in **US, Canada, Australia & Israel** (and more). 24XStream (2.4 GHz) Modems add **Europe** (EU) and other approvals.



1.2. Specifications

Table 1.1. XStream-PKG-R RS-232/485 RF Modem Specifications

| Specification | 9XStream-PKG-R (900 MHz) | | 24XStream-PKG-R (2.4 GHz) | |
|---|--|------------|---|------------|
| Performance | | | | |
| Indoor/Urban Range | Up to 1500' (450 m) | | Up to 600' (180 m) | |
| Outdoor LOS Range | Up to 7 miles (11 km) w/ dipole antenna Up to 20 miles (32 km) w/ high-gain antenna | | Up to 3 miles (5 km) w/ dipole antenna Up to 10 miles (16 km) w/ high-gain antenna | |
| Transmit Power Output | 100 mW (20 dBm) | | 50 mW (17 dBm) | |
| Interface Data Rate | 125 – 65,000 bps (software selectable) | | 125 – 65,000 bps (software selectable) | |
| Throughput Data Rate | 9,600 bps | 19,200 bps | 9,600 bps | 19,200 bps |
| RF Data Rate | 10,000 bps | 20,000 bps | 10,000 bps | 20,000 bps |
| Receiver Sensitivity | -110 dBm | -107 dBm | -105 dBm | -102 dBm |
| Power Requirements | | | | |
| Supply Voltage | 7-18 VDC | | 7-18 VDC | |
| Receive Current | 70 mA | | 90 mA | |
| Transmit Current | 170 mA | | 180 mA | |
| Pin Sleep Power-Down | 6 mA | | 6 mA | |
| General | | | | |
| Frequency | 902-928 MHz | | 2.4000-2.4835 GHz | |
| Spread Spectrum | Frequency Hopping, Wide band FM modulator | | Frequency Hopping, Wide band FM modulator | |
| Network Topology | Peer-to-Peer, Point-to-Multipoint, Point-to-Point, Multidrop | | Peer-to-Peer, Point-to-multipoint, Point-to-Point, Multidrop | |
| Channel Capacity | 7 hop sequences share 25 frequencies | | 7 hop sequences share 25 frequencies | |
| Data Connection | DB-9 | | DB-9 | |
| Physical Properties | | | | |
| Enclosure | 7.1 oz. (200g), Extruded aluminum, black anodized | | 7.1 oz. (200g), Extruded aluminum, black anodized | |
| Enclosure Size | 2.750" x 5.500" x 1.125" (6.99cm x 13.97" x 2.86cm) | | 2.750" x 5.500" x 1.125" (6.99cm x 13.97" x 2.86cm) | |
| Operating Temperature | 0 to 70° C (commercial), -40 to 85° C (industrial) | | 0 to 70° C (commercial), -40 to 85° C (industrial) | |
| Antenna | | | | |
| Type | ½ wave dipole whip, 6.75" (17.1 cm), 2.1 dBi Gain | | ½ wave dipole whip, 5.25" (13.3 cm), 2.1 dBi Gain | |
| Connector | Reverse-polarity SMA | | Reverse-polarity SMA | |
| Impedance | 50 ohms unbalanced | | 50 ohms unbalanced | |
| Certifications (Refer to www.maxstream.net for additional certifications) | | | | |
| FCC Part 15.247 | OUR9XSTREAM | | OUR-24XSTREAM | |
| Industry Canada (IC) | 4214A-9XSTREAM | | 4214A 12008 | |
| Europe | N/A | | ETSI, CE | |

1.3. External Interface

Figure 1.1. Front View

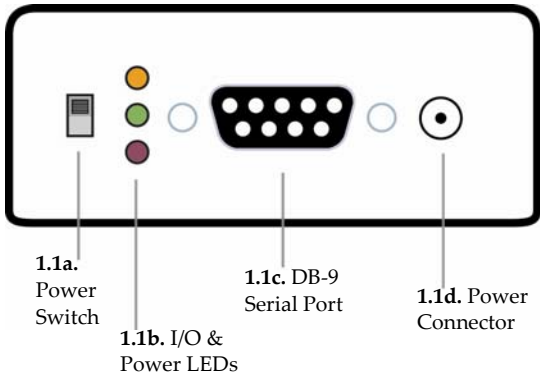

1.1a. Power Switch

Move the Power Switch to the on (up) position to power the Interface Board. DIP Switch [1.2a] settings are only read during a power-up sequence.

1.1b. I/O & Power LEDs

The LED indicators visualize diagnostic status information. The modem's status is represented as follows:

Yellow (top LED) = Serial Data Out (to host)

Green (middle) = Serial Data In (from host)

Red (bottom) = Power/TX Indicator (Red light is on when powered, off briefly during RF transmission)



1.1c. Serial Port (DB-9 Connector)

Standard female DB-9 (RS-232) DCE connector – This connector can be also used for RS-485 and RS-422 connections.

1.1d. Power Connector

7-18 VDC Power Connector (Center positive, 5.5/2.1mm) – Power can also be supplied through Pin 9 of the DB-9 Serial Port.

Figure 1.2. Back View

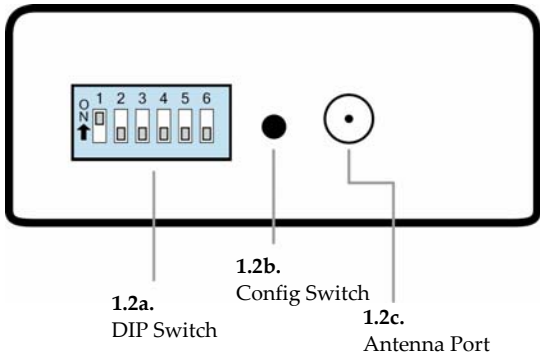

1.2a. DIP Switch

The DIP Switch automatically configures the XStream RF Modem to operate in different modes. Each time the modem is powered-on, intelligence inside the XIB-R interface board (inside the modem) programs the modem according to the positions of the DIP Switch. [See figure below for DIP Switch settings]

NOTE: In cases where AT Commands should not be sent each time the RF Modem is powered-on, the processor must be disabled by populating J7 on the interface board inside the modem [p21].

1.2b. Config (Configuration) Switch

The Configuration Switch provides an alternate way to enter "AT Command Mode". To enter "AT Command Mode" at the RF modem's default baud rate, hold the Configuration Switch down while powering on the modem using the Power Switch [1.1a].

1.2c. Antenna Port

Port is a 50Ω RF signal connector for connecting to an external antenna. The connector type is RPSMA (Reverse Polarity SMA) female.

The connector has threads on the outside of a barrel and a male center conductor.

Figure 1.3. DIP Switch Settings

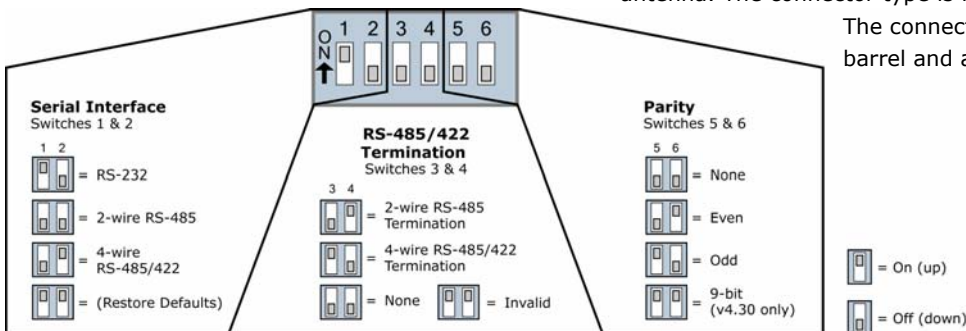

Refer to table in the "Automatic DIP Switch Configurations" [p21] section for more information about configurations triggered by the DIP Switch.

2. Interfacing Protocol

The XStream-PKG-R RF Modem supports the following interfacing protocols:

- RS-232
- RS-485 (2-wire) Half-Duplex
- RS-485 (4-wire) and RS-422

2.1. RS-232 Operation

2.1.1. DIP Switch Settings and Pin Signals

Figure 2.1.
RS-232 DIP Switch Settings

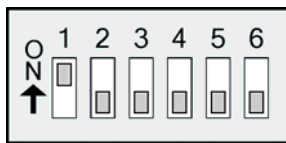

DIP Switch settings are read and applied only while powering-on.

Figure 2.2.
Pins used on the female RS-232 (DB-9) Serial Connector

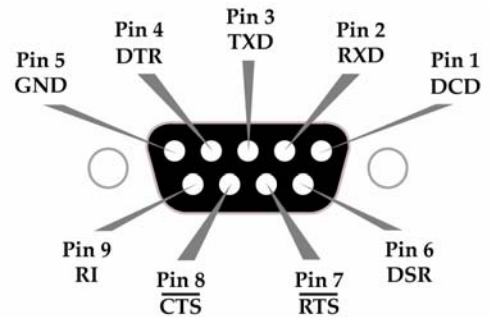

Table 2.1. RS-232 Signals and their implementations on the XStream RF Modem
(Low-asserted signals are distinguished by horizontal line over pin name.)

| DB-9 Pin | RS-232 Name | AT Command Reference* | Description | Implementation |
|----------|---------------------|-----------------------|---------------------|---|
| 1 | DCD | DO3 | Data-Carrier-Detect | Connected to DSR (pin6) |
| 2 | RXD | DO | Received Data | Serial data exiting the RF Modem (to host) |
| 3 | TXD | DI | Transmitted Data | Serial data entering into the RF modem (from host) |
| 4 | DTR | DI3 | Data-Terminal-Ready | Can enable POWER-DOWN on the RF Modem |
| 5 | GND | - | Ground Signal | Ground |
| 6 | DSR | DO3 | Data-Set-Ready | Connected to DCD (pin1) |
| 7 | <u>RTS</u> / CMD | DI2 | Request-to-Send | Provides <u>RTS</u> flow control or enables "Command Mode" on the RF Modem |
| 8 | <u>CTS</u> | DO2 | Clear-to-Send | Provides <u>CTS</u> flow control |
| 9 | RI | - | Ring Indicator | Optional power input that is connected internally to the positive lead of the front power connector |

* Inside the XStream RF Modem is an XStream OEM RF Module. The names in this column refer to the pin signals of the embedded RF module. XStream Commands [p24] used to configure pin behaviors are named according to the pins of the module, not the RS-232 connection pins.

Wiring Diagram: RS-232 DTE Device to a DCE RF Modem

Figure 2.3. RS-232 DTE (male connector) device wired to an XStream RF Modem (female connector)

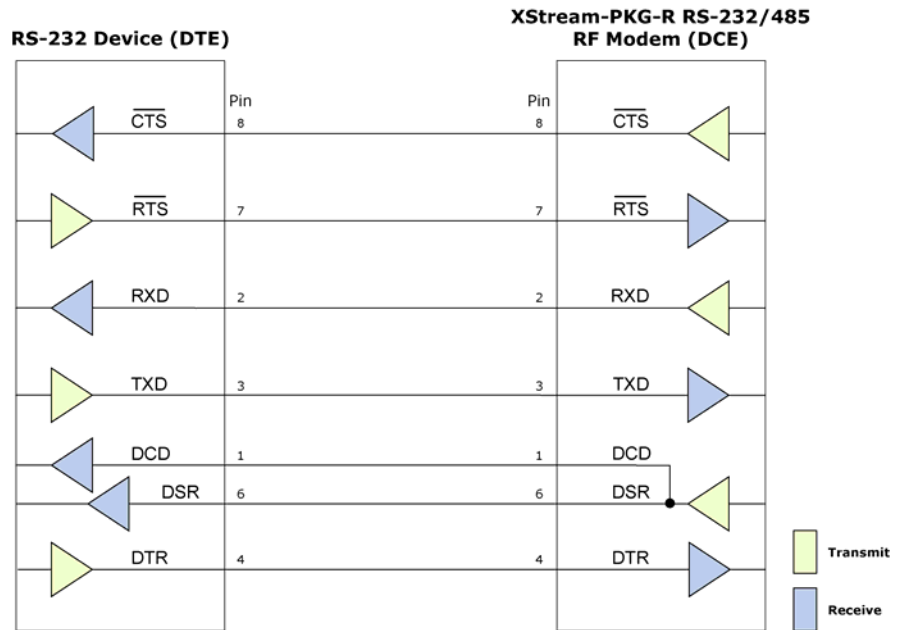

Wiring Diagram: DCE RF Modem to an RS-232 DCE Device

Figure 2.4. XStream RF Modem (female connector) wired to an RS-232 DTE (male connector) device

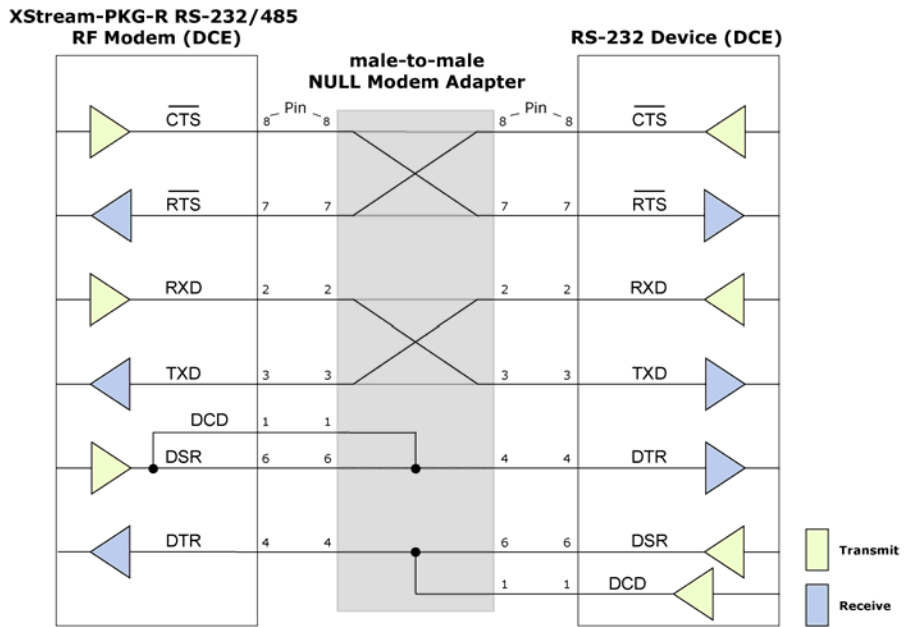

Sample Wireless Connection: DTE ↔ DCE ⚡ DCE ↔ DCE

Figure 2.5. Typical wireless link between DTE and DCE devices



2.2. RS-485 (2-wire) Operation

2.2.1. DIP Switch Settings and Pin Signals

Figure 2.6.
RS-485 (2-wire) Half-Duplex
DIP Switch Settings

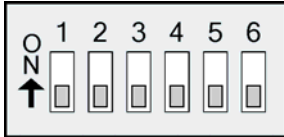
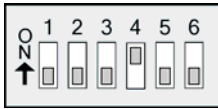

Figure 2.8.
RS-485 (2-wire) with Termination (optional)



Termination is the 120 Ω resistor between T+ and T-.

DIP Switch settings are read and applied only while powering-on.

Figure 2.7.
Pins used on the female RS-232 (DB-9)
Serial Connector

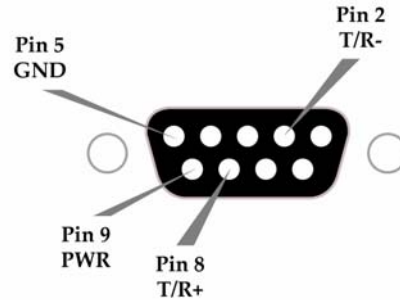

Note: Refer to Figures 2.15 & 2.16 for RJ-45 connector pin designations used in RS-485/422 environments.

Table 2.2. RS-485 (2-wire half-duplex) Signals and their implementations on the XStream RF Modem

| DB-9 Pin | RS-485 Name | Description | Implementation |
|---------------|-------------|--------------------|--|
| 2 | T/R- (TRA) | Negative Data Line | Transmit serial data to and from the XStream RF Modem |
| 5 | GND | Ground Signal | Ground |
| 8 | T/R+ (TRB) | Positive Data Line | Transmit serial data to and from the XStream RF Modem |
| 9 | PWR | Power | Optional power input that is connected internally to the front power connector |
| 1, 3, 4, 6, 7 | | | not used |

Wiring Diagram: RS-485 (2-wire) Half-Duplex

Figure 2.9. XStream RF Modem in an RS-485 (2-wire) half-duplex environment

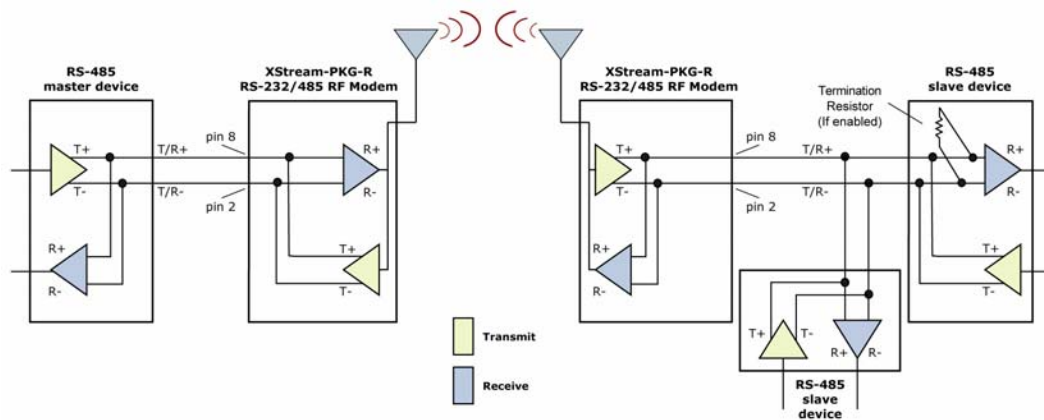

2.3. RS-485 (4-wire) & RS-422 Operation

2.3.1. DIP Switch Settings and Pin Signals

Figure 2.10.
RS-485 (4-wire) and RS-422
DIP Switch Settings

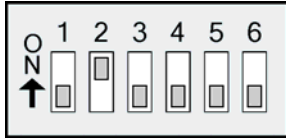

Figure 2.12.
RS-485 (4-wire) & RS-422 with Termination (optional)



Termination is the 120 Ω resistor between T+ and T-.

DIP Switch settings are read and applied only while powering-on.

Figure 2.11.
Pins used on the female RS-232 (DB-9)
Serial Connector

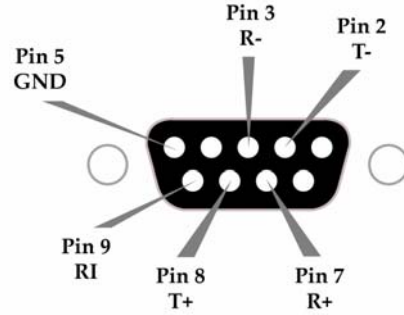
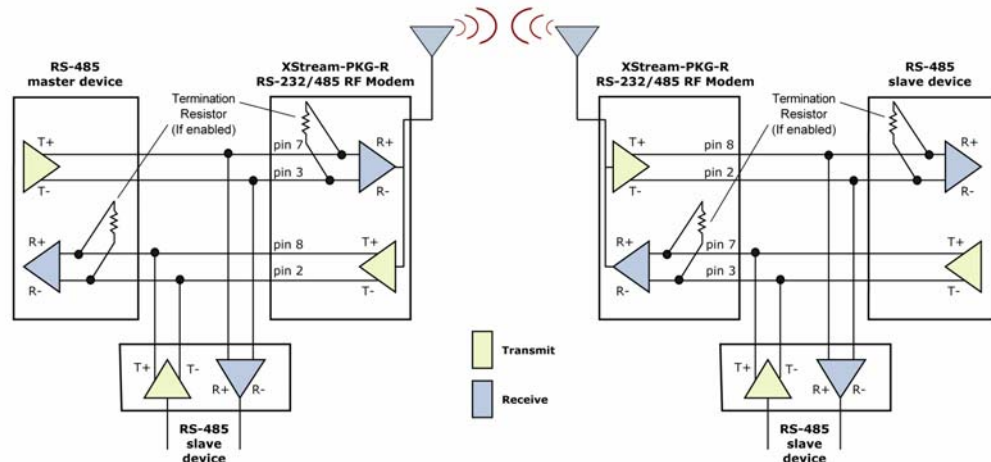

Table 2.3. RS-485/422 (4-wire) Signals and their implementations with the XStream-PKG-R RF Modem

| DB-9 Pin | RS-485/422 Name | Description | Implementation |
|----------|-----------------|-----------------------------|--|
| 2 | T- (TA) | Transmit Negative Data Line | Serial data sent from the XStream RF Modem |
| 3 | R- (RA) | Receive Negative Data Line | Serial data received by the XStream RF Modem |
| 5 | GND | Signal Ground | Ground |
| 7 | R+ (RB) | Receive Positive Data Line | Serial data received by the XStream RF Modem |
| 8 | T+ (TB) | Transmit Positive Data Line | Serial data sent from the XStream RF Modem |
| 9 | PWR | Power | Optional power input that is connected internally to the front power connector |
| 1, 4, 6 | | | not used |

Wiring Diagram: RS-485 (4-wire) Half-Duplex

Figure 2.13. XStream RF Modem in an RS-485 (4-wire) environment



Wiring Diagram: RS-422

Figure 2.14. XStream RF Modem in an RS-485 (4-wire) environment

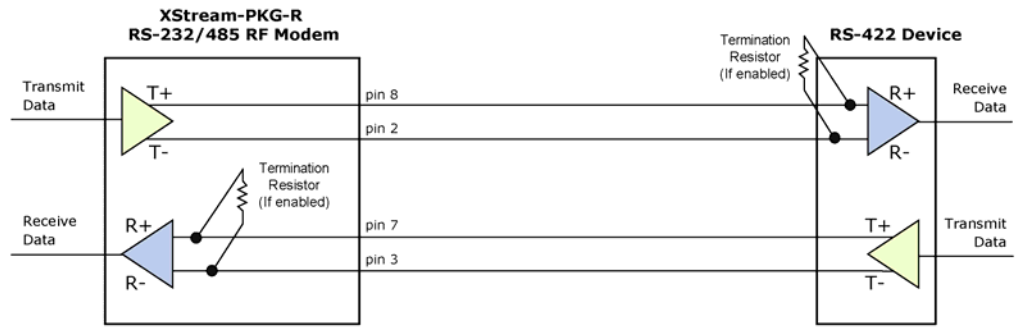

RS-485/422 Connection Guidelines

The RS-485/422 protocol provides a solution for wired communications that can tolerate high noise and push signals over long cable lengths. RS-485/422 signals can communicate as far as 4000 feet (1200 m). RS-232 signals are suitable for cable distances up to 100 feet (30.5 m).

RS-485 offers multi-drop capability in which up to 32 nodes can be connected. The RS-422 protocol is used for point-to-point communications.

Suggestions for integrating the XStream Modem with the RS-485/422 protocol:

1. When using Ethernet twisted pair cabling: Select wires so that T+ and T- are connected to each wire in a twisted pair. Likewise, select wires so that R+ and R- are connected to a twisted pair. (For example, tie the green and white/green wires to T+ and T-.)
2. For straight-through Ethernet cable (not cross-over cable) – The following wiring pattern works well: Pin3 to T+, Pin4 to R+, Pin5 to R-, Pin6 to T-
3. Note that the connecting cable only requires 4 wires (even though there are 8 wires).
4. When using phone cabling (RJ-11) – Pin2 in the cable maps to Pin3 on opposite end of cable and Pin1 maps to Pin4 respectively.

Figure 2.15. Male (yellow) DB-9 to RJ-45 Adapters

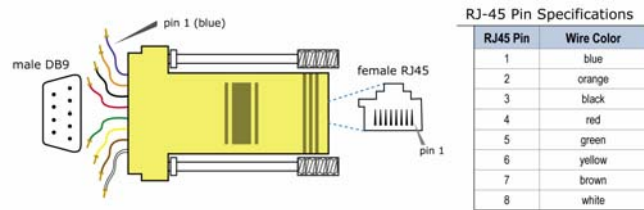
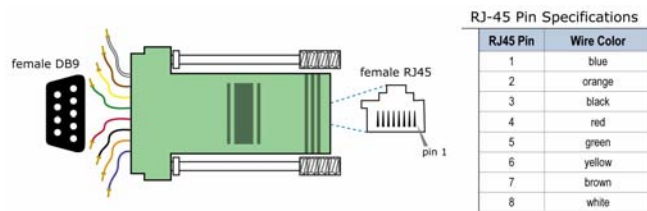

Figure 2.16. Female (green) DB-9 to RJ-45 Adapters



An RS-232 Accessories Kit is available that includes connectors that facilitate RS-232/485/422 and other serial communications. Refer to the Development Guide in Appendix B for information concerning the connectors and tools included in the kit.

3. RF Modem Operation

3.1. Serial Communications

3.1.1. RS-232 and RS-485/422 Data Flow

Devices that have a UART interface can connect directly through the pins of the XStream Modem as is shown in the figure below.

Figure 3.1. System Data Flow Diagram in a UART-interfaced environment

(Low-asserted signals distinguished with horizontal line over signal name.)

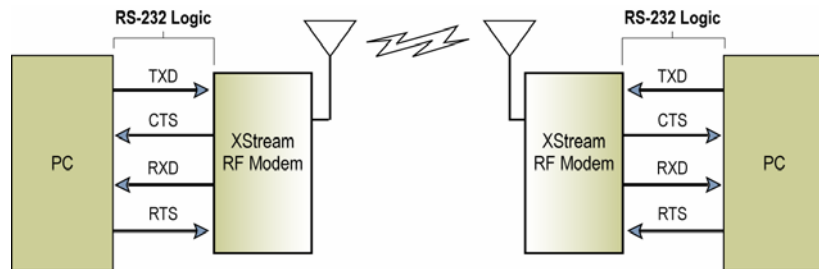

3.1.2. Host and RF Modem I/O Settings

Serial communications between a host and an XStream RF Modem are dependent upon having matching baud rate, parity, stop bit & number of data bits settings. Failure to enter the modem into AT Command Mode is most commonly due to baud rate mismatch. Refer to the table below to ensure host serial port settings match those of the modem.

Table 3.1. Parameter values critical to serial communications between the RF Modem and host

| Parameter Setting | XStream RF Modem Default Parameter Value |
|-------------------------|--|
| Baud (Serial Data Rate) | 9600 bps or 19200 baud (Factory-set RF data rates) |
| Number of Data Bits | 8 (NB parameter = 0) |
| Parity | None (NB parameter = 0) |
| Number of Stop Bits | 1 (NB parameter = 0) |

Both the XStream RF Modem and host (PC) settings can be viewed and adjusted using MaxStream’s proprietary X-CTU Software. Use the “PC Settings” tab to configure host settings. Use the “Terminal” or “Modem Configuration” tabs to configure the RF Modem settings. Refer to the RF Modem Configuration sections for more information [p21].

3.1.3. Flow Control

Figure 3.2. Internal Data Flow Diagram

(The five most commonly-used pin signals are shown.)

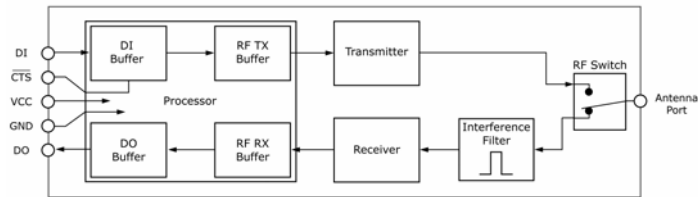

DI (Data In) Buffer and Flow Control

When serial data enters the XStream Modem through the DI Pin, then the data is stored in the DI Buffer until it can be transmitted.

When the RO parameter threshold is satisfied (refer to Transmit Mode [p14] and Command Descriptions [p25] sections for more information), the modem attempts to initialize an RF connection. If the modem is already receiving RF data, the serial data is stored in the modem's DI Buffer. If the DI buffer becomes full, hardware or software flow control must be implemented in order to prevent overflow (loss of data between the host and XStream RF Modem).

How to eliminate the need for flow control:

1. Send messages that are smaller than the DI buffer size. The size of the DI buffer varies according to the packet size and parity setting used.
2. Interface at a lower baud rate (BD Command) than the fixed RF data rate.

Two cases in which the DI Buffer may become full and possibly overflow:

1. If the serial interface data rate is set higher than the RF data rate of the modem, the modem will receive data from the host faster than it can transmit the data over-the-air.
2. If the modem is receiving a continuous stream of RF data or if the modem is monitoring data on a network, any serial data that arrives on the DI pin is placed in the DI Buffer. The data in the DI buffer will be transmitted over-the-air when the modem no longer detects RF data in the network.

Hardware Flow Control (CTS). When the DI buffer is 17 bytes away from being full; by default, the modem de-asserts (high) $\overline{\text{CTS}}$ to signal to the host device to stop sending data [refer to the FT (Flow Control Threshold) and CS (DO2 Configuration) commands]. $\overline{\text{CTS}}$ is re-asserted after the DI Buffer has 34 bytes of memory available.

Software Flow Control (XON). XON/XOFF software flow control can be enabled using the FL (Software Flow Control) Command. This option only works with ASCII data.

DO (Data Out) Buffer and Flow Control

When RF data is received, the data enters the DO buffer and is then sent out the serial port to a host device. Once the DO Buffer reaches capacity, any additional incoming RF data is lost.

Two cases in which the DO Buffer may become full and possibly overflow:

1. If the RF data rate is set higher than the interface data rate of the modem, the modem will receive data from the transmitting modem faster than it can send the data to the host.
2. If the host does not allow the modem to transmit data out from the DO buffer because of being held off by hardware or software flow control.

Hardware Flow Control (RTS). If $\overline{\text{RTS}}$ is enabled for flow control (RT Parameter = 2), data will not be sent out the DO Buffer as long as $\overline{\text{RTS}}$ is de-asserted.

Software Flow Control (XOFF). XON/XOFF software flow control can be enabled using the FL (Software Flow Control) Command. This option only works with ASCII data.

3.2. Modes of Operation

XStream RF Modems operate in five modes.

Figure 3.3. XStream Modes of Operation
Modem can only be in one mode at a time.

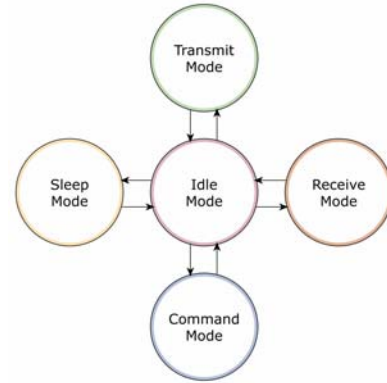

3.2.1. Idle Mode

When not receiving or transmitting data, the modem is in Idle Mode. The modem uses the same amount of power in Idle Mode as it does in Receive Mode.

The modem shifts into the other modes of operation under the following conditions:

- Serial data is received in the DI Buffer (Transmit Mode)
- Valid RF data is received through the antenna (Receive Mode)
- Command Mode Sequence is issued (Command Mode)
- Sleep Mode condition is met (Sleep Mode)

After responding to any of the preceding conditions, the modem automatically transitions back into Idle Mode.

3.2.2. Transmit Mode

When the first byte of serial data is received from the UART in the DI buffer, the modem attempts to shift to Transmit Mode and initiate an RF connection with other modems.

Figure 3.4. Transmission of Data →

Once in Transmit Mode, the modem initializes a communications channel. Channel initialization is the process of sending an RF initializer that synchronizes receiving modems with the transmitting modem. When streaming multiple RF packets, the RF Initializer is only sent in front of the first packet. During channel initialization, incoming serial data accumulates in the DI buffer.

After the channel is initialized, data in the DI buffer is grouped into packets (up to 64 bytes in each packet) and is transmitted. The modem continues to transmit data packets until the DI buffer is empty. Once transmission is finished, the modem returns to Idle Mode. This progression is shown in Figure 3.4.

As the transmitting modem nears the end of the transmission, it inspects the DI buffer to see if more data exists to be transmitted. This could be the case if more bytes arrived from the host after the transmission began. If more data is pending, the transmitting modem assembles a subsequent packet for transmission.

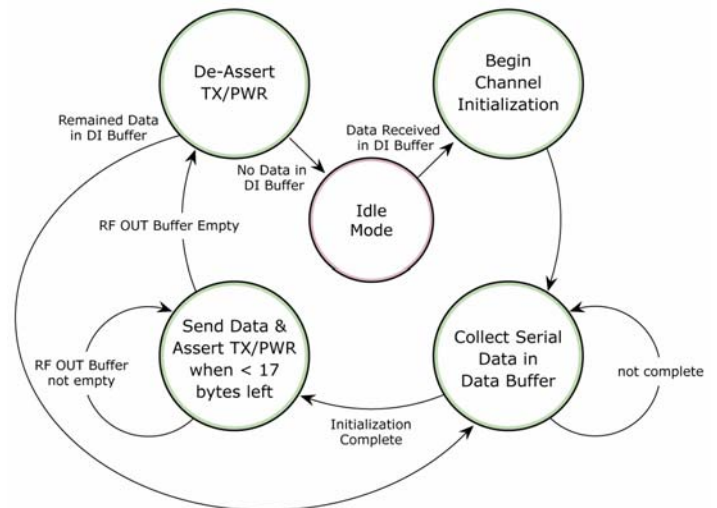

RF Packet

The RF packet is the sequence of data used for communicating information between MaxStream Modems. An RF Packet consists of an RF Initializer and RF Data.

Figure 3.5. RF Packet Components

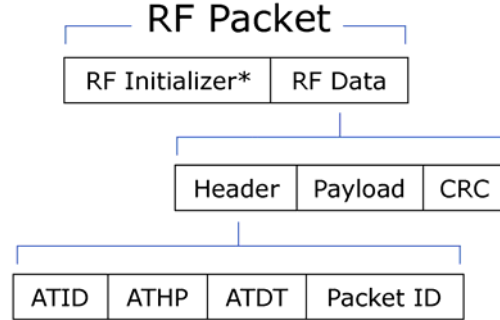

* When streaming multiple RF packets, the RF Initializer is only sent in front of the first packet.

RF Initializer

An RF initializer is sent each time a new connection sequence begins. The RF initializer contains channel information that notifies receiving modems of information such as the hopping pattern used by the transmitting modem. The first transmission always sends an RF initializer.

An RF initializer can be of various lengths depending on the amount of time determined to be required to prepare a receiving modem. For example, a wake-up initializer is a type of RF initializer used to wake remote modems from Sleep Mode (Refer to the FH, LH, HT and SM Commands for more information). The length of the wake-up initializer should be longer than the length of time remote modems are in cyclic sleep.

Header

The header contains network addressing information that is used to filter incoming RF data. The receiving modem checks for matching a VID, Hopping Channel and Destination Address. Data that does not pass through all three network filter layers is discarded.

Figure 3.6. Filtration Layers Contained in the Header

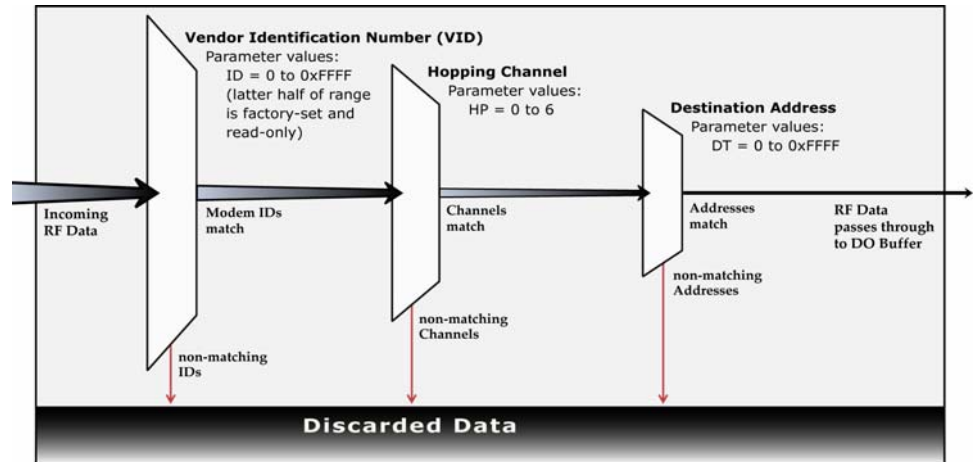

CRC (Cyclic Redundancy Check)

To verify data integrity and provide built-in error checking, a 16-bit CRC (Cyclic Redundancy Check) is computed for the transmitted data and attached to the end of each RF packet. On the receiving end, the receiving modem computes the CRC on all incoming RF data. Received data that has an invalid CRC is discarded [Refer to the Receive Mode section, next page].

3.2.3. Receive Mode

If a modem detects RF data while operating in Idle Mode, the modem transitions into Receive Mode to start receiving RF packets.

Figure 3.7. Reception of RF Data →

After a packet is received, the modem checks the CRC (cyclic redundancy check) to ensure that the data was transmitted without error. If the CRC data bits on the incoming packet are invalid, the packet is discarded. If the CRC is valid, the packet proceeds to the DO Buffer.

The modem returns to Idle Mode after valid RF data is no longer detected or after an error is detected in the received RF data. If serial data is stored in the DI buffer while the modem is in Receive Mode, the serial data will be transmitted after the modem is finished receiving data and returns to Idle Mode.

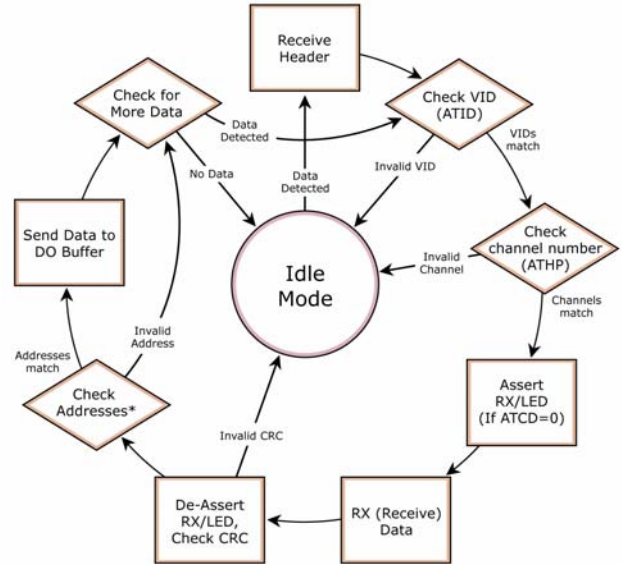

3.2.4. Sleep Modes

Sleep Modes enable the XStream Modem to operate at minimal power consumption when not in use. Three Sleep Mode options are available:

- **Pin Sleep** (Host Controlled)
- **Serial Port Sleep** (Wake on Serial Port activity)
- **Cyclic Sleep** (Wake on RF activity)

For the modem to transition into Sleep Mode, the modem must have a non-zero SM (Sleep Mode) Parameter and one of the following must occur:

1. The modem is idle (no data transmission or reception) for a user-defined period of time [Refer to the ST (Time before Sleep) Command].
2. SLEEP pin is asserted (only for Pin Sleep option).

In Sleep Mode, the modem will not transmit or receive data until the modem first transitions to Idle Mode. All Sleep Modes are enabled and disabled using SM Command. Transitions into and out of Sleep Modes are triggered by various mechanisms as shown in the table below.

Table 3.2. Summary of Sleep Mode Configurations

| Sleep Mode Setting | Transition into Sleep Mode | Transition out of Sleep Mode | Related Commands | Typical Power Consumption |
|----------------------------|--|--|--------------------|---------------------------|
| Pin Sleep (SM = 1) | A microcontroller can shut down and wake modems by asserting (high) SLEEP pin. Note: The module will complete a transmission or reception before activating Pin Sleep. | De-assert SLEEP pin. | SM | 6 mA |
| Serial Port Sleep (SM = 2) | Automatic transition to Sleep Mode occurs after a user-defined period of inactivity (no transmitting or receiving of data). The period of activity is defined using the ST (Time before Sleep) Command. | When serial byte is received on the DI pin. | SM, ST | 25 mA |
| Cyclic Sleep (SM = 3-8) | Automatic transition to Sleep Mode occurs in cycles as defined by the SM (Sleep Mode) Command. Note: The cyclic sleep time interval must be shorter than the "Wake-up Initializer Timer" (set by LH Command). | After the cyclic sleep time interval elapses. Note: Modem can be forced into Idle Mode if PW (Pin Wake-up) Command is issued. | SM, ST, HT, LH, PW | 6 mA when sleeping |

For more information about Sleep Modes, refer to the individual commands listed in "Related Commands" column of the table. SM Command is the best starting point for implementing sleep mode configurations.

Pin Sleep (SM = 1)

Pin Sleep requires the least amount of power. In order to achieve this state, DI3 (SLEEP) pin must be asserted (high). The modem remains in Pin Sleep until the DI3 pin is de-asserted.

After enabling Pin Sleep, the SLEEP pin controls whether the XStream Modem is active or in Sleep Mode. When DI3 is de-asserted (low), the modem is fully operational. When DI3 is asserted (high), the modem transitions to Sleep Mode and remains in its lowest power-consuming state until the DI3 (SLEEP) pin is de-asserted. DI3 is only active if the modem is setup to operate in this mode; otherwise the pin is ignored.

Once in Pin Sleep Mode, DO2 ($\overline{\text{CTS}}$) is de-asserted (high), indicating that data should not be sent to the modem. The PWR pin is also de-asserted (low) when the modem is in Pin Sleep Mode.

Note: The module will complete a transmission or reception before activating Pin Sleep.

Serial Port Sleep (SM = 2)

Serial Port Sleep is a Sleep Mode in which the XStream Modem runs in a low power state until serial data is detected on the DI pin.

When Serial Port Sleep is enabled, the modem goes into Sleep Mode after a user-defined period of inactivity (no transmitting or receiving of data). This period of time is determined by ST (Time before Sleep) Command. Once a character is received through the DI pin, the modem returns to Idle Mode and is fully operational.

Cyclic Sleep (SM = 3-8)

Cyclic Sleep is the Sleep Mode in which the XStream Modem enters into a low-power state and awakens periodically to determine if any transmissions are being sent.

When Cyclic Sleep settings are enabled, the XStream Modem goes into Sleep Mode after a user-defined period of inactivity (no transmission or reception on the RF channel). The user-defined period is determined by ST (Time before Sleep) Command.

While the modem is in Cyclic Sleep Mode, DO2 ($\overline{\text{CTS}}$) is de-asserted (high) to indicate that data should not be sent to the modem during this time. When the modem awakens to listen for data, DO2 is asserted and any data received on the DI Pin is transmitted. The PWR pin is also de-asserted (low) when the modem is in Cyclic Sleep Mode.

The modem remains in Sleep Mode for a user-defined period of time ranging from 0.5 seconds to 16 seconds (SM Parameters 3 through 8). After this interval of time, the modem returns to Idle Mode and listens for a valid data packet for 100 ms. If the modem does not detect valid data (on any frequency), the modem returns to Sleep Mode. If valid data is detected, the modem transitions into Receive Mode and receives incoming RF packets. The modem then returns to Sleep Mode after a Period of inactivity that is determined by ST "Time before Sleep" Command.

The modem can also be configured to wake from cyclic sleep when SLEEP/DI3 is de-asserted (low). To configure a modem to operate in this manner, PW (Pin Wake-up) Command must be issued. Once DI3 is de-asserted, the modem is forced into Idle Mode and can begin transmitting or receiving data. It remains active until no data is detected for the period of time specified by the ST Command, at which point it resumes its low-power cyclic state.

Note: The cyclic interval time defined by SM (Sleep Mode) Command must be shorter than the interval time defined by LH (Wake-up Initializer Timer).

For example: If SM=4 (Cyclic 1.0 second sleep), the LH Parameter should equal 0x0B ("1.1" seconds). With these parameters set, there is no risk of the receiving modem being asleep for the duration of wake-up initializer transmission. "Cyclic Scanning" explains in further detail the relationship between "Cyclic Sleep" and "Wake-up Initializer Timer"

Cyclic Scanning. Each RF transmission consists of an RF Initializer and payload. The wake-up initializer contains initialization information and all receiving modems must wake during the wake-up initializer portion of data transmission in order to be synchronized with the transmitting modem and receive the data.

Figure 3.8. Correct Configuration (LH > SM)

Length of the wake-up initializer exceeds the time interval of Cyclic Sleep. The receiver is guaranteed to detect the wake-up initializer and receive the accompanying payload data.

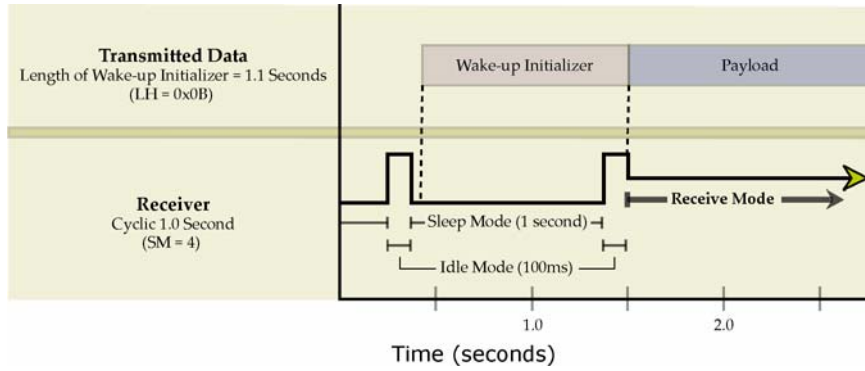
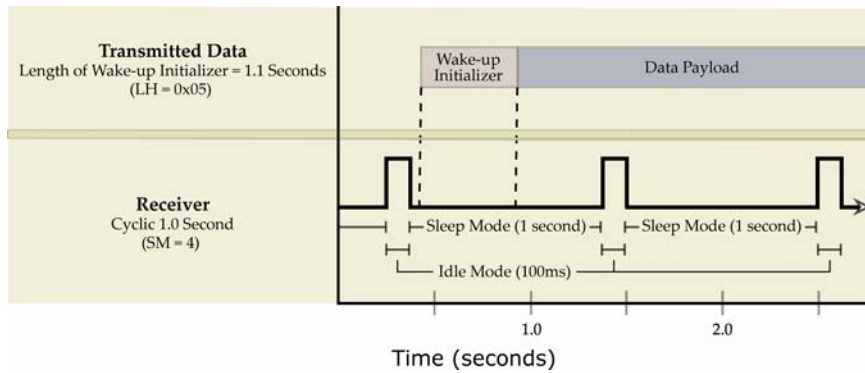

Figure 3.9. Incorrect Configuration (LH < SM)

Length of wake-up initializer is shorter than the time interval of Cyclic Sleep. This configuration is vulnerable to the receiver waking and missing the wake-up initializer (and therefore also the accompanying payload data).



3.2.5. Command Mode

To modify or read modem parameters, the modem must first enter into Command Mode, the state in which incoming characters are interpreted as commands. Two command types are available for programming the modem:

- AT Commands
- Binary Commands

For modified parameter values to persist in the modem registry, changes must be saved to non-volatile memory using WR (Write) Command. Otherwise, parameters are restored to previously saved values when the modem is powered off and then on again.

AT Commands

To Enter AT Command Mode:

1. Send the 3-character command sequence “+++” and observe guard times before and after the command characters. [Refer to the “Default AT Command Mode Sequence” below.] The “Terminal” tab (or other serial communications software) of the X-CTU Software can be used to enter the sequence.
[OR]
2. Assert (low) the `CONFIG` pin and turn the power going to the modem off and back on. This result can be achieved by keeping the configuration switch pressed while turning off, then on again the power supplying the RF Modem)

Default AT Command Mode Sequence (for transition to Command Mode):

- No characters sent for one second [refer to the BT (Guard Time Before) Command]
- Input three plus characters (“+++”) within one second [refer to the CC (Command Sequence Character) Command.]
- No characters sent for one second [refer to the AT (Guard Time After) Command.]

To Send AT Commands:

Send AT commands and parameters using the syntax shown below:

Figure 3.10. Syntax for sending AT Commands

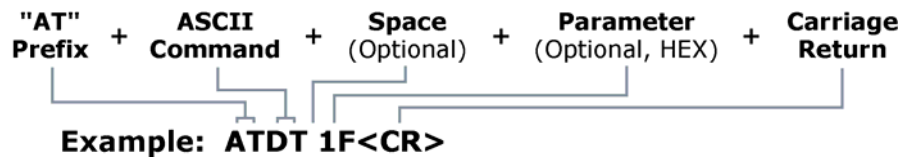

NOTE: To read a parameter value stored in a register, leave the parameter field blank.

The preceding example would change the modem Destination Address to “1F”. To store the new value to non-volatile (long term) memory, the Write (ATWR) Command must follow.

System Response. When a command is sent to the modem, the modem will parse and execute the command. Upon successful execution of a command, the modem returns an “OK” message. If execution of a command results in an error, the modem returns an “ERROR” message.

To Exit AT Command Mode:

1. Send ATCN (Exit Command Mode) Command.
[OR]
2. If no valid AT Commands are received within the time specified by CT (Command Mode Timeout) Command, the Modem automatically returns to Idle Mode.

For examples that illustrate the steps of programming the modem using AT Commands, refer to the RF Modem Configuration [p21] chapter.

Binary Commands

Sending and receiving parameter values using binary commands is the fastest way to change operating parameters of the XStream RF Modem. Binary commands are used most often to sample signal strength (RS parameter) and/or error counts; or change modem addresses and channels for polling data systems. Since the sending and receiving of register values takes place through the same serial data path as 'live' data (received RF payload), interference between the two types of data can be a concern.

Common questions about using binary commands:

- What are the implications of asserting CMD while live data is being sent or received?
- After sending serial data, is there a minimum time delay before CMD can be asserted?
- Is a delay required after CMD is de-asserted before payload data can be sent?
- How does one discern between live data and data received in response to a command?

The CMD pin must be asserted in order to send binary commands to the RF modem. The CMD pin can be asserted to recognize binary commands anytime during the transmission or reception of data. The status of the CMD signal is only checked at the end of the stop bit as the byte is shifted into the serial port. The application does not allow control over when data is received, except by waiting for dead time between bursts of communication.

If the command is sent in the middle of a stream of payload data to be transmitted, the command will essentially be executed in the order it is received. If the radio is continuously receiving data, the radio will wait for a break in the received data before executing the command. The CTS signal will frame the response coming from the binary command request [Figure 3.11].

A minimum time delay of 100 μs (after the stop bit of the command byte has been sent) must be observed before the CMD pin can be de-asserted. The command executes after all parameters associated with the command have been sent. If all parameters are not received within 0.5 seconds, the modem returns to Idle Mode.

Note: When parameters are sent, they are two bytes long with the least significant byte sent first. Binary commands that return one parameter byte must be written with two parameter bytes.

Refer to p23 for a binary programming example.

Commands can be queried for their current value by sending the command logically ORed (bit-wise) with the value 0x80 (hexadecimal) with CMD asserted. When the binary value is sent (with no parameters), the current value of the command parameter is sent back through the DO pin.

Figure 3.11. Binary Command Write then Read

Signal #4 is CMD
 Signal #1 is the DIN signal to the radio
 Signal #2 is the DOUT signal from the radio
 Signal #3 is CTS

In this graph, a value was written to a register and then read out to verify it. While not in the middle of other received data, note that the CTS (DO2 pin) signal outlines the data response out of the modem.

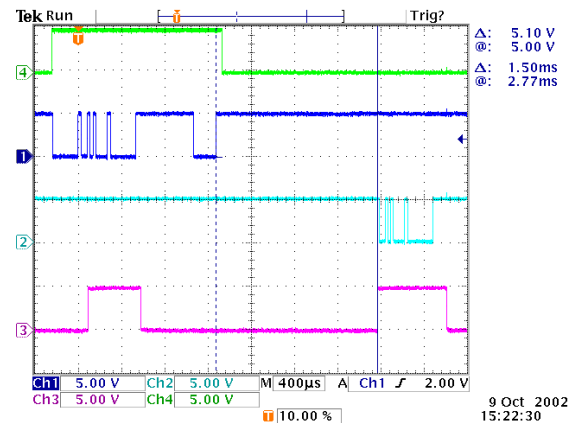

9 Oct 2002
 15:22:30

IMPORTANT: For the XStream Modem to recognize a binary command, the RT (DI2 Configuration) parameter must be set to one. If binary programming is not enabled (RT ≠ 1), the modem will not recognize that the CMD pin is asserted and therefore will not recognize the data as binary commands.

4. RF Modem Configuration

4.1. Automatic DIP Switch Configurations

Each time the RF Modem is powered-on, intelligence on the XIB-R Interface Board (RS-232/485 interfacing board located inside the RF Modem) sends AT Commands that program the RF Modem based on positions of the DIP Switch. Automatic configurations that take place during the power-on sequence affect stored RF Modem parameter values as shown in the tables below.

Figure 4.1. RF Modem DIP Switch

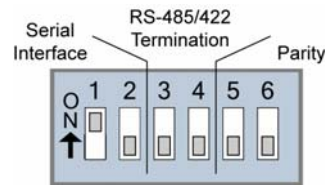

Table 4.1. RF Modem Power-up Options (J7 jumper and Config Switch)

| Condition | Behavior |
|---|--|
| If J7 is populated | Processor is disabled and AT Commands are not sent to the RF Modem |
| If Config Switch is pressed | Processor is disabled and RF Modem enters into AT Command Mode |
| If J7 is NOT populated and Config Switch is NOT pressed | Execute logic as shown in table below. |

Table 4.2. AT Commands Sent as result of DIP Switch Settings (SW = DIP Switch)

| Condition | Behavior |
|--|---|
| Restore Default Parameter Values of the RF Modem | |
| If SW1 & SW2 are ON (up) | AT Commands sent: ATRE (Restore Defaults) Command ATWR (Write) Command |
| Serial Interfacing Options | |
| If SW1 is ON (up) | AT Commands sent: ATCS 0 (RS-232 Operation: CTS function for CTS line, DB-9 pin 8) ATCD 2 (DO3 - RX LED = low) |
| If SW1 is OFF (down) | AT Commands sent: ATCS 3 (RS-485 or RS-422 Operation) ATCD 2 (DO3 - RX LED = low) |
| Parity Options | |
| If SW5 & SW6 are OFF (down) | AT Commands sent: ATNB 0 (parity = none) |
| If SW5 is OFF (down) & SW6 is ON (up) | AT Commands sent: ATNB 1 (parity = even) |
| If SW5 is ON (up) & SW6 is OFF (down) | AT Commands sent: ATNB 2 (parity = odd) |
| If SW5 is ON (up) & SW6 is ON (up) | AT Commands sent: ATNB 5 (parity = 9th bit data over-the-air, v4.30 only) |
| Exit AT Command Mode | |
| Always | AT Commands sent: ATCN (Exit AT Command Mode) |

IMPORTANT: To avoid overwriting previously stored custom configurations (due to the automatic configurations that take place each time the RF Modem is powered-on), it is necessary to disable a processor located on the XIB-R interface board. To disable the processor, populate the J7 jumper of the XIB-R Interface Board. By default, J7 is not populated.

4.2. Programming the Modem

For information about entering and exiting AT and Binary Command Modes, refer to the Command Mode section [p19].

4.2.1. AT Command Examples

MaxStream has provided X-CTU software for programming the modem using an extensive list of AT Commands. The X-CTU software provides an interface that is divided into four tabs that facilitate the following functions:

- PC Settings tab - Setup PC serial port to interface with an XStream RF Modem
- Range Test tab - Test XStream RF Modem's range in varying environments
- Terminal tab - Configure and read XStream RF Modem parameters using AT Commands
- Modem Configuration tab - Configure and read RF Modem parameters

To install the X-CTU Software:

Double-click the "setup_X-CTU.exe" file located in the MaxStream CD or under the "Downloads" section of the following web page: www.maxstream.net/support/downloads.php. Then follow the prompts of the installation screens.

PC Settings Tab

As stated in the Serial Communications section; in order to communicate data to the RF modem through the PC, baud (serial data rate), data bit, parity and stop bit settings on the PC serial port must match those of the RF modem. The PC Settings tab provides a software user interface that facilitates the modification of PC serial port settings.

PC Setup

1. Set the DIP Switch to RS-232 mode. Switch 1 is ON (up) and the remaining 5 switches are OFF (down).
2. Connect the male DB-9 connector of the PC with the female DB-9 connector of the RF modem using an RS-232 cable.
3. Power the RF modem through the power connector.
4. Launch X-CTU Software and select the PC Settings tab; then select parameter values from the dropdown lists that match the current parameter values of the RF modem. [Refer to Table 3.1 on for more information.]

Figure 4.2. RF Modem Configurations through a Serial Cable

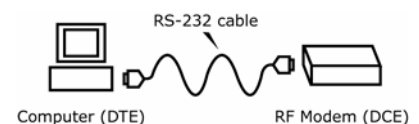

Terminal Tab

A terminal program has been built into the X-CTU software and is located under the Terminal tab. The Terminal tab provides an easy-to-use interface for programming the modem.

Multiple AT Commands. Multiple AT commands can be entered on one line with one carriage return at the end of the line. Each command must be delimited by a comma (spaces in between are optional). The "AT" prefix is only sent before the first command and should not be included with subsequent commands in a line.

System Response. When a command is sent to the modem, the modem will parse and execute the command. Upon successful execution of a command, the modem returns an "OK" message. If execution of a command results in an error, the modem returns an "ERROR" message.

EXAMPLE: Restore RF Modem Defaults using the Terminal tab

The following steps show how to read currently stored modem parameter values; then restore the modem parameters to their factory-default states.

Method 1 (One line per command)

| Issue AT Command | System Response |
|------------------|--|
| +++ | OK<CR> (Enter into AT Command Mode) |
| ATHP <Enter> | (system shows current channel number) <CR> |
| ATRE <Enter> | OK<CR> (Restore modem default parameter values) |
| ATWR <Enter> | OK<CR> (Write new values to non-volatile memory) |
| ATCN <Enter> | OK<CR> (Exit AT Command Mode) |

Method 2 (Multiple commands on one line)

| Issue AT Command | System Response |
|----------------------|-----------------|
| +++ | OK<CR> |
| ATRE, WR, CN <Enter> | OK<CR> |

NOTE: Default parameter values of the RF modem can also be restored by selecting the "Restore Defaults" button located on the Modem Configuration tab [refer to the instructions below].

Modem Configuration tab

The "Modem Configuration" tab of the X-CTU software provides an easy-to-use interface for reading and setting RF modem parameters.

EXAMPLE: Read Parameters & Restore Defaults using the Modem Configuration tab

The following steps show how to read currently stored modem parameter values; then restore the modem parameters to their factory-default states.

1. Open the X-CTU program (Start --> Programs --> MaxStream --> X-CTU):
2. Under the "PC Settings" tab, select the PC Serial Com Port from the dropdown list that will be used to connect to the RF Modem.
3. Select a "Baud rate" to match the default RF data rate of the RF Modem. Use default values for all other fields.
4. Select the "Modem Configuration" tab.
5. Select the "Read" button to read currently stored parameter values of the modem.
6. Select the "Restore" button to restore factory-default parameter values.
7. Select the "Write" button to save default values to non-volatile (long-term) memory.

4.2.2. Binary Command Example

Example: Send Binary Commands

Example: Use binary commands to change the XStream Modem's destination address to 0x1A0D and save the new address to non-volatile memory.

1. RT Command must be set to "1" in AT Command Mode to enable binary programming.
2. Assert CMD (Pin is driven high). (Enter Binary Command Mode)
3. Send Bytes [Parameter bytes must be 2 bytes long]:

| | |
|----|---|
| 00 | (Send DT (Destination Address) Command) |
| 0D | (Least significant byte of parameter bytes) |
| 1A | (Most significant byte of parameter bytes) |
| 08 | (Send WR (Write) Command) |
4. De-assert CMD (Pin is driven low). (Exit Binary Command Mode)

Note: \overline{CTS} is high when command is being executed. Hardware flow control must be disabled as \overline{CTS} will hold off parameter bytes.

4.3. Command Reference Table

Table 4.1 XStream Commands

(The XStream RF Modem expects numerical values in hexadecimal. “d” denotes decimal equivalent.)

| AT Command | Binary Command | AT Command Name | Range | Command Category | # Bytes Returned | Factory Default |
|-------------|----------------|---------------------------------|--|----------------------|------------------|---------------------------------------|
| AT | 0x05 (5d) | Guard Time After | 0x02 – 0xFFFF [x 100 msec] | Command Mode Options | 2 | 0x0A (10d) |
| BD v4.2B* | 0x15 (21d) | Interface Data Rate | Standard baud rates: 0 – 6 Non-standard baud rates: 0x7D – 0xFFFF | Serial Interfacing | 2 | Set to equal factory-set RF data rate |
| BT | 0x04 (4d) | Guard Time Before | 2 – 0xFFFF [x 100 msec] | Command Mode Options | 2 | 0x0A (10d) |
| CC | 0x13 (19d) | Command Sequence Character | 0x20 – 0x7F | Command Mode Options | 1 | 0x2B (“+”) |
| CD v 4.2B* | 0x28 (40d) | DO3 Configuration | 0 - 4 | Serial Interfacing | 1 | 0 |
| CN | 0x09 (9d) | Exit AT Command Mode | - | Command Mode Options | - | - |
| CS v 4.27D* | 0x1F (31d) | DO2 Configuration | 0 – 4 | Serial Interfacing | 1 | 0 |
| CT | 0x06 (6d) | Command Mode Timeout | 0x02 – 0xFFFF [x 100 msec] | Command Mode Options | 2 | 0xC8 (200d) |
| DT | 0x00 (0d) | Destination Address | 0 – 0xFFFF | Networking | 2 | 0 |
| E0 | 0x0A (10d) | Echo Off | - | Command Mode Options | - | - |
| E1 | 0x0B (11d) | Echo On | - | Command Mode Options | - | - |
| ER | 0x0F (15d) | Receive Error Count | 0 – 0xFFFF | Diagnostics | 2 | 0 |
| FH | 0x0D (13d) | Force Wake-up Initializer | - | Sleep (Low Power) | - | - |
| FL | 0x07 (7d) | Software Flow Control | 0 – 1 | Serial Interfacing | 1 | 0 |
| FT v 4.27B* | 0x24 (36d) | Flow Control Threshold | 0 – 0xFF [bytes] | Serial Interfacing | 2 | varies |
| GD | 0x10 (16d) | Receive Good Count | 0 – 0xFFFF | Diagnostics | 2 | 0 |
| HP | 0x11 (17d) | Hopping Channel | 0 – 6 | Networking | 1 | 0 |
| HT | 0x03 (3d) | Time before Wake-up Initializer | 0 – 0xFFFF [x 100 msec] | Sleep (Low Power) | 2 | 0xFFFF |
| ID v 4.2B* | 0x27 (39d) | Modem VID | User settable: 0x10 - 0x7FFF Read-only: 0x8000 – 0xFFFF | Networking | 2 | - |
| LH | 0x0C (12d) | Wake-up Initializer Timer | 0 – 0xFF [x 100 msec] | Sleep (Low Power) | 1 | 1 |
| MK | 0x12 (18d) | Address Mask | 0 – 0xFFFF | Networking | 2 | 0xFFFF |
| NB v 4.27B* | 0x23 (35d) | Parity | 0 – 4 | Serial Interfacing | 1 | 0 |
| PC v 4.22* | 0x1E (30d) | Power-up Mode | 0 – 1 | Command Mode Options | 1 | 0 |
| PW v 4.22* | 0x1D (29d) | Pin Wake-up | 0 – 1 | Sleep (Low Power) | 1 | 0 |
| RE | 0x0E (14d) | Restore Defaults | - | (Special) | - | - |
| RN v 4.22* | 0x19 (25d) | Delay Slots | 0 – 0xFF [slots] | Networking | 1 | 0 |
| RO v 4.2AA* | 0x21 (33d) | Packetization Timeout | 0 – 0xFFFF [x 200 µsec] | Serial Interfacing | 2 | 0 |
| RP v 4.2AA* | 0x22 (34d) | RSSI PWM Timer | 0 - 0x7F [x 100 msec] | Diagnostics | 1 | 0 |
| RR v 4.22* | 0x18 (24d) | Retries | 0 – 0xFF | Networking | 1 | 0 |
| RS v 4.22* | 0x1C (28d) | RSSI | 0x06 – 0x36 [Read-only] | Diagnostics | 1 | - |
| RT | 0x16 (22d) | DI2 Configuration | 0 - 2 | Serial Interfacing | 1 | 0 |
| SB v 4.2B* | 0x36 (54d) | Stop Bits | 0 – 1 | Serial Interfacing | 1 | 0 |
| SH v 4.27C* | 0x25 (37d) | Serial Number High | 0 – 0xFFFF [Read-only] | Diagnostics | 2 | - |
| SL v 4.27C* | 0x26 (38d) | Serial Number Low | 0 – 0xFFFF [Read-only] | Diagnostics | 2 | - |
| SM | 0x01 (1d) | Sleep Mode | 0 – 8 | Sleep (Low Power) | 1 | 0 |
| ST | 0x02 (2d) | Time before Sleep | 0x10 – 0xFFFF [x 100 msec] | Sleep (Low Power) | 2 | 0x64 (100d) |
| SY | 0x17 (23d) | Time before Initialization | 0 – 0xFF [x 100 msec] | Networking | 1 | 0 (disabled) |
| TR v 4.22* | 0x1B (27d) | Transmit Error Count | 0 – 0xFFFF | Diagnostics | 2 | 0 |
| TT v 4.22* | 0x1A (26d) | Streaming Limit | 0 – 0xFFFF [0 = disabled] | Networking | 2 | 0xFFFF |
| VR | 0x14 (20d) | Firmware Version | 0 x 0xFFFF [Read-only] | Diagnostics | 2 | - |
| WR | 0x08 (8d) | Write | - | (Special) | - | - |

* Firmware version in which command and parameter options were first supported.

NOTE: AT Commands issued without a parameter value will return the currently stored parameter.

4.4. Command Descriptions

Commands in this section are listed alphabetically. Command categories are designated between the "< >" symbols that follow each command title. XStream Modems expect numerical values in hexadecimal and those values are designated by a "0x" prefix.

AT (Guard Time After) Command

<Command Mode Options> AT Command is used to set the time-of-silence that follows the command sequence character (CC Command). By default, AT Command Mode will activate after one second of silence.

Refer to the AT Commands section [p19] to view the default AT Command Mode sequence.

AT Command: ATAT

Binary Command: 0x05 (5 decimal)

Parameter Range: 0x02 – 0xFFFF
[x 100 milliseconds]

Number of bytes returned: 2

Default Parameter Value: 0x0A (10 decimal)

Related Commands: BT (Guard Time Before), CC (Command Sequence Character)

BD (Interface Data Rate) Command

<Serial Interfacing> BD Command allows the user to adjust the interface data rate and thus modify the rate at which serial data is sent to the modem. The new baud rate does not take effect until the CN (Exit AT Command Mode) Command is issued. The RF data rate is not affected by the BD Command.

Although most applications will only require one of the seven standard baud rates, non-standard baud rates are also supported.

Note: If the serial data rate is set to exceed the fixed RF data rate of the XStream modem, CTS flow control may need to be implemented as described in the Pin Signals and Flow Control sections of this manual.

Non-standard Interface Data Rates: When parameter values outside the range of standard baud rates are sent, the closest interface data rate represented by the number is stored in the BD register. For example, a rate of 19200 bps can be set by sending the following command line "ATBD4B00". NOTE: When using MaxStream's X-CTU Software, non-standard interface data rates can only be set and read using the X-CTU 'Terminal' tab. Non-standard rates are not accessible through the 'Modem Configuration' tab.

When the BD command is sent with a non-standard interface data rate, the UART will adjust to accommodate the requested interface rate. In most cases, the clock resolution will cause the stored BD parameter to vary from the parameter that was sent (refer to the table below). Reading the BD command (send "ATBD" command without an associated parameter value) will return the value that was actually stored to the BD register.

Table 4-01. Parameter Sent vs. Parameter Stored

| BD Parameter Sent (HEX) | Interface Data Rate (bps) | BD Parameter Stored (HEX) |
|-------------------------|---------------------------|---------------------------|
| 0 | 1200 | 0 |
| 4 | 19,200 | 4 |
| 7 | 115,200 | 7 |
| 12C | 300 | 12B |
| 1C200 | 115,200 | 1B207 |

AT Command: ATBD

Binary Command: 0x15 (21 decimal)

Parameter Range (Standard baud rates): 0 – 6
(Non-standard baud rates): 0x7D – 0xFFFF

| Parameter Value | BAUD (bps) Configuration |
|-----------------|--------------------------|
| 0 | 1200 |
| 1 | 2400 |
| 2 | 4800 |
| 3 | 9600 |
| 4 | 19200 |
| 5 | 38400 |
| 6 | 57600 |

Number of bytes returned: 2

Default Parameter Value: Set to equal to modem's factory-set RF data rate.

Minimum firmware version required: 4.2B
(non-standard baud rates not previously supported)

BT (Guard Time Before) Command

<Command Mode Options> BT Command is used to set the DI pin silence time that must precede the command sequence character (CC Command) of the AT Command Mode Sequence.

Refer to the AT Commands section [p19] to view the default AT Command Mode sequence.

AT Command: ATBT
 Binary Command: 0x04 (4 decimal)
 Parameter Range: 2 – 0xFFFF
 [x 100 milliseconds]
 Default Parameter Value: 0x0A (10 decimal)
 Number of bytes returned: 2
 Related Commands: AT (Guard Time After), CC (Command Sequence Character)

CC (Command Sequence Character) Command

<Command Mode Options> CC Command is used to set the ASCII character to be used between Guard Times of the AT Command Mode Sequence (BT+ CC + AT). The AT Command Mode Sequence activates AT Command Mode (from Idle Mode).

Refer to the AT Commands section [p19] to view the default AT Command Mode sequence.

AT Command: ATCC
 Binary Command: 0x13 (19 decimal)
 Parameter Range: 0x20 – 0x7F
 Default Parameter Value: 0x2B (ASCII “+” sign)
 Number of bytes returned: 1
 Related Commands: AT (Guard Time After), BT (Guard Time Before)

CD (DO3 Configuration) Command

<Command Mode Options> CD Command is used to redefine the behavior of the DO3/RX LED line.

AT Command: ATCD
 Binary Command: 0x28 (40 decimal)
 Parameter Range: 0 – 2

| Parameter Value | Configuration |
|-----------------|--|
| 0 | RX LED |
| 1 | Default high |
| 2 | Default low |
| 3 | (reserved) |
| 4 | Assert only when packet addressed to module sent |

Default Parameter Value: 0
 Number of bytes returned: 1
 Minimum Firmware Version Required: 4.2B

CN (Exit AT Command Mode) Command

<Command Mode Options> CN Command is used to explicitly exit AT Command Mode.

AT Command: ATCN
 Binary Command: 0x09 (9 decimal)

CS (DO2 Configuration) Command

<Serial Interfacing> CS Command is used to select the behavior of the DO2 pin signal. This output can provide RS-232 flow control, control the TX enable signal (for RS-485 or RS-422 operations), or set the default level for the I/O line passing function.

By default, DO2 provides RS-232 $\overline{\text{CTS}}$ (Clear-to-Send) flow control.

AT Command: ATCS
 Binary Command: 0x1F (31 decimal)
 Parameter Range: 0 – 4

| Parameter Value | Configuration |
|-----------------|---|
| 0 | RS-232 $\overline{\text{CTS}}$ flow control |
| 1 | RS-485 TX enable low |
| 2 | high |
| 3 | RS-485 TX enable high |
| 4 | low |

Default Parameter Value: 0
 Number of bytes returned: 1
 Related Commands: RT (DI2 Configuration), TO (DO2 Timeout)
 Minimum Firmware Version Required: 4.27D

CT (Command Mode Timeout) Command

<Command Mode Options> CT Command sets the amount of time before AT Command Mode terminates automatically. After a CT time of inactivity, the modem exits AT Command Mode and returns to Idle Mode. AT Command Mode can also be exited manually using CN (Exit AT Command Mode) Command.

AT Command: ATCT
 Binary Command: 0x06 (6 decimal)
 Parameter Range: 0x02 – 0xFFFF
 [x 100 milliseconds]
 Default Parameter Value: 0xC8 (200 decimal, 20 seconds)
 Number of bytes returned: 2

DT (Destination Address) Command

<Networking> DT Command is used to set the networking address of an XStream Modem. XStream Modems uses three network layers – Vendor Identification Number (ATID), Channels (ATHP), and Destination Addresses (ATDT). DT Command assigns an address to a modem that enables it to communicate only with other modems having the same addresses. All modems that share the same Destination Address can communicate freely with each other. Modems in the same network with a different Destination Address (than that of the transmitter) will listen to all transmissions to stay synchronized, but will not send any of the data out their serial ports.

AT Command: ATDT
 Binary Command: 0x00
 Parameter Range: 0 – 0xFFFF
 Default Parameter Value: 0
 Number of bytes returned: 2
 Related Commands: HP (Hopping Channel), ID (Modem VID), MK (Address Mask)

E0 (Echo Off) Command

<Command Mode Options> E0 Command turns off character echo in AT Command Mode. By default, echo is off.

AT Command: ATE0
 Binary Command: 0x0A (10 decimal)

E1 (Echo On) Command

<Command Mode Options> E1 Command turns on the echo in AT Command Mode. Each typed character will be echoed back to the terminal when ATE1 is active. E0 is the default.

AT Command: ATE1
 Binary Command: 0x0B (11 decimal)

ER (Receive Error Count) Command

<Diagnostics> Set/Read the receive-error. The error-count records the number of packets partially received then aborted on a reception error. This value returns to 0 after a reset and is not non-volatile (Value does not persist in the modem’s memory after a power-up sequence). Once the “Receive Error Count” reaches its maximum value (up to 0xFFFF), it remains at its maximum count value until the maximum count value is explicitly changed or the modem is reset.

AT Command: ATER
 Binary Command: 0x0F (15 decimal)
 Parameter Range: 0 – 0xFFFF
 Default Parameter Value: 0
 Number of bytes returned: 2
 Related Commands: GD (Receive Good Count)

FH (Force Wake-up Initializer) Command

<Sleep (Low Power)> FH Command is used to force a Wake-up Initializer to be sent on the next transmit. WR (Write) Command does not need to be issued with FH Command.

AT Command: ATFH
 Binary Command: 0x0D (13 decimal)

Use only with cyclic sleep modes active on remote modems.

FL (Software Flow Control) Command

<Serial Interfacing> FL Command is used to configure software flow control. Hardware flow control is implemented with the XStream Modem as the DO2 pin ($\overline{\text{CTS}}$), which regulates when serial data can be transferred to the modem. FL Command can be used to allow software flow control to also be enabled. XON character used is 0x11 (17 decimal). XOFF character used is 0x13 (19 decimal).

AT Command: ATFL

Binary Command: 0x07 (7 decimal)

Parameter Range: 0 - 1

| Parameter Value | Configuration |
|-----------------|-------------------------------|
| 0 | Disable software flow control |
| 1 | Enable software flow control |

Default Parameter Value: 0

Number of bytes returned: 1

FT (Flow Control Threshold) Command

<Serial Interfacing> Set/Read the flow control threshold. When FT bytes have accumulated in the DI buffer, $\overline{\text{CTS}}$ is de-asserted or the XOFF software flow control character is transmitted.

AT Command: ATFT

Binary Command: 0x24 (36 decimal)

Parameter Range: 0 - (Receiving modem DO buffer size minus 0x11 bytes)

Default Parameter Value: Receiving modem DO Buffer size minus 0x11

Number of bytes returned: 2

Minimum Firmware Version Required: 4.27B

GD (Receive Good Count) Command

<Diagnostics> Set/Read the count of good received RF packets. Parameter value is reset to 0 after every reset and is not non-volatile (Value does not persist in the modem's memory after a power-up sequence). Once the "Receive Good Count" reaches its maximum value (up to 0xFFFF), it remains at its maximum count value until the maximum count value is manually changed or the modem is reset.

AT Command: ATGD

Binary Command: 0x10 (16 decimal)

Parameter Range: 0 - 0xFFFF

Default Parameter Value: 0

Number of bytes returned: 2

Related Commands: ER (Receive Error Count)

HP (Hopping Channel) Command

<Networking> HP Command is used to set the modem's hopping channel number. A channel is one of three layers of addressing available to the XStream modem. In order for modems to communicate with each other, the modems must have the same channel number since each network uses a different hopping sequence. Different channels can be used to prevent modems in one network from listening to transmissions of another.

AT Command: ATHP

Binary Command: 0x11 (17 decimal)

Parameter Range: 0 - 6

Default Parameter Value: 0

Number of bytes returned: 1

Related Commands: DT (Destination Address), ID (Modem VID), MK (Address Mask)

HT (Time before Wake-up Initializer) Command

<<Sleep (Low Power)> If any modems within range are running in a “Cyclic Sleep” setting, a wake-up initializer must be used by the transmitting modem for sleeping modems to remain awake [refer to the LH (“Wake-up Initializer Timer”) Command]. When a receiving modem in Cyclic Sleep wakes, it must detect the wake-up initializer in order to remain awake and receive data. The value of HT Parameter tells the transmitter, “After a period of inactivity (no transmitting or receiving) lasting HT amount of time, send a long wake-up initializer”. HT Parameter should be set to match the inactivity timeout [specified by ST (Time before Sleep) Command] used by the receiver(s).

From the receiving modem perspective, after HT time elapses and the inactivity timeout [ST Command] is met, the receiver goes into cyclic sleep. In cyclic sleep, the receiver wakes once per sleep interval to check for a wake-up initializer. When a wake-up initializer is detected, the modem will stay awake to receive data. The wake-up initializer must be longer than the cyclic sleep interval to ensure that sleeping modems detect incoming data. When HT time elapses, the transmitter then knows that it needs to send a long Wake-up Initializer for all receivers to be able to remain awake and receive the next transmission. Matching HT to the time specified by ST on the receiving modem guarantees that all receivers will detect the next transmission.

AT Command: ATHT
 Binary Command: 0x03 (3 decimal)
 Parameter Range: 0 – 0xFFFF
 [x 100 milliseconds]
 Default Parameter Value: 0xFFFF (means that long wake-up initializer will not be sent)
 Number of bytes returned: 2
 Related Commands: LH (Wake-up Initializer Timer), SM (Sleep Mode), ST (Time before Sleep)

ID (Modem VID) Command

<Networking> Set/Read the “Vendor Identification Number”. Only modems with matching IDs can communicate with each other. Modules with non-matching VIDs will not receive unintended data transmission.

AT Command: ATID
 Binary Command: 0x27 (39 decimal)
 Parameter Range (user-settable):
 0x10 – 0x7FFFF
 (Factory-set and read-only):
 0x8000 – 0xFFFF
 Number of bytes returned: 2
 Minimum Firmware Version Required: 4.2B
 (Previous versions did not support user-settable VIDs)

LH (Wake-up Initializer Timer) Command

<Sleep (Low Power)> LH Command adjusts the duration of time for which the RF initializer is sent. When receiving modems are put into Cyclic Sleep Mode, they power-down after a period of inactivity [specified by ST (Time before Sleep) Command] and will periodically awaken and listen for transmitted data. In order for the receiving modems to remain awake, they must detect ~35ms of the wake-up initializer.

LH Command must be used whenever a receiver is operating in Cyclic Sleep Mode. This lengthens the Wake-up Initializer to a specific amount of time (in tenths of a second). The Wake-up Initializer Time must be longer than the cyclic sleep time that is determined by SM (Sleep Mode) Command. If the wake-up initializer time were less than the Cyclic Sleep interval, the connection would be at risk of missing the wake-up initializer transmission.

Refer to Figures 4.3 & 4.4 of the SM Command description to view diagrams of correct and incorrect configurations. The images help visualize the importance that the value of LH be greater than the value of SM.

AT Command: ATLH
 Binary Command: 0x0C (12 decimal)
 Parameter Range: 0 – 0xFF
 [x 100 milliseconds]
 Default Parameter Value: 1
 Number of bytes returned: 1
 Related Commands: HT (Time before Wake-up Initializer), SM (Sleep Mode), ST (Time before Sleep)

MK (Address Mask) Command

<Networking> MK Command is used to set/read the Address Mask.

All data packets contain the Destination Address of the transmitting modem. When an RF data packet is received, the transmitter’s Destination Address is logically “ANDed” (bitwise) with the Address Mask of the receiver. The resulting value must match the Destination Address or the Address Mask of the receiver for the packet to be received and sent out the modem’s DO serial port. If the “ANDed” value does not match either the Destination Address or the Address Mask of the receiver, the packet is discarded. (All “0” values are treated as “irrelevant” values and are ignored.)

AT Command: ATMK

Binary Command: 0x12 (18 decimal)

Parameter Range: 0 – 0xFFFF

Default Parameter Value: 0xFFFF
(Destination address (DT parameter) of the transmitting modem must exactly match the destination address of the receiving modem.)

Number of bytes returned: 2

Related Commands: DT (Destination Address), HP (Hopping Channel), ID (Modem VID), MY (Source Address)

NB (Parity) Command

<Serial Interfacing> Select/Read parity settings for UART communications.

AT Command: ATNB

Binary Command: 0x23 (35 decimal)

Parameter Range: 0 – 4

| Parameter Value | Configuration |
|-----------------|---|
| 0 | 8-bit (no parity or 7-bit (any parity)) |
| 1 | 8-bit even |
| 2 | 8-bit odd |
| 3 | 8-bit mark |
| 4 | 8-bit space |

Default Parameter Value: 0

Number of bytes returned: 1

Minimum Firmware Version Required: 4.27B

PC (Power-up to AT Mode) Command

<Command Mode Options> PC Command allows the modem to power-up directly into AT Command Mode from reset or power-on. If PC Command is enabled with SM Parameter set to 1, the DI3 Pin (SLEEP) can be used to enter the modem into AT Command Mode. When the DI3 pin is de-asserted (low), the modem will Wake-up into AT Command Mode. This behavior allows modem DTR emulation.

AT Command: ATPC

Binary Command: 0x1E (30 decimal)

Parameter Range: 0 – 1

| Parameter Value | Configuration |
|-----------------|-----------------------------|
| 0 | Power-up to Idle Mode |
| 1 | Power-up to AT Command Mode |

Default Parameter Value: 0

Number of bytes returned: 1

Minimum Firmware Version Required: 4.22

PW (Pin Wake-up) Command

<Sleep (Low Power)> Under normal operation, a modem in Cyclic Sleep Mode cycles from an active state to a low-power state at regular intervals until data is ready to be received. If the PW Parameter is set to 1, the SLEEP/DI3 Pin can be used to awaken the modem from Cyclic Sleep. If the SLEEP Pin is de-asserted (low), the modem will be fully operational and will not go into Cyclic Sleep. Once SLEEP is asserted, the modem will remain active for the period of time specified by ST (Time before Sleep) Command, and will return to Cyclic Sleep Mode (if no data is ready to be transmitted). PW Command is only valid if Cyclic Sleep has been enabled.

AT Command: ATPW

Binary Command: 0x1D (29 decimal)

Parameter Range: 0 - 1

| Parameter Value | Configuration |
|-----------------|---------------|
| 0 | Disabled |
| 1 | Enabled |

Default Parameter Value: 0

Number of bytes returned: 1

Related Commands: SM (Sleep Mode), ST (Time before Sleep)

Minimum Firmware Version Required: 4.22

RE (Restore Defaults) Command

<Diagnostics> RE Command restores all configurable parameters to factory default settings. However, RE Command will not write the default values to non-volatile (persistent) memory. Unless the WR (Write) Command is issued after the RE command, the default settings will not be saved in the event of modem reset or power-down.

AT Command: ATRE

Binary Command: 0x0E (14 decimal)

RN (Delay Slots) Command

<Networking> RN Command is only applicable if retries have been enabled [RR (Retries) Command], or if forced delays will be inserted into a transmission [refer to TT (Streaming Limit) Command]. RN Command is used to adjust the time delay that the transmitter inserts before attempting to resend a packet. If the transmitter fails to receive an acknowledgement after sending a packet, it will insert a random number of delay slots (ranging from 0 to (RN minus 1)) before attempting to resend the packet. Each delay slot lasts for a period of 38ms.

AT Command: ATRN

Binary Command: 0x19 (25 decimal)

Parameter Range: 0 - 0xFF [slots]

Default Parameter Value: 0 (no delay slots inserted)

Number of bytes returned: 1

Related Commands: RR (Retries), TT (Streaming Limit)

Minimum Firmware Version Required: 4.22

If two modems attempted to transmit at the same time, the random time delay after packet failure would allow one of the two modems to transmit the packet successfully, while the other would wait until the channel opens up to begin transmission.

RO (Packetization Timeout) Command

<Serial Interfacing> RO Command is used to specify/read the time of silence (no bytes received) after which transmission begins. After a serial byte is received and if no other byte is received before the RO timeout, the transmission will start.

AT Command: ATRO

Binary Command: 0x21 (33 decimal)

Parameter Range: 0 - 0xFFFF [x 200 μs]

Default Parameter Value: 0

Number of bytes returned: 2

Minimum Firmware Version Required: 4.2AA

RP (RSSI PWM Timer) Command

<Diagnostics> RP Command is used to enable a PWM (“Pulse Width Modulation”) output on the Config pin which is calibrated to show the level the received RF signal is above the sensitivity level of the modem. The PWM pulses vary from zero to 95 percent. Zero percent means the received RF signal is at or below the published sensitivity level of the modem. The following table shows levels above sensitivity and PWM values.

The total period of the PWM output is 8.32 ms. There are 40 steps in the PWM output and therefore the minimum step size is 0.208 ms.

Table 4-02. PWM Chart

| dBm above Sensitivity | PWM percentage (high period / total period) |
|-----------------------|---|
| 10 | 47.5% |
| 20 | 62.5% |
| 30 | 77.5% |

A non-zero value defines the time that the PWM output will be active with the RSSI value of the last received RF packet. After the set time when no RF packets are received, the PWM output will be set low (0 percent PWM) until another RF packet is received. The PWM output will also be set low at power-up. A parameter value of 0xFF permanently enables the PWM output and it will always reflect the value of the last received RF packet.

PWM output shares the Config input pin. When the modem is powered, the Config pin will be an input. During the power-up sequence, the Config pin will be read to determine whether the modem is going into AT Command Mode. After this, if RP parameter is a non-zero value, the Config pin will be configured as an output and set low until the first RF packet is received. With a non-zero RP parameter, the Config pin will be an input for RP ms after power up.

AT Command: ATRP

Binary Command: 0x22 (34 decimal)

Parameter Range: 0 – 0x7F
[x 100 milliseconds]

Default Parameter Value: 0 (disabled)

Number of bytes returned: 1

Minimum Firmware Version Required: 4.2AA

RR (Retries) Command

Networking> RR Command specifies the number of retries that can be sent for a given RF packet. Once RR Command is enabled (set to a non-zero value), RF packet acknowledgements and retries are enabled. After transmitting a packet, the transmitter will wait to receive an acknowledgement from a receiver. If the acknowledgement is not received in the period of time specified by the RN (Delay Slots) Command, the transmitter will transmit the original packet again. The packet will be transmitted repeatedly until an acknowledgement is received or until the packet has been sent RR times.

Note: For retries to work correctly, all modems in the system must have retries enabled.

AT Command: ATRR

Binary Command: 0x18 (24 decimal)

Parameter Range: 0 – 0xFF

Default Parameter Value: 0 (disabled)

Number of bytes returned: 1

Minimum Firmware Version Required: 4.22

RS (RSSI) Command

<Diagnostics> RS Command returns the signal level of the last packet received. This reading is useful for determining range characteristics of the XStream Modems under various conditions of noise and distance.

Once the command is issued, the modem will return a value between 0x6 and 0x36 where 0x36 represents a very strong signal level and 0x4 indicates a low signal level.

AT Command: ATRS

Binary Command: 0x1C (28 decimal)

Parameter Range: 0x06 – 0x36 [Read-only]

Number of bytes returned: 1

Minimum Firmware Version Required: 4.22

RT (DI2 Configuration) Command

<Serial Interfacing> RT command is used to dictate the behavior of the DI2/RTS/CMD line. RT Command must be issued to enable RTS flow control or binary programming.

AT Command: ATRT

Binary Command: 0x16 (22 decimal)

Parameter Range: 0 – 2

| Parameter Value | Configuration |
|-----------------|--------------------------------|
| 0 | disabled |
| 1 | Enable Binary Programming |
| 2 | Enable <u>RTS</u> Flow Control |

Default Parameter Value: 0

Number of bytes returned: 1

SB (Stop Bits) Command

SB Command is used to set/read the number of stop bits in the data packets.

AT Command: ATSB

Binary Command: 0x36 (54 decimal)

Parameter Range: 0 – 1

| Parameter Value | Configuration |
|-----------------|---------------|
| 0 | 1 stop bits |
| 1 | 2 stop bits |

Default Parameter Value: 0

Number of bytes returned: 1

Minimum Firmware Version Required: 4.2B

SH (Serial Number High) Command

<Diagnostics> Set/Read the serial number high word of the modem.

AT Command: ATSH

Binary Command: 0x25 (37 decimal)

Parameter Range: 0 – 0xFFFF [Read-only]

Number of bytes returned: 2

Related Commands: SL (Serial Number Low)

Minimum Firmware Version Required: 4.27C

SL (Serial Number Low) Command

<Diagnostics> Set/Read the serial number low word of the modem.

AT Command: ATSL

Binary Command: 0x26 (38 decimal)

Parameter Range: 0 – 0xFFFF [Read-only]

Number of bytes returned: 2

Related Commands: SH (Serial Number High)

Minimum Firmware Version Required: 4.27C

SM (Sleep Mode) Command

<Sleep Mode (Low Power)> SM Command is used to adjust Sleep Mode settings. By default, Sleep Mode is disabled and the modem remains continually active. SM Command allows the modem to run in a lower-power state and be configured in one of eight settings.

Cyclic Sleep settings wake the modem after the amount of time designated by SM Command. If the modem detects a wake-up initializer during the time it is awake, it will synchronize with the transmitter and start receiving data after the wake-up initializer runs its duration. Otherwise, it returns to Sleep Mode and continue to cycle in and out of inactivity until the Wake-up Initializer is detected. If a Cyclic Sleep setting is chosen, the ST, LH and HT parameters must also be set as described in the "Sleep Modes" section of this manual.

Refer to the "Sleep Modes" section [p16] for more information.

AT Command: ATSM

Binary Command: 0x01

Parameter Range: 0 – 8

| Parameter Value | Configuration |
|-----------------|---|
| 0 | Disabled |
| 1 | Pin Sleep |
| 2 | Serial Port Sleep |
| 3 | Cyclic 0.5 second sleep (Modem wakes every 0.5 seconds) |
| 4 | Cyclic 1.0 second sleep |
| 5 | Cyclic 2.0 second sleep |
| 6 | Cyclic 4.0 second sleep |
| 7 | Cyclic 8.0 second sleep |
| 8 | Cyclic 16.0 second sleep |

Default Parameter Value: 0

Number of bytes returned: 1

Related Commands:

For Pin Sleep – PC (Power-up Mode), PW (Pin Wake-up)

For Serial Port Sleep – ST (Time before Sleep)

For Cyclic Sleep – ST (Time before Sleep), LH (Wake-up Initializer Timer), HT (Time Before Wake-up Initializer), PW (Pin Wake-up)

ST (Time before Sleep) Command

<Sleep Mode (Low Power)> ST Command sets the period of time (in tenths of seconds) in which the modem remains inactive before entering into Sleep Mode. For example, if the ST Parameter is set to 0x64 (100 decimal), the modem will enter into Sleep mode after 10 seconds of inactivity (no transmitting or receiving). This command can only be used if Cyclic Sleep or Serial Port Sleep Mode settings have been selected using SM (Sleep Mode) Command.

AT Command: ATST

Binary Command: 0x02

Parameter Range: 0x10 – 0xFFFF
[x 100 milliseconds]

Default Parameter Value: 0x64 (100 decimal)

Number of bytes returned: 2

Related Commands: SM (Sleep Mode), LH (Wake-up Initializer Timer), HT (Time before Wake-up Initializer)

SY (Time before Initialization) Command

<Networking> SY Command keeps a communication channel open as long as modem transmits or receives before the active connection expires. It can be used to reduce latency in a query/response sequence and should be set 100 ms longer than the delay between transmissions.

This command allows multiple XStream Modems to share a hopping channel for a given amount of time after receiving data. By default, all packets include an RF initializer that contains channel information used to synchronize any listening receivers to the transmitter's hopping pattern. Once a new modem comes within range or is powered on within range, it is able to instantly synchronize to the transmitter and start receiving data. If no new modems are introduced into the system, the synchronization information becomes redundant once modems have become synchronized.

AT Command: ATSY

Binary Command: 0x17 (23 decimal)

Parameter Range: 0 – 0xFF
[x 100 milliseconds]

Default Parameter Value: 0 (Disabled – channel initialization information is sent with each RF packet.)

Number of bytes returned: 1

SY Command allows the modems to remove this information from the RF Initializer after the initial synchronization. For example, changing the SY Parameter to 0x14 (20 decimal) allows all modems to remain in sync for 2 seconds after the last data packet was received. Synchronization information is not re-sent unless transmission stops for more than 2 seconds. This command allows significant savings in packet transmission time.

Warning: Not recommended for use in an interference-prone environment. Interference can break up the session and the communications channel will not be available again until SY time expires.

With SY set to zero, the channel session is opened and closed with each transmission - resulting in a more robust link with more latency.

TR (Transmit Error Count) Command

<Diagnostics> TR Command records the number of retransmit failures. This number is incremented each time a packet is not acknowledged within the number of retransmits specified by the RR (Retries) Command. It therefore counts the number of packets that were not successfully received and have been dropped. The TR Parameter is not non-volatile and will therefore be reset to zero each time the modem is reset.

AT Command: ATTR
 Binary Command: 0x1B (27 decimal)
 Parameter Range: 0 - 0xFFFF
 Default Parameter Value: 0
 Number of bytes returned: 2
 Related Commands: RR (Retries)
 Minimum Firmware Version Required: 4.22

TT (Streaming Limit) Command

<Networking> TT Command defines a limit on the number of bytes that can be sent out before a random delay is issued. TT Command is used to simulate full-duplex behavior. If a modem is sending a continuous stream of RF data, a delay is inserted which stops its transmission and allows other modems time to transmit (once it sends number of bytes specified by TT Command). Inserted random delay lasts between 1 & 'RN + 1' delay slots, where each delay slot lasts 38ms.

AT Command: ATTT
 Binary Command: 0x1A (26 decimal)
 Parameter Range: 0 - 0xFFFF (0 = disabled)
 Default Parameter Value: 0xFFFF (65535 decimal)
 Number of bytes returned: 2
 Related Commands: RN (Delay Slots)
 Minimum Firmware Version Required: 4.22

VR (Firmware Version) Command

<Diagnostics> Read the Firmware Version of the XStream Modem.

AT Command: ATVR
 Binary Command: 0x14 (20 decimal)
 Parameter Range: 0 - 0xFFFF [Read-only]
 Number of bytes returned: 2

WR (Write) Command

<(Special)> WR Command writes configurable parameters to the modem's non-volatile memory (Parameter values persist in the modem's memory until overwritten by future use of WR Command).

AT Command: ATWR
 Binary Command: 0x08

If changes are made without writing them to non-volatile memory, the modem reverts back to previously saved parameters the next time the modem is powered-on.

Appendix A: Agency Certifications

FCC Certification

The XStream RF Modem complies with Part 15 of the FCC rules and regulations. Compliance with the labeling requirements, FCC notices and antenna usage guidelines is required.

To fulfill the FCC Certification requirements, the OEM must comply with the following FCC regulations:

1. The system integrator must ensure that the text on the external label provided with this device is placed on the outside of the final product [Figure A.1 for 900 MHz operations or Figure A.2 for 2.4 GHz operations].
2. The XStream RF Modem may be used only with Approved Antennas that have been tested with this modem. [Table A.1 or Table A.2]

FCC Notices:

IMPORTANT: The 9XStream (900 MHz) and 24XStream (2.4 GHz) OEM Modems have been certified by the FCC for use with other products without any further certification (as per FCC section 2.1091). Changes or modifications not expressly approved by MaxStream could void the user's authority to operate the equipment.

IMPORTANT: OEMs must test their final product to comply with unintentional radiators (FCC section 15.107 and 15.109) before declaring compliance of their final product to Part 15 of the FCC Rules.

IMPORTANT: The XStream RF Modems have been certified for remote and base radio applications. If the XStream will be used for portable applications, the device must undergo SAR testing.

This equipment has been tested and found to comply with the limits for a Class B digital device, pursuant to Part 15 of the FCC Rules. These limits are designed to provide reasonable protection against harmful interference in a residential installation. This equipment generates, uses and can radiate radio frequency energy and, if not installed and used in accordance with the instructions, may cause harmful interference to radio communications. However, there is no guarantee that interference will not occur in a particular installation. If this equipment does cause harmful interference to radio or television reception, which can be determined by turning the equipment off and on, the user is encouraged to try to correct the interference by one or more of the following measures:

- Re-orient or relocate the receiving antenna.
- Increase the separation between the equipment and receiver.
- Connect the equipment into an outlet on a circuit different from that to which the receiver is connected.
- Consult the dealer or an experienced radio/TV technician for help.

OEM Labeling Requirements

Label Warning

 **WARNING** The Original Equipment Manufacturer (OEM) must ensure that FCC labeling requirements are met. This includes a clearly visible label on the outside of the final product enclosure that displays the contents shown in the figure below.

Figure A.1. Required FCC Label for OEM products containing 9XStream (900 MHz) RF Modem

Contains FCC ID: OUR9XSTREAM
The enclosed device complies with Part 15 of the FCC Rules. Operation is subject to the following two conditions: (1) this device may not cause harmful interference and (2) this device must accept any interference received, including interference that may cause undesired operation.

Figure A.2. Required FCC Label for OEM products containing 24XStream (2.4 GHz) RF Modem

Contains FCC ID: OUR-24XSTREAM
The enclosed device complies with Part 15 of the FCC Rules. Operation is subject to the following two conditions: (1) this device may not cause harmful interference and (2) this device must accept any interference received, including interference that may cause undesired operation.

Antenna Usage

Antenna Warning

 **WARNING:** This device has been tested with Reverse Polarity SMA connectors with the antennas listed in Tables A.1 & A.2 of Appendix A. When integrated in OEM products, fixed antennas require installation preventing end-users from replacing them with non-approved antennas. Antennas not listed in the tables must be tested to comply with FCC Section 15.203 (unique antenna connectors) and Section 15.247 (emissions).

RF Exposure

 **WARNING:** This equipment is approved only for mobile and base station transmitting devices, separation distances of (i) 20 centimeters or more for antennas with gains < 6 dBi or (ii) 2 meters or more for antennas with gains \geq 6 dBi should be maintained between the antenna of this device and nearby persons during operation. To ensure compliance, operation at distances closer than this is not recommended.

The preceding statement must be included as a CAUTION statement in manuals for OEM products to alert users on FCC RF Exposure compliance.

MaxStream radio modems are pre-FCC approved for use in fixed base station and mobile applications. As long as the antenna is mounted at least 20 cm (8 in) from nearby persons, the application is considered a mobile application. If the antenna will be mounted closer than 20 cm to nearby persons, then the application is considered "portable" and requires an additional test performed on the final product. This test is called the Specific Absorption Rate (SAR) testing and measures the emissions from the radio modem and how they affect the person.

Over 100 additional antennas have been tested and are approved for use with MaxStream 900 MHz Radio Modems (including "Mag Mount", "Dome", "Multi-path" and "Panel" antennas). Because of the large number of approved antennas, MaxStream requests that you send specific information about an antenna you would like to use with the modem and MaxStream will evaluate whether the antenna is covered under our FCC filing.

FCC-Approved Antennas

Table A.1. Antennas approved for use with 9XStream (900 MHz) RF Modems.

| Manufacturer | Part Number | Type | Gain | Application | Min. Separation Distance |
|--------------|-----------------------|----------------------------------|----------|-----------------|--------------------------|
| * | * | Yagi | 6.2 dBi | Fixed/Mobile ** | 20 cm |
| * | * | Yagi | 7.2 dBi | Fixed/Mobile ** | 20 cm |
| MaxStream | A09-Y8 | Yagi | 8.2 dBi | Fixed/Mobile ** | 20 cm |
| * | * | Yagi | 9.2 dBi | Fixed/Mobile ** | 20 cm |
| * | * | Yagi | 10.2 dBi | Fixed/Mobile ** | 20 cm |
| MaxStream | A09-Y11 (FCC pending) | Yagi | 11.2 dBi | Fixed/Mobile ** | 20 cm |
| MaxStream | A09-F2 | Omni Direct. | 2.2 dBi | Fixed ** | 20 cm |
| MaxStream | A09-F5 | Omni Direct. | 5.2 dBi | Fixed ** | 20 cm |
| MaxStream | A09-F8 | Omni Direct. | 8.2 dBi | Fixed ** | 20 cm |
| * | * | Omni Direct. | 9.2 dBi | Fixed ** | 20 cm |
| * | * | Omni Direct. | 7.2 dBi | Fixed ** | 20 cm |
| MaxStream | A09-M7 | Omni Direct. | 7.2 dBi | Fixed ** | 20 cm |
| MaxStream | A09-H | 1/2 wave antenna | 2.1 dBi | Fixed/Mobile ** | 20 cm |
| MaxStream | A09-HBMM-P5I | 1/2 wave antenna | 2.1 dBi | Fixed/Mobile ** | 1 cm |
| MaxStream | A09-OBMM-P5I | 1/4 wave antenna | 1.9 dBi | Fixed/Mobile ** | 1 cm |
| * | * | 1/4 wave integrated wire antenna | 1.9 dBi | Fixed/Mobile ** | 1 cm |

Table A.2. Antennas approved for use with 24XStream (2.4 GHz) RF Modems.

| Manufacturer | Part Number | Type | Gain | Application | Min. Separation Distance |
|--------------|---------------|-------------|----------|-----------------|--------------------------|
| * | * | Yagi | 6 dBi | Fixed ** | 2 m |
| * | * | Yagi | 8.8 dBi | Fixed ** | 2 m |
| * | * | Yagi | 9 dBi | Fixed ** | 2 m |
| * | * | Yagi | 10 dBi | Fixed ** | 2 m |
| * | * | Yagi | 11 dBi | Fixed ** | 2 m |
| * | * | Yagi | 12 dBi | Fixed ** | 2 m |
| * | * | Yagi | 12.5 dBi | Fixed ** | 2 m |
| * | * | Yagi | 13.5 dBi | Fixed ** | 2 m |
| * | * | Yagi | 15 dBi | Fixed ** | 2 m |
| * | * | Omni Direct | 2.1 dBi | Fixed/Mobile ** | 20 cm |
| * | * | Omni Direct | 3 dBi | Fixed/Mobile ** | 20 cm |
| * | * | Omni Direct | 5 dBi | Fixed/Mobile ** | 20 cm |
| * | * | Omni Direct | 7.2 dBi | Fixed ** | 2 m |
| * | * | Omni Direct | 8 dBi | Fixed ** | 2 m |
| * | * | Omni Direct | 9.5 dBi | Fixed ** | 2 m |
| * | * | Omni Direct | 10 dBi | Fixed ** | 2 m |
| * | * | Omni Direct | 12 dBi | Fixed ** | 2 m |
| * | * | Omni Direct | 15 dBi | Fixed ** | 2 m |
| MaxStream | A24-P8 | Panel | 8.5 dBi | Fixed ** | 2 m |
| MaxStream | A24-P13 | Panel | 13 dBi | Fixed ** | 2 m |
| * | * | Panel | 14 dBi | Fixed ** | 2 m |
| * | * | Panel | 15 dBi | Fixed ** | 2 m |
| * | * | Panel | 16 dBi | Fixed ** | 2 m |
| MaxStream | A24-P19 | Panel | 19 dBi | Fixed ** | 2 m |
| MaxStream | A24-HABMM-P6I | Dipole | 2.1 dBi | Fixed/Mobile ** | 20 cm |
| MaxStream | A24-HBMM-P6I | Dipole | 2.1 dBi | Fixed/Mobile ** | 20 cm |
| MaxStream | A24-HABSM | Dipole | 2.1 dBi | Fixed/Mobile ** | 20 cm |
| MaxStream | A24-QABMM-P6I | Monopole | 1.9 dBi | Fixed/Mobile ** | 20 cm |
| * | A24-Q1 | Monopole | 1.9 dBi | Fixed/Mobile ** | 20 cm |
| * | * | Monopole | 1.9 dBi | Fixed/Mobile ** | 20cm |

* FCC-approved antennas not inventoried by MaxStream – Contact MaxStream (866) 765-9885 for information.

** Can be approved for portable applications if integrator gains approval through SAR testing

European Compliance (2.4 GHz only)

The 24XStream has been certified for use in several European countries. For a complete list, refer to <http://www.maxstream.net>.

If the 24XStream modems are incorporated into a product, the manufacturer must ensure compliance of the final product to the European harmonized EMC and low-voltage/safety standards. A Declaration of Conformity must be issued for each of these standards and kept on file as described in Annex II of the R&TTE Directive. Furthermore, the manufacturer must maintain a copy of the XStream user manual documentation and ensure the final product does not exceed the specified power ratings, antenna specifications, and/or installation requirements as specified in the user manual. If any of these specifications are exceeded in the final product, a submission must be made to a notified body for compliance testing to all required standards.

OEM Labeling Requirements

The 'CE' marking must be affixed to a visible location on the OEM product.

Figure A.3. CE Labeling Requirements

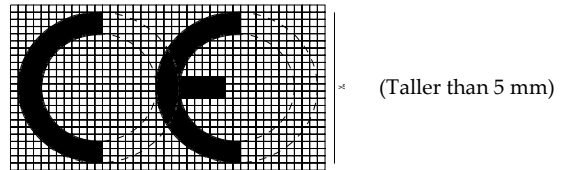

The CE mark shall consist of the initials "CE" taking the following form:

- If the CE marking is reduced or enlarged, the proportions given in the above graduated drawing must be respected.
- The CE marking must have a height of at least 5mm except where this is not possible on account of the nature of the apparatus.
- The CE marking must be affixed visibly, legibly, and indelibly.

Furthermore, since the usage of the 2400 – 2483.5 MHz band is not harmonized throughout Europe, the Restriction sign must be placed to the right of the 'CE' marking as shown below. See the R&TTE Directive, Article 12 and Annex VII for more information

Figure A.4. CE Label Required on OEM Equipment



Restrictions

France – France imposes restrictions on the 2.4 GHz band. Go to www.art-telecom.fr or contact MaxStream for more information.

Norway – Norway prohibits operation near Ny-Alesund in Svalbard. More information can be found at the Norway Posts and Telecommunications site (www.npt.no).

24XStream Declarations of Conformity

MaxStream has issued Declarations of Conformity for the 24XStream modems concerning emissions, EMC and safety. Files are located in the 'documentation' folder of the MaxStream CD.

Important Note

MaxStream does not list the entire set of standards that must be met for each country. MaxStream customers assume full responsibility for learning and meeting the required guidelines for each country in their distribution market. For more information relating to European compliance of an OEM product incorporating the 24XStream modem, contact MaxStream, or refer to the following web sites:

CEPT ERC 70-03E – Technical Requirements, European restrictions and general requirements: Available at www.ero.dk/

R&TTE Directive – Equipment requirements, placement on market: Available at www.ero.dk/

Notifications and Required Information

Since the 2.4 GHz band is not harmonized throughout Europe, a notification must be sent to each country prior to shipping product according to Article 6.4 of the R&TTE Directive. A list of national contacts for most European countries may be found at www.ero.dk/.

The following technical data (relating to the 24XStream) is often required in filling out a notification form.

- Frequency Band: 2400.0 – 2483.5 MHz
- Modulation: Frequency Shift Keying
- Channel Spacing: 400 kHz
- ITU Classification: 400KF1D
- Output Power: 100 mW EIRP
- Notified Body Number: 0891

Contact MaxStream (801) 765-9885 if additional information is required.

Europe (2.4 GHz) Approved Antenna List

Table A.3. Antennas approved for use with 24XStream (2.4 GHz) RF Modems in Europe

| Manufacturer | Part Number | Type | Gain | Application | Minimum Separation Distance |
|--------------|---------------|----------|---------|----------------|-----------------------------|
| MaxStream | A24-HABMM-P6I | Dipole | 2.1 dBi | Fixed/Mobile * | 20cm |
| MaxStream | A24-HBMM-P6I | Dipole | 2.1 dBi | Fixed/Mobile * | 20cm |
| MaxStream | A24-HABSM | Dipole | 2.1 dBi | Fixed/Mobile * | 20cm |
| MaxStream | A24-QABMM-P6I | Monopole | 1.9 dBi | Fixed/Mobile * | 20cm |
| MaxStream | A24-QBMM-P6I | Monopole | 1.9 dBi | Fixed/Mobile * | 20cm |
| MaxStream | A24-Q1 | Monopole | 1.9 dBi | Fixed/Mobile * | 20cm |

* Can be approved for portable applications if integrator gains approval through SAR testing

IC (Industry Canada) Certification

Labeling requirements for Industry Canada are similar to those of the FCC. A clearly visible label on the outside of the final product enclosure must display the following text:

Contains Model 9XStream Radio (900 MHz), IC: 4214A-9XSTREAM
Contains Model 24XStream Radio (2.4 GHz), IC: 4214A 12008

Integrator is responsible for its product to comply with IC ICES-003 & FCC Part 15, Sub. B - Unintentional Radiators. ICES-003 is the same as FCC Part 15 Sub. B and Industry Canada accepts FCC test report or CISPR 22 test report for compliance with ICES-003.

Appendix B: Development Guide

RS-232 Accessories Kit Contents

The accessories listed below are included with XStream RF Modems that carry the “-RA” suffix on the product number. For example: Part number “X09-019PKC-RA” includes the listed accessories and part number “X09-019PKC-R” does not. The accessories kit includes hardware and software needed for developing long range wireless links. For testing the modem’s range, MaxStream recommends the purchase of one RF Modem with the accessories and one without.

Table B.1. Accessories Kit Contents

| Item | Qty. | Description | Part Number |
|--|------|---|---------------------|
| Quick Start Guide | 1 | Familiarizes users with some of the modem's most important functions. | MD0019 |
| CD | 1 | Contains documentation, software and tools needed for RF operation. | MD0030 |
| XStream-PKG-R™ RS-232/485 RF Modem | 1 | Long Range RF Modem with RPSMA Connector | X09... or X19... |
| Antenna | 1 | RPSMA, 6" Half-Wave, dipole, articulating | A09-HASM-675 |
| Serial Loopback Adapter | 1 | Connects to the female RS-232 (DB-9) serial connector of the Interface Board and can be used to configure the modem to function as a repeater (for range testing) | JD2D3-CDL-A |
| NULL Modem Adapter (male-to-male) | 1 | Connects to the female RS-232 (DB-9) serial connector of the Interface Board and can be used to connect the modem to another DCE (female DB9) device | JD2D2-CDN-A |
| NULL Modem Adapter (female-to-female) | 1 | Used to bypass radios to verify serial cabling is functioning properly | JD3D3-CDN-A |
| Male DB-9 to RJ-45 Adapter | 1 | Facilitates adapting the DB-9 Connector of the Interface Board to a CAT5 cable (male DB9 to female RJ45) | JE1D2-CDA-A |
| Female DB-9 to RJ-45 Adapter | 1 | Facilitates adapting the DB-9 Connector of the Interface Board to a CAT5 cable (female DB9 to female RJ45) | JE1D3-CDA-A |
| Power Adapter | 1 | Allows Interface Board to be powered by a 110 Volt AC power supply | JP4P2-9V10-6F |
| RS-232 Cable (6') | 1 | Connects interface board to devices having an RS-232 serial port | JD2D3-CDS-6F |

Adapters

The XStream Development Kit comes with several adapters that support the following functions:

- Performing Range Tests (Serial Loopback)
- Connecting to other RS-232 DCE and DTE devices (Male-to-Male NULL modem)
- Testing Cables (Female-to-Female NULL modem)
- Connecting to terminal blocks or RJ-45 (for RS-485/422 devices)

Serial Loopback Adapter

Part Number: JD2D3-CDL-A (Red, DB-9 M-F) The serial loopback adapter is used for range testing. During a range test, the serial loopback adapter configures the radio modem to function as a repeater by looping serial data back into the radio for retransmission.

Figure B.1. Serial loopback adapter and pinouts

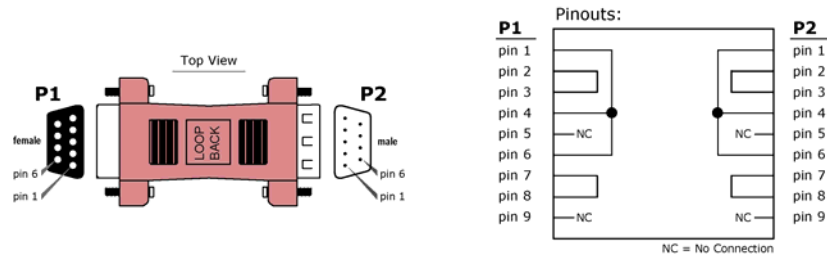

NULL Modem Adapter (male-to-male)

Part Number: JD2D2-CDN-A (Black, DB-9 M-M) The male-to-male NULL modem adapter is used to connect two DCE devices. A DCE device connects with a straight-through cable to the male serial port of a computer (DTE).

Figure B.2. Male NULL modem adapter and pinouts

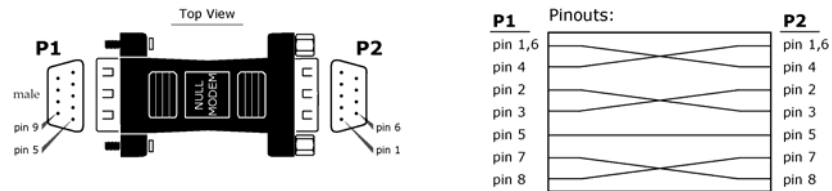

Figure B.3. Example of a MaxStream Radio Modem (DCE Device) connecting to another DCE device)



NULL Modem Adapter (female-to-female)

Part Number: JD3D3-CDN-A (Gray, DB-9 F-F) The female-to-female NULL modem adapter is used to verify serial cabling is functioning properly. To test cables, insert the female-to-female NULL modem adapter in place of a pair of modem assemblies (XIB-R-R interface board + XStream Modem) and test the connection without radio modems in the connection.

Figure B.4. Female NULL modem adapter and pinouts

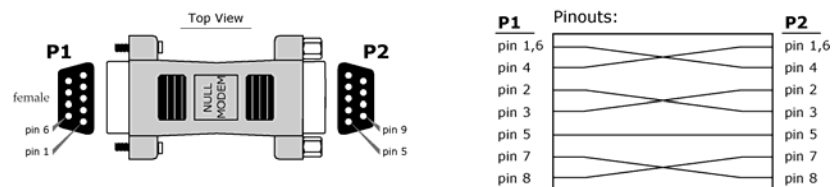

For use in RS-485/422 systems: DB-9 to RJ-45 adapters are illustrated on p11.

Antennas

[Refer to Appendix A for a list of FCC-Approved Antennas]

Factors that determine wireless link range:

- Ambient RF noise (interference)
- Line-of-sight obstructions
- Transmit power
- Receive sensitivity
- Antenna configuration
- XStream Antenna Connector Options

To comply with the FCC rules and obtain a “modular” certification, it is required that XStream Modems utilize a “non-standard” connector. This is to ensure the modems are used only with approved antennas.

RPSMA

The Reverse Polarity SMA (RPSMA) connector uses the same body as a regular SMA connector. In order to be a “non standard” connector, the gender of the center conductor is changed. The female RPSMA actually has a male center conductor.



Antenna Cables

RF cables are typically used to connect a radio installed in a cabinet to an antenna mounted externally. As a general rule, it is best to keep the RF cable as short as possible. All cables promote signal loss which is usually measured in dB loss per 100 ft. MaxStream provides LMR-195 rated cables. Common cables and dB losses are included in this table:

Table B.2. Potential Signal Strength Loss due to Antenna Cable Length

| Cable Type | Loss at 900 MHz per 100' (loss per 100m) | Loss at 2.4 GHz per 100' (loss per 100m) | Diameter |
|------------|--|--|-----------------|
| RG-58 | 14.5 dB (47.4 dB) | 25.3 dB (83.2 dB) | 0.20" (4.95 mm) |
| RG-174 | 25.9 dB (85.0 dB) | 44.4 dB (145.8 dB) | 0.10" (2.54 mm) |
| RG-316 | 24.7 dB (81.0 dB) | 42.4 dB (139.0 dB) | 0.10" (2.59 mm) |
| LMR-195 | 11.1 dB (36.5 dB) | 19.0 dB (62.4 dB) | 0.20" (4.95 mm) |
| LMR-240 | 7.6 dB (24.8 dB) | 12.9 dB (42.4 dB) | 0.24" (6.10 mm) |
| LMR-600 | 2.5 dB (8.2 dB) | 4.4 dB (14.5 dB) | 0.59" (15.0 mm) |

Appendix C: Additional Information

1-Year Warranty

XStream RF Modems from MaxStream, Inc. (the "Product") are warranted against defects in materials and workmanship under normal use, for a period of 1-year from the date of purchase. In the event of a product failure due to materials or workmanship, MaxStream will repair or replace the defective product. For warranty service, return the defective product to MaxStream, shipping prepaid, for prompt repair or replacement.

The foregoing sets forth the full extent of MaxStream's warranties regarding the Product. Repair or replacement at MaxStream's option is the exclusive remedy. THIS WARRANTY IS GIVEN IN LIEU OF ALL OTHER WARRANTIES, EXPRESS OR IMPLIED, AND MAXSTREAM SPECIFICALLY DISCLAIMS ALL WARRANTIES OF MERCHANTABILITY OR FITNESS FOR A PARTICULAR PURPOSE. IN NO EVENT SHALL MAXSTREAM, ITS SUPPLIERS OR LICENSORS BE LIABLE FOR DAMAGES IN EXCESS OF THE PURCHASE PRICE OF THE PRODUCT, FOR ANY LOSS OF USE, LOSS OF TIME, INCONVENIENCE, COMMERCIAL LOSS, LOST PROFITS OR SAVINGS, OR OTHER INCIDENTAL, SPECIAL OR CONSEQUENTIAL DAMAGES ARISING OUT OF THE USE OR INABILITY TO USE THE PRODUCT, TO THE FULL EXTENT SUCH MAY BE DISCLAIMED BY LAW. SOME STATES DO NOT ALLOW THE EXCLUSION OR LIMITATION OF INCIDENTAL OR CONSEQUENTIAL DAMAGES. THEREFOR, THE FOREGOING EXCLUSIONS MAY NOT APPLY IN ALL CASES. This warranty provides specific legal rights. Other rights which vary from state to state may also apply.

Ordering Information

Figure C.1 MaxStream RF Modem Part Numbers Key

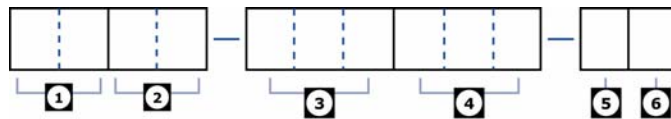

Divisions of the MaxStream PKG RF Modem part numbers:

1 MaxStream Product Family

XC = XCite
X = XStream
XT = XTend

2 Operating Frequency

09 = 902-928 MHz
24 = 2.4000 - 2.4835 GHz
(XStream only)
H9 = 923 MHz (XStream only)

3 Throughput Data Rate

001 = 1200 bps (XStream only)
009 = 9600 bps
019 = 19200 bps (XStream only)
038 = 38400 bps (XCite Only)
(blank) All XTend RF Modems support
9600 & 115200 bps (software selectable)

4 Operating Temperature

PKC = Commercial: 0 to 70° C
PKI = Industrial: -40 to 85° C. Embedded RF Module is Conformal Coated
PKT = Tested Industrial: -40 to 85° C. Embedded RF Module
is Conformal Coated & 100% tested

5 Serial Interface (Connector)

R = RS-232, RS-485/422
U = USB
E = Ethernet
T = Telephone

6 Accessories Package

A = Accessories Package (specific to the Serial Interface) Included
(blank) means the accessories package is not included

Contact MaxStream

Free and unlimited technical support is included with every MaxStream Radio Modem sold.
Please use the following resources for additional support:

| | |
|--------------------|--|
| Documentation: | www.maxstream.net/support |
| Technical Support: | Phone. (866) 765-9885 toll-free U.S. & Canada (801) 765-9885 Worldwide |
| | Live Chat. www.maxstream.net |
| | E-Mail. rf-xperts@maxstream.net |

MaxStream office hours are 8:00 am – 5:00 pm [U.S. Mountain Standard Time]