



**Connectware™**

**Digi One/PortServer TS 2/4**

**Configuration and Administration  
Guide**

The Digi logo is a trademark of Digi International.

All other brand and product names are trademarks of their respective holders.

© Digi International Inc., 1998, 2000, 2001, 2002. All Rights Reserved

<http://www.digi.com>

Information in this document is subject to change without notice and does not represent a commitment on the part of Digi International.

Digi provides this document “as is”, without warranty of any kind, either expressed or implied, including, but not limited to, the implied warranties of fitness or merchantability for a particular purpose. Digi may make improvements and/or changes in this manual or in the product(s) and/or the program(s) described in this manual at any time.

This product could include technical inaccuracies or typographical errors. Changes are periodically made to the information herein; these changes may be incorporated in new editions of the publication.

<b>Chapter 1 Configuring the IP Address</b>	
Options for Configuring the IP Address and Mask.....	1-2
Configuring an IP Address and Mask from the Command Line .....	1-2
Configuring an IP Address using DHCP and RARP.....	1-2
Configuring a Default Gateway .....	1-3
<b>Chapter 2 Configuring Users</b>	
About Configuring Users.....	2-2
Common User Features.....	2-2
Configuring a User: Web Interface .....	2-2
Configuring a User: Command Line Examples.....	2-4
<b>Chapter 3 Configuring Ports for RealPort</b>	
About RealPort.....	3-2
Configuring Ports: Web Interface .....	3-3
Configuring Ports for RealPort: Command Line .....	3-4
<b>Chapter 4 Configuring Ports for Printers</b>	
Configuration Considerations .....	4-2
Configuring Ports: Web Interface .....	4-4
Configuring Printer Connections: Command Line .....	4-4
Configuring a Port for Direct-Access Printing .....	4-5
<b>Chapter 5 Configuring Ports for Modems</b>	
Tips on Configuring A Modem.....	5-2
Configuring Ports: Web Interface .....	5-3
Configuring Incoming Modem Connections: Command Line .....	5-4
Configuring Outgoing and Bi-Directional Connections: Command Line .....	5-5
<b>Chapter 6 Configuring Ports for Terminals and Computers</b>	
Configuring Ports: Web Interface .....	6-2
Configuring Terminal Connections: Command Line .....	6-3
About Computer Connections.....	6-4
<b>Chapter 7 Configuring Autoconnection</b>	
About Autoconnection .....	7-2
Configuring a Port for Autoconnection: Web Interface.....	7-2
Configuring Autoconnection By Port: Command Line .....	7-2
Configuring a User for Autoconnection: Web Interface.....	7-3
Configuring a User for Autoconnection: Command Line .....	7-3

<b>Chapter 8 Configuring PPP</b>	
Configuring PPP Dial-In Connections .....	8-2
Configuring Dial-Out Connections .....	8-5
Introduction to Filters for PPP Connections .....	8-8
Filtering Examples .....	8-10
<b>Chapter 9 Configuring IP Routing</b>	
Introduction to Routing .....	9-2
About RIP Routing Updates .....	9-3
Configuring Static Routes .....	9-5
Configuring Dynamic Routes Using RIP.....	9-6
Configuring Proxy ARP.....	9-7
<b>Chapter 10 Configuring Console Management</b>	
About Console Management.....	10-2
Configuring Console Management: Web Interface .....	10-2
Configuring Console Management: Command Line .....	10-2
<b>Chapter 11 Configuring Modbus</b>	
About Modbus.....	11-2
Configuring Modbus Using the Web Interface .....	11-3
Configuring Modbus from the Command Line .....	11-4
Examples .....	11-6
<b>Chapter 12 Configuring Security Features</b>	
Controlling Access to the Digi One/PortServer TS 2/4 Configuration.....	12-2
Controlling Access to Inbound Ports .....	12-2
Controlling Access to Outbound Ports.....	12-3
Controlling Access to the Digi One/PortServer TS 2/4 Command Line .....	12-3
Issuing User Passwords.....	12-4
<b>Chapter 13 Configuring DNS</b>	
About the Domain Name System.....	13-2
Configuration Procedures .....	13-3
<b>Chapter 14 Configuring SNMP</b>	
About SNMP and the Digi One/PortServer TS 2/4 Agent.....	14-2
Configuration Procedure: Web Interface .....	14-3
Configuration Procedure: Command Line.....	14-3
<b>Chapter 15 Managing the OS and Configuration</b>	
Upgrading the OS (Firmware): Command Line .....	15-2
Configuring Digi One/PortServer TS 2/4 from a Remote Host.....	15-3
Resetting the Configuration to Defaults.....	15-5

## **Chapter 16 Configuration Examples**

Terminal Server Configuration Without RealPort .....	16-2
Terminal Server Configuration Using Autoconnection .....	16-3
Terminal Server Configuration Using RealPort .....	16-4
Dial-Out PPP Connection to a Host .....	16-5
Dial-Out PPP Network-to-Network Connection .....	16-7
PPP Dial-In Connection .....	16-9
Dial-In PPP Connection and Proxy ARP .....	16-10

## **Chapter 17 Digi One/PortServer TS 2/4 Troubleshooting**

Symptom: Digi One/PortServer TS 2/4 Does Not Boot .....	17-2
Symptom: Cannot Telnet to the Digi One/PortServer TS 2/4 .....	17-3
Symptom: Trouble Accessing a Port .....	17-4
Running Digi One/PortServer TS 2/4 Customer Diagnostics .....	17-4
Key to Interpreting Digi One/PortServer TS 2/4 LEDs .....	17-5
Verifying TFTP on a UNIX System .....	17-5
Troubleshooting TFTP Problems .....	17-5
Resetting Digi One/PortServer TS 2/4 Configuration to Defaults .....	17-6
Verifying the Digi One/PortServer TS 2/4 IP Address .....	17-7
Checking for Duplicate IP Addresses .....	17-7
Pinging an IP Address .....	17-7
Verifying the Network Cabling .....	17-8
Verifying the RealPort Process .....	17-9
Digi Contact Information .....	17-11



# About This Guide

## Purpose

This guide provides the following:

- Configuration and administration procedures
- Configuration examples

## Audience

This manual is intended for the person responsible for configuring and administering Digi One/PortServer TS 2/4. It assumes that this person has experience configuring network devices and is familiar with networking concepts.

## Scope

This manual provides step-by-step instructions for configuring and administering Digi One/PortServer TS 2/4's main features. It does not address how to configure every option, provide complete information on commands, or discuss hardware installation. These topics are covered in other documents in the Digi One/PortServer TS 2/4 library.

## About Command Line Examples

In this manual, many command examples are broken up and placed on two lines of the manual. This is done to control where the line breaks, making it as easy to read as possible. When this is done, the second line of the command will be indented slightly, as shown below.

```
set menu range=6 t1="Console Management Menu" name="Console Management
  Menu" m3="Connect to System 1" c3="connect 1" m4="Connect to System 2"
  c4="connect 2"
```

## About Entering Commands on the Command Line

On the Digi One/PortServer TS 2/4 command line, do not force a line break (by pressing Enter or Return). This will commit the command before you finish adding all command fields. If your terminal does not support wrapping to the next line and long commands scroll out of sight, the easiest way to enter long commands is by breaking the command into multiple commands as shown below. If you use this method, however, you must let the Digi One/PortServer TS 2/4 know that you are configuring the same entity, such as the same port, menu, or line. This is done by repeating the range or name field in each command.

```
set menu t1="Console Management Menu" range=6
set menu range=6 name="Console Management Menu" m3="Connect to System 1"
set menu range=6 c3="connect 1" m4="Connect to System 2"
set menu range=6 c4="connect 2"
```

## Supported Devices

This manual provides information on the following Digi devices:

- Digi One RealPort
- Digi One IA
- PortServer TS 2
- PortServer TS 4

## Configuring the IP Address

### *In This Chapter*

This chapter discusses how to configure Digi One/PortServer TS 2/4's IP address and other features associated with its Ethernet interface. It discusses the following topics:

- Options for Configuring the IP Address and Mask . . . . . 1-2
- Configuring an IP Address and Mask from the Command Line . . . . . 1-2
- Configuring an IP Address using DHCP and RARP. . . . . 1-2
- Configuring a Default Gateway . . . . . 1-3

## Options for Configuring the IP Address and Mask

The Digi One/PortServer TS 2/4 IP address and mask can be configured using the following methods:

- From the command line using the set config command
- Using a RARP server
- Using a DHCP server

The IP address and mask can also be changed using the web interface. This method, however, does not work for the initial IP address configuration.

## Configuring an IP Address and Mask from the Command Line

This section discusses how to assign an IP address and mask for Digi One/PortServer TS 2/4's Ethernet connection from the command line.

### Manual Configuration Procedure

1. To configure an IP address for the Ethernet interface, enter the following command:

```
set config ip=ip-address
```

where *ip-address* is the IP address for the Ethernet interface

Example: `set config ip=143.191.2.154`

2. To configure a subnetmask, enter the following command:

```
set config submask=mask
```

where *mask* is the subnet mask for this subnetwork

Example: `set config submask=255.255.255.0`

3. To ensure that this address is permanent, turn DHCP off by entering the following command:

```
set config dhcp=off
```

### Manual Configuration Example

In this example the set config command assigns an IP address and mask to the Digi One/PortServer TS 2/4 Ethernet connection.

```
set config ip=192.150.150.10 submask=255.255.255.0 dhcp=off
```

## Configuring an IP Address using DHCP and RARP

### About DHCP and RARP

When the Digi One/PortServer TS 2/4 boots, it transmits several DHCP requests. If no response is received, it transmits several RARP requests. This pattern is repeated until an address is assigned, either by one of these automatic methods or manually using the set config command.

### Procedure

To use RARP or DHCP follow these steps:

1. Set up an entry for an address on a DHCP or RARP server. If you intend to use RealPort, do the following:
  - Reserve a permanent IP address.
  - Record the IP address. You will need it when you configure the RealPort driver.
2. Power on the Digi One/PortServer TS 2/4.

The DHCP or RARP server assigns the Digi One/PortServer TS 2/4 an IP address.

## Configuring a Default Gateway

This section describes how to configure Digi One/PortServer TS 2/4 to use the services of a default gateway. A default gateway is a router to which stations on the LAN send datagrams destined for hosts to which they do not have routes.

### Procedure

To configure a default gateway, enter the following command:

```
set config gateway=ip-address
```

where *ip-address* is the IP address of the default gateway

### Example

```
set config gateway=191.143.2.46
```



***In This Chapter***

This chapter discusses how to configure users. It covers the following topics:

- About Configuring Users ..... 2-2
- Common User Features..... 2-2
- Configuring a User: Web Interface ..... 2-2
- Configuring a User: Command Line Examples ..... 2-4

## About Configuring Users

Although it is not required, the Digi One/PortServer TS 2/4 is often configured to accommodate the requirements of particular users. Typical configurable user attributes include the following:

- Whether the user is required to supply a password
- The times at which the user can access the device
- Autoconnection attributes, such as the system to which the user should be automatically connected at login
- The interface the device presents the user, such as a menu or command line
- Whether the user has access to outbound ports

**Note:** For information on configuring PPP users, see "Configuring PPP" on page 8-1.

## Configuration Methods

You can configure users in the following ways:

- With the set user command. See the set user command in the *Digi One/PortServer TS 2/4 Command Reference*.
- With the web interface.

## Common User Features

This section discusses common user-related features. For a complete list, see the set user command in the *Digi One/PortServer TS 2/4 Command Reference*.

Feature	Description	set user Field
autoconnect	Automatically connects the user to the host specified on the autohost field using the service (TCP port) defined on the autoport or autoservice fields. Autoconnection can also be implemented by port instead of by user. This feature is configurable from the web interface.	autoconnect autohost autoport autoservice
Default access type	Defines the type of access the user is restricted to. Menu, command line, autoconnect, and outgoing and netserviceare the types. This feature is configurable from the web interface.	defaultaccess
Menu access	Defines the menu that is to be presented to a user with menu access. This feature is configurable from the web interface.	menu
Port access	Defines the number of outbound ports a user connected over the LAN can access at one time. This feature is not configurable from the web interface.	maxsessions
PPP	Defines PPP-related parameters for the user.	There are too many fields to list here. See the set user command for more information.
Routing updates	Defines whether RIP routing updates are forwarded over the link to this user.	netrouting

## Configuring a User: Web Interface

1. Access the web interface by entering the Digi One/PortServer TS 2/4 IP address in a browser's URL window.
2. Log in to the Digi One/PortServer TS 2/4 as root.  
The default password is dbps.
3. Select Configure and then Users from the menu.
4. To add a user, do the following:
  - a. Choose Add User.
  - b. Enter a name and then choose Submit

- c. Choose the new user from the Name column.
  - d. Configure the user as required.
  - e. Choose Submit.
5. To return to the main User menu, choose User from the Menu again.

## Configuring a User: Command Line Examples

This section consists of a set of examples that tell you how to use the set user command to configure various user attributes.

### Configuring a User for a Password

In this example, the set user command configures a new user. The newpass command then initiates a dialog with the Digi One/PortServer TS 2/4 to assign a password to the new user.

```
set user name=jsmith
newpass name=jsmith
```

### Configuring a User for a Menu

In this example, the user is configured to use a menu, which is identified by a menu-table index number. If the menu has not been configured, the Digi One/PortServer TS 2/4 will generate a warning message, but the user will be configured to use the menu, which can then be created later.

```
set user name=jsmith defaultaccess=menu menu=4
```

### Configuring a User for Autoconnect

In this example, the user is configured to do the following

- Automatically connect to the host identified on the autohost field
- Connect using Telnet

```
set user name=jsmith autoconnect=on defaultaccess=autoconnect
autohost=191.143.2.17 autoservice=telnet
```

### Displaying an Entry in the User Table

This example assumes that the user named jsmith has already been created, in which case attributes for jsmith are displayed. If the user did not already exist, this command would create a new user named jsmith that uses all default attributes.

```
set user name=jsmith
```

### Removing a User from the User Table

In this example, a user, identified by a user table index number, is removed from the user table.

```
set user rmuser=on range=3
```

***In This Chapter***

This chapter describes how to configure Digi One/PortServer TS 2/4 for RealPort connections. It discusses the following topics:

- About RealPort. . . . . 3-2
- Configuring Ports: Web Interface . . . . . 3-3
- Configuring Ports for RealPort: Command Line . . . . . 3-4
- Example . . . . . 3-4

## About RealPort

This section provides a brief introduction to RealPort.

### What is RealPort?

RealPort is a feature that allows LAN-based host systems to use the ports of the Digi One/PortServer TS 2/4 as though they were the host system's own ports, appearing and behaving as local ports to the LAN-based host.

### RealPort Advantages

RealPort provides the following advantages:

- It expands the number of ports available to the host system.
- It enables Digi One/PortServer TS 2/4 ports to be treated as if they were directly connected to the host, which means they use all standard operating system interfaces that control baud rate, parity, stop bits, and flow control.
- It enables host administrators to do most of the required configuration on the host, the system with which the administrator is most familiar.
- It dramatically reduces host CPU overhead because multiple terminal or printer sessions are multiplexed over the same TCP/IP connection.

### Configuring the RealPort Software

You must install and configure RealPort software on each host that will use RealPort ports. See the RealPort documentation for more information.

### Configuration Options

You can configure Digi One/PortServer TS 2/4 for RealPort from the command line or using the web interface. For information on using the web interface, see "Configuring Ports: Web Interface" on page 3-3.

## Configuring Ports: Web Interface

Use this procedure to configure a port from the web interface.

1. Access the web interface by entering the Digi One/PortServer TS 2/4 IP address in a browser's URL window.
2. Log in to the Digi One/PortServer TS 2/4 as root.  
The default password is dbps.
3. Select Configure and then Ports from the menu.
4. To configure a port, do the following:
  - a. Choose the port from the port column.
  - b. Make changes to the configuration as required. Use the online help for information.
  - c. If you want to apply this configuration to multiple ports, choose Clone, select the ports for this configuration, and then choose Continue.
  - d. Choose Submit.
5. To return to the main Ports menu, choose Ports from the Menu again.

## Configuring Ports for RealPort: Command Line

This section describes how to configure RealPort ports from the command line.

### Procedure

Use this procedure to use the command line to configure Digi One/PortServer TS 2/4 for RealPort.

This procedure assumes that you have signed on as root and have or will

- Install RealPort software on each RealPort host. See the appropriate RealPort documentation for more information.
- Properly cabled Digi One/PortServer TS 2/4 ports and devices.
- Set up the devices connected to Digi One/PortServer TS 2/4 ports

1. Configure the RealPort TCP port by entering the following command:

```
set tcp realport=771
```

2. Configure Digi One/PortServer TS 2/4 ports by entering the following command:

```
set ports range=range dev=rp
```

where *range* is the range of ports to which this command applies

Example: `set ports range=2 dev=rp`

### Example

In this example, all ports are configured for RealPort.

```
set tcp realport=771
```

```
set ports range=* dev=rp
```

***In This Chapter***

This chapter describes how to configure Digi One/PortServer TS 2/4 ports for printer connections. It discusses the following topics:

- Configuration Considerations . . . . . 4-2
- Configuring Ports: Web Interface . . . . . 4-4
- Configuring Printer Connections: Command Line . . . . . 4-4
- Configuring a Port for Direct-Access Printing. . . . . 4-5

## Configuration Considerations

You should be aware of the following considerations if you intend to configure Digi One/PortServer TS 2/4 to handle printers.

### Using RealPort

RealPort, a feature that allows LAN-based host systems to use the ports of the Digi One/PortServer TS 2/4 as though they were the host system's own ports, is an easy and efficient way for printers to use Digi One/PortServer TS 2/4 ports. For information on this option, see "Configuring Ports for RealPort" on page 3-1.

### Determining Your Printer's Flow Control Requirements

If you set the Digi One/PortServer TS 2/4 flow control parameters incorrectly, the printer may not print all data sent to it. Consequently, before you configure a Digi One/PortServer TS 2/4 port for a printer, check the printer's documentation to determine if it uses hardware flow control, software flow control, or no flow control at all.

### Flow Control Tips

Here are some tips to ensure that your printer performs as expected:

- If flow control is necessary, ensure that the printer and Digi One/PortServer TS 2/4 use the same flow control scheme.
- Most printers that use hardware flow control issue the DTR (data terminal ready) signal when they are ready for data. If so, the DTR pin on the cable from the printer must be wired to an input on the Digi One/PortServer TS 2/4 port (usually CTS or DCD) that can be used for flow control.

### Printing with AIX Systems

Digi does not recommend using lpd to print multiple jobs to a Digi One/PortServer TS 2/4-attached printer from an AIX print spooler because this may cause the print job to time out.

### Using the lpd Protocol

Here are some tips for configuring the print spooler on your UNIX system when you intend to print using the lpd protocol to a printer attached to Digi One/PortServer TS 2/4:

1. The number of copies option with lpr is not supported.
2. Banner pages are not supported.
3. Give the Digi One/PortServer TS 2/4's DNS name or IP address as the remote system's name.
4. Specify a queue name that conforms to the following conventions:
  - Begin the queue name with one of the following character strings: (a) Use `ascii` if you want Digi One/PortServer TS 2/4 to substitute carriage return and line feed characters for each line feed the system sends. (b) Use `raw` if no substitution should be performed.
  - After the queue name, insert an underscore character and the number of the Digi One/PortServer TS 2/4 port to which the printer is attached.
  - If you want to use either of the following options, specify an additional underscore and then the letter that identifies the option: (a) Use `f` to append a form feed character to the end of each file in a print job (b) Use `d` to add a Ctrl-d to the end of each file in a print job. (This is often required by PostScript printers.)

#### Examples

String	Result
<code>ascii_1</code>	Prints to port 1 and translates CR to CR/LF.
<code>ascii_8_f</code>	Prints to port 8, translates CR to CR/LF and prints a form feed at the end of the job.
<code>raw_1_d</code>	Prints to port 1 with no translation and appends a Ctrl-d to the end of the print job.

## Tips for telnet and rsh Printing

Here are some tips for handling telnet and rsh printing:

- If line feed and carriage return problems occur, try supplying a set line command that specifies `onlcr=on`. This converts carriage returns to carriage return/line feeds.
- If you want tab characters (ASCII character 9) converted to 8 spaces, use a set line command that specifies `otab=on`.

## Configuring Ports: Web Interface

Use this procedure to configure a port from the web interface.

1. Access the web interface by entering the Digi One/PortServer TS 2/4 IP address in a browser's URL window.
2. Log in to the Digi One/PortServer TS 2/4 as root.  
The default password is dbps.
3. Select Configure and then Ports from the menu.
4. To configure a port, do the following:
  - a. Choose the port from the port column.
  - b. Make changes to the configuration as required. Use the online help for information.
  - c. If you want to apply this configuration to multiple ports, choose Clone, select the ports for this configuration, and then choose Continue.
  - d. Choose Submit.
5. To return to the main Ports menu, choose Ports from the Menu again.

## Configuring Printer Connections: Command Line

This section describes how to configure Digi One/PortServer TS 2/4 for printer connections.

### Related Information

See the set ports, set line, and set flow commands in the *Digi One/PortServer TS 2/4 Command Reference*.

### Procedure

This procedure assumes the following:

- That you are logged in as root
- That you know printer attributes, such as baud rate and parity

1. Configure the port for a printer by supplying the following command:

```
set ports dev=prn range=range
```

where *range* is a range of ports

Example: `set ports dev=prn range=1-2`

2. Configure line attributes with a set line command. The attributes you configure depend on printer requirements. See the set line command in the *Digi One/PortServer TS 2/4 Command Reference* to determine which set line command fields you require.
3. Configure flow control attributes with the set flow command. The attributes you configure depend on printer requirements. See the set flow command in the *Digi One/PortServer TS 2/4 Command Reference* for more information.

### Example

In this example, port 2 is configured for a printer that uses hardware flow control.

```
set ports range=2 dev=prn
```

```
set line range=2 baud=9600 csize=8 stopb=1 parity=n
```

```
set flow range=2 cts=on ixon=off ixoff=off
```

## Configuring a Port for Direct-Access Printing

Direct access printing allows Telnet users on the LAN to access a port and to issue print commands directly to the printer. This section describes the two ways users can access a printer directly and explains how to configure the port to support each method.

### Method 1: Specifying Port Numbers in the Telnet Command

This method allows users to issue telnet commands that identify the correct port by using TCP port numbers. Users identify the type of connection and port number by specifying one of the following:

For this connection type...	Identify the port by specifying...
Telnet	2000 plus the number of the port. <b>Example:</b> 2002 for port 2.
Raw	2100 plus the number of the port. <b>Example:</b> 2102 for port 2.

### User Command Example 1

In this example, a user specifies a standard telnet connection on port 2 of a Digi One/PortServer TS 2/4 using IP address 199.250.38.15.

```
cat myfile | telnet 199.250.38.15 2002
```

### User Command Example 2

In this example, a user specifies a raw telnet connection on port 2 of a Digi One/PortServer TS 2/4 using IP address 199.250.38.15.

```
cat myfile | telnet 199.250.38.15 2102
```

### Method 1 Configuration

There is no special configuration required to set up a port for this type of direct access. Simply configure the port for a printer. See "Configuring Printer Connections: Command Line" on page 4-4 for more information.

### Method 2: Using Alternate IP Addresses

This method provides similar functions to method 1, except alternate IP addresses allow users to identify a specific port by simply specifying an IP address.

### Method 2 Configuration

To configure an alternate IP address, do the following:

- Configure the port for a printer. See *Configuring Printer Connections: Command Line* on page 4-4 for more information.
- Supply a set altip command that specifies the following:

```
set altip group=port-number ip=ip-address
```

where

- *port-number* is the number of a Digi One/PortServer TS 2/4 port
- *ip-address* is the IP address of the Digi One/PortServer TS 2/4

### Example

```
set ports range=2 dev=prn
set line range=2 baud=9600 csize=8 stopb=1 parity=n
set flow range=2 cts=on rts=on ixon=off ixoff=off
set altip group=2 ip=199.250.38.17
```



***In This Chapter***

This chapter describes how to configure Digi One/PortServer TS 2/4 ports for modem connections. It discusses the following topics:

- Tips on Configuring A Modem ..... 5-2
- Configuring Ports: Web Interface ..... 5-3
- Configuring Incoming Modem Connections: Command Line ..... 5-4
- Configuring Outgoing and Bi-Directional Connections: Command Line .... 5-5

## Tips on Configuring A Modem

Here are some tips on configuring modems to work with Digi One/PortServer TS 2/4:

- Configure the modem so that DCD goes high when it receives an incoming connection request.
- Configure the modem to answer an incoming call only when DTR is high, and to drop the line when DTR goes low.
- For bidirectional connections, it is advisable to configure the non-volatile parameters in the modem for incoming calls. Also configure the modem to reset to these parameters when DTR is dropped.
- Configure the modem to lock the serial line speed at the highest baud rate the modem will accept for reliable data transfer because Digi One/PortServer TS 2/4 cannot switch the baud rate of the serial line on a per call basis without reconfiguration.

**Note:** You may want to consider connecting modems using RealPort, a feature that allows LAN-based host systems to use the ports of the Digi One/PortServer TS 2/4 as though they were the host system's own ports. It is an easy and efficient way for modems to use Digi One/PortServer TS 2/4 ports. For information on this option, see "Configuring Ports for RealPort" on page 3-1.

## Configuring Ports: Web Interface

Use this procedure to configure a port from the web interface.

1. Access the web interface by entering the Digi One/PortServer TS 2/4 IP address in a browser's URL window.
2. Log in to the Digi One/PortServer TS 2/4 as root.  
The default password is dbps.
3. Select Configure and then Ports from the menu.
4. To configure a port, do the following:
  - a. Choose the port from the port column.
  - b. Make changes to the configuration as required. Use the online help for information.
  - c. If you want to apply this configuration to multiple ports, choose Clone, select the ports for this configuration, and then choose Continue.
  - d. Choose Submit.
5. To return to the main Ports menu, choose Ports from the Menu again.

## Configuring Incoming Modem Connections: Command Line

This section describes how to configure incoming-only modem connections, that is, connections that are initiated by a device across the telephone network.

### Related Information

- If you intend to run PPP traffic over this modem connection, see "Configuring PPP" on page 8-1.
- For more information on setting the port's flow control attributes see the set flow command in the *Digi One/PortServer TS 2/4 Command Reference*.
- For information on setting up the port for autoconnection, see "Configuring Autoconnection" on page 7-1 of this manual and the set ports command in the *Digi One/PortServer TS 2/4 Command Reference*.
- For information on setting serial line operating parameters such as character size, the number of stop bits, and parity, see the set line command in the *Digi One/PortServer TS 2/4 Command Reference*.

### Procedure

This procedure assumes that you

- Know the operating parameters required by the modem. If you do not, see the modem documentation.
- Have or will correctly cable the connection between the Digi One/PortServer TS 2/4 serial ports and modems. See the *Digi One/PortServer Cable Guide* for more information.
- Have logged in as root

1. Supply a set ports command that specifies the following:

```
set ports range=range dev=min
```

where *range* is a Digi One/PortServer TS 2/4 port or range of ports.

Example: `set ports range=2 dev=min`

2. Supply a set line command that specifies the following:

```
set line range=range baud=bps
```

where *range* is a port or range of ports and *bps* is the line speed for this port.

Example: `set line range=2 baud=115200`

3. Supply a set flow command that defines the flow control scheme required by the modem.

## Example

In this example, ports 1 and 2 are set up for incoming modem connections using RTS/CTS flow control.

```
set ports range=1-2 dev=min
set line range=1-2 baud=115200
set flow range=1-2 ixon=off ixoff=off cts=on rts=on
```

## Configuring Outgoing and Bi-Directional Connections: Command Line

This section describes how to configure outgoing and bidirectional modem connections.

### Related Information

- For more information on setting the port's flow control attributes see the set flow command in the *Digi One/PortServer TS 2/4 Command Reference*.
- For information on setting up the port for autoconnection, see "Configuring Autoconnection" on page 7-1 and the set ports command in the *Digi One/PortServer TS 2/4 Command Reference*.
- For information on setting serial line operating parameters such as character size, the number of stop bits, and parity, see the set line command in the *Digi One/PortServer TS 2/4 Command Reference*.
- For more information on configuring dialer and login scripts, see the set script command in the *Digi One/PortServer TS 2/4 Command Reference*.

### Procedure

- If you intend to run PPP traffic over this modem connection, see "Configuring PPP" on page 8-1.

This procedure assumes that you

- Know the operating parameters required by the modem. If you do not, see the modem documentation.
- Have or will correctly cable the connection between the Digi One/PortServer TS 2/4 serial ports and modems. See the *Digi One/PortServer Cable Guide* for more information.
- Logged in as root

1. Supply a set ports command that specifies the following:

```
set ports range=range dev=dev
```

where *range* is a serial port or range of serial ports and *dev* is one of the following:

- dev=mout for outgoing-only connections
- dev=mio for bidirectional connections

**Note:** Use a group number (on the group field), if you intend to create a hunt group of ports that can access a pool of modems. Make sure this group number is greater than 65.

Example: `set ports range=2 dev=mio`

2. Supply a set line command that specifies the following:

```
set line range=range baud=bps
```

where *range* is a serial port or range of ports and *bps* is the line speed of the connection

Example: `set line range=2 baud=115200`

3. Supply a set flow command that defines the flow control scheme required by the modem.

## Example

In this example, ports 1 and 2 are configured for bidirectional modems.

```
set ports range=1-2 dev=mio
set line range=1-2 baud=115200
set flow range=1-2 ixon=off ixoff=off rts=on cts=on
```



## Chapter 6

# Configuring Ports for Terminals and Computers

### *In This Chapter*

This chapter describes how to configure Digi One/PortServer TS 2/4 ports for terminal and computer connections. It discusses the following topics:

- Configuring Ports: Web Interface ..... 6-2
- Configuring Terminal Connections: Command Line..... 6-3
- About Computer Connections ..... 6-4

## Configuring Ports: Web Interface

Use this procedure to configure a port from the web interface.

1. Access the web interface by entering the Digi One/PortServer TS 2/4 IP address in a browser's URL window.
2. Log in to the Digi One/PortServer TS 2/4 as root.  
The default password is dbps.
3. Select Configure and then Ports from the menu.
4. To configure a port, do the following:
  - a. Choose the port from the port column.
  - b. Make changes to the configuration as required. Use the online help for information.
  - c. If you want to apply this configuration to multiple ports, choose Clone, select the ports for this configuration, and then choose Continue.
  - d. Choose Submit.
5. To return to the main Ports menu, choose Ports from the Menu again.

## Configuring Terminal Connections: Command Line

This section describes how to configure Digi One/PortServer TS 2/4 ports for terminal connections.

### Port Defaults

Here is the default configuration for Digi One/PortServer TS 2/4 ports:

- VT-100 emulation
- 9600 baud
- 8-bit characters
- 1 stop bit
- No parity
- Software flow control

### Related Information

- For information on the set line, set ports, and set flow commands, see the *Digi One/PortServer TS 2/4 Command Reference*.
- For information on configuring terminal ports for autoconnections, see, "Configuring Autoconnection" on page 7-1.

### Procedure

This procedure assumes the following:

- That you are logged in as root
- That you know the attributes, such as baud rate and parity, of the terminal that will be connected to this port

1. Supply a set ports command that specifies the following:

```
set ports range=range dev=term sess=num-of-sess
```

where *range* is a port or range of ports and *num-of-sess* is the number of simultaneous sessions the port user can maintain

2. Supply a set line command that specifies the following:

```
set line range=range baud=bps csize=characters parity=parity  
stopb=num-bits
```

where

- *range* is a port or range of ports
  - *bps* is the line speed
  - *characters* is the character size
  - *parity* is the parity scheme to use on this line
  - *num-bits* is the number of stop bits to use
3. If your terminal uses hardware flow control, supply a set flow command that specifies the following (software flow control is the default, so a set flow command is not required in that case):

```
set flow range=range ixoff=off ixon=off cts=on rts=on
```

where *range* is a port or range of ports

**Note:** You may need to use additional set flow command fields, depending on the flow control scheme required by your terminal. See the set flow command in the *Digi One/PortServer TS 2/4 Command Reference* for more information.

### Example

In this example, port 1 and 2 are configured for connection to terminals using hardware flow control. The connection uses default for character size (8 bits), parity (no parity), and stop bits (1).

```
set ports range=1-2 sess=3 dev=term termttype=wy60
set line range=1-2 baud=19200
set flow range=1-2 ixon=off ixoff=off rts=on cts=on
```

## About Computer Connections

Configuring computer connections is very similar to configuring terminal connections, which is discussed on page 6-3. Consequently, this section simply discusses the differences between these connection types.

### Starting Point

This section assumes that

- You are logged in as root
- You know the attributes, such as baud rate and parity, of the PC that will be connected to this port

### Configuring Typical PC Connections

To configure a port for a directly-connected PC, where the PC always initiates the connection, configure the connection as you would a terminal connection, except on the set ports command do the following:

- Specify dev=min if you have a 10-pin null modem cable to support this type of connection.
- Specify dev=term if you do not have a 10-pin null modem cable

Consider defining the serial connection as a PPP link. See "Configuring PPP" on page 8-1 for more information.

#### Example

This example configures a directly-connected PC using PPP.

```
set ports range=4 dev=min
set line range=4 baud=19200
set flow range=4 ixon=off ixoff=off rts=on cts=on
set ippool count=2 ip=199.230.14.19
set user name=PPP1 protocol=ppp mtu=1500 ports=4 ipaddr=ippool ppp-
  auth=none
```

### Example

In this example, ports 1-2 are set up for a BBS host.

```
set ports range=1-2 dev=host group=70
set line range=1-2 baud=19200
set flow range=1-2 ixon=off ixoff=off rts=on cts=on
set altip group=70 ip=199.179.23.10
```

***In This Chapter***

This Chapter discusses how to configure the autoconnection feature. It covers the following topics:

- About Autoconnection . . . . . 7-2
- Configuring a Port for Autoconnection: Web Interface . . . . . 7-2
- Configuring Autoconnection By Port: Command Line . . . . . 7-2
- Configuring a User for Autoconnection: Web Interface . . . . . 7-3
- Configuring a User for Autoconnection: Command Line . . . . . 7-3

## About Autoconnection

The autoconnection feature allows you to configure a user to access the Digi One/PortServer TS 2/4 and then be automatically connected to a host on the LAN. You can implement autoconnection in the following ways:

- By port. In this case, all port users are automatically connected to the same host. The Digi One/PortServer TS 2/4 is completely transparent to them.
- By user. In this case, a user is required to login and may be required to supply a password, but once the user is authenticated, an automatic connection to a host is made.

## Configuring a Port for Autoconnection: Web Interface

1. Access the web interface by entering the Digi One/PortServer TS 2/4 IP address in a browser's URL window.
2. Log in to the Digi One/PortServer TS 2/4 as root.  
The default password is dbps.
3. Select Configure and then Autoconnect from the menu.
4. Configure the port as required. Use the online help for more information.
5. To return to the main Ports menu, choose Ports from the Menu again.

## Configuring Autoconnection By Port: Command Line

This section describes how to configure a port for autoconnection.

### Procedure

This procedure describes how to set up a port for autoconnection only. It assumes that you have or will configure the port appropriately for a modem connection (see Chapter 5) or terminal connection (see Chapter 6).

To configure a port to provide automatic connections for all port users, supply a set ports command that specifies the following:

```
set ports range=range auto=on dest=ip-address dport=tcp=port
```

where

- *range* is a port or range of ports
- *ip-address* is the IP address of the host to which the autoconnection should be made
- *tcp=port* is a TCP port to use for this connection

### Example

In this example, port 2 is configured for automatic Telnet connections to a host.

```
set ports range=2 auto=on dest=199.125.123.10 dev=min dport=23
```

## Configuring a User for Autoconnection: Web Interface

1. Access the web interface by entering the Digi One/PortServer TS 2/4 IP address in a browser's URL window.
2. Log in to the Digi One/PortServer TS 2/4 as root.  
The default password is dbps.
3. Select Configure and then Users from the menu.
4. To add an autoconnect user, do the following:
  - a. Choose Add User.
  - b. Enter a name and then choose Submit
  - c. Choose the new user from the Name column.
  - d. Configure the user. Be sure to specify the following: (1) Default Access: Autoconnect (2) Enable Autoconnect (3) The IP address that will be the destination for the autoconnect user (4) A Destination TCP port number, which determines the type of connection for this user (such as 23 for Telnet).
  - e. Choose Submit.
5. To return to the main User menu, choose User from the Menu again.

## Configuring a User for Autoconnection: Command Line

This section describes how to configure a user for autoconnection.

### Procedure

This procedure deals with autoconnection features only. It assumes that you have or will configure

- The port for modem connections (see Chapter 5) or terminal connections (see Chapter 6)
- Other user attributes (see the set user command in the *Digi One/PortServer TS 2/4 Command Reference*)

To configure a user to automatically connect to a host, supply a set user command that specifies the following:

```
set user name=user-name ports=ports autoconnect=on autohost=ip-address  
      autoport=tcp-port defaultaccess=autoconnect
```

where

- *user-name* is the name of the user
- *ports* is the ports this user can use
- *ip-address* is the IP address of the host to which the user will be connected
- *tcp-port* is the TCP port to use for connections

### Example

In this example, a user is configured for autoconnection using telnet to the host specified. Because the password field is not specified, the default (password=on) requires that the user supply a password before the connection is made.

```
set user name=user4 autoconnect=on autohost=199.193.150.10 autoport=23  
      defaultaccess=autoconnect
```



***In This Chapter***

This chapter discusses how to configure PPP connections and the filters that can be used to initialize and manage them. It covers the following topics:

- Configuring PPP Dial-In Connections . . . . . 8-2
- Configuring Dial-Out Connections . . . . . 8-5
- Introduction to Filters for PPP Connections . . . . . 8-8
- Filtering Criteria . . . . . 8-8
- Filtering Rules . . . . . 8-9
- Filtering Examples . . . . . 8-10

## Configuring PPP Dial-In Connections

This section discusses how to configure dial-in connections. It describes how to configure required attributes and common options. For information on fine-tuning PPP connections, see the description of the `set user` command in the *Digi One/PortServer TS 2/4 Command Reference*.

### Starting Point

This procedure assumes that you have logged in as root.

### Procedure

1. To configure the port for inbound calls, enter the following command:

```
set ports range=range dev=device
```

where *range* is the port or ports and *device* is an inbound device type. See the `set ports` command in the *Digi One/PortServer TS 2/4 Command Reference* for more information. For an inbound modem connection, use `dev=min`.

Example: `set ports range=3 device=min`

2. To configure flow control for the ports, enter the following command:

```
set flow range=range flow-control=scheme
```

where *range* is the port or ports and *flow-control=scheme* is the flow control required for this connection. Typically, for modem connections RTS and CTS are on.

Example: `set flow range=3 ixon=off ixoff=off rts=on cts=on`

3. To create a PPP user, enter the following command:

```
set user name=name protocol=ppp
```

where *name* is a name to assign the PPP user

Example: `set user name=pppin protocol=ppp`

4. To configure an IP address and mask for the remote PPP user, enter the following command:

```
set user name=name ipaddr=ip-address ipmask=mask
```

where

- *name* is the user's name
- *ip-address* is one of the following: (a) A standard IP address in dotted decimal format. (b) 0.0.0.0, which means the remote user will supply the IP address
- *mask* is the subnet mask to use for this PPP subnetwork

Example: `set user name=pppin ipaddr=199.1.1.1 ipmask=255.255.255.0`

5. To configure an IP address for the this end of the PPP connection, enter the following command:

```
set user name=name localipaddr=ip-address
```

where *name* is the user's name and *ip-address* is the IP address to assign to the Digi device's end of the PPP connection

Example: `set user name=pppin localipadr=199.1.1.2`

6. To specify a default service for this user, enter the following commands:

```
set user name=name defaultaccess=net-service net-service=on
```

where *name* is the name of the user

Example: `set user name=pppin defaultaccess=net-service net-service=on`

7. To configure the authentication on this PPP link, enter the following command:

```
set user name=name pppauth=auth-type
```

where *name* is the users name and *auth-type* is one of the following:

- none, if no authentication is required
- pap, if PAP authentication is required
- chap, if CHAP authentication is required
- both, if both PAP and CHAP authentication are required

Example: `set user name=pppin pppauth=both`

8. If you specified PAP authentication, enter the following command to supply a PAP user ID and password:

```
set user name=name papid=id pappasswr=password
```

where *name* is the user's name and *id* and *password* are the PAP ID and PAP password for this user

Example: `set user name=pppin papid=sammy pappasswr=buddy`

9. If you specified CHAP authentication, enter the following command to supply a CHAP ID and CHAP key:

```
set user name=name chapid=id chapkey=key
```

where *name* is the user's name and *id* and *key* are the CHAP ID and key for the user

Example: `set user name=pppin chapid=sammy chapkey=buddy`

10. If you specified both CHAP and PAP authentication, supply IDs and passwords for both PAP and CHAP. See the previous two steps and the following example:

Example

```
set user name=pppin papid=sammy pappasswr=buddy
```

```
set user name=pppin chapid=sammy chapkey=buddy
```

11. To implement address compression, enter the following command:

```
set user name=name addrcompress=on
```

12. To implement Van Jacobsen Header compression, enter the following command:

```
set user name=name compression=vj
```

13. To implement protocol compression, enter the following command:

```
set user name=name protoccompress=on
```

## Configuring Dial-In Connections: Example

This example shows a very simple PPP inbound configuration, a back-to-back PPP connection between two Digi One/PortServer TS 2/4 devices. Use it with the outbound example that follows later in this chapter to see how the configurations work together. Here are some points on this configuration:

- The port is set up for inbound connections (`dev=min`)
- Flow control is turned off on port 3. If a modem were configured, the flow control scheme required by the modem would be in use (probably RTS and CTS would be turned on)
- The IP address on the second set user command is the other side's Ethernet address. This could, however, be an IP address assigned to the PPP interface.
- Logins have been turned off on port 3. The set ports command at the end of the configuration uses a user-ID (`uid`), which is the index number in the user table for the user named `pppin`. Since logins are turned off, the Digi One/PortServer TS 2/4 uses this UID to determine how to communicate with the user accessing port 3.

```
set config ip=199.1.1.1 submask=255.255.255.0
```

```
set ports range=3 dev=min
```

```
set flow range=3 ixon=off ixoff=off
```

```
set user name=pppin protocol=ppp netservice=on defaultaccess=netservice
```

```
set user name=pppin ipaddr=143.191.3.100 ipmask=255.255.255.0 pppauth=none
```

```
set user name=pppin localipaddr=143.191.3.99
set logins range=3 login=off
set ports range=3 UID=3
```

## Configuring Dial-Out Connections

This section describes how to configure dial-out PPP connections. Use it to configure dial-out only connections or to configure the outbound portion of a bidirectional connection.

### Starting Point

This procedure assumes that you have logged in as root.

### Procedure

1. To configure the port for outbound calls, enter the following command:

```
set ports range=range dev=outbound-dev-type
```

where *range* is the port or ports and *outbound-dev-type* is one of the outbound device types. For outbound modem connections, use *dev=mout*. See the *set ports* command in the *Digi One/PortServer TS 2/4 Command Reference* for more information.

2. To configure flow control for the ports, enter the following command:

```
set flow range=range flow-control=scheme
```

where *range* is the port or ports and *flow-control=scheme* is the flow control required for this connection. Typically, for modem connections RTS and CTS are on.

Example: `set flow range=3 ixon=off ixoff=off rts=on cts=on`

3. To create a dialer script for this outbound connection, enter the following command

```
set script name=name s#="script"
```

where:

- *name* is a name for the script
- *#* is the stanza number
- *script* is the dialer script

Example: `set script name=dialer s1="M{\r}P2 G+"`

See the *set script* command in the *Digi One/PortServer TS 2/4 Command Reference*.

4. To create an outbound device for this PPP user, enter the following command:

```
set device name=name ports=ports dialer=name
```

where

- *name=name* is the name for this device
- *ports* are the ports to associate with this device
- *dialer=name* is the name of the dialer script that was just created

Example: `set device name=dialout dialer=dialer ports=3`

5. To create a PPP user, enter the following command:

```
set user name=name protocol=ppp defaultaccess=netSERVICE netSERVICE=on
```

where *name* is the name of the PPP user

Example

```
set user name=pppout protocol=ppp defaultaccess=netSERVICE netSERVICE=on
```

6. To configure this user for outbound connections, enter the following command:

```
set user name=name dialout=on outgoing=on
```

Example: `set user name=pppout dialout=on outgoing=on`

7. To supply an IP address and mask to this same user, enter the following command:

```
set user name=name ipaddr=ip-address ipmask=mask
```

where

- *name* is the name of the remote PPP user
- *ip-address* is one of the following: (a) A standard IP address in dotted decimal format. (b) 0.0.0.0, which means the remote user will supply the IP address
- *mask* is the subnet mask to use for this PPP subnetwork

Example: `set user name=pppout ipaddr=192.1.2.3 ipmask=255.255.255.0`

8. To configure an IP address for the this end of the PPP connection, enter the following command:

```
set user name=name localipaddr=ip-address
```

where *name* is the user's name and *ip-address* is the IP address to assign to the Digi device's end of the PPP connection

Example: `set user name=pppout localipadr=199.1.1.2`

9. To configure authentication on this PPP link, enter the following command:

```
set user name=name pppauth=auth-type
```

where *name* is the user's name and *auth-type* is one of the following:

- none, if no authentication is required
- pap, if PAP authentication is required
- chap, if CHAP authentication is required
- both, if both PAP and CHAP authentication is required

Example: `set user name=pppout pppauth=both`

10. If you specified PAP authentication, enter the following command to supply a PAP user ID and password:

```
set user name=name papid=id pappasswr=password
```

where *name* is the user's name and *id* and *password* are the PAP ID and PAP password for this user

Example: `set user name=pppout papid=sammy pappasswr=buddy`

11. If you specified CHAP authentication, enter the following command to supply a CHAP ID and CHAP key:

```
set user name=name chapid=id chapkey=key
```

where *name* is the user's name and *id* and *key* are the CHAP ID and key

Example: `set user name=pppout chapid=sammy chapkey=buddy`

12. If you specified both CHAP and PAP authentication, supply IDs and passwords for both PAP and CHAP. See the previous two steps and the following example.

Example:

```
set user name=pppout papid=sammy pappasswr=buddy
```

```
set user name=pppout chapid=sammy chapkey=buddy
```

13. To implement address compression, enter the following command

```
set user name=name addrcompress=on
```

14. To implement Van Jacobsen Header compression, enter the following command:

```
set user name=name compression=vj
```

15. To implement protocol compression, enter the following command:

```
set user name=name protoccompress=on
```

## Configuration Example

This example shows a very simple PPP outbound configuration, a back-to-back PPP connection between two Digi One/PortServer TS 2/4 devices. Use it with the inbound example that appears earlier in this chapter to see how the configurations work together. Here are some points on this configuration:

- The port is set up for outbound connections (dev=mout).
- Flow control is turned off on port 3. If a modem were configured, the flow control scheme required by the modem would be in use (probably RTS and CTS would be turned on).
- A dialer script is defined with a set script command.
- A dialer device is defined with the set device command. The dialer field on this command references the dialer script created with the set script command.
- The IP address on the third set user command is the other side's Ethernet address. This could, however, be an IP address assigned to the PPP interface.
- The last set user command references the dialer device on the device field.

```
set config ip=143.191.3.100 submask=255.255.224.0
set ports dev=mout range=3
set flow range=3 ixoff=off ixon=off
set script name=dialer s1=M{\r}P2 G+
set device name=dialout dialer=dialer ports=3
set user name=pppout protocol=ppp pppauth=none dialout=on outgoing=on
set user name=pppout defaultaccess=netSERVICE netSERVICE=on
set user name=pppout ipaddr=199.1.1.1 ipmask=255.255.255.0
set user name=pppout localipaddr=199.1.1.2
set user name=pppout device=dialout dialout=on
```

# Introduction to Filters for PPP Connections

## Purpose

Filters are used to manage and control PPP connections. You can design a filter to do any of the following:

- Bring up a connection
- Allow certain types of packets to use the connection and keep certain types of packets from using it
- Keep a connection up
- Send a message to the log file when a specified event occurs on the connection

## Example

You might, for example, develop a filter that brings up a connection on an outbound port only when Digi One/PortServer TS 2/4 handles a packet carrying a particular destination IP address.

## How a Filter Functions

Fields on the set user command define how a filter functions, that is, whether it is the type of filter that accepts or blocks packets, brings up a connection, keeps up a connection, or sends a message to the log file. The following table describes each of the set user command fields related to filtering.

set user Field	Description	Example
passpacket	Causes a packet to be passed or blocked	Filter causes incoming packets from an IP address to be accepted and packets from all other IP addresses to be blocked
keepup	Causes the idletimeout timer to be reset and a connection maintained.	Filter that causes the connection to be maintained as long as there is any packet traffic except RIP packets.
bringup	Causes the Digi device to establish a connection.	Filter that causes an outgoing connection to be initiated whenever a packet specifying a particular IP address is handled
logpacket	Causes the Digi device to send a message to the log file	Filter that notifies the log anytime an ICMP packet is handled

## What Filters Contain

Filters contain filtering criteria. That is, they specify the attributes of the packet upon which the filter will make decisions (whether to pass a packet or block it, whether to bring up a connection or not, etc.) Examples include IP addresses and whether the packet carries ICMP messages.

## Filtering Criteria

You can filter on the following elements in a packet:

- A name of a service (defined in the service table) that identifies a particular type of packet.
- The name of a host defined in the host table
- The number in an IP packet that identifies the protocol to which IP should pass the packet. Use one of the following: 1 for ICMP, 2 for IGMP, 6 for TCP, and 17 for UDP.
- An IP address or set of addresses
- TCP or UDP port numbers
- Incoming or outgoing packets
- Source or destination criteria, such as IP addresses, ports, and host names
- When the start of a TCP data stream is encountered. This option is always used with the fin option and is used to trigger logging (logpacket field on the set user command).
- TCP or UDP packets
- ICMP packets, which can be broken down further into the following types of ICMP packets:

Packet Type	Type Identifier
Echo reply	0

Destination unreachable	3
Source quench	4
Redirect	5
Echo request	8
Time exceeded for a datagram	11
Parameter problem on a datagram	12
Timestamp request	13
Timestamp reply	14
Address mask request	17
Address mask reply	18

- ! (exclamation), which means that if filter criteria is met, the action normally performed by this type of filter should **not** be performed.

## Filtering Rules

Here are a list of rules for creating filters:

- Filters are made up of 1 to 32 stanzas, each of which expresses filtering criteria.
- Stanzas are processed in order. That is, first S1 (stanza 1) is processed and then S2, and so on.
- As soon as a stanza's criteria is completely satisfied, filtering action occurs and subsequent stanzas are ignored. For example, if S1 specifies an IP address of 190.159.146.10 and an ICMP message type 7, a packet from that IP address carrying that ICMP message type will trigger filtering action. Subsequent stanzas will not be processed. Consequently, you must specify and relationships (all criteria must be satisfied) in the same stanza and or relationships (any of the criterion must be satisfied) in different stanzas.
- The exclamation mark (!) at the beginning of a stanza changes how the filter acts. When a packet is encountered that meets stanza criteria, the filter does **not** execute the filter function (for example, bringing up a connection).

## Filtering Examples

This section provides examples of filters and the set user commands that define what type of actions the filters take when filter criteria is met.

### Note on the Examples

The set user commands in these examples are **not** sufficient to fully define a user for a PPP connection. They have been simplified to illustrate the relationship between the set filter and set user commands.

### Record ICMP Events in the Log File

In this example, a message is sent to the log file anytime Digi One/PortServer TS 2/4 handles an ICMP message.

- The set filter command defines a filter that uses ICMP messages as filtering criteria.
- The set user command references the filter on the name field and defines the filter as one that records ICMP activity in the log file.

```
set filter name=filter1 s1=icmp
set user name=tonik logpacket=filter1
```

### Open a Connection for Certain IP Addresses

In this example, Digi One/PortServer TS 2/4 opens a connection whenever it handles packets destined for any of the IP addresses specified. Note that the set filter command specifies an or relationship. That is, a packet with a destination IP address that matches any of those listed will open a connection. Had these addresses been listed in the same stanza, an and relationship would have been specified, meaning a packet would have had to specify all of these IP addresses in the destination IP address field. Since this is not possible, a connection would never be opened.

```
set filter name=filter1 s1=dst/199.86.8.22 s2=dst/199.86.8.27
set filter name=filter1 s3=dst/199.86.8.54
set user name=garyg ipaddr=199.86.8.22 bringup=filter1
set user name=dant ipaddr=199.86.8.27 bringup=filter1
set user name=ronk ipaddr=199.86.8.54 bringup=filter1
```

### Blocking Calls To a Subnet

In this example, Digi One/PortServer TS 2/4 blocks all calls to the subnet specified.

- The set user command defines this as the type of filter that allows packets to pass over the connection when they meet filtering criteria.
- The set filter command uses the exclamation point (!) to indicate that the normal filtering action for this type of filter should **not** occur.

```
set filter name=filter1 range=2-3 s1=!199.86.8.27 mask=255.255.255.0
set user name=router1 passpacket=filter1
```

### Filtering on Destination TCP Ports

In this example, Digi One/PortServer TS 2/4 brings up a connection when the destination TCP port is within the range specified.

```
set filter name=filter-port range=2 s1=tcp/20-25/dst
set user name=user1 bringup=filter-port
```

***In This Chapter***

This chapter describes how to configure IP routing. It discusses the following topics:

- Introduction to Routing . . . . . 9-2
- About RIP Routing Updates. . . . . 9-3
- Configuring Static Routes . . . . . 9-5
- Configuring Dynamic Routes Using RIP. . . . . 9-6
- Configuring Proxy ARP. . . . . 9-7

# Introduction to Routing

This section provides some introductory information on routing.

## What is Routing

Routing is the method, employed by IP software, of choosing a path over which to send packets between systems on different physical networks. When Digi One/PortServer TS 2/4 is configured as a router, it performs this service.

## Types of Routing

Digi One/PortServer TS 2/4 can be configured to perform the following types of routing:

- **Static routing.** When you use static routing, you manually configure routes to other networks for Digi One/PortServer TS 2/4. Static routing works fine for small, stable networks. Maintaining static routes is difficult on larger networks and on networks that experience a lot of changes.
- **Dynamic routing.** When you use dynamic routing, routes are not manually configured but are automatically established and maintained using information provided by routing information protocol (RIP). Route maintenance is obviously easier using RIP, but RIP has some shortcomings that are discussed later in this chapter.
- **Proxy ARP,** which is a technique in which a router answers ARP requests intended for another system. Typically, you use proxy ARP to move packets between physical networks that use the same IP network address. By pretending to be the other system, the Digi One/PortServer TS 2/4 accepts responsibility for forwarding packets to that system. Proxy ARP makes routing decisions based on either static routes or on routing information provided by RIP.

# About RIP Routing Updates

## Introduction

RIP defines a method for propagating routing information among routers. It provides IP software with the information needed to make intelligent routing decisions.

The information, passed in RIP updates packets from router-to-router, consists of two items, a network ID and a hop count. A hop count is the number of routers through which a packet must pass on its way from a source to a destination network.

## RIP Example

In the example that follows, Router R1 “advertises” (using RIP) that it can reach Net 1 in one hop. When Router R2 receives this advertisement, it then knows that since it is on a common network with R1 that it can reach Net 1 in two hops. It advertises this fact to other routers in the network, who use this information to calculate their own routes to Net 1.

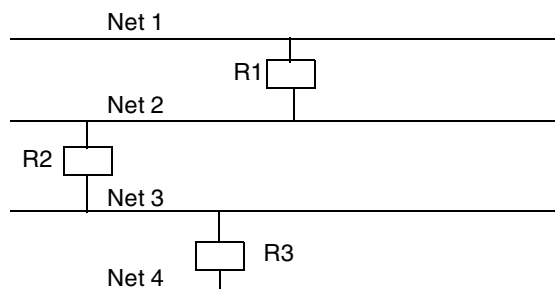

## Problem with RIP: Sending Updates Across a WAN

RIP can be an expensive way to handle routing if RIP updates are regularly sent across lines that charge by traffic volume or usage time. Neither of these, of course, applies to LANs or leased lines. Because of these cost considerations, Digi One/PortServer TS 2/4 lets you turn RIP off on some or all serial links.

## Problem with RIP: Slow Convergence

Slow convergence is a problem that can arise from the method RIP uses to disseminate routing information. In the preceding figure,

1. R1 advertises that it can reach Net 1 in one hop.
2. R2 then advertises that it can reach Net 1 in two hops
3. R3 then advertises that it can reach Net 1 in three hops.

What happens if R1’s link to Net 1 goes down? First it realizes that its one-hop route to Net 1 is no longer available. But it hears that R2 can reach Net 1 in two hops, so it updates its routing table to say it can reach Net 1 in three hops, the one hop to R2 and the two hops R2 says it needs to reach Net 1.

R1 then advertises that it can reach Net 1 in three hops. R2 hears the advertisement and realizes that if R1 needs three hops to get to Net 1 then it needs to update its own routing tables to reflect that fact, because it knows that its route to Net 1 is always one more hop than R1 requires. Consequently, it updates its routing tables to say that it can reach Net 1 in four hops. This can go on until the hop count to Net 1 reaches 16, which RIP defines as an unreachable destination.

## Combating RIP’s Slow Convergence Problem

There are two methods to combat RIP’s slow convergence problem, both of which Digi One/PortServer TS 2/4 implements.

The first is called “split horizon,” which stipulates that learned routes are **not** propagated from the interface on which they are learned. Had split horizon been used in the preceding example, R2 would not have advertised to R1 that it could reach Net 1. Consequently, R1 would never have

regarded R2 as an alternate path to Net 1.

The second is called “poison reverse,” which stipulates that routes are advertised as unreachable on the interface on which the route is learned. Had poison reverse been used in the preceding example, R2 would have advertised Net 1 as unreachable in its RIP updates to R1. Again R1 would never have regarded R2 as an alternate path to Net 1.

### **Digi One/PortServer TS 2/4 Participation in RIP Updates**

Digi One/PortServer TS 2/4's participation in the exchange of RIP updates can be configured on the set forwarding command. This command allows you to configure Digi One/PortServer TS 2/4

- To neither receive nor propagate RIP updates (state=off), which means it must be configured for static routes (set route command) if it is to do any routing at all.
- To receive RIP updates but not advertise its own routes using RIP (state=passive)
- To both receive and pass RIP updates (state=active)

## Configuring Static Routes

This section describes how to configure Digi One/PortServer TS 2/4 for static routes.

### Related Information

See the set route command in the *Digi One/PortServer TS 2/4 Command Reference*.

### Starting Point

This procedure assumes that you have or will configure modems, modem scripts, devices, and filters for routes that use serial lines.

### Procedure

1. Configure the links over which routing and RIP updates will be sent.
2. Configure a static route to every destination to which you want Digi One/PortServer TS 2/4 to route packets. Specify the following on the set route command:
  - The IP address and mask of the destination network on the net and mask fields
  - The number of hops to the destination network (on the metric field)
  - One of the following:
    - If the path to the destination network is across the LAN, specify the IP address of the router that is the next hop to the destination network (on the gateway field)
    - If the path to the destination network is through a serial port, specify the name of the set user command that defines the PPP connection (on the wanname field)

### Example: Static Routes

In this example, which shows only those commands and command fields pertinent to routing, Digi One/PortServer TS 2/4 is configured for two static routes.

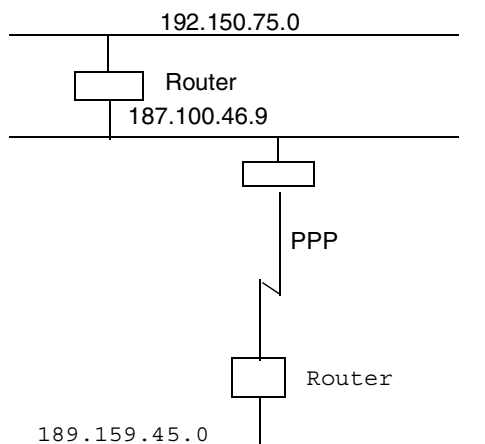

```
set route net=192.150.75.0 mask=255.255.255.0 gateway=187.100.46.9 metric=1
set route net=189.159.45.0 wanname=link1 metric=1
set user name=link1...
```

# Configuring Dynamic Routes Using RIP

This section describes how to configure Digi One/PortServer TS 2/4 for dynamic routing.

## Related Information

See the set forwarding command in the *Digi One/PortServer TS 2/4 Command Reference*.

## Starting Point

This procedure assumes that you have sign on as root and have or will configure modems, modem scripts, devices, and filters for routes that use serial lines.

## Procedure

1. Configure the links over which routed packets and RIP updates will be sent.
  - To enable routing over the LAN to which Digi One/PortServer TS 2/4 is attached, no routing-specific configuration is required.
  - To enable routing over PPP, links be sure to use the netrouting field on the set user command to configure how Digi One/PortServer TS 2/4 handles RIP updates. You can configure the link so that Digi One/PortServer TS 2/4 does any of the following with RIP updates:
    - Both sends and receives them (netrouting=both)
    - Sends them only (netrouting=send)
    - Receives them only (netrouting=receive)
    - Neither sends nor receives them (netrouting=off)
2. Configure the Digi One/PortServer TS 2/4 for dynamic routing with a set forwarding command that specifies state=active.

You may also want to turn on the poisonreverse and splithorizon fields to prevent the RIP slow convergence problem discussed on page 9-3. See the discussion on the set forwarding command provided in the *Digi One/PortServer TS 2/4 Command Reference* for more information.

### Example: Dynamic Routes

In this example, which shows only those commands and command fields pertinent to routing, Digi One/PortServer TS 2/4 is configured for dynamic routing using RIP. But to prevent RIP updates from being sent across the PPP link, the set user command that defines the link specifies netrouting=off.

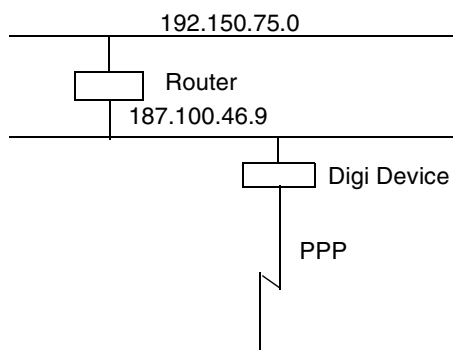

```
set forwarding state=active poisonreverse=on splithorizon=on
set user name=link1...netrouting=off
```

## Configuring Proxy ARP

This section describes how to configure Digi One/PortServer TS 2/4 for Proxy ARP.

### Related Information

See the set forwarding command in the *Digi One/PortServer TS 2/4 Command Reference*.

### Starting Point

This procedure assumes that you have signed on as root and have or will configure modems, modem scripts, devices, and filters for routes that use serial lines.

### Procedure

1. Configure the links over which packets will be routed using a set user command. This command must specify (on the ipaddr field) a specific IP address for the remote system using the Proxy ARP service.
2. Configure Digi One/PortServer TS 2/4 for Proxy ARP by supplying a set forwarding command that specifies the following:
  - state=passive
  - proxyarp=on

### Example

In this example, Digi One/PortServer TS 2/4 provides Proxy ARP services to a remote host.

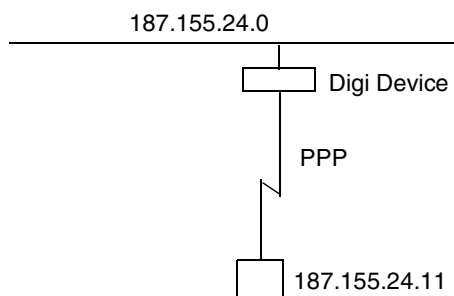

```
set user name=link1...ipaddr=187.155.24.11
set forwarding state=passive proxyarp=on
```



***In This Chapter***

- About Console Management . . . . . 10-2
- Configuring Console Management: Web Interface . . . . . 10-2
- Configuring Console Management: Command Line . . . . . 10-2

## About Console Management

PortServer TS 8/16 can be configured to remotely manage network devices, such as routers, switches, and servers, which usually provide EIA-232 serial ports for management. Using the PortServer TS 8/16 and TCP/IP utilities like reverse Telnet and SSH2, network administrators can access consoled serial ports from a single station over the LAN.

## Configuring Console Management: Web Interface

1. Access the web interface by entering the PortServer TS 8/16 IP address in a browser's URL window.
2. Log in to the PortServer TS 8/16 as root.  
The default password is dbps.
3. Select Configure and then Console Management from from the menu.
4. Follow the prompts to complete configuration.

## Configuring Console Management: Command Line

This procedure describes how to configure PortServer TS 8/16 to handle console management.

### Procedure

1. For each port connected to a device that will be managed, specify the following:  

```
set ports dev=prn range=range
```

where *range* is the port or range of ports to be set up for console management
2. Ensure that the port and the device to be managed are using the same flow control scheme.
  - See the device's documentation for information on flow control requirements.
  - To check the PortServer TS 8/16 current settings and to change them, see description of the set flow command in the *PortServer TS 8/16 Command Reference*.
3. Ensure that the port and the device are using the same baud rate.
  - See the device's documentation for information on baud rate requirements.
  - To check the PortServer TS 8/16 current settings and to change them, see set line description in the *PortServer TS 8/16 Command Reference*.
4. If you want to simplify access to the ports, do one of the following:
  - If the administrator will access the port from a station on the LAN, you can assign IP addresses to each port that will be connected to a managed device, which will allow the administrator to to Telnet directly to the port without specifying a port number. See set altip command in the *PortServer TS 8/16 Command Reference* for more information.
  - If you want to use a menu to simplify access, see the examples that follow and the set menu command in the *PortServer TS 8/16 Command Reference* for more information.
5. If you want to use SSH2 connections, do one of the following:
  - To simply use a password for SSH2 connections, go to the next step.
  - To use a public key for authentication, (available on PortServer TS 4 devices only), enter the following command:

```
set user name=name loadkey=host:key
```

where

- *name* is the name of a user who will be able to access the Digi device using SSH
- *host* is the IP address or DNS name of a host that will download an SSH2 public key to the Digi device.
- *key* is is the name of a host file in SECSH format, which contains the SSH2 public key. If your host's implementation requires a complete path to the file, specify the path here as well.

## Example: SSH2 and Menu Access

In this example, a Digi device is configured to use an SSH2 public key, and it presents a menu to the administrator, from which he or she will select a device to manage. The SSH feature is only available on PortServer TS 4 device. The rest of the configuration works for all Digi devices.

Key aspects of this configuration include the following:

- Two ports to which the managed devices are connected specify dev=prn, a device type that does not spawn a login from the Digi device.
- A menu specifies connect commands, which when selected provide connections to ports 1 and 2 and the managed systems. The menu also specifies a menu table index number of 6 (on the range parameter), which is then linked to a user with the set user command

```
set ports dev=prn range=1-2
set line baud=19200 range=1-2
set menu t1="Console Management Menu" range=6
set menu range=6 name="Console Management Menu" m3="Connect to System 1"
set menu range=6 c3="connect 1" m4="Connect to System 2"
set menu range=6 c4="connect 2"
set user name=admin1 defaultaccess=menu menu=6 password=on outgoing=on
set user name=admin1 loadkey=142.191.2.34:ssh-file1
```

## Example: Alternate IP Addresses

In this example, the PortServer TS 8/16 is configured with alternate IP addresses with set altip commands, which assign IP addresses to ports 1 and 2. This enables direct access to one of these ports with a Telnet command that specifies one of the IP addresses.

```
set ports dev=prn range=1-2
set line baud=19200 range=1-2
set altip group=1 ip=119.180.33.50
set altip group=2 ip=119.180.33.51
```



***In This Chapter***

- About Modbus ..... 11-2
- Configuring Modbus Using the Web Interface ..... 11-3
- Configuring Modbus from the Command Line ..... 11-4
- Examples ..... 11-6

# About Modbus

## What Is Modbus

Modbus is a protocol that defines a method for devices in an industrial automation environment to communicate. It allows a single controlling unit, called a protocol master, to manage one or more units, called protocol slaves. The protocol specifies that only the master may initiate communication. Slaves may only respond.

The protocol defines the structure of Modbus messages, determines how the master requests information from the slave or specifies an action for the slave to take, defines how the slave is to respond, specifies addressing conventions, and deals with many of the other details required for communication to occur.

## Modbus and Modbus TCP

There are two forms of the protocol. Modbus, the older of the two, was designed to run over serial connections, such as RS-232 links, and designed to use one of two encoding schemes, ASCII or RTU.

Modbus TCP is simply an adaptation of Modbus that provides for Modbus message encapsulation within IP datagrams, enabling Modbus messages to run over TCP/IP networks.

## Digi's Support for Modbus and Modbus TCP

Digi provides an extremely flexible implementation, offering support for Modbus TCP, Modbus with RTU encoding, and Modbus with ASCII encoding. The implementation allows any combination of these transport mechanisms.

Here are some examples of the configurations supported:

- A master (or multiple masters) using Modbus TCP communicates through the Digi device with a port-attached slave or group of slaves using Modbus RTU. A similar configuration allows the master to use Modbus TCP to communicate with a port-attached slave using Modbus ASCII.
- A port-connected master using Modbus RTU communicates with multiple network-connected slaves, each using Modbus TCP.

## Configuration Methods

Modbus can be configured using the web interface or the command line. The web interface is extremely easy to use and works for many configurations. More complex configurations may require the flexibility provided by the command line interface.

## Key Modbus Configuration Considerations

A key to ensuring that your Modbus configuration works as intended is matching masters with the slaves they control. So, here are some things to keep in mind:

- The default configuration allows any Modbus TCP master to communicate with any port-attached slave using RTU encoding. Consequently, if there are no security considerations, that is, if you are not concerned about restricting access to slaves to particular masters, and the slaves use RTU encoding, no Modbus configuration is required. (There are still, however, some non-Modbus configuration tasks that must be completed, such as assigning the Digi device an IP address and configuring ports.)
- If you use the command line, you must match masters to slaves in the following way:
  - The set modbus slave command has a range field that requires you to assign an index number to identify the slave.
  - The set modbus master command has a slave field that requires you to list the index numbers of slaves that are to be controlled by that master. The examples that follow will clarify this relationship.

## Configuring Modbus Using the Web Interface

1. Access the Digi One/PortServer TS 2/4 from a web browser by entering the Digi One/PortServer TS 2/4 IP address in the URL window.
2. Sign on to the Digi One/PortServer TS 2/4.
3. Choose Modbus from the menu.
4. Fill in fields as required. Use the context-sensitive help for guidance.
5. Configure ports for modbus, by doing the following:
  - a. Select Ports.
  - b. Specify Modbus as the device type.
  - c. Configure other port attributes as required by the attached device.
6. Exit to the main menu when you finish.

# Configuring Modbus from the Command Line

Use this procedure to configure a Digi device for Modbus.

## Starting Point

This procedure assumes that you have logged on to the Digi device as root.

## Procedure

1. To ensure that the line speed for the port is configured to match the speed required by the attached device, issue the following command:

```
set line range=range baud=bps csize={5|6|7|8} parity={o|e|n}
    stopb={1|2}
```

where

- *range* is a port or ports
- *bps* is the line speed required
- *csize* is the character size, 5, 6, 7, or 8 bits
- *parity* is odd (o), even (e), or none (n)

2. Configure the port for Modbus by specifying the following command:

```
set ports range=range dev=modbus
```

where *range* is a port or ports

3. Configure a Modbus master by issuing a set modbus master command that specifies the following:

- An index number on the range field to identify this master or set of masters. Use an integer between 1 and 16. Example: `range=3`
- If the master or masters are located on the network, an IP address or range of IP addresses  
Example of single IP address: `ip=143.191.3.117`  
Example of a range of addresses: `ip=143.191.3.117-143.191.3.122`
- If the master or masters are connected to a port or range of ports, a port number or numbers on the port field:  
Example of a single port: `port=1`  
Example of range of ports: `ports=1-2`
- The index number of the slave or slaves that this master will control on the slaves field.  
Example of a single slave: `slave=17`  
Example of a range of slaves: `slave=17-22`
- If this master is connected to a serial port, an encoding scheme (ASCII or RTU) on the format field. Specify the encoding scheme required by the master.  
Example: `format=ascii`
- Timers as required. Typically the defaults work. If you require additional information, see the set modbus command in the *Digi One/PortServer TS 2/4 Command Reference*.

4. Configure the Modbus slave by issuing a set modbus slave command that specifies the following:

- An index number on the range field to identify this slave. Use an integer between 1 and 32. This number must be included in the range of slave index numbers specified on the slave field of the set modbus master command.  
Example: `range=15`
- If this slave is located on the network, an IP address  
Example: `ip=143.191.3.117`
- If this slave is connected to a port, a port number on the port field:  
Example: `port=1`
- If this slave is connected to a serial port, an encoding scheme (ASCII or RTU) on the format field. Specify the encoding scheme required by the slave.  
Example: `format=ascii`

- A Modbus protocol unit number for each slave. This can be specified in any of the following ways: (a) An individual unit number. (b) A range of unit numbers. (c) All, which means accept messages carrying any Modbus protocol unit number.
- Timers as required. Typically the defaults work. If you require additional information, see the set modbus command in the *Digi One/PortServer TS 2/4 Command Reference*.

# Examples

## Configuring Network-Connected Masters

### *Introduction*

Here are a few points regarding this configuration:

- All timers for both masters and slaves are using defaults.
- The range field on the set modbus master command is an index number that Digi One IA identifies these masters. The range fields on each of the set modbus slave commands identify the individual slaves.
- The slaves field on the set modbus master command then identifies the slaves that belong to this master.
- The value on the unit fields of the set modbus slave commands are hardware addresses for the slaves.
- The format=rtu option on the set modbus slave command is optional, since rtu is the default for Modbus communication over the serial port.

### *Configuration*

```
set line range=1 baud=14400
set ports range=1 dev=modbus
set modbus master range=1 ip=143.191.2.100-143.191.2.102 slaves=2-3
set modbus slave range=2 port=1 format=rtu unit=100
set modbus slave range=3 port=1 format=rtu unit=101
```

## Configuring a Port-Connected Master

### *Introduction*

Take special note of the following attributes of this configuration:

- All timers for both masters and slaves are using defaults.
- The range field on the set modbus master command is an index number that Digi One IA uses to identify this master. The range fields on each of the set modbus slave commands identify the individual slaves.
- The slaves field on the set modbus master command then identifies the slaves that belong to this master.
- The value on the unit fields of the set modbus slave commands are hardware addresses for the slaves.
- The format=rtu option on the set modbus master command is optional, since rtu is the default for Modbus communication over the serial port.

### *Configuration*

```
set line range=1 baud=14400
set ports range=1 dev=modbus
set modbus master port=1 slaves=2,5 ra=4 format=rtu
set modbus slave ip=143.191.2.100 range=2 unit=200
set modbus slave ip=143.191.2.155 range=5 unit=100
```

***In This Chapter***

This chapter describes Digi One/PortServer TS 2/4 security features and discusses how to configure them. It presents the following topics:

- Controlling Access to the Digi One/PortServer TS 2/4 Configuration . . . . . 12-2
- Controlling Access to Inbound Ports . . . . . 12-2
- Controlling Access to Outbound Ports. . . . . 12-3
- Controlling Access to the Digi One/PortServer TS 2/4 Command Line . . . . . 12-3
- Issuing User Passwords . . . . . 12-4

## Controlling Access to the Digi One/PortServer TS 2/4 Configuration

Digi One/PortServer TS 2/4 restricts access to the configuration by defining the following types of users:

- The root user, who has unlimited access to Digi One/PortServer TS 2/4 commands. He or she can view any configuration table and change any configuration parameter. The root is identified by the user name root and must supply a password to be authenticated. The default root password is dbps. You should change this password immediately.
- Regular users, who have much more restricted access to Digi One/PortServer TS 2/4 commands. Regular users can view some configuration tables and can change some configuration parameters related to their own sessions and passwords. See the *Digi One/PortServer TS 2/4 Command Reference* for information on the limitations placed on regular users for each command.

## Controlling Access to Inbound Ports

This section describes methods of controlling access to inbound serial ports. An inbound port is one defined on the dev field of the set ports command for one of the following device types:

- term (used to define terminal connections)
- min (used to define incoming modem connections)
- mio (used to define bi-directional modem connections)
- hdial, hio (used to define computer connections)

### Default Access Restrictions

The default configuration for inbound ports is that a login and password are required to access them.

### Options for Removing Access Restriction

The login and password requirement for inbound ports can be changed by configuring

- The port so that it does not require a login and password. In this case, no one is required to supply a login or password.
- Specific users so that they do not require a password. In this case, some users do not supply passwords, and others are required to.

### Procedure for Changing a Port's Access Requirements

To configure a port so that no one has to login or specify a password, supply a set logins command that specifies the following:

```
set logins range=range login=off passwd=off
```

**Example:** set logins range=1-2 login=off passwd=off

### Procedure for Changing a User's Access Requirements

To configure a user so that he or she does not have to specify a password when accessing an inbound port, supply a set user command that specifies the following:

```
set user name=name password=off
```

where *name* is a name to identify the user

**Example:** set user name=user1 password=off

## Controlling Access to Outbound Ports

This section describes methods for controlling access to outbound serial ports. An outbound port is one defined on the dev field of the set ports command for one of the following device types:

- prn (used to define printer connections)
- mout (used to define outbound modem connections)
- mio (used to define bi-directional modem connections)
- host (used to define host connections)
- modbus

### Default Access

The default for outbound ports is unlimited access.

### Restricting Access to Outbound Ports

Use the set auth command to restrict access to outbound ports. See the description of the set auth command in the *Digi One/PortServer TS 2/4 Command Reference* for more information.

## Controlling Access to the Digi One/PortServer TS 2/4 Command Line

This section describes how to restrict access to the Digi One/PortServer TS 2/4 command line.

### Method 1 Autoconnection

The autoconnection feature allows you to configure a user to access the Digi One/PortServer TS 2/4 but then be automatically connected to a host on the LAN.

You can implement autoconnection in the following ways:

- By port. In this case, all port users are automatically connected to the same host. The Digi One/PortServer TS 2/4 is completely transparent to them.
- By user. In this case, a user is required to login and may be required to supply a password, but once the user is authenticated, an automatic connection to a hosts made.

For information on configuring autoconnection, see "Configuring Autoconnection" on page 7-1.

### Method 2: Menus

Menus select destination systems without having to access the Digi One/PortServer TS 2/4 command line. For information on configuring menus, see the description of the set menu command in the *Digi One/PortServer TS 2/4 Command Reference*.

# Issuing User Passwords

This section discusses how to issue user passwords.

## Related Information

See the `newpass` and `set user` commands in the *Digi One/PortServer TS 2/4 Command Reference*.

## Starting Point

This procedure assumes that you have signed on as root and already configured the user to whom you will be issuing a password.

## Procedure

1. Issue a `newpass` command that identifies the user (on the name field) to whom this password will be issued.
2. When the system prompts you for a new password, type in the password and then press Enter.
3. When the system prompts you to enter the new password again, type it in and then press Enter.

## Example

In this example, the `newpass` command initiates a dialog with Digi One/PortServer TS 2/4 that results in the user being assigned a password.

```
newpass name=edm1001
```

***In This Chapter***

This chapter discusses how to configure Digi device to use DNS. Topics discussed include the following:

- About the Domain Name System. . . . . 13-2
- Configuration Procedures. . . . . 13-3

# About the Domain Name System

This section discusses key concepts of the domain name system.

## Purpose of DNS

The domain name system maps domain names to information associated with these names, such as IP addresses.

## DNS Components

DNS components include:

- A distributed database consisting of domain names and associated information
- A hierarchical system of domain name servers that maintain the database and use it to respond to requests for information about a particular domain name, such as its IP address
- Domain name resolvers that
  - Accept requests from users
  - Satisfy information requests by building and submitting properly formulated queries to one or more name servers or by retrieving information from a local host file
  - Return information to users
  - Cache information for future use

## Types of Name Servers

There are two types of name servers in the domain name system:

- Local servers maintain information for resources within a local zone. It is up to individual network administrators to determine the scope of a local zone.
- Root servers maintain information in higher-level domains than do local servers.

Typically, when a user requires information about a domain name, the resolver queries a local server. If local servers cannot provide the information, root servers are queried next.

## Naming Conventions

Each node in the domain name system has a globally unique domain name that consists of its own name, which is called a label, and the labels of all superior nodes.

## DNS Name Example

Here is an example of a domain name. Note that labels are separated by periods:

mn07.amalgamated.com

In this example, mn07 is part of the higher-level domain called amalgamated.com.

# Configuration Procedures

## Procedure for Using a Name Server

To configure a DNS server, enter the following command:

```
set config domain=domain myname=name dns=ip-address
```

where

- *domain* is the domain in which the Digi device will reside
- *name* is a DNS name for Digi device
- *ip-address* is the IP address of a name server

Example: `set config domain=digi.com myname=poe dns=204.221.1.4`

## Procedure for Using a Host File

Use this section to configure the host table, which maps IP addresses to host names.

Enter the following command

```
set host name=name ip=ip-address
```

where

- *name* is the name the host
- *ip-address* is the IP address of the host

### *Example*

In this example, three IP address-to-name mappings are configured

```
set host name=poe ip=204.221.110.200
```

```
set host name=gary ip=204.221.110.202
```

```
set host name=toni ip=204.221.110.203
```



***In This Chapter***

This chapter describes how to configure the Digi One/PortServer TS 2/4 SNMP agent. It discusses the following topics:

- About SNMP and the Digi One/PortServer TS 2/4 Agent. . . . . 14-2
- Configuration Procedure: Web Interface . . . . . 14-3
- Configuration Procedure: Command Line. . . . . 14-3

## About SNMP and the Digi One/PortServer TS 2/4 Agent

This section introduces SNMP and network management in TCP/IP networks, and it describes the Digi One/PortServer TS 2/4 agent. It discusses the following:

- Network management components
- The SNMP agent
- SNMP traps
- The Digi One/PortServer TS 2/4 agent's MIB support
- The Digi One/PortServer TS 2/4 agent's supported traps

### Network Management Components

The TCP/IP network management architecture contains the following components:

- Managed nodes such as host systems, routers, terminal and communications servers (such as Digi One/PortServer TS 2/4) and other network devices
- One or more network managers (also called network management stations), which are the points from which the network is managed
- Agents that reside on managed nodes and retrieve management information and communicate this information to network managers
- The network management protocol, SNMP, which governs the exchange of information between the nodes and stations
- Management information, which is the database of information about managed objects. This database is called the management information base (MIB).

### SNMP Management Agent

Each managed node contains at least one agent—a component that responds to requests from the network manager—that retrieves network management information from its node and notifies the manager when significant events occur.

### SNMP Traps

A mechanism defined by SNMP is called a trap, which is a report or “alarm” from a managed node to an SNMP manager that a significant event has occurred.

### MIB Support

The agent supports the following MIBs:

- Read-write for MIB II (RFC 1213), which is an Internet-standard MIB, consisting of managed objects from the systems, interfaces, IP, ICMP, TCP, UDP, transmission, and SNMP group
- Read-write for the character-stream devices using SMIV2 MIB (RFC 1658)
- Read-write for the RS-232-like hardware devices MIB (RFC 1659)
- Read-write for the Digi One/PortServer TS 2/4 IP Network Control Protocol of the Point-to-Point Protocol MIB (RFC 1473)

### Message Support

The SNMP agent supports the Set, Get, GetNext, and Trap messages as defined in RFC 1157. These messages are used as follows:

- Set, which means set the value of a specific object from one of the supported MIBs
- Get, which means retrieve the value of a specific object from one of the supported MIBs
- GetNext, which means retrieve the value of the next object in the MIB
- Trap, which means send traps to the manager when a particular type of significant event occurs

### Supported Traps

The agent can send traps when any of the following occur:

- Cold starts (Digi One/PortServer TS 2/4 initializes)
- Authentication failures

## Configuration Procedure: Web Interface

1. Access the web interface by entering the Digi One/PortServer TS 2/4 IP address in a browser's URL window.
2. Log in to the Digi One/PortServer TS 2/4 as root.  
The default password is dbps, which should be changed. See the `newpass` command in the *Digi One/PortServer TS 2/4 Command Reference* for information on changing passwords.
3. Select Configure and then SNMP from the menu.
4. Fill in the configuration fields and then press Submit.

## Configuration Procedure: Command Line

This section describes how to configure PortServer's SNMP agent.

### Related Information

See the `set snmp` command in the *Digi One/PortServer TS 2/4 Command Reference*.

### Starting Point

This procedure assumes that you have gathered the following information:

- The IP address of the manager to which traps are sent
- The name and location of the SNMP contact person
- The SNMP name of the PortServer you are configuring

### Procedure

Issue a `set snmp` command to configure Digi One/PortServer TS 2/4's SNMP agent. Specify the following:

- The ip address of an SNMP management station to which traps are to be sent on the `trap_dest` field
- A name for this Digi One/PortServer TS 2/4 on the `name` field
- A description of where Digi One/PortServer TS 2/4 is located on the `location` field. If there are spaces in this entry, enclose it in quotation marks.
- The name of an SNMP contact person on the `contact` field. If there are spaces in this entry, enclose it in quotation marks.
- Whether authentication traps are generated when an authentication error occurs on the `auth_trap` field
- Whether the SNMP agent should run immediately on the `run` field

### Configuration Example

```
set snmp auth_trap=on trap_dest=190.174.150.10 location="Digi Minnesota"  
name=blaze contact="bill jones" run=on
```



***In This Chapter***

This chapter provides information on updating the operating system (OS) and managing the configuration. Topics include the following:

- Upgrading the OS (Firmware): Command Line ..... 15-2
- Configuring Digi One/PortServer TS 2/4 from a Remote Host..... 15-3
- Resetting the Configuration to Defaults. .... 15-5

## Upgrading the OS (Firmware): Command Line

This section describes how to upgrade the Digi One/PortServer TS 2/4 operating system (OS). The OS is stored in flash ROM and can be upgraded without changing the ROM or other hardware.

### Related Information

See the boot and set config commands in the *Digi One/PortServer TS 2/4 Command Reference*.

### Procedure

This procedure assumes that you have logged in as root.

1. Obtain a copy of the latest Digi One/PortServer TS 2/4 OS from the Digi International web site, digi.com, and copy it to a host running TFTP.
2. Load the new OS into flash ROM by supplying a boot command that specifies the following on the load field:
  - The IP address of the TFTP host
  - The name of the file that holds the new OS

The following message should appear: The image in flash now appears valid.

3. If this message does not appear, do **not** reboot Digi One/PortServer TS 2/4. The unit may become inoperative if you do; call technical support for instruction on what to do next.
4. If you want to confirm this operation, reboot from the OS in flash ROM by specifying boot action=reset.

### Example

The following is an example of the commands you supply to complete the OS upgrade procedure. The example does **not** include steps that do not use Digi One/PortServer TS 2/4 commands, such as obtaining a copy of the new OS or checking that the new OS runs properly.

```
set config boothost=199.247.89.12 bootfile=//bootfle1 tftpboot=smart
boot action=reset
set config
boot load=199.247.89.12://bootfle1
set config tftpboot=no
boot action=reset
```

## Configuring Digi One/PortServer TS 2/4 from a Remote Host

This section discusses remote configuration, that is, configuring Digi One/PortServer TS 2/4 from a remote host and then downloading the configuration file to Digi One/PortServer TS 2/4.

### When To Use Remote Configuration

Typically, you use remote configuration when you have several Digi One/PortServer TS 2/4s with similar configurations and want to keep a master configuration on a remote host, from which you can easily create variations for downloading to individual Digi One/PortServer TS 2/4s.

### Rules for Editing a Configuration file

Here are some rules for editing a configuration file on a remote host:

- Edit the file with any text editor.
- Each line of the file must start with a set command, such as set user or set line. In other words, do not let commands wrap to the next line if your editor supports this function.

### Copying the Configuration File to a Host

This section describes how to copy the Digi One/PortServer TS 2/4 configuration file to a remote host for editing.

#### *Related Information*

See the cpconf command in the *Digi One/PortServer TS 2/4 Command Reference*.

#### *Starting Point*

This procedure assumes that you

- Have an existing configuration on the Digi One/PortServer TS 2/4 that you want to copy to a remote host for editing
- Are logged in to Digi One/PortServer TS 2/4 as root, which is a requirement for using the cpconf command to copy the configuration file to a host

#### *Procedure*

1. Create a file with appropriate write permissions on the remote host.
2. Ensure that TFTP is running on the remote host.
3. Supply a cpconf command with a tohost field that specifies the following:
  - The IP address of the target host
  - The name of the file that will hold the configuration.

#### *Example*

```
cpconf tohost=199.250.121.12:cnfg-file
```

## Copying a Configuration File from a Host to Digi One/PortServer TS 2/4

This section describes how to copy the configuration file from a host to Digi One/PortServer TS 2/4 after the file has been edited on the host.

### *Related Information*

See the `cpconf` command in the *Digi One/PortServer TS 2/4 Command Reference*.

### *Starting Point*

This procedure assumes that you

- Have edited a configuration file on a host and now want to copy it to Digi One/PortServer TS 2/4 for use
- Are logged in to Digi One/PortServer TS 2/4 as root, which is a requirement for using the `cpconf` command to copy the configuration file to a host

Supply a `cpconf` command with a `fromhost` field that specifies the following:

- The IP address of the source host
- The name of the configuration file on the host

### *Example*

```
cpconf fromhost=199.250.121.12:cnfg-file
```

## Resetting the Configuration to Defaults

Use this section to learn how to use the revert command to reset the all or some of the configuration factory or to the latest configuration stored in NVRAM.

**Note:** You can also use the range field on this command to define a range of ports with the serial, port, line, flow, keys and login options.

To Reset the ...	To factory defaults specify ...	To the latest version in NVRAM specify...
Entire configuration	revert all=factory	revert all=nvram
altip configuration	revert altip=factory	revert altip=nvram
arp configuration	revert arp=factory	revert arp=nvram
auth configuration	revert auth=factory	revert auth=nvram
set config configuration	revert config=factory	revert config=nvram
set flow configuration	revert flow=factory	revert flow=nvram
set host configuration	revert host=factory	revert host=nvram
set keysconfiguration	revert keys=factory	revert keys=nvram
set line configuration	revert line=factory	revert line=nvram
set logins configuration	revert login=factory	revert login=nvram
menu configuration	revert menu=factory	revert menu=nvram
Modbus	revert modbus=factory	revert modbus=nvram
altip, arp, host, route, snmp, tcpip, and telnetip	revert network=factory	revert network=nvram
set ports	revert port=factory	revert port=nvram
Routing	revert routed=factory	revert routed=nvram
set auth, set logins, and set radius	revert security=factory	revert security=nvram
set flow, set line, set ports	revert serial=factory	revert serial=nvram
set service	revert service=factory	revert service=nvram
SNMP configuration	revert snmp=factory	revert snmp=nvram
set config, set keys, set menu, set service, set terms, set trace, and set user	revert system=factory	revert system=nvram
set tcpip	revert tcpip=factory	revert tcpip=nvram
set telnetip	revert telnetip=factory	revert telnetip=nvram
set terms	revert terms=factory	revert terms=nvram
Trace settings	revert trace=factory	revert trace=nvram
set user	revert users=factory	revert users=nvram



This chapter provides several simple, but complete, configuration examples. If you find that the examples implement exactly the features needed for your network, simply copy them, making appropriate substitutions for site-specific information such as IP addresses. Quite likely, however, you will be able to use the examples as a starting point only and will need the information provided in other chapters in this manual and in the *Digi One/PortServer TS 2/4 Command Reference* to complete your configuration.

***In This Chapter***

This chapter provides the following discussions:

- Terminal Server Configuration Without RealPort . . . . . 16-2
- Terminal Server Configuration Using Autoconnection . . . . . 16-3
- Terminal Server Configuration Using RealPort . . . . . 16-4
- Dial-Out PPP Connection to a Host . . . . . 16-5
- Dial-Out PPP Network-to-Network Connection . . . . . 16-7
- Dial-In PPP Connection and Proxy ARP . . . . . 16-10

## Terminal Server Configuration Without RealPort

In this configuration, Digi One/PortServer TS 2/4 functions as a terminal server, providing Telnet and Rlogin access to hosts. This configuration enables the following:

- Telnet or Rlogin access to the LAN-based hosts, both from locally-connected terminals and from devices accessing the LAN from the telephone network.
- Access for the LAN-based hosts to Digi One/PortServer TS 2/4 ports (sometimes called reverse Telnet)

### Related Information

For more information on configuring

- The Ethernet interface, see "Configuring the IP Address" on page 1-1.
- Terminal connections, see "Configuring Ports for Terminals and Computers" on page 6-1.
- Modem connections, see "Configuring Ports for Modems" on page 5-1.

### Illustration

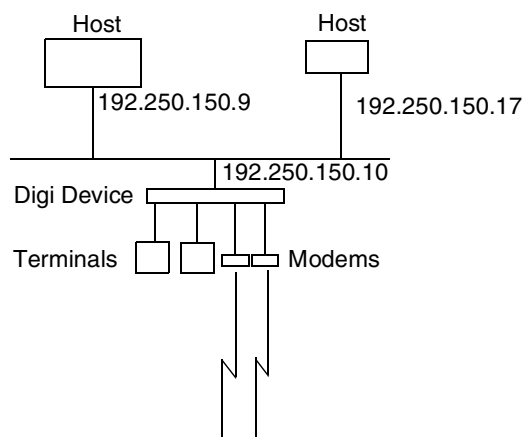

### Configuration

```
set config ip=192.250.150.10 submask=255.255.255.0 (1)
set ports range=1-2 dev=term
set line range=1-2 baud=9600
set flow range=1-2 ixon=on ixoff=on (2)
set ports range=3-4 dev=mio
set line range=3-4 baud=115200
set flow range=3-4 ixon=off ixoff=off rts=on cts=on (3)
set user name=user1 (4)
```

### Configuration Notes

1. The set config command configures the IP address and mask for the Digi One/PortServer TS 2/4 Ethernet interface.
2. The first set ports, set line, and set flow commands configure ports 1 and 2 for terminal connections.
3. The next set ports, set line and set flow commands configure the ports for bidirectional modems. Software flow control (the default) is explicitly shut off and hardware flow control turned on using the set flow command.
4. The set user command defines a user, which assigns a user name for login purposes. All Digi One/PortServer TS 2/4 users can login with this name.

# Terminal Server Configuration Using Autoconnection

This example shows a Digi One/PortServer TS 2/4 functioning as a terminal server implementing autoconnection.

- The terminals are connected to autoconnect ports. Consequently, when a user presses a terminal key, an automatic connection to a host is made.
- The modem ports are not configured for autoconnection, but a port user is, which means that as soon as this particular user supplies a login, an automatic connection to a host is made.

## Related Information

For more information on configuring

- The Ethernet interface, see "Configuring the IP Address" on page 1-1.
- Terminal connections, see "Configuring Ports for Terminals and Computers" on page 6-1.
- Modem connections, see "Configuring Ports for Modems" on page 5-1.

## Illustration

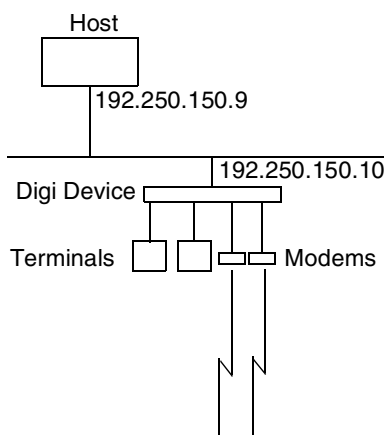

## Configuration

```
set config ip=192.250.150.10 submask=255.255.255.0
set ports range=1-2 dev=term auto=on dest=192.250.150.9 dport=23
set line range=1-2 baud=9600
set flow range=1-2 ixon=on ixoff=on (1)
set ports range=3-4 dev=min
set line range=3-4 baud=115200
set flow range=3-4 ixon=off ixoff=off rts=on cts=on (2)
set user name=user1 autoconnect=on defaultaccess=autoconnect
autohost=192.250.150.9 autoport=23 password=off (3)
```

## Configuration Notes

1. The first set of set ports, set line and set flow commands configure ports 1 and 2 for terminals, autoconnection, Telnet (dport=23), and software flow control.
2. The second set ports, set line, and set flow commands set up ports 3 and 4 for incoming modem connections and RTS/CTS flow control.
3. The set user command configures the user for automatic connection to the host specified on the autohost field using Telnet (autoport=23).

## Terminal Server Configuration Using RealPort

In this example, the Digi One/PortServer TS 2/4 is simply providing ports for the LAN-based host using RealPort. The configuration is exceedingly simple because port attributes are configured on the host itself.

### Related Information

For more information on configuring:

- The Ethernet interface, see "Configuring the IP Address" on page 1-1
- RealPort, see "Configuring Ports for RealPort" on page 3-1

### Illustration

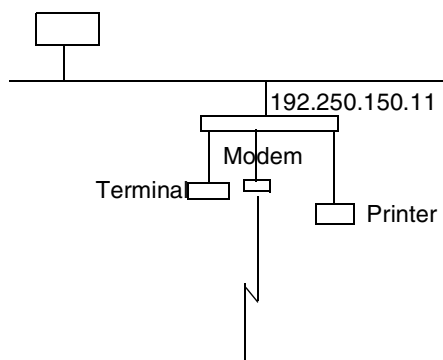

### Configuration

```
set config ip=192.250.150.11 submask=255.255.255.0 (1)
set ports range=2-4 dev=rp (2)
```

### Configuration Notes

1. The set config command configures the internet address and mask for Digi One/PortServer TS 2/4 Ethernet interface.
2. The set ports command configures ports 2, 3, and 4 for Realport. This command specifies dev=rp, which is an appropriate device type for RealPort.

## Dial-Out PPP Connection to a Host

In this configuration, Digi One/PortServer TS 2/4 has a dialout PPP link to a host.

### Related Information

For more information on configuring

- The Ethernet interface, see "Configuring the IP Address" on page 1-1.
- IP routing, see "Configuring IP Routing" on page 9-1
- Modem connections, see "Configuring Ports for Modems" on page 5-1
- Modem and login scripts, see the set scripts command in the *Digi One/PortServer TS 2/4 Command Reference*
- PPP connections, see "Configuring PPP" on page 8-1.

### Illustration

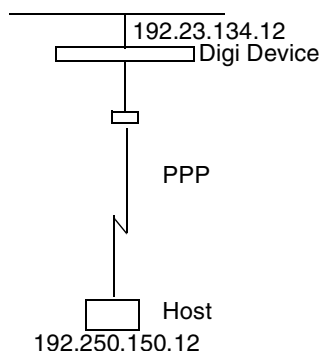

### Configuration

```
set config ip=192.23.134.12 submask=255.255.255.0
set forwarding state=passive (1)
set ports range=2 dev=mout
set line range=2 baud=115200
set flow range=2 ixon=off ixoff=off rts=on cts=on (2)
set script name=dialstd
  s1="M{atdt%n\r} [BUSY]* [CONNECT]+ S50 T=" (3)
set device name=netdev dialer=dialstd ports=2 (4)
set user name=user1 netservice=on defaultaccess=netservice protocol=ppp
  pppauth=none
set user name=user1 ipaddr=192.250.150.12 ipmask=255.255.255.0
set user name=user1 localipaddr=192.250.150.11
set user name=user1 loginscript=loginscript p1=fuzz p2=fuzz
  n1=555-1234
set user name=user1 device=netdev dialout=on (5)
```

## Configuration Notes

1. The set forwarding command configures routing using RIP, though state=passive means that Digi One/PortServer TS 2/4 will listen for routing updates but not send them out.
2. The set ports, set line and set flow commands configure port 2 for a dialout modem using hardware flow control.
3. The set scripts command configures a dialer script.
4. The set device command references the dialer script to be used for port 2.
5. The set user commands configure attributes of the PPP link, which include the following:
  - PPP connections can be initialized (netservice=on)
  - No CHAP or PAP authentication (pppauth=none)
  - The IP address of the remote peer (on the ipaddr field)
  - A reference to the default login script (on the loginscript field)
  - The login name and password that this user uses on the remote system (on the p1 and p2 fields), which are passed to the remote system by login script.
  - The telephone number that is used by the dialer script (on the n1 field)
  - dialout=on, which enables this outbound PPP connection

## Dial-Out PPP Network-to-Network Connection

In this configuration, Digi One/PortServer TS 2/4 functions as a router in a LAN-to-LAN configuration.

### Related Information

For more information on configuring

- IP routing, see "Configuring IP Routing" on page 9-1
- Modem connections, see "Configuring Ports for Modems" on page 5-1
- Modem scripts, see the set scripts command in the *Digi One/PortServer TS 2/4 Command Reference*
- PPP connections, see "Configuring PPP" on page 8-1

### Illustration

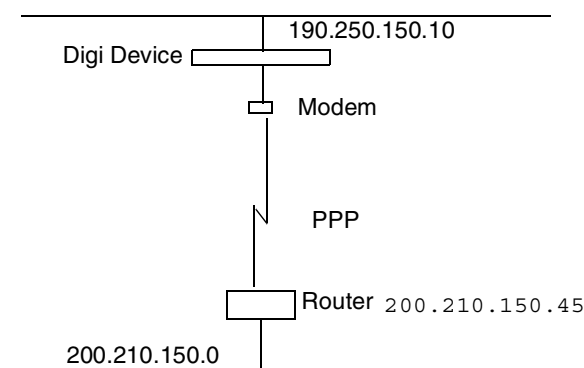

### Configuration

```
set config ip=190.250.150.10 submask=255.255.255.0 (1)
set forwarding state=active (2)
set ports range=9 dev=mout
set line range=9 baud=115200
set flow range=9 ixon=off ixoff=off rts=on cts=on (3)
set script name=dialer1 s1="M{atdt%n\r} [BUSY]* [CONNECT]+ S50 T=" (4)
set device name=netdev dialer=dialstd ports=9 (5)
set user name=user1 protocol=ppp mtu=1500 netservice=on
set user name=user1 defaultaccess=netservice
set user name=user1 ipaddr=200.210.150.45 dialout=on ipmask=255.255.0.0
set user name=user1 localipaddr=200.210.150.46
set user name=user1 pppauth=none device=netdev
set user name=user1 localipaddr=192.250.150.11
set user name=user1 loginscript=loginscript p1=jnne p2=jnne n1=555-1234
set user name=user1 netrouting=both (6)
```

### Configuration Notes

1. The set config command configures Digi One/PortServer TS 2/4 Ethernet interface.
2. The set forwarding command configures Digi One/PortServer TS 2/4 for dynamic routing. The state=active field means that Digi One/PortServer TS 2/4 both sends and receives routing updates.
3. The set ports, set line and set flow commands configure port 9 for outbound modem connections using CTS/RTS flow control.

4. The set script command configures a dialer script that is referenced by a set device and set user commands.
5. The set device command references the dialer script to be used for port 9.
6. The set user commands configure the attributes of the PPP link.

## PPP Dial-In Connection

In this configuration, Digi One/PortServer TS 2/4 provides a dial-in PPP connection.

### Related Information

For more information on configuring

- Modem connections, see "Configuring Ports for Modems" on page 5-1.
- PPP connections, see "Configuring PPP" on page 8-1.
- IP pools, see the set ippool command in the *Digi One/PortServer TS 2/4 Command Reference*.

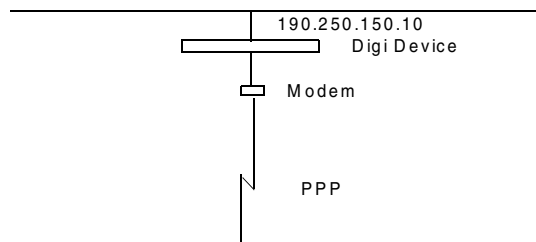

### Configuration

```
set config ip=190.250.150.10 submask=255.255.255.0

set ports range=9 dev=min
set line range=9 baud=115200
set flow range=9 ixon=off ixoff=off rts=on cts=on (1)
set ippool count=3 ip=190.250.150.11 (2)
set user name=ppp1 protocol=ppp mtu=1500 ipaddr=ippool pppauth=none
set user name=ppp1 defaultaccess=netSERVICE netSERVICE=on compression=vj
set user name=ppp1 localipaddr=190.250.150.20 (3)
```

### Configuration Notes

1. The set ports, set line and set flow commands configure port 9 for incoming modem connections using RTS/CTS.
2. The set ippool command configures an IP address pool for remote PPP users.
3. The set user command configures attributes of the PPP connection.

## Dial-In PPP Connection and Proxy ARP

In this example, Digi One/PortServer TS 2/4 performs Proxy ARP services for a PC located across a PPP link.

### Related Information

For more information on configuring

- PPP connections, see "Configuring PPP" on page 8-1
- Proxy ARP, see "Configuring Proxy ARP" on page 9-7.

### Illustration

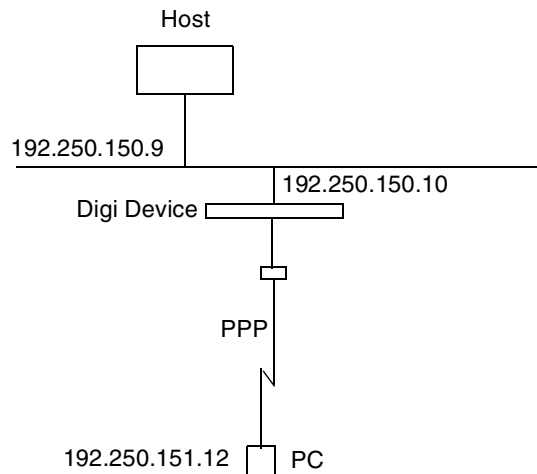

### Configuration

```
set config ip=192.250.150.10 submask=255.255.255.0
set ports range=2 dev=min
set line range=2 baud=115200
set flow range=2 ixon=off ixoff=off rts=on cts=on (1)
set user name=user1 protocol=ppp mtu=1500 defaultaccess=netSERVICE
set user name=user1 netSERVICE=on ipaddr=192.250.151.12
set user name=user1 localipaddr=192.250.151.11
set user name=user1 compression=vj pppauth=none (2)
set forwarding state=active proxyarp=on (3)
```

### Configuration Notes

1. The set ports, set line and set flow commands configures port 2 for an incoming modem connection.
2. The set user commands configure attributes of the PPP connection.
3. The set forwarding command specifies proxyarp=on.

*In This Chapter*

- Symptom: Digi One/PortServer TS 2/4 Does Not Boot . . . . . 17-2
- Symptom: Cannot Telnet to the Digi One/PortServer TS 2/4 . . . . . 17-3
- Symptom: Trouble Accessing a Port . . . . . 17-4
- Running Digi One/PortServer TS 2/4 Customer Diagnostics . . . . . 17-4
- Key to Interpreting Digi One/PortServer TS 2/4 LEDs . . . . . 17-5
- Verifying TFTP on a UNIX System . . . . . 17-5
- Troubleshooting TFTP Problems . . . . . 17-5
- Resetting Digi One/PortServer TS 2/4 Configuration to Defaults . . . . . 17-6
- Verifying the Digi One/PortServer TS 2/4 IP Address . . . . . 17-7
- Checking for Duplicate IP Addresses . . . . . 17-7
- Pinging an IP Address . . . . . 17-7
- Verifying the Network Cabling . . . . . 17-8
- Verifying the RealPort Process . . . . . 17-9
- Digi Contact Information . . . . . 17-11

## Symptom: Digi One/PortServer TS 2/4 Does Not Boot

### *Introduction*

Use the information provided in this discussion when Digi One/PortServer TS 2/4 will not complete the boot cycle.

### *Procedures*

<b>Things to Try</b>	<b>See ...</b>
Check for hardware problems.	<ul style="list-style-type: none"><li>• "Running Digi One/PortServer TS 2/4 Customer Diagnostics" on page 17-4</li><li>• "Key to Interpreting Digi One/PortServer TS 2/4 LEDs" on page 17-5</li></ul>
Check for TFTP problems if Digi One/PortServer TS 2/4 is booting from a TFTP host.	<ul style="list-style-type: none"><li>• "Verifying TFTP on a UNIX System" on page 17-5</li><li>• "Troubleshooting TFTP Problems" on page 17-5</li></ul>
Resetting the device to configuration defaults.	"Resetting Digi One/PortServer TS 2/4 Configuration to Defaults" on page 17-6
If you cannot resolve the problem, contact Digi.	"Digi Contact Information" on page 17-11

## Symptom: Cannot Telnet to the Digi One/PortServer TS 2/4

### *Introduction*

Use the information provided in this discussion to troubleshoot network problems.

### *Assumptions*

This discussion assumes that the Digi One/PortServer TS 2/4 itself is working, that is, that it completes the boot cycle.

### *Procedures*

Things to Try	See ...
Verify the IP address. This procedure ensures that you are using the right IP address to Telnet to the Digi One/PortServer TS 2/4.	"Verifying the Digi One/PortServer TS 2/4 IP Address" on page 17-7
Check for duplicate IP address. This procedure ensures that two devices are not using the same IP address.	"Checking for Duplicate IP Addresses" on page 17-7
See if you can ping the IP address. If you can ping the address, but cannot Telnet to it, you probably have a firewall problem. See the Firewall documentation for more information.	"Pinging an IP Address" on page 17-7
Verify the network cabling.	"Verifying the Network Cabling" on page 17-8
If you cannot resolve the problem, contact Digi.	"Digi Contact Information" on page 17-11

## Symptom: Trouble Accessing a Port

### Introduction

Use this procedure if you are having trouble accessing a Digi One/PortServer TS 2/4 port. The specific problem might be that you cannot logon from a terminal or the printer or modem is not working properly.

### Assumptions

This discussion assumes the following:

- That the Digi One/PortServer TS 2/4 itself is working, that is, that it completes the boot cycle. If it is not, see "Symptom: Digi One/PortServer TS 2/4 Does Not Boot" on page 17-2.
- That the network is working. This is a relevant consideration if the ports you are working with are RealPort ports and if all RealPort ports are not working. The discussion in "Symptom: Cannot Telnet to the Digi One/PortServer TS 2/4" on page 17-3 goes through the steps of validating the network connection.

### Procedures

Things to Try	See ...
If this is a RealPort port and all ports are not working, ensure that the RealPort process is running.	"Verifying the RealPort Process" on page 17-9
Verify Digi One/PortServer TS 2/4 port settings.	Check the port configuration in the <i>Digi One/PortServer TS 2/4 Command Reference</i> . Look under the set ports, set line, and set flow commands for more information.
Verify the cabling to the peripheral	See the Cable Guide for information.

## Running Digi One/PortServer TS 2/4 Customer Diagnostics

Use this topic to run hardware diagnostic procedures to validate the Digi One/PortServer TS 2/4.

1. Connect a terminal to a Digi One/PortServer TS 2/4 port.
2. Configure the terminal to use the following settings:
  - VT-100 emulation
  - 9600 baud
  - 8-bit characters
  - 1 stop bit
  - No parity
3. Reboot the Digi One/PortServer TS 2/4.
4. While the LED is blinking, press the v key.
5. When the Customer Diagnostics Menu appears, select a test to perform.

## Key to Interpreting Digi One/PortServer TS 2/4 LEDs

Here is a key to interpreting Digi One/PortServer TS 2/4 LEDs

### Procedure

LED Activity	Indication
1-1-1 pattern	Starting the EOS.
1-3-1 pattern	TFTP boot process started
1-5-1 pattern	Tells you that configuration has been return to the factory configuration. See "Resetting Digi One/PortServer TS 2/4 Configuration to Defaults" on page 17-6.
Steady blinking	Device seeking an IP address from DHCP server.
Solid	On Digi One RealPort and PortServer TS 2/4 devices, this means the boot completed successfully. On Digi One IA devices, it indicates a problem.

## Verifying TFTP on a UNIX System

Use this procedure to verify that TFTP is working correctly on your UNIX host.

**Note:** This procedure, which uses a TFTP transfer of the Digi Device's boot image between two UNIX hosts, enables you to compare the size of the boot image before and after it is transferred, enabling you to determine if TFTP is working properly.

### Procedure

1. Access a root prompt on the UNIX host.
2. Make sure that you are not in the /tftpboot directory.
3. Enter this command:

```
tftp ipaddress
```

where *ipaddress* is the IP address of the UNIX host.

A TFTP prompt appears.

4. At the prompt, enter the following command:

```
binary
```

5. Enter this command at the TFTP prompt:

```
get tftp_file_name
```

where *tftp\_file\_name* is the name of the Digi Device's boot image in the /tftpboot directory.

6. Enter this command at the TFTP prompt to exit TFTP:

```
quit
```

7. Compare the size of the original file against the transferred file using this command:

```
cmp -l tftp_file_name /tftpboot/tftp_file_name
```

If the data within the files to see if TFTP is working properly. If they are the same, no message will be generated.

## Troubleshooting TFTP Problems

Here are some things to check if you encounter TFTP problems.

- Verify that the /tftpboot directory exists and has read, write and execute (777) permissions with this command:

```
ls -l /tftpboot
```

If necessary, use this command to create the directory:

- ```
mkdir /tftpboot
```
- If necessary, use this command to change permissions of the directory to read, write and execute:
 

```
chmod 777 /tftpboot
```
  - Verify that the file /tftpboot/tftp\_file\_name exists and has read and execute permissions with this command:
 

```
ls -l /tftpboot/tftp_file_name
```

 where *tftp\_file\_name* is the name of the firmware boot image specified by the Digi Device.
 

If necessary, use this command to change permissions of the file to read and execute:

```
chmod 666 /tftpboot/tftp_file_name
```
  - Verify that the inetd.conf file is properly configured for tftp by displaying the file /etc/inetd.conf.
 An entry similar to this should be uncommented:
 

```
tftp dgram udp something
```

 where *something* will vary with each operating system.
 

For controlled TFTP access, make sure that the file /etc/tftpaccess.ctl exists and verify that it only allows access to public directories. If this file is not present, tftp will allow full access. A sample file is located in the directory /usr/lpp/tcpip/samples.
  - Restart the inetd process with these two commands:
 

```
ps -ef | grep inetd
```

 This will report back the inetd process number.
 

```
Kill -1 inetd_PID
```

 Where *inetd\_PID* is the process number for the inetd process reported by the previous command.

## Resetting Digi One/PortServer TS 2/4 Configuration to Defaults

Use this topic to reset the Digi One/PortServer TS 2/4 configuration to defaults.

- Note:** This procedure causes the Digi One/PortServer TS 2/4 to lose all configuration changes. If you have a complex configuration, contact Digi before performing for information on saving your configuration. See "Digi Contact Information" on page 17-11 for information.

### Procedure

1. Use a pen, the point of a paper clip, or some other device to press the recessed button on the front panel.
2. While holding down the button, power on the Digi One/PortServer TS 2/4.
3. When the 1-5-1 LED pattern is displayed, release the button.
 

The device boots up.

## Verifying the Digi One/PortServer TS 2/4 IP Address

Use this procedure to check the IP address on the Digi One/PortServer TS 2/4.

1. Connect a terminal to a Digi One/PortServer TS 2/4 port.
2. If the port is still using the default configuration, configure the terminal to use the following settings (Otherwise, configure the terminal to match the port configuration):
  - VT-100 emulation
  - 9600 baud
  - 8-bit characters
  - 1 stop bit
  - No parity
3. Press Enter to get a logon prompt from the Digi One/PortServer TS 2/4.
4. Log on to the Digi One/PortServer TS 2/4.
5. Use the set config command to verify the Digi One/PortServer TS 2/4 IP address.

## Checking for Duplicate IP Addresses

Use this procedure to ensure that the Digi One/PortServer TS 2/4 and another device are not using the same IP address.

### *Procedure*

1. From another system on the network, use the ping command to determine if the IP address is in use. The following is the command syntax:  

```
ping ip-address
```
2. Do one of the following:
  - If there is no response to the ping, exit this procedure and return to the symptoms section of this section. Two devices using the same IP address is probably not a problem.
  - If there is a response, continue with this procedure.
3. Turn the Digi One/PortServer TS 2/4 off and then ping again.
4. Do one of the following:
  - If there is a response to the ping, there is another device using that IP address, so assign one of the devices a new IP address.
  - If there is no response, turn the Digi One/PortServer TS 2/4 back on. Another device is not using the IP address assigned Digi One/PortServer TS 2/4.

## Pinging an IP Address

Use this procedure to determine if a system can be reached from across a network.

### *Procedure*

Attempt to ping the Digi One/PortServer TS 2/4 from another system on the network. Here is the format of the command:

```
ping ip-address
```

## Verifying the Network Cabling

Use this procedure to troubleshoot network cabling problems.

1. Check the Ethernet cable. Verify the following:
  - The Ethernet cable is connected securely at both ends.
  - The Ethernet cable is pinned correctly.
  - The quality of the cable is sufficient for the cable length and the cable environment. Common Category 5 Unshielded Twisted Pair cabling can generally be run 300 meters at a speed of 10 Mbps and 150 meters at higher speeds. Consult an Ethernet cable manufacturer for a recommended cable for your configuration.
2. Verify your Ethernet hub. See your Ethernet hub manual.

## Verifying the RealPort Process

Use one of these procedures to verify the RealPort process:

### AIX: Verifying the RealPort Process

Use this topic to verify that the RealPort daemon (process) is running on the AIX system.

1. Type the following:

```
lsdev -Cc nts
```

2. If the sa devices are not in an available state, type the following from the AIX prompt:

```
mkdev -1 sa#
```

```
cfgmgr
```

where # is the number of the Digi Device.

### HP-UX: Verifying the RealPort Process

1. Verify that RealPort is running on the HP-UX operating system by entering:

```
ps ef | grep drp
```

If you see an entry for each Digi Device similar to the following, the RealPort process is running.

```
root 2254 1 0 Dec 13 ? 0:03/sbin/drpd 1 199.86.0.1 root 2049 1 0  
Dec 13 ? 0:01/sbin/drpd 1 199.86.5.1
```

2. If the daemon is not running, enter this command at a root prompt:

```
/usr/sbin/drpadmin
```

3. Answer the prompts as appropriate.

### Linux: Verifying the RealPort Process

The RealPort daemon (process) controls communication between the RealPort driver module and your Digi Devices across the network. One daemon must remain in the background for each Digi Device, maintaining the communication link. You should not need to start the daemon by hand. The `dgrp_cfg_node` program does this automatically.

However, to determine whether any RealPort daemons are currently running on your system, as well as to determine which Digi Device each daemon is communicating with, you can execute the following command:

```
ps ax | grep drpd
```

For more information about the RealPort daemon, see the `drpd` man page that is installed with the driver package.

### SCO: Verifying the RealPort Daemon

Use this topic to verify that the RealPort daemon is running on a SCO Unix or SCO OpenServer operating system.

1. At the root prompt, enter the following command:

```
ps ef | grep nxcd
```

If the RealPort Daemon is running, you should see an entry for each Digi Device similar to the following?

```
root 2254 1 0 Dec 13 ? 0:03/etc/nxcd -d /dev/cts0 -n  
root 2049 1 0 Dec 13 ? 0:01/etc/nxcd -d /dev/cts0 -n
```

2. If you do not see this information, restart the daemon by doing the following:
  - a. Modify the `/etc/rc2.d/S86ncxa` file with the appropriate IP addresses.
  - b. Reboot the server.

## **Solaris: Verifying the RealPort Process**

Use this topic for information on verifying that the RealPort process is running on a Solaris system.

1. Type the following command:

```
ps -ef |grep ncx
```

2. If the information that appears is not correct, do the following:
  - a. Modify the `/etc/rc2.d/S26realport` file with the appropriate IP addresses.
  - b. Reboot the UNIX server.

## **Windows NT: Verifying the RealPort Service**

Use this procedure to verify the RealPort service on Microsoft Windows NT.

1. From the Start menu, choose Settings > Control Panel > Devices > Digi RealPort.
2. If the RealPort service has not been started, choose Start.

## **Windows 2000: Verifying the RealPort Service**

Use this procedure to verify the RealPort service (process) on Microsoft Windows 2000.

1. Right-click on My Computer, choose Properties > Hardware tab > Device Manager.
2. Expand the Multi-port Serial Adapters list if necessary and select Digi PortServer.
3. If the RealPort Service (process) is not enabled, right-click and choose Enable.

## Digi Contact Information

Digi International  
11001 Bren Road East  
Minnetonka, MN 55343  
U.S.A

| <b>Customer Service and Support</b> |                                                               |
|-------------------------------------|---------------------------------------------------------------|
| World Wide Web:                     | <a href="http://support.digi.com">http://support.digi.com</a> |
| email                               | <a href="mailto:support@digi.com">support@digi.com</a>        |
| Telephone (U.S.)                    | 1-800-344-4273                                                |
| Telephone (other locations)         | (+011) 952-912-3444                                           |

