

Pin Assignments

DB-25 and DB-9 Pin Assignments

Signal	Description	DB-25 Pin	DB-9 Pin
GND	Chassis Ground	Shell	Shell
TxD	Transmitted Data	2	3
RxD	Received Data	3	2
RTS	Request To Send	4	7
CTS	Clear To Send	5	8
DSR	Data Set Ready	6	6
SG	Signal Ground	7	5
DCD	Data Carrier Detect	8	1
DTR	Data Terminal Ready	20	4
RI	Ring Indicator	22	9

RJ-45 Pin Assignments for 10-Pin and 8-Pin RJ-45 Connectors

Signal	Description	Pin # (of 10)	Pin # (of 8)
RI	Ring Indicator	1	N/A
DSR	Data Set Ready	2†	1†
RTS	Request To Send	3	2
GND	Chassis Ground	4	3
TxD	Transmitted Data	5	4
RxD	Received Data	6	5
SG	Signal Ground	7	6
CTS	Clear To Send	8	7
DTR	Data Terminal Ready	9	8
DCD	Data Carrier Detect	10	N/A

† DSR (Pin 2 on a 10 pin connector, Pin 1 on an 8 pin connector) can be swapped with DCD. This reverses the position of these two signals in 10 pin or allows DCD to be used instead of DSR on an 8 pin connector.

Consult the driver documentation for how to do this in your specific operating system.

Refer to the CD-ROM for more detailed cabling information.



AccelePort Xp Family

PCI Host Adapters
EIA-232

Cable Usage Guide

Introduction

An AccelePort® Xp™ host adapter easily expands the number of EIA-232 ports available on your computer, allowing you to cable additional peripheral devices, such as modems, terminals or serial printers, directly to your computer.

This Cable Usage Guide describes the different connector options available from Digi, and methods in which they may be used.

Digi, the Digi logo and AccelePort are trademarks or registered trademarks of Digi International in the United States and other countries. All other brand and product names are trademarks of their respective holders.

© Digi International Inc., 2000 All Rights Reserved; www.digi.com

Information in this document is subject to change without notice and does not represent a commitment on the part of Digi International.

Digi provides this document "as is," without warranty of any kind, either expressed or implied, including, but not limited to, the implied warranties of fitness or merchantability for a particular purpose. Digi may make improvements and/or changes in this manual or in the product(s) and/or the program(s) described in this manual at any time.

This product could include technical inaccuracies or typographical errors. Changes are periodically made to the information herein; these changes may be incorporated in new editions of the publication.

Connector Assembly Options and Part Numbers

Various connector assembly options are available for use with Xp adapters. The tables below provide the Digi part numbers for these options.

Fan-out Cables and Part Numbers

Use the table below to obtain the part numbers for fan-out cable options:

	4-Port	8-Port
DB-25 Male	76000522	76000523
DB-9 Male	76000528	76000529

Fan-out cables can be used with AccelePort 4p, 8p or 16p adapters.

Fan-out cables with female connectors may be obtained by contacting your Digi sales representative.

NOTE: For 16p adapters, use two 8-port fan-out cables.

Connector Boxes and Part Numbers

Connector boxes are available in the following configurations:

	4-Port	8-Port
DB-25 Male	76000524	76000525
DB-9 Male	76000560	76000561
RJ-45 Female	76000526	76000527

The 4-port and 8-port connector boxes may be placed on the desktop or floor, or wall-mounted by attaching a bracket (included with the connector box). The wall-mount bracket can also be used for rack mounting.

NOTE: Two 8-port boxes may be used with a 16p adapter (for example, if DB-9 connectors are required).

Connector Box Interconnect Cable and Part Number

Connector boxes are attached to the AccelePort Xp adapter via a cable equipped with high-density HD-68 connectors. A 6-foot cable is included with 4- and 8-port connector boxes; this may be upgraded to a 10-foot cable:

10-Foot Cable	76000559
----------------------	----------

NOTE: Two 10-foot cables are included with 16p systems.

HD-68 to DB-78 Adapter and Part Number

If you already have connector assemblies for an AccelePort Xr or Xe system, you can use them with the AccelePort Xp by installing an HD-68 to DB-78 adapter assembly:

HD-68 to DB-78 Adapter	76000534
-------------------------------	----------

CAUTION: Many SCSI adapters use the same HD-68 connector type as the AccelePort Xp adapter. Do not plug SCSI devices into the Digi connector, and do not plug Digi peripheral cables into SCSI adapters.

Connector Box Mounting Options

Installing Brackets on 4- and 8-Port Connector Boxes

Use this procedure to install the wall-mount bracket on 4- and 8-port connector boxes. Wall-mount brackets are included with the connector boxes.

1. Remove the two screws from the end of the connector box opposite the HD-68 connector.
2. Use the screws to attach the wall-mount bracket as shown in the figure below. The 4-port DB-25 connector box is shown; the procedure is the same for all 4- and 8-port connector boxes.

Figure 1. Attaching the Wall-mount Bracket to a 4-Port Box

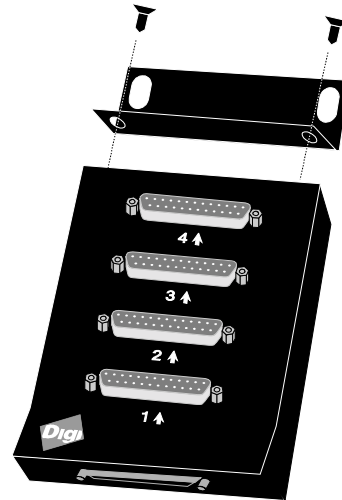

Installing Rack-mount Tabs on 16-Port Connector Boxes

Use this procedure to install the rack-mount brackets on a 16-port connector box.

1. Remove the front two screws from each end of the connector box assembly.
2. Use the screws to attach the rack-mount tabs as shown in the figure below (the figure shows an RJ-45 box; the procedure is similar for DB-25 boxes).

Figure 2. Attaching Rack-mount Tabs to a 16-Port RJ-45 Box

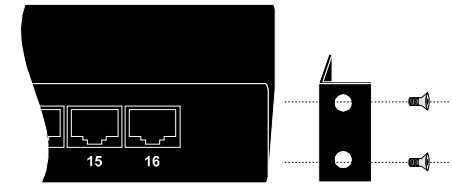

Installing 16-Port DB-25 Connector Boxes on a Desktop

When a 16-port DB-25 connector box is fully loaded, the weight of the cables and connectors may exceed the weight of the connector box itself. This can cause the box to tip over if placed near the edge of the desktop. To prevent this from happening, position the connector box sufficiently far from the edge of the desktop so that the connectors are supported by the desktop.

To add stability to a connector box placed on a desktop, install the rack-mount tabs as shown in Figure 3.

Figure 3. Using Rack-Mount Tab as a Stabilizer

