

## Features

- Line speeds:
  - to 5Mbps—EIA-530/X.21
  - to 2.5 Mbps—V.35
  - to 90 Kbps—Synch. EIA-232
  - to 144 Kbps—Async. EIA-232
- Full modem control
- DMA channels for full duplex operation
- 16KB or Full 256KB shared memory window
- Software configurable
- SurgeBlock surge protection

## Specifications

### Power

- 50mA @ 3.3VDC
- 1.5 A @ 5 VDC
- 90 mA @ +/- 12 VDC

### Environmental

- Temperature: 10° C to 55° C
- Relative Humidity: 5% to 90%, non-condensing
- SurgeBlock: Standard

## Copyright

© Digi International Inc. 1997, 1998, 1999, 2000, 2001, 2002, 2003. All Rights Reserved

The Digi logo is a trademark of Digi International Inc. All other brand and product names are the trademarks of their respective holders.

## Two- or Four-port Universal



## Interface Card for SYNC/570i (PCI)

Synchronous Communications Controller

## Installation Instructions

### Introduction

Digi's two- or four-port Universal Interface Card can automatically determine, from the cable, the interface bus type to use with the peripheral device. That is, you can select an interface type for the adapter (V.35, X.21, EIA-530, or EIA-232) just by connecting the appropriate cable between the peripheral device and the adapter for the two-port card or between the peripheral device and the quad-cable attached to the adapter for the four-port card. Each of the ports on the quad cable can use the same or a different type of interface cable, giving you the flexibility to use one adapter to connect to peripherals with different interface types.

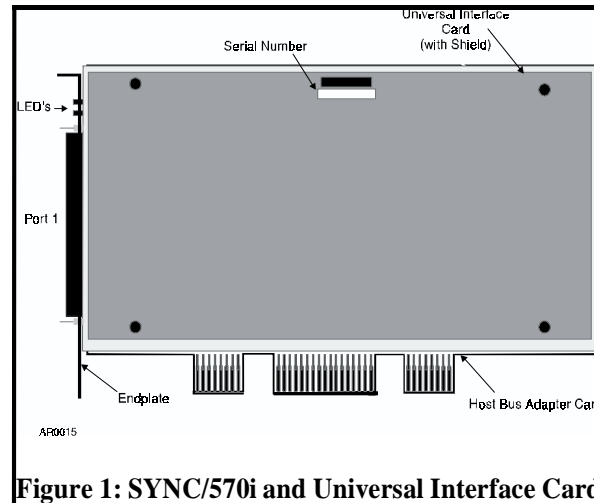

Figure 1: SYNC/570i and Universal Interface Card

## Installing the Adapter

### Before you begin

Before installing the SYNC/570i adapter and daughter card, you should do the following:

- Be sure that you have the correct cables for the interface type(s) you will use with the SYNC/570i. The cables shipped are dependent on which package is purchased. The four-port interface card may have up to four peripheral cables in addition to the quad-cable. **The quad-cable only ships with the four-port card** The two-port card may have up to two cables.
- Record the adapter's serial number (located under the part number label as shown in Figure 1), which will enable Digi to provide you with better service, should the need arise.
- Unplug power from the PC.
- Discharge static electricity from your body by touching a grounded surface (prior to handling the adapter).
- Put a ground strap on to ground yourself. (If one is not available, ground yourself by touching an unpainted metal surface, such as the computer's chassis.)

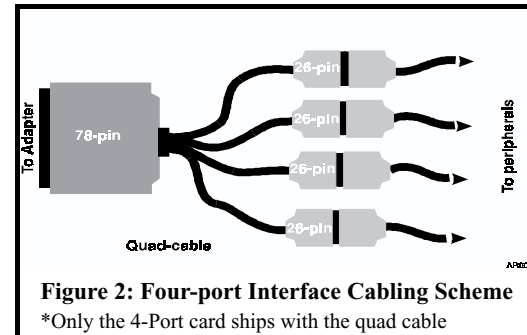

Figure 2: Four-port Interface Cabling Scheme

\*Only the 4-Port card ships with the quad cable

### Installation Procedure

- Install the adapter.
  - Remove the computer's cover.
  - Locate an available PCI slot in your computer and remove the slot plate.
  - Insert the adapter into the slot and screw the endplate to the computer chassis. The endplate

- must be screwed into the computer chassis to remain in compliance with Part 15 of FCC rules.
  - Replace the computer's cover.
- Connect cables. (See Figure 2 for quad cable.)
    - Attach the end of the quad-cable with the HDD 78-pin connector to the adapter port.
    - Attach peripheral cables to the HDD 26-pin connectors on the end of the quad cable. Because the HDD-26 end of the peripheral cables do *not* have a label, take care when making this connection. For example, both ends of the X.21 peripheral cable look similar. (You need not use all of the ports on the quadcable.)
    - Attach the other end of the peripheral cables to peripherals. (Additional cabling information is provided on this card.)
- Note: Two-port card - One end of each cable is labelled with the interface type. Attach that end to the peripheral. Attach the other end to an adapter port. (Additional cabling information is provided on this card.)

- Boot the computer.

Note: The LEDs showing through the faceplate on the adapter will not light until a driver is loaded and the adapter initialized. With the Digi driver loaded, the green LED will light to indicate that the adapter is in a "ready" state. The amber LED will light when data is passed to the peripheral device.

### What next?

Install and configure the software for the Digi SYNC/570i PCI Board.

### Usage Note

- If you change the interface of a port (by changing the interface cable) while your system is up, the new interface may not be recognized until the driver is restarted.

### If you have a problem

- If you have a problem booting your system after installation of your SYNC/570i adapter, you should call Technical Support for assistance.



PN:(1P) 90000542 A

## Cabling Information

The cables included with your adapter are designed with custom components and cannot be independently manufactured. If you require multiple peripheral cables of one type, you may order additional cables from Digi. To extend the length of a Digi cable, use standard interface cabling between the end of Digi's cable and the peripheral.

## Interface Pinouts

Each peripheral cable provided by Digi has a 26-pin HDD connector on one end, which attaches to a port on the quad-cable. The other end of the cable will provide signals according to the interface standards. The pinouts for each of the cables is provided next.

### EIA-232, Male DB-25 Connector

Pin	Description	Pin	Description
2	TXD	20	DTR
3	RXD	6	DSR
15	TXCIN	8	DCD
17	RXC	24	TXCOUT
4	RTS	22	RI
5	CTS	7	GND
1 and shell	CGND		

### V.35, Male 34-pin Connector

Pin	Description	Pin	Description
A	CGND	R	RXD(A)
B	GND	T	RXD(B)
C	RTS	U	TXCLKOUT(A)
D	CTS	W	TXCLKOUT(B)
E	DSR	V	RXCLK(A)
F	DCD	X	RXCLK(B)
H	DTR	Y	TXCLKIN(A)
P	TXD(A)	AA	TXCLKIN(B)
S	TXD(B)		

### X.21, Male DB-15 Connector

Pin	Description	Pin	Description
2	TXD(A)	12	Indicator(B)
9	TXD(B)	6	SETI(A)*
3	Control(A)	13	SETI(B)*
10	Control(B)	7	SETO(A)**
4	RXD(A)	14	SETO(B)**
11	RXD(B)	8	Signal Ground
5	Indicator(A)	1 and shell	CGND

\*SETI=Signal Element Timing In

\*\*SETO=Signal Element Timing Out

### EIA-530, Male DB-25 Connector

Pin	Description	Pin	Description
2	TXD(A)	13	CTS(B))
14	TXD(B)	20	DTE Ready(A)
3	RXD(A)	23	DTE Ready(B)
16	RXD(B)	6	DCE Ready(A)
15	TXCLKIN(A)	22	DCE Ready(B)
12	TXCLKIN(B)	8	RLSD(A)*
17	RXCLK(A)	10	RLSD(B)*
9	RXCLK(B)	24	TXCLKOUT(A)
4	RTS(A)	11	TXCLKOUT(B)
19	RTS(B)	7	Signal Ground
5	CTS(A)	1 and shell	CGND

\* RLSD=Received Line Signal Detector

## Regulatory Notices

### Federal Communications Commission (FCC) Statement

#### Radio Frequency Interference (RFI) (FCC 15.105)

This device has been tested and found to comply with the limits for Class B digital devices pursuant to Part 15 Subpart B, of the FCC Rules. These limits are designed to provide reasonable protection against harmful interference in a residential environment. This equipment generates, uses, and can radiate radio frequency energy, and if not installed and used in accordance with the instruction manual, may cause harmful interference to radio communications. However, there is no guarantee that interference will not occur in a particular installation. If this equipment does cause harmful interference to radio or television reception, which can be determined by turning the equipment off and on, the user is encouraged to try and correct the interference by one or more of the following measures:

- Reorient or relocate the receiving antenna.
- Increase the separation between the equipment and the receiver.
- Connect the equipment into an outlet on a circuit different from that to which the receiver is connected.
- Consult the dealer or an experienced radio/TV technician for help.

#### Labeling Requirements (FCC 15.19)

This device complies with Part 15 of FCC rules. Operation is subject to the following two conditions: (1) this device may not cause harmful interference, and (2) this device must accept any interference received, including interference that may cause undesired operation.

#### Modifications (FCC 15.21)

Changes or modifications to this equipment not expressly approved by Digi may void the user's authority to operate this equipment.

#### Declaration of Conformity

(In accordance with FCC Dockets 96-208 and 95-19)

<b>Manufacturer's Name:</b>	Digi International
<b>Corporate Headquarters:</b>	11001 Bren Road East Minnetonka MN 55343
<b>Manufacturing Headquarters:</b>	10000 West 76th Street Eden Prairie MN 55344

Digi International declares, that the product:

<b>Product Name:</b>	SYNC/570i PCI
<b>Model Numbers:</b>	50000830-01 and 50000830-02 used with 63000020-01

To which this declaration relates, meets the requirements specified by the Federal Communications Commission as detailed in the following specifications

- Part 15, Subpart B, for Class B Equipment
- FCC Docket 96-208 as it applies to Class B personal Computers and Peripherals

The product listed above has been tested at an External Test Laboratory

certified per FCC rules and has been found to meet the FCC, Part 15, Class B, Emission Limits. Documentation is on file and available from the Digi International Homologation Department.

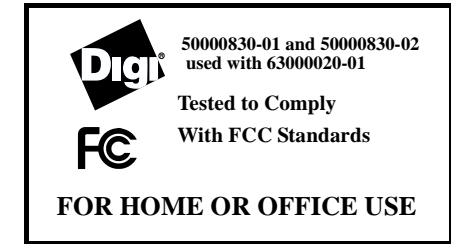

## Industry Canada

This Class B digital apparatus meets the requirements of the Canadian Interference Causing Equipment Regulations.

Cet appareil numérique de la classe B respecte toutes les exigences du Règlement sur le matériel brouilleur du Canada.

## European EMC Standards

This device meets the following electromagnetic emissions standards:

- EN55022
- EN50082-2

## European TTE Standard

This device meets the I-CTR2 standard.

# CE 168X

## Safety Standards

This device meets the following safety standards:

- UL 1950
- CSA 22.2 No. 950
- EN60950

Note: **CLASS 1 LED PRODUCT**  
Wavelength: 585nm, 569 nm  
Duration: arbitrary, may be continuous