



Connectware™

Digi AT Command Reference

For Digi Flex and Digi One IA
Modems

Copyright

The Digi logo is a registered trademark of Digi International. All other brand and product names are trademarks of their respective holders.

© Digi International Inc., 2002 All Rights Reserved. Information in this document is subject to change without notice and does not represent a commitment on the part of Digi International. Digi provides this document “as is”, without warranty of any kind, either expressed or implied, including, but not limited to, the implied warranties of fitness or merchantability for a particular purpose. Digi may make improvements and/or changes in this manual or in the product(s) and/or the program(s) described in this manual at any time. This product could include technical inaccuracies or typographical errors. Changes are periodically made to the information herein; these changes may be incorporated in new editions of the publication.

Corporate Headquarters

Digi International
11001 Bren Road East
Minnetonka, Minnesota 55343 USA
Phone: (952) 912-3444 or 877-912-3444
Fax: (952) 912-4952

Digi Technical Support

You must register your product to validate your warranty and receive your free 90 days of technical support! Please register on-line at <http://register.digi.com>.

If you encounter problems installing or using this product, your first line of support is to contact your solution provider for technical assistance.

For self help, visit the Digi support site at <http://support.digi.com> for drivers, firmware upgrades, cable information, documentation, FAQs, and knowledgebase articles.

Contents

Chapter 1 – Introduction	1
Overview.....	1
Command Syntax	1
Command Descriptions.....	1
Chapter 2 – Syntax and Procedures	2
Alphabet	2
DTE Commands Lines	2
Command Line General Format	2
Command Line Editing.....	3
Command Line Echo	3
Repeating a Command Line	3
Types of DTE Commands.....	3
Basic Syntax Commands	4
Basic Syntax Command Format	4
Parameters.....	4
Extended Syntax Commands.....	5
Command Naming Rules.....	5
Values	5
Action Commands.....	6
Parameter Commands.....	7
Additional Syntax Rules	8
Issuing Commands.....	9
Executing Commands	9
Aborting Commands	9
Handling of Invalid Numbers and S-Parameter Values	9
Modem Responses.....	10
Responses	10
Extended Syntax Result Codes	11
+<name>: <compound_value>Information Text Formats for Test Commands.....	11
Chapter 3 – Data Command Set	13
Command Guidelines	13
Escape Code Sequence	13
Data Commands.....	13
Generic Modem Control Commands	13
DTE-Modem Interface Commands	21
Call Control Commands.....	29
Modulation Control Commands	38
Error Control Commands.....	41
Data Compression Commands.....	46
V.8/V.8bis Commands	49
Diagnostic Commands.....	50
Compatibility Commands	55
FastConnect Commands	56
V.92 +P and –Q Commands.....	56
S-Parameters	60
Factory Defaults	60
S-Parameters Definitions	62
Result Codes	71

Chapter 4 – Fax Class 1 and Class 1.0 Commands	76
Fax I/O Processing	76
DTE-to-Modem Transmit Data Stream	76
Modem-to-DTE Receive Data Stream	76
Fax Mode Selection	77
Fax Origination.....	77
Fax Answering	77
Fax Control Transmission	77
Fax Control Reception	78
Fax Data Transmission	79
Fax Data Reception	79
Commands and Parameters	80
Mode Entry Commands	80
Mode Commands.....	80
Service Class 1 Parameters	83
Examples.....	87
Chapter 5 – Fax Class 2 Commands	89
Command and Syntax Guidelines.....	90
Mode Entry Commands	90
DTE Commands	90
Serial Port Speed and Flow Control	91
Auto Answer.....	92
Identification of T.30 Options	92
Session Status Reporting	92
Procedure Interrupt Negotiation.....	92
Service Class 2 Identification and Selection	93
Service Class 2 Action Commands	94
Service Class 2 DCE Responses.....	102
Service Class 2 Parameters	105
Example Sessions	109
Chapter 6 – Voice Commands	111
Voice Commands Overview	111
<DLE> Shielded Event Codes Sent to the DTE	112
<DLE> Shielded Codes Sent to the Modem (DCE).....	113
Voice Commands	114
Configuration Commands	114
Voice Commands.....	115
Speakerphone Commands	125

Chapter 1 – Introduction

Overview

This manual describes the host command and responses for the embedded modem.

The commands and responses are implemented in controller firmware for specific modem models. Additional configuration and implementation information is available in release notes and/or readme files that accompany product firmware release.

The descriptions in this manual apply to all commands and parameters that may be supported by different modem models.

Command Syntax

The fundamental DTE interface command syntax is described in Chapter 2.

Command Descriptions

Commands are grouped into the following categories:

Syntax and procedures Chapter 2

Data commands Chapter 3

Fax Class 1 and Fax Class 1.0 commands Chapter 5

Fax Class 2 commands Chapter 6

Voice/Audio commands Chapter 7

Chapter 2 – Syntax and Procedures

The command and response syntax and procedures generally conform to referenced recommendations and standards. Since these recommendations and standards describe characteristics universal to a large installed base of modems to a maximum degree, there may be syntax and procedural differences due to extensions and behavioral differences in implemented commands, parameters, and responses beyond that described in these recommendations and standards.

The syntax and procedures described in this section are based on V.250 and V.253 with additional information included for implemented extensions, behavioral differences beyond V.250, and legacy commands.

Alphabet

The T.50 International Alphabet 5 (IA5) is used in this document. Only the low-order seven bits of each character are significant to the modem; any eighth or higher-order bit(s), if present, are ignored for the purpose of identifying commands and parameters.

Lower-case characters are considered identical to their upper-case equivalents when received by the modem from the DTE. Result codes from the modem are in upper case.

DTE Commands Lines

Words enclosed in <angle brackets> are references to syntactical elements. The brackets are not used when the words appear in a command line, the brackets are not used. Words enclosed in [square brackets] represent optional items which may be omitted from the command line at the specified point. The square brackets are not used when the words appear in the command line. Other characters that appear in syntax descriptions must as included as shown.

Any modem responses are mentioned in terms of their alphabetic format; the actual response issued will depend on the setting of parameters that affect response formats, e.g., Q and V commands.

Command Line General Format

A command line is made up of three elements: the prefix, the body, and the termination character.

The command line prefix consists of the characters "AT" or "at" or, to repeat the execution of the previous command line, the characters "A/" or "a/".

The body is made up of individual commands described in this document. Space characters (IA5 2/0) are ignored and may be used freely for formatting purposes, unless they are embedded in numeric or string constants. The termination character may not appear in the body. The modem can accept at least 50 characters in the body.

The termination character may be selected by a user option (parameter S3), the default being CR.

Command Line Editing

The character defined by parameter S5 (default, BS) is interpreted as a request from the DTE to the modem to delete the previous character. Any control characters (IA5 0/0 through 1/15, inclusive) that remain in the command line after receipt of the termination character are ignored by the modem.

The modem checks characters from the DTE first to see if they match the termination character (S3), then the editing character (S5), before checking for other characters. This ensures that these characters will be properly recognized even if they are set to values that the modem uses for other purposes. If S3 and S5 are set to the same value, a matching character will be treated as matching S3 (S3 is checked before S5).

Command Line Echo

The modem may echo characters received from the DTE during command state and online command state back to the DTE, depending on the setting of the E command. If enabled, characters received from the DTE are echoed in the same format as received. Invalid characters in the command line or incomplete or improperly-formed command line prefixes may not be echoed.

Repeating a Command Line

If the prefix "A/" or "a/" is received, the modem immediately executes once again the body of the preceding command line. No editing is possible, and no termination character is necessary. A command line may be repeated multiple times in this manner. Responses to the repeated command line are issued using format of the original command line. If "A/" is received before any command line has been executed, the preceding command line is assumed to have been empty (that results in an OK result code).

Types of DTE Commands

There are two types of commands: action commands and parameter commands. Commands of either type may be included in command lines, in any order.

Action commands may be "executed" (to invoke a particular function of the equipment, which generally involves more than the simple storage of a value for later use), or "tested" (to determine whether or not the equipment implements the action command, and, if subparameters are associated with the action, the ranges of subparameter values that are supported).

Parameters may be "set" (to store a value or values for later use), "read" (to determine the current value or values stored), or "tested" (to determine whether or not the equipment implements the parameter, and the ranges of values supported).

Basic Syntax Commands

Basic Syntax Command Format

The format of Basic Syntax commands, except for the D and S commands, is as follows:

<command>[<number>]

where <command> is either a single character, or the "&" character followed by a single character per V.250. In addition, <command> can be the "%" character followed by a single character, the "*" character followed by a single character, or the "^" character followed by a single character.

<number> may be a string of one or more characters from "0" through "9" representing a decimal integer value. Commands that expect a <number> are noted in the description of the command. If a command expects <number> and it is missing (<command> is immediately followed in the command line by another <command> or the termination character), the value "0" is assumed. If a command does not expect a <number> and a number is present, an ERROR is generated. All leading "0"s in <number> are ignored by the modem.

Additional commands may follow a command (and associated parameter, if any) on the same command line without any character required for separation. The actions of some commands cause the remainder of the command line to be ignored (e.g., A).

See the D command for details on the format of the information that follows it.

Parameters

Commands that begin with the letter "S" are known as "S-parameters". The number following the "S" indicates the "parameter number" being referenced. If the number is not recognized as a valid parameter number, an ERROR result code is issued.

Immediately following this number, either a "?" or "=" character must appear. "?" is used to read the current value of the indicated S-parameter; "=" is used to set the S-parameter to a new value.

S<parameter_number>?
S<parameter_number>=[<value>]

If the "=" is used, the new value to be stored in the S-parameter is specified in decimal following the "=". If no value is given (i.e., the end of the command line occurs or the next command follows immediately), the S-parameter specified may be set to 0, or an ERROR result code issued and the stored value left unchanged. The ranges of acceptable values are given in the description of each S-parameter.

If the "?" is used, the modem transmits a single line of information text to the DTE. The text portion of this information text consists of exactly three characters, giving the value of the S-parameter in decimal, with leading zeroes included.

Extended Syntax Commands

Command Naming Rules

Both actions and parameters have names, which are used in the related commands. Names always begin with the character "+". Following the "+", from one to 16 additional characters appear in the command name. These characters will be selected from the following set:

A through Z	(IA5 4/1 through 5/10)
0 through 9	(IA5 3/0 through 3/9)
!	(IA5 2/1)
%	(IA5 2/5)
-	(IA5 2/13)
.	(IA5 2/14)
/	(IA5 2/15)
:	(IA5 3/10)
—	(IA5 5/15)

The first character following the "+" is an alphabetic character in the range of "A" through "Z". This first character generally implies the application in which a command is used (e.g., F for Fax or V for voice). The modem considers lower-case characters to be the same as their upper-case equivalents.

Values

When subparameters are associated with the execution of an action, or when setting a parameter, the command may include specification of values. This is indicated by the appearance of <value> in the descriptions below.

<value> consists of either a numeric constant or a string constant.

Numeric Constants

Numeric constants are expressed in decimal, hexadecimal, or binary.

Decimal numeric constants consist of a sequence of one or more of the characters "0" through "9", inclusive.

Hexadecimal numeric constants consist of a sequence of one or more of the characters "0" through "9", inclusive, and "A" through "F" inclusive. The characters "A" through "F" represent the equivalent decimal values 10 through 15.

Binary numeric constants consist of a sequence of one or more of the characters "0" and "1".

In all numeric constants, the most significant digit is specified first. Leading "0" characters are ignored by the modem. No spaces, hyphens, periods, commas, parentheses, or other generally-accepted numeric formatting characters are permitted in numeric constants; note in particular that no "H" suffix is appended to the end of hexadecimal constants.

String Constants

String constants consist of a sequence of displayable IA5 characters, each in the range from 2/0 to 7/15, inclusive, except for the characters "" (IA5 2/2) and "\" (IA5 5/12). String constants are bounded at the beginning and end by the double-quote character ("", IA5 2/2).

Any character value may be included in the string by representing it as a backslash ("\") character followed by two hexadecimal digits. For example, "\0D" is a string consisting of the single character <CR> (IA5 0/13). If the "\" character itself is to be represented in a string, it is encoded as "\5C". The double-quote character, used as the beginning and ending string delimiter, is represented within a string constant as "\22".

A "null" string constant, or a string constant of zero length, is represented by two adjacent delimiters ("").

Compound Values

Actions may have more than one subparameter associated with them, and parameters may have more than one value. These are known as "compound values", and their treatment is the same in both actions and parameters.

A compound value consists of any combination of numeric and string values (as defined in the description of the action or parameter). The comma character must be included as a separator, before the second and all subsequent values in the compound value. If a value is not specified (i.e., defaults assumed), the required comma separator must be specified; however, trailing comma characters may be omitted if all associated values are also omitted.

Action Commands

Action Execution Command Syntax

There are two general types of action commands: those that have associated subparameter values that affect only that invocation of the command, and those that have no subparameters.

If subparameters are associated with a command, the definition of the action command indicates, for each subparameter, whether the specification of a value for that subparameter is mandatory or optional. For optional subparameters, the definition indicates the assumed (default) value for the subparameter if no value is specified for that subparameter; the assumed value may be either a previous value (i.e., the value of an omitted subparameter remains the same as the previous invocation of the same command, or is determined by a separate parameter or other mechanism), or a fixed value (e.g., the value of an omitted subparameter is assumed to be zero). Generally, the default value for numeric subparameters is 0, and the default value for string subparameters is "" (empty string).

The following syntax is used for actions that have no subparameters:

```
+<name>.
```

The following syntax is used for actions that have one subparameter:

```
+<name>[=<value>]
```

The following syntax is used for actions that have two or more subparameters:

```
+<name>[=<compound_value>]
```

For actions that accept subparameters, if all subparameters are defined as being optional, and the default values for all subparameters are satisfactory, the data terminal equipment (DTE) may use the first syntax above (i.e., omit the "=" from the action execution command as well as all of the subparameter value string).

If all other relevant criteria are met (e.g., the modem is in the proper state), the command is executed with any indicated subparameters. If <name> is not recognized, the modem issues the ERROR result code and terminates processing of the command line. An ERROR is also generated if a subparameter is specified for an action that does not accept subparameters, if too many subparameters are specified, if a mandatory subparameter is not specified, if a value is specified of the wrong type, or if a value is specified that is not within the supported range.

Action Test Command Syntax

The DTE may test if an action command is implemented in the modem by using the syntax:

```
+<name>=?
```

If the modem does not recognize the indicated name, it returns an ERROR result code and terminates processing of the command line. If the modem does recognize the action name, it returns an OK result code. If the named action accepts one or more subparameters, the modem sends an information text response to the DTE, prior to the OK result code, specifying the values supported by the modem for each such subparameter, and possibly additional information. The format of this information text is defined for each action command.

Parameter Commands

Parameter Types

Parameters may be defined as "read-only" or "read-write". "Read-only" parameters are used to provide status or identifying information to the DTE, but cannot be set by the DTE; attempting to set their value is an error. In some cases (specified in the description of the individual parameter), the modem may ignore attempts to set the value of such parameters rather than respond with an ERROR result code, if the continued correct operation of the interface between the modem and DTE will not be affected by such action. Read-only parameters may be read and tested.

"Read-write" parameters may be set by the DTE, to store a value or values for later use. Read-write parameters may be set, read, and tested.

Parameters may take either a single value, or multiple (compound) values. Each value may be either numeric or string; the definition of the parameter will specify the type of value for each subparameter. Attempting to store a string value in a numeric parameter, or a numeric value in a string parameter, is an error.

Parameter Set Command Syntax

The definition of the parameter indicates, for each value, whether the specification of that value is mandatory or optional. For optional values, the definition indicates the assumed (default) value if none is specified; the assumed value may be either a previous value (i.e., the value of an omitted subparameter retains its previous value), or a fixed value (e.g., the value of an omitted subparameter is assumed to be zero). Generally, the default value for numeric parameters is 0, and the default value for string parameters is "" (empty string).

The following syntax is used for parameters that accept a single value:

```
+<name>=<value>]
```

The following syntax is used for parameters that accept more than one value:

```
+<name>=<compound_value>]
```

For each implemented parameter, if all mandatory values are specified, and all values are valid according to the definition of the parameter, the specified values are stored. If <name> is not recognized, one or more mandatory values are omitted, or one or more values are of the wrong type or outside the permitted range, the modem issues the ERROR result code and terminates processing of the command line. An ERROR is also generated if too many values are specified. In case of an error, all previous values of the parameter are unaffected.

Parameter Read Command Syntax

The DTE may determine the current value or values stored in a parameter by using the following syntax:

+<name>?

The modem responds by sending the current values stored for the parameter to the DTE in an information text response. The format of this response is described in the definition of the parameter. Generally, the values are sent in the same form in which they would be issued by the DTE in a parameter setting command; if multiple values are supported, they will generally be separated by commas, as in a parameter setting command.

Parameter Test Command Syntax

The DTE may test if a parameter is implemented in the modem, and determine the supported values, by using the syntax:

+<name>=?

If the modem does not recognize the indicated name, it returns an ERROR result code and terminates processing of the command line. If the modem does recognize the parameter name, it returns an information text response to the DTE, followed by an OK result code. The information text response indicates the values supported by the modem for each such subparameter, and possibly additional information. The format of this information text is defined for each parameter.

Additional Syntax Rules

Concatenating Commands after Extended Syntax Commands

Additional commands may follow an extended-syntax command on the same command line if a semicolon (";") is inserted after the preceding extended command as a separator. The semicolon is not necessary when the extended syntax command is the last command on the command line.

Concatenating Commands after Basic Format Commands

Extended syntax commands may appear on the same command line after a basic syntax command without a separator, in the same manner as concatenation of basic syntax commands.

Issuing Commands

All characters in a command line must be issued at the same data rate, and with the same parity and format.

The modem will ignore any command line that is not properly terminated. The modem may consider 30 seconds of mark idle time between any two characters as an improperly terminated command line. In this case the modem may or may not generate an ERROR message. The modem will ignore any characters received from the DTE that are not part of a properly-formatted command line.

If the maximum number of characters that the modem can accept in the body is exceeded, an ERROR result code is generated after the command line is terminated.

The DTE will not begin issuing a subsequent command line until at least one-tenth of a second has elapsed after receipt of the entire result code issued by the modem in response to the preceding command line.

Executing Commands

Upon receipt of the termination character, the modem commences execution of the commands in the command line in the order received from the DTE. Should execution of a command result in an error, or a character be not recognized as a valid command, execution is terminated, the remainder of the command line is ignored, and the ERROR result code is issued. Otherwise, if all commands execute correctly, only the result code associated with the last command is issued; result codes for preceding commands are suppressed. If no commands appear in the command line, the OK result code is issued.

Aborting Commands

Some action commands that require time to execute may be aborted while in progress; these are explicitly noted in the description of the command. Aborting of commands is accomplished by the transmission from the DTE to the modem of any character. A single character is sufficient to abort the command in progress; however, characters transmitted during the first 125 milliseconds after transmission of the termination character are ignored (to allow for the DTE to append additional control characters such as line feed after the command line termination character). **To ensure that the aborting character is recognized by the modem, it should be sent at the same rate as the preceding command line; the modem may ignore characters sent at other rates.** When such an aborting event is recognized by the modem, the modem terminates the command in progress and returns an appropriate result code to the DTE, as specified for the particular command.

Handling of Invalid Numbers and S-Parameter Values

The modem reacts to undefined numbers and S-parameter values in one of three ways:

1. Issue the ERROR result code, and leave the previous value of the parameter unchanged;
2. Issue the OK result code, and leave the previous value of the parameter unchanged; or,
3. Issue the OK result code, and set the parameter value to the valid value nearest to that specified in the command line.

The description of each command specifies which of these three techniques is used to handle invalid parameter values for that command or parameter.

Modem Responses

While in command state and online command state, the modem will issue responses using the same rate, word length, and parity as the most recently received DTE command line. In the event that no DTE command has yet been received, rate, word length, and parity used will depend on the capabilities of the modem.

When the modem transitions from the command state or online command state to the online data state, the result code **CONNECT** should be issued at the bit rate and parity used during the command state. When the modem transitions from the online data state to the command state or online command state, the result codes should be issued at the bit rate used during the online data state. Thereafter, any unsolicited result codes should use the bit rate and parity of the last command line issued by the DTE to the modem.

The characters of a response will be contiguous, with no more than 100 milliseconds of mark idle issued between characters in addition to stop elements.

Responses

There are two types of responses that may be issued by the modem: information text and result codes.

Information Text. Information text responses consist of three parts: a header, information text, and a trailer:

1. The characters transmitted for the header are determined by the V command.
2. The trailer consists of two characters, being the character having the ordinal value of parameter S3 followed by the character having the ordinal value of parameter S4.
3. Information text usually consists of a single line; information text returned in response to some commands may contain multiple lines, and the text may therefore include CR, LF, and other formatting characters to improve readability.

Result Code Parts. Result codes consist of three parts: a header, the result text, and a trailer.

1. The characters transmitted for the header and trailer are determined by the V command setting.
2. The result text may be transmitted as a number or as a string, also depending on a the V command setting..

Result Code Types. There are three types of result codes: final, intermediate, and unsolicited.

1. A final result code indicates the completion of a full modem action and an ability to accept new commands from the DTE.
2. An intermediate result code is a report of the progress of an modem action. The **CONNECT** result code is an intermediate result code. In the case of a dialing or answering command, the modem switches from command state to online data state, and issues a **CONNECT** result code. This is an intermediate result code for the modem because it cannot accept commands from the DTE while in online data state. When the modem switches back to the command state it then issues a final result code (such as **OK** or **NO CARRIER**).
3. Unsolicited result codes (such as **RING**) indicate the occurrence of an event not directly associated with the issuance of a command from the DTE.

Extended Syntax Result Codes

Extended syntax result codes may be issued in response to either basic or extended commands, or both. The appropriate responses are specified in the definitions of the commands, the responses, or both.

The general format of extended syntax result codes is the same as result codes defined in TIA-602 with regard to headers and trailers. The characters specified in S-parameters S3 and S4 are used in headers and trailers of extended syntax result codes as they are in basic format result codes. The setting of the V command affects the headers and trailers associated with extended syntax result codes in the same manner as basic format result codes; however, unlike basic format result codes, extended syntax result codes have no numeric equivalent, and are always issued in alphabetic form.

Extended syntax result codes are subject to suppression by the Q1 command, as with basic format result codes. The issuance of extended syntax result codes are not be affected by the setting of the X command.

Extended syntax result codes may be either final, intermediate, or unsolicited; the type being indicated in the definition of the result code.

Extended syntax result codes are prefixed by the "+" character to avoid duplication of basic format result codes specified in TIA-602. Following the "+" character, the name of the result code appears; result code names follow the same rules as command names.

Extended syntax result codes may include the reporting of values. The definition of the result code specifies whether or not values are appended to the result code, and, if so, how many, their types, and their assumed default values if omitted.

Data/voice Modes. When no values are to be reported, the result code appears in the simplest form:

+<name>

If a single value is to be reported, the form of the result code is:

+<name>: <value>

A single space character separates the colon character from the <value>; no space appears between the result code name and the colon. If multiple values are to be reported with the result code, the form is:

+<name>: <compound_value>

Fax Modes. If a single value is to be reported, the form of the result code is:

<value> or (<value>)

+<name>: <compound_value>Information Text Formats for Test Commands

In general, the format of information text returned by extended syntax commands is described in the definition of the command.

The modem may insert intermediate <CR> characters in very long information text responses in order to avoid overrunning DTE receive buffers. If intermediate <CR> characters are included, the modem does not include the character sequences "0 <CR>" or "OK<CR>", so that DTE can avoid false detection of the end of these information text responses.

Range of Values

When the action accepts a single numeric subparameter, or the parameter accepts only one numeric value, the set of supported values may be presented in the information text as an ordered list of values. The list is preceded by a left parenthesis ((), and is followed by a right parenthesis ()). If only a single value is supported, it appears between the parentheses. If more than one value is supported, then the values may be listed individually, separated by comma characters, or, when a continuous range of values is supported, by the first value in the range, followed by a hyphen character (-), followed by the last value in the range. The specification of single values and ranges of values may be intermixed within a single information text. In all cases, the supported values are indicated in ascending order.

For example, the following are some examples of value range indications:

(0)	Only the value 0 is supported.
(1,2,3)	The values 1, 2, and 3 are supported.
(1-3)	The values 1 through 3 are supported.
(0,4,5,6,9,11,12)	The several listed values are supported.
(0,4-6,9,11-12)	An alternative expression of the above list.

Compound Range of Values

When the action accepts more than one subparameter, or the parameter accepts more than one value, the set of supported values is presented as a list of the parenthetically-enclosed value range strings described above, separated by commas. For example, the information text in response to testing an action that accepts three subparameters, and supports various ranges for each of them, could appear as follows:

(0),(1-3),(0,4-6,9,11-12)

This indicates that the first subparameter accepts only the value 0, the second accepts any value from 1 through 3 inclusive, and the third subparameter accepts any of the values 0, 4, 5, 6, 9, 11, or 12.

Chapter 3 – Data Command Set

Command Guidelines

The commands used to control and report modem operation in data modem mode are defined in this section.

The Data Modem Mode commands and responses described in this section are applicable when command +FCLASS=0.

The default values are typical of a fully configured modem supporting all data rates and options. The actual default value is dependent upon installed modem firmware and country specific parameters.

Commands are accepted by the modem once the previous command has been fully executed, which is normally indicated by the return of an appropriate result code. Execution of commands D and A, either as a result of a direct command or a re-execute command, will be aborted if another character is entered before completion of the handshake.

Escape Code Sequence

When the modem has established a connection and has entered on-line data mode, it is possible to break into the data transmission in order to issue further commands to the modem in an on-line command mode. This is achieved by the DTE sending to the modem a sequence of three ASCII characters specified by register S2. The default character is '+'. The maximum time allowed between receipt of the last character of the three escape character sequence from the DTE and sending of the OK result code to the DTE is controlled by the S12 register.

Data Commands

The modem will respond to the commands detailed below. Parameters applicable to each command are listed with the command description. The defaults shown for each configuration command are those used in the Conexant factory profile 0.

Generic Modem Control Commands

Command:	Z	Soft Reset and Restore Profile
Description:		This command causes the modem to perform a soft reset and restore (recall) the configuration profile. If no <value> is specified, zero is assumed.
Syntax:		Z<value>
Defined Values:		<value> Decimal number corresponding to the selected profile. 0 Soft reset and restore stored profile 0. 1 Soft reset and restore stored profile 1.
Result Codes:		OK <value> = 0 or 1. ERROR Otherwise.

Command: +FCLASS Select Active Service Class

Description: This command selects the active service class (mode).
 Syntax: +FCLASS=<mode>
 Defined Values: <mode> Decimal number which corresponds to the selected service class.
 0 Select Data Mode (Section 3). (Default.)
 1 Select Facsimile Class 1 Mode.
 1.0 Select Facsimile Class 1.0 Mode.
 2 Select Facsimile Class 2 Mode.
 8 Select Voice Mode.
 10 Reserved.

Result Codes: OK For <mode> = 0, 1, 1.0, 2, 8, and 10 (SC only).
 OK For <mode> = 0, 1, 1.0, 8, and 10 (other than SC).
 ERROR Otherwise

Reporting Current or Selected Values: Command: +FCLASS?
 Response: +FCLASS: <mode>
 Example: +FCLASS: 0 For the default setting.

Reporting Supported Range of Parameter Values: Command: +FCLASS=?
 Response: +FCLASS: (<mode> range)
 Example: +FCLASS: (0,1,1.0,2,8,10)

Command: +VCID Caller ID (CID)

Description: This command controls the reporting and presentation of data associated with the Caller ID services in the Incoming Call Line ID (ICLID) data format for the next call.
 Syntax: +VCID=<pmode>
 Defined Values: <pmode> Decimal number corresponding to the selected option.
 0 Disable Caller ID reporting. (Default.)
 1 Enables Caller ID with formatted presentation to the DTE. The modem presents the data items in a <Tag><Value> pair format. The expected pairs are date, time, name, and caller code (telephone number),
 2 Enables Caller ID with unformatted presentation to the DTE.

Reporting Current or Selected Values: Command: +VCID?
 Response: +VCID: <pmode>
 Example: +VCID: 0 For the default setting.

Reporting Supported Range of Parameter Values: Command: +VCID=?
 Response: +VCID: (<pmode> range)
 Example: +VCID: (0-2)

Command: +VRID Report Retrieved Caller ID (CID)

Description: This command reports the data associated with the Caller ID services in the Incoming Call Line ID (ICLID) data format for the last received call.
 Syntax: +VRID=<pmode>
 Defined Values: <pmode> Decimal number corresponding to the selected option.
 0 Reports Caller ID with formatted presentation to the DTE. The modem presents the data items in a <Tag><Value> pair format. The expected pairs are date, time, name, and caller code (telephone number).
 1 Reports Caller ID with unformatted presentation to the DTE.

Reporting Supported Range of Parameter Values: Command: +VRID=?
 Response: +VRID: (<pmode> range)
 Example: +VRID: (0,1)

Command: \N**Operating Mode**

Description:	This command controls the preferred error correcting mode to be negotiated in a subsequent data connection. This command is affected by the OEM firmware configuration.
Syntax:	\N<mode>
Defined Values:	<mode> Decimal number which corresponds to the selected mode. 0 Selects normal speed buffered mode (disables error-correction mode). (Forces &Q6.) 1 Serial interface selected - Selects direct mode and is equivalent to &M0, Q0 mode of operation. (Forces &Q0.) Parallel interface selected - Same as \N0. 2 Selects reliable (error-correction) mode. The modem will first attempt a LAPM connection and then an MNP connection. Failure to make a reliable connection results in the modem hanging up. (Forces &Q5, S36=4, and S48=7.) 3 Selects auto reliable mode. This operates the same as \N2 except failure to make a reliable connection results in the modem falling back to the speed buffered normal mode. (Forces &Q5, S36=7, and S48=7.) 4 Selects LAPM error-correction mode. Failure to make an LAPM error-correction connection results in the modem hanging up. (Forces &Q5 and S48=0.) Note: The -K1 command can override the \N4 command. 5 Selects MNP error-correction mode. Failure to make an MNP error-correction connection results in the modem hanging up. (Forces &Q5, S36=4, and S48=128.)
Result Codes:	OK <mode> = 0 to 5. ERROR Otherwise.

Command I**Identification**

Description:	This command causes the modem to reports the requested result according to the command parameter.
Syntax:	I<value>
Defined Values:	<value> Decimal number corresponding to the selected information. 0 Reports product code, e.g., "56000". 1 Reports the least significant byte of the stored checksum in decimal. Reports 255 if the prestored checksum value is FFh. 2 Reports "OK". 3 Reports identification codes. For the SmartACFL, SmartACF, and SC56D, the codes are in the form RevisionName-Modulation_Model, where: RevisionName = product family name_firmware version, i.e., ACF3. The firmware version is in the form VX.XXX. Example: ACF3_V1.000 Modulation = V90, V34, or V32 for V.92/V.90, V.34, or V.32bis, respectively. Model = Identifies RAM/ROM configuration. For the SmartSCM, the codes are in the form RevisionName-Modulation, where: RevisionName = masked firmware code version. Example: P2109 Modulation = V90, V34, or V32 for V.90, V.34, or V.32bis, respectively. Examples: ACF3_V1.000-V90_P21_FSH P2109-V90 Note: If RPI+ is enabled (see +Hn), "ROCKWELL RPI (TM) MODEM+01" is appended. 4 Reports OEM defined identifier string in binary format (default) or ASCII format, e.g.: a007040284C6002F bC60000000 r1005111151012000 3000111170000000 5 Reports Country Code parameter (see +GCI). 6 Reports modem data pump model and internal code revision. Example: "RCV56DPF-PLL L8773A Rev 14.00/34.00". 7 Reports "OK".
Result Codes:	OK <value> = 0 - 7. ERROR Otherwise.

Command:	+GMI	Request Manufacturer Identification
Description:		This command causes the modem to report the modem product manufacturer.
Syntax:		+GMI
Typical Response:		+GMI: CONEXANT OK
Command:	+GMI9	Request Conexant Identification
Description:		This command causes the modem to report CONEXANT ACF identification.
Syntax:		+GMI9
Response:		+GMI9: CONEXANT ACF OK
Command	+GMM	Request Model Identification
Description:		This command causes the modem to report the modem product.
Syntax:		+GMM
Typical Response:		+GMM: V90
Command:	+GMR	Request Revision Identification
Description:		This command causes the modem to report the modem version, revision level or date. This is the same as the I3 command.
Syntax:		+GMR
Typical Response:		+GMR: P2109-V90 OK
Command:	+GCAP	Request Complete Capabilities List
Description:		This extended-format command causes the modem to transmit one or more lines of information text listing additional capabilities command +<name>s , which is intended to permit the user to identify the overall capabilities of the modem. In particular, if the modem implements a particular modem control standard that uses Extended Syntax Commands, and if that modem control standard includes command(s) that indicate general capabilities, the +<names>(s) of those commands will be reported to the modem in response to a +GCAP command.
Syntax:		+GCAP
Example Responses:		+GCAP: +FCLASS, +MS, +ES, +DS, for a data modem that supports all capabilities listed Where: +FCLASS T.class1, +F (Class 1 Facsimile modem Control) +MS +M commands (Modulation Control: +MS and +MR commands) +ES +E commands (Error Control: +ES, +EB, +ER, +EFCS, +ETBM) +DS +D commands (Data Compression: +DS and +DR).AT Commands Reference Manual

Command: +GCI Country of Installation

Description: This extended syntax command selects and indicates the country of installation for the modem. This parameter selects the settings for any operational parameters that need to be adjusted for national regulations or telephone networks.

Syntax: +GCI=<country_code>

Defined Values: <country_code> 8-bit country code from Annex A of T.35. The value is the hexadecimal equivalent of the T.35 code, with bit 8 treated as the most significant bit and bit 1 treated as the least significant bit.

The supported countries are:

Country	Code	Country	Code	Country	Code
Australia	09	Hong Kong	50	Norway	82
Austria	0A	Hungary	51	Philippines	89
Belgium	0F	India	53	Poland	8A
Brazil	16	Ireland	57	Portugal	8B
Bulgaria	1B	Israel	58	Russia	B8
Canada	20	Italy	59	Singapore	9C
China	26	Japan	00	South Africa	9F
Czech and Slovak Federal Republic	2E	Korea	61	Spain	A0
Denmark	31	Luxembourg	69	Sweden	A5
Finland	3C	Malaysia	6C	Switzerland	A6
France	3D	Mexico	73	Taiwan	FE
Germany	42	Netherlands	7B	United Kingdom	B4
Greece	46	New Zealand	7E	United States	B5

Default: If the modem is specified for use in only one country, that country code is the default. Otherwise, the default is defined by the OEM. Factory default is B5 (United States).

Reporting Current or Selected Values: Command: +GCI?
Response: +GCI: <current country_code>
Example: +GCI: 3D The modem is set for France.

Reporting Supported Range of Parameter Values: Command: +GCI=?
Response: +GCI: (<country_code>[,<country_code>[,<country_code>].....])
Example: +GCI: (20,73,B5) The modem can be set for Canada, Mexico or the United States

Command: &F Restore Factory Configuration (Profile)

Description: The modem loads the factory default configuration (profile). The factory defaults are identified for each command and in the S-Parameter descriptions. A configuration (profile) consists of a subset of S-Parameters.

Syntax: &F[<value>]

Defined Values: <value> Decimal number corresponding to the selected configuration.
0 Restore factory configuration 0.
1 Restore factory configuration 1.

Result Codes: OK
ERROR If the modem is connected.

Command: &T Local Analog Loopback Test

Description: The modem will perform the local analog loopback test if &T1 is selected. The test can be run only when in an asynchronous operation in non-error-correction mode (normal), e.g., AT&Q6. To terminate the test in progress, the escape sequence must be entered first.

Syntax: &T[<value>]

Defined Values: <value> Decimal number corresponding to the selected option.
0 Terminates test in progress. Clears S16.
1 Initiates local analog loopback, V.54 Loop 3.

Sets S16 bit 0. If a connection exists when this command is issued, the modem hangs up. The CONNECT XXXX message is displayed upon the start of the test.

Command:	&Y	Designate a Default Reset Profile
Description:		This command selects which user profile will be used after a hard reset.
Syntax:		&Y<value>
Defined Values:		<value> Decimal number corresponding to the selected profile. 0 The modem will use profile 0. 1 The modem will use profile 1.
Result Codes:		OK <value> = 0 to 1. ERROR If <value> > 1, or if NVRAM is not installed or is not operational.
Command:	&W	Store Current Configuration
Description:		Saves the current (active) configuration (profile), including S-Parameters, in one of the two user profiles in NVRAM as denoted by the parameter value. This command will yield an ERROR message if the NVRAM is not installed or is not operational as detected by the NVRAM test. The current configuration is comprised of a list of storable parameters illustrated in the &V command. These settings are restored to the active configuration upon receiving a Zn command or at power up (see &Yn command).
Syntax:		&W<value>
Defined Values:		<value> Decimal number corresponding to the selected profile. 0 Store the current configuration as profile 0. 1 Store the current configuration as profile 1.
Result Codes:		OK <value> = 0 or 1. ERROR Otherwise.
Command	&Zn=x	Store Telephone Number
Description:		The modem can store up to four telephone numbers and each telephone number dial string can contain up to 31 digits. (Requires 256-byte NVRAM installed.)
Syntax:		&Z<value>
Defined Values:		<value> Decimal number from 0 to 3 corresponding to the selected telephone number. <string> Dial string from 0 to 31 characters.
Result Codes:		OK For <value> =3, and <string> =31 digits. ERROR If <value> > 3, <string> > 31 digits, or if NVRAM is not installed or is not operational.
Command	%7	Plug and Play Serial Number
Description:		Sets and stores eight serial numbers in hex format used for serial Plug and Play and for ISA Plug and Play which use the Conexant 11596 Plug and Play device. Applicable to Desktop configuration only.
Syntax:		%7<8 hex numbers><same 8 hex numbers>
Example:		%7<8 hex numbers><same 8 hex numbers>
Result Codes:		OK <8 hex numbers><same 8 hex numbers> ERROR Otherwise To display the stored serial number, issue AT"?<cr>.
Command	%8	Plug and Play Vendor ID and Product Number
Description:		Sets and stores Vendor ID and product number for serial Plug and Play and for ISA Plug and Play which use the Conexant 11596 Plug and Play device. Applicable to Desktop configuration only.
Syntax:		&8<3 ASCII characters><4 hex numbers><same 3 ASCII characters><same 4 hex numbers><cr>
Example:		%8<3 ASCII characters><4 hex numbers><same 3 ASCII characters><same 4 hex numbers><cr>
Result Codes:		OK <3 ASCII characters><4 hex numbers><same 3 ASCII characters><same 4 hex numbers> ERROR Otherwise

Command ** Load Flash Memory

Description: The linear flash memory uploader allows flash memory connected to the modem external memory bus to be upgraded with revised modem firmware. This process transfers (uploads) the upgraded modem firmware (data) from the host computer to the modem which transfers the data to the flash memory device. The linear flash memory downloader allows the flash memory connected to the modem external memory bus to read and saved. This process transfers (downloads) the current modem firmware (data) to the host computer. Uploading new firmware to the flash memory or downloading existing firmware from the flash memory device is a two-step process.

1. When the AT** command is issued, the modem firmware boot loader is invoked and the user will first load a flash load module (FLM) into the modem's RAM. If the user wishes to upload new firmware to the modem, he should load the uploader FLM. If the user wishes to download existing firmware from the modem, he should load the downloader FLM. In either case, the data transfer is done via an ASCII transfer. The FLM contains the programming algorithm for the flash memory device being programmed and any messages that may be sent during the load process.
2. If the user wishes to upload new firmware to the modem, then he will then load the new modem firmware, which the uploader FLM will then program into the flash memory device. This transfer is done via XMODEM transfer. If the user wishes to download existing firmware from the modem, then he will set up the host PC for XMODEM receive and the downloader FLM will begin to send the existing firmware from the flash memory to the host PC.

Procedure

1. Install in the modem a flash memory programmed with the modem firmware or a blank flash memory.
2. Put the uploader FLM and downloader FLM files and the new modem firmware file (e.g., XmUL003.s37, XmDL003.s37, and 206s4712.S37) in an appropriate directory on the computer's hard disk.
3. Configure the communications application program for a DTE rate of between 9600 bps and 115200 bps and RTS/CTS flow control.
4. Check the modem for response by typing AT.
5. Initiate the download process using the AT** command. The "Download flash code..." message appears upon issuing the AT** command.
6. Perform an ASCII transfer of the FLM file (e.g., XmUL003.s37 for uploading new firmware to the modem or XmDL003.s37 for downloading existing firmware from the modem) from the host computer to the modem RAM using an industry standard communications software or an equivalent process (ensure that all ASCII translation or pacing is turned off).
7. After the FLM has been loaded, if uploading new firmware to the modem, perform an XMODEM upload of the new modem firmware hex file (e.g., 206s4712.S37) from the host computer to the modem RAM using industry standard communications software or an equivalent process. If downloading existing firmware from the modem, using an industry standard communications software or equivalent, put the host PC in XMODEM receive mode.
8. The messages described in Table 3-1 may occur during the uploading process:

Table 3-1. Upload Messages

Message	Description
Device not supported	Displayed if the FLM used does not support the flash memory that is installed on the board.
Wrong S37 format	Displayed if the modem firmware being uploaded is not in Motorola S3 format.
Record error	Displayed if there is an error while either uploading or downloading. If this occurs, the transfer should be aborted, and the user should restart at step 5.
Download abort	Displayed if the transfer is aborted before it is finished. If this occurs, the user should restart at step 5.
Erase fail	Displayed if the FLM is unable to erase the flash memory. If this occurs, the user should restart at step 5.
Download error, Re-Load	Displayed if there was an error when uploading or downloading. If this occurs, the user should restart at step 5.
Error, No H/W flow ctl	Displayed if RTS-CTS flow control is not set. If this occurs, the user should restart at step 3.
DTE timeout	Displayed if the DTE has stopped the XMODEM transfer process before it is finished. If this occurs, the user should restart at step 5.
Code doesn't match Hardware	Displayed if the user is attempting to upload a firmware that either not the same model (parallel, serial, etc.), crystal frequency, or size (1Mbit, 2Mbit, etc.) as the firmware that is currently on the board. If

	this occurs, the FLM will abort and not allow the user to continue.
Device successfully Programmed	Displayed by the FLM at the completion of a successful upload or download then the modem will do a cold start.

The uploader and downloader flash load modules (FLM) have several built in safety mechanisms to reduce the risk of a failed flash upload/download. The FLM will not allow a user to upload a firmware of different model (serial, parallel, etc.) or crystal speed than what is currently in the flash memory. Also, it will not allow the user to upload a firmware that is larger in size than the flash memory itself (e.g., a 2Mbit firmware onto a 1Mbit flash memory). It will, however, allow the user to upload a firmware that is smaller in size than the flash memory, and it will program the firmware with the appropriate offset in order for the firmware to function properly. In the instance that there is a failure during the download or upload process, the modem will be in a “flash rescue mode”. In this mode, the modem will respond “OK” to all AT commands, but will only take action on the AT** command, so a new attempt to upload or download can be initiated. When the modem is in the “flash rescue mode” it will only be able to respond to AT commands if the DTE rate has not been changed since the last AT** command was successfully issued, even if the modem is powered off and on.

DTE-Modem Interface Commands

The parameters defined in this section control the operation of the interface between the DTE and modem.

Command: E

Description:

Syntax:

Defined Values:

Result Codes:

Command Echo

The modem enables or disables the echo of characters to the DTE. The parameter value, if valid, is written to S14 bit 1.

E<value>

<value> Decimal number corresponding to the option.

0 Disables command echo.

1 Enables command echo. (Default.)

OK <value> = 0 or 1.

ERROR Otherwise.

Command: Q

Description:

Syntax:

Defined Values:

Result Codes:

Quiet Results Codes Control

The command enables or disables the sending of result codes to the DTE. The parameter value, if valid, is written to S14 bit 2.

Q<value>

<value> Decimal number corresponding to the option.

0 Enables result codes to the DTE. (Default.)

1 Disables result codes to the DTE.

OK <value>= 0 or 1.

ERROR Otherwise.

Command: V

Description:

Syntax:

Defined Values:

Result Codes:

Result Code Form

This command selects the sending of short-form or long-form result codes to the DTE. The parameter, if valid, is written to S14 bit 3.

V<value>

<value> Decimal number corresponding to the selected option.

0 Enables short-form (terse) result codes. Line feed is not issued before a short-form result code.

1 Enables long-form (verbose) result codes. (Default.)

OK <value>= 0 or 1.

ERROR Otherwise.

Command: W

Description:

Syntax:

Defined Values:

Result Codes:

Connect Message Control

This command, in conjunction with S95 bits 0, 2, 3, and 5 (bits 2, 3, and 5 can be written directly by the host or by the +MR, +ER, and +DR commands, respectively), control the format of CONNECT messages. The actual result code messages reported reflect the W command setting and the S95 bit settings. (Also see +MR, +ER, and +DR commands.) The W parameter value, if valid, is written to S31 bits 2 and 3.

W<value>

<value> Decimal number corresponding to the selected option.

0 Upon connection, the modem reports only the DTE speed (e.g., CONNECT 19200). Subsequent responses are disabled. (Default.)

1 Upon connection, the modem reports the modulation, line speed, the error correction protocol, and the DTE speed, respectively. Subsequent responses are disabled.

2 Upon connection, the modem reports the DCE speed (e.g., CONNECT 14400).

Subsequent responses are disabled.

OK <value> = 0, 1, or 2.

ERROR Otherwise.

Command: X**Extended Result Codes**

Description:

This command selects the subset of the result code messages used by the modem to inform the DTE of the results of commands. Blind dialing is enabled or disabled by country parameters. If the user wishes to enforce dial tone detection, a "W" can be placed in the dial string (see D command). The information below is based upon the default implementation of the X results table. Table 3-2 indicates the messages which are enabled for each X value.

If the modem is in facsimile mode (+FCLASS=1, 1.0, or 2), the only message sent to indicate a connection is CONNECT without a speed indication.

Syntax:

X<value>

Defined Values:

<value> Decimal number corresponding to the selected option.

0 Disables reporting of busy tones unless forced otherwise by country requirements; send only OK, CONNECT, RING, NO CARRIER, ERROR, and NO ANSWER result codes. Blind dialing is enabled/disabled by country parameters. If busy tone detection is enforced and busy tone is detected, NO CARRIER will be reported. If dial tone detection is enforced or selected and dial tone is not detected, NO CARRIER will be reported instead of NO DIAL TONE. The value 000b is written to S22 bits 6, 5, and 4, respectively.

1 Disables reporting of busy tones unless forced otherwise by country requirements; send only OK, CONNECT, RING, NO CARRIER, ERROR, NO ANSWER, and CONNECT XXXX (XXXX = rate). Blind dialing enabled/disabled by country parameters. If busy tone detection is enforced and busy tone is detected, NO CARRIER will be reported instead of BUSY. If dial tone detection is enforced or selected and dial tone is not detected, NO CARRIER will be reported instead of NO DIAL TONE. The value 100b is written to S22 bits 6, 5, and 4, respectively.

2 Disables reporting of busy tones unless forced otherwise by country requirements; send only OK, CONNECT, RING, NO CARRIER, ERROR, NO DIAL TONE, NO ANSWER, and CONNECT XXXX. If busy tone detection is enforced and busy tone is detected, NO CARRIER will be reported instead of BUSY. If dial tone detection is enforced or selected and dial tone is not detected, NO DIAL TONE will be reported instead of NO CARRIER. The value 101b is written to S22 bits 6, 5, and 4, respectively.

3 Enables reporting of busy tones; send only OK, CONNECT, RING, NO CARRIER, ERROR, NO ANSWER, and CONNECT XXXX. Blind dialing is enabled/disabled by country parameters. If dial tone detection is enforced and dial tone is not detected, NO CARRIER will be reported. The value 110b is written to S22 bits 6, 5, and 4, respectively.

4 Enables reporting of busy tones; send all messages. The value 111b is written to S22 bits 6, 5, and 4, respectively. (Default.)

Result Codes:

OK <value> = 0 to 4.

ERROR Otherwise.

Table 3-2. Result Codes

Short Form	Long Form	n Value in ATXn Command					Notes
		0	1	2	3	4	
+F4	+FCERROR	x	x	x	x	x	
0	OK	x	x	x	x	x	
1	CONNECT	x	x	x	x	x	
2	RING	x	x	x	x	x	
3	NO CARRIER	x	x	x	x	x	
4	ERROR	x	x	x	x	x	
5	CONNECT1200	1	x	x	x	x	
6	NO DIAL TONE	3	3	x	x	x	
7	BUSY	3	3	3	x	x	
8	NO ANSWER	x	x	x	x	x	
9	CONNECT600	1	x	x	x	x	
10	CONNECT 2400	1	x	x	x	x	
11	CONNECT 4800	1	x	x	x	x	
12	CONNECT 9600	1	x	x	x	X	
13	CONNECT 7200	1	x	x	x	x	
14	CONNECT 12000	1	x	x	x	x	
15	CONNECT 14400	1	x	x	x	x	
16	CONNECT 19200	1	x	x	x	x	
17	CONNECT 38400	1	x	x	x	x	
18	CONNECT 57600	1	x	x	x	x	
19	CONNECT 115200	1	x	x	x	x	
20	CONNECT 230400	x	x	x	x	x	
22	CONNECT 75TX/1200RX	1	x	x	x	x	
23	CONNECT 1200TX/75RX	1	x	x	x	x	
24	DELAYED	4	4	4	4	x	
32	BLACKLISTED	4	4	4	4	x	
33	FAX	x	x	x	x	x	
35	DATA	x	x	x	x	x	
40	+MRR: 300	x	x	x	x	x	
44	+MRR: 1200/75	x	x	x	x	x	
45	+MRR: 75/1200	x	x	x	x	x	
46	+MRR: 1200	x	x	x	x	x	
47	+MRR: 2400	x	x	x	x	x	
48	+MRR: 4800	x	x	x	x	x	
49	+MRR: 7200	x	x	x	x	x	
50	+MRR: 9600	x	x	x	x	x	
51	+MRR: 12000	x	x	x	x	x	
52	+MRR: 14400	x	x	x	x	x	
53	+MRR: 16800	x	x	x	x	x	Note 2
54	+MRR: 19200	x	x	x	x	x	Note 2
55	+MRR: 21600	x	x	x	x	x	Note 2
56	+MRR: 24000	x	x	x	x	x	Note 2
57	+MRR: 26400	x	x	x	x	x	Note 2
58	+MRR: 28800	x	x	x	x	x	Note 2
59	CONNECT 16800	1	x	x	x	x	Note 2
60	CONNECT 21600	1	x	x	x	x	Note 2
62	CONNECT 24000	1	x	x	x	x	Note 2

Table 3-2. Result Codes (Continued)

Short Form	Long Form	n Value in ATXn Command					Notes
		0	1	2	3	4	
63	CONNECT 26400	1	x	x	x	x	Note 2
64	CONNECT 28800	1	x	x	x	x	Note 2
66	+DR: A LT	x	x	x	x	x	
67	+DR: V 42B	x	x	x	x	x	
69	+DR: N ONE	x	x	x	x	x	
70	+ER: N ONE	x	x	x	x	x	
77	+ER: L APM	x	x	x	x	x	
78	+MRR: 31200	x	x	x	x	x	Note 2
79	+MRR: 33600	x	x	x	x	x	Note 2
80	+ER: A LT	x	x	x	x	x	
81	+ER: A LT-CELLULAR	x	x	x	x	x	
83	LINE-IN-USE	x	x	x	x	x	
84	CONNECT 33600	1	x	x	x	x	Note 2
91	CONNECT 31200	1	x	x	x	x	Note 2
134	+MCR: B 103	x	x	x	x	x	
135	+MCR: B 212	x	x	x	x	x	
136	+MCR: V 21	x	x	x	x	x	
137	+MCR: V 22	x	x	x	x	x	
138	+MCR: V 22B	x	x	x	x	x	
139	+MCR: V 23	x	x	x	x	x	
140	+MCR: V 32	x	x	x	x	x	
141	+MCR: V 32B	x	x	x	x	x	
142	+MCR: V 34	x	x	x	x	x	Note 3
144	+MCR: K 56	x	x	x	x	x	Note 3
145	+MCR: V 90	x	x	x	x	x	Note 3
150	+MRR: 32000	x	x	x	x	x	Note 3
151	+MRR: 34000	x	x	x	x	x	Note 3
152	+MRR: 36000	x	x	x	x	x	Note 3
153	MRR: 38000	x	x	x	x	x	Note 3
154	+MRR: 40000	x	x	x	x	x	Note 3
155	+MRR: 42000	x	x	x	x	x	Note 3
156	+MRR: 44000	x	x	x	x	x	Note 3
157	+MRR: 46000	x	x	x	x	x	Note 3
158	+MRR: 48000	x	x	x	x	x	Note 3
159	+MRR: 50000	x	x	x	x	x	Note 3
160	+MRR: 52000	x	x	x	x	x	Note 3
161	+MRR: 54000	x	x	x	x	x	Note 3
162	+MRR: 56000	x	x	x	x	x	Note 3
165	CONNECT 32000	x	x	x	x	x	Note 3
166	CONNECT 34000	x	x	x	x	x	Note 3
167	CONNECT 36000	x	x	x	x	x	Note 3
168	CONNECT 38000	x	x	x	x	x	Note 3
169	CONNECT 40000	x	x	x	x	x	Note 3
170	CONNECT 42000	x	x	x	x	x	Note 3
171	CONNECT 44000	x	x	x	x	x	Note 3
172	CONNECT 46000	x	x	x	x	x	Note 3
173	CONNECT 48000	x	x	x	x	x	Note 3
174	CONNECT 50000	x	x	x	x	x	Note 3
175	CONNECT 52000	x	x	x	x	x	Note 3
176	CONNECT 54000	x	x	x	x	x	Note 3
177	CONNECT 56000	x	x	x	x	x	Note 3

Table 3-2. Result Codes (Continued)

Short Form	Long Form	n Value in ATXn Command					Notes
		0	1	2	3	4	
178	CONNECT 230400	x	x	x	x	x	
180	CONNECT 28000	x	x	x	x	x	Note 3
181	CONNECT 29333	x	x	x	x	x	Note 3
182	CONNECT 30667	x	x	x	x	x	Note 3
183	CONNECT 33333	x	x	x	x	x	Note 3
184	CONNECT 34667	x	x	x	x	x	Note 3
185	CONNECT 37333	x	x	x	x	x	Note 3
186	CONNECT 38667	x	x	x	x	x	Note 3
187	CONNECT 41333	x	x	x	x	x	Note 3
188	CONNECT 42667	x	x	x	x	x	Note 3
189	CONNECT 45333	x	x	x	x	x	Note 3
190	CONNECT 46667	x	x	x	x	x	Note 3
191	CONNECT 49333	x	x	x	x	x	Note 3
192	CONNECT 50667	x	x	x	x	x	Note 3
193	CONNECT 53333	x	x	x	x	x	Note 3
194	CONNECT 54667	x	x	x	x	x	Note 3
195	+MRR: 28000	x	x	x	x	x	Note 3
196	+MRR: 29333	x	x	x	x	x	Note 3
197	+MRR: 30667	x	x	x	x	x	Note 3
198	+MRR: 33333	x	x	x	x	x	Note 3
199	+MRR: 34667	x	x	x	x	x	Note 3
200	+MRR: 37333	x	x	x	x	x	Note 3
201	+MRR: 38667	x	x	x	x	x	Note 3
202	+MRR: 41333	x	x	x	x	x	Note 3
203	+MRR: 42667	x	x	x	x	x	Note 3
204	+MRR: 45333	x	x	x	x	x	Note 3
205	+MRR: 46667	x	x	x	x	x	Note 3
206	+MRR: 49333	x	x	x	x	x	Note 3
207	+MRR: 50667	x	x	x	x	x	Note 3
208	+MRR: 53333	x	x	x	x	x	Note 3
209	+MRR: 54667	x	x	x	x	x	Note 3

Notes:

1. An 'x' in a column indicates that the message (either the long form if verbose, or the value only for short form) will be generated when that particular value of 'n' (shown at the top of the column) has been selected by the use of ATXn. If the column is blank, then no message will be generated for that x option. A numeral indicates which less explicit message (verbose or short form) will be output for that X option.
2. SC336 and SC56 modems only.
3. SC56 modems only.

Command: &C

Description:

RLSD (DCD) Option

The modem controls the RLSD output in accordance with the parameter supplied. The parameter value, if valid, is written to S21 bit 5.

Syntax:

&C<value>

Defined Values:

<value> Decimal number corresponding to the selected option.
0 RLSD remains ON at all times.

Result Codes:

1 RLSD follows the state of the carrier. (Default.)
OK 0 or 1.
ERROR Otherwise.

Command: &D DTR Option

Description: This command interprets the ON to OFF transition of the DTR signal from the DTE in accordance with the parameter supplied. The parameter value, if valid, is written to S21 bits 3 and 4. Also, see S25.

Syntax: &D<value>

Defined Values: <value> Decimal number corresponding to the selected option.
 0 DTR drop is interpreted according to the current &Qn setting as follows:
 &Q0, &Q5, &Q6: DTR is ignored (assumed ON). Allows operation with DTEs which do not provide DTR.
 &Q1: DTR drop causes the modem to hang up. Auto-answer is not affected.
 &Q2, &Q3: DTR drop causes the modem to hang up. Auto-answer is inhibited. 1 DTR drop is interpreted according to the current &Qn setting as follows:
 &Q0, &Q1, &Q5, &Q6: DTR drop is interpreted by the modem as if the asynchronous escape sequence had been entered. The modem returns to asynchronous command state without disconnecting.
 &Q2, &Q3: DTR drop causes the modem to hang up. Auto-answer is inhibited. 2 DTR drop is interpreted according to the current &Qn setting as follows:
 &Q0 through &Q6: DTR drop causes the modem to hang up. Auto-answer is inhibited. (Default.)
 3 DTR drop is interpreted according to the current &Qn setting as follows:
 &Q0, &Q1, &Q5, &Q6: DTR drop causes the modem to perform a soft reset as if the Z command were received. The &Y setting determines which profile is loaded. &Q2, &Q3: DTR drop causes the modem to hang up. Auto-answer is inhibited. If &Q5, &Q6, +FCLASS=1 or +FCLASS=2 is in effect, the action taken is the same as for &Q0.

Command: &K Flow Control

Description: This command defines the DTE/DCE (terminal/modem) flow control mechanism. The parameter value, if valid, is written to S39 bits 0, 1, and 2.

Syntax: &K<value>

Defined Values: <value> Decimal number corresponding to the selected option.
 0 Disables flow control.
 3 Enables RTS/CTS flow control. (Default for data modem modes.)
 4 Enables XON/XOFF flow control.
 5 Enables transparent XON/XOFF flow control.
 Note: Upon reset, both RTS/CTS and XON/XOFF flow control is enabled for fax modem and voice modes.

Result Codes: OK <value> = 0, 3, 4, or 5.
 ERROR Otherwise.

Command: &R RTS/CTS Option

Description: This selects how the modem controls CTS. CTS operation is modified if hardware flow control is selected (see &K command). The parameter value, if valid, is written to S21 bit 2.

Syntax: &R<value>

Defined Values: <value> Decimal number corresponding to the selected option.
 0 In sync mode, CTS tracks the state of RTS; the RTS-to-CTS delay is defined by S26. In async mode, CTS is normally ON and will turn OFF only if required by flow control.
 1 In sync mode, CTS is always ON (RTS transitions are ignored). tracks the state of RTS; In async mode, CTS is normally ON and will turn OFF only if required by flow control.

Result Codes: OK <value> = 0 or 1.
 ERROR Otherwise.

Command: &S**DSR Override**

Description: This command selects how the modem will control DSR. The parameter value, if valid, is written to S21 bit 6.

Syntax: &S<value>

Defined Values: <value> Decimal number corresponding to the selected option.
&0 DSR will remain ON at all times. (Default.)
&1 DSR will become active after answer tone has been detected and inactive after the carrier has been lost.

Result Codes: OK <value> = 0 or 1.
ERROR Otherwise.

Command: +IPR**Fixed DTE Rate**

Description: This numeric extended-format parameter specifies the data rate at which the modem will accept commands during online operation. It may be used to select operation at rates at which the modem is not capable of automatically detecting the data rate being used by the DTE. Specifying a value of 0 disables the function and allows operation only at rates automatically detectable by the modem. The specified rate takes effect following the issuance of any result code(s) associated with the current command line. The <rate> specified does not apply in OnLine Data State if Normal Mode (Direct Mode) of operation is selected.

Syntax: +IPR=<rate>

Defined Values: <rate> Specifies the DTE-modem interface operation rate in bits/s. The available rates are: 0, 300, 1200, 2400, 4800, 9600, 19200, 38400, 57600, 115200, or 230400.

If unspecified or set to 0, automatic detection is selected and the character format is also forced to autodetect, +ICF=0.

If the rate specified is not supported by the modem, an ERROR result code will be returned.

Reporting Current or Selected Values:

Command: +IPR?
Response: +IPR: <rate>
Example 1: +IPR: 0 For automatic rate detection.
Example 2: +IPR: 115200 For 115200 bps.

Reporting Supported Range of Parameter Values:

Command: +IPR=?
Response: +IPR (<rate> range)
Example: +IPR: (0,300,1200,2400,4800,9600,19200,38400,57600,115200, 230400)

Command: +IFC DTE-Modem Local Flow Control

Description: This extended-format compound parameter controls the operation of local flow control between the DTE and the modem during the data state when V.42 error control is used, or when fallback to non-error control mode is specified to include buffering and flow control. It accepts two numeric subparameters.

Syntax: +IFC=[<modem_by_DTE>[,<DTE_by_modem>]]

Defined Values: <modem_by_DTE> Specifies the method to be used by the DTE to control the flow of received data from the modem.
 0 None.
 1 XON/XOFF on transmitted data (XON/XOFF on transmit data); do not pass XON/XOFF characters to the remote modem.
 2 Circuit 133 (Ready for Receiving). (Default.)
 3 DC1/DC3 on circuit 103 (Transmitted Data) with DC1/DC3 characters being passed through to the remote DCE in addition to being acted upon for local flow control

<DTE_by_modem> Specifies the method to be used by the modem to control the flow of transmitted data from the DTE.
 0 None.
 1 XON/XOFF on received data.
 2 CTS/RTS. (Default.)

Reporting Current or Selected Values:
 Command: +IFC?
 Response: +IFC: <modem_by_DTE>,<DTE_by_modem>
 Example: +IFC: 2,2 For the defaults.

Reporting Supported Range of Parameter Values:
 Command: +IFC=?
 Response: +IFC: (<modem_by_DTE> range),(<DTE_by_modem> range)
 Example: +IFC: (0-3),(0-2).

Command: +ILRR DTE-Modem Local Rate Reporting

Description: This extended-format numeric parameter controls whether or not the extended-format +ILRR:<rate> information text is transmitted from the modem to the DTE.

Syntax: +ILRR=<value>

Defined Values: <value> Decimal number corresponding to the selected option.
 0 Disables reporting of local port rate (+ILRR: is not transmitted). (Default.)
 1 Enables reporting of local port rate (+ILRR: is transmitted).

Reporting Current or Selected Values:
 Command: +ILRR?
 Response: +ILRR: <current value>
 Example: +ILRR: 0 For the default setting

Reporting Supported Range of Parameter Values:
 Command: +ILRR=?
 Response: +ILRR: (<value> range)
 Example: +ILRR: (0,1)

Reported Rate:

The <rate> reported represents the current (negotiated or renegotiated) DTE-modem rate. If enabled, the intermediate result code is transmitted after any modulation, error control or data compression reports are transmitted, and before any final result code (e.g., CONNECT) is transmitted. The <rate> is applied after the final result code is transmitted.

The DTE-modem port rate will change only if neither buffered mode nor error controlled means are enabled (+ES=x,0) and if the negotiated carrier rate (+MRR) does not match the current DTE-modem port rate (autodetected from the previous command line).

Syntax: +ILRR: <rate>[,<rx_rate>].

Defined Values: <rate> Decimal value representing the current (negotiated or renegotiated) DTE-modem rate: 0, 300, 1200, 2400, 4800, 9600, 19200, 38400, 57600, 115200, or 230400
 <rx_rate> Optional decimal value reporting the RXD rate, if it is different from the TXD rate: 0, 300, 1200, 2400, 4800, 9600, 19200, 38400, 57600, 115200, or 230400

Example: +ILRR: 19200

Call Control Commands

Command:	D	Dial
Description:		<p>This command directs the modem to go on-line, dial according to the string entered and attempt to establish a connection. If no dial string is supplied, the modem will go on-line and attempt the handshake in originate mode.</p> <p>NOTE: If the ATD command is issued before the S1 register has cleared, the modem will respond with the NO CARRIER result code.</p> <p>If +FCLASS=0 is selected, the modem will behave as a data modem and will attempt to connect to another data modem. The modem will have up to the period of time specified by register S6 or S7 to wait for carrier and complete the handshake. If this time expires before the modem can complete the handshake, the modem will go on-hook with the NO CARRIER response. This command will be aborted in progress upon receipt of any DTE character before completion of the handshake.</p> <p>If +FCLASS=1, 1.0, or 2 is selected, the modem will behave as a facsimile modem and attempt to connect to a facsimile machine (or modem) by entering the HDLC V.21 channel 2 receive state (as if +FRH=3 had been issued). This command will be aborted upon receipt of any DTE character if the modem has not finished dialing. In this case, the modem will go on-hook and return to command mode after displaying the NO CARRIER message. If the modem has finished dialing, it proceeds as if the +FRH=3 command has been issued. (Refer to the +FRH command to determine how the modem behaves following this stage.)</p>
Dial Modifiers:		The valid dial string parameters are described below. Punctuation characters may be used for clarity, with parentheses, hyphen, and spaces being ignored.
Syntax:		D<string>
Defined Values:		<string> Character string corresponding to the selected option(s).
	0-9	DTMF digits 0 to 9.
	*	The 'star' digit (tone dialing only).
	#	The 'gate' digit (tone dialing only).
	A-D	DTMF digits A, B, C, and D. Some countries may prohibit sending of these digits during dialing.
	L	Re-dial last number: the modem will re-dial the last valid telephone number. The L must be immediately after the D with all the following characters ignored).
	P	Select pulse dialing: pulse dial the numbers that follow until a "T" is encountered. Affects current and subsequent dialing. Some countries prevent changing dialing modes after the first digit is dialed.
	T	Select tone dialing: tone dial the numbers that follow until a "P" is encountered. Affects current and subsequent dialing. Some countries prevent changing dialing modes after the first digit is dialed.
	R	This command will be accepted, but not acted on.
	S=n	Dial the number stored in the directory (n = 0 to 3). (See &Z.)
	!	Flash: the modem will go on-hook for a time defined by the value of S29. Country requirements may limit the time imposed.
	W	Wait for dial tone: the modem will wait for dial tone before dialing the digits following "W". If dial tone is not detected within the time specified by S7 (US) or S6 (W-class), the modem will abort the rest of the sequence, return on-hook, and generate an error message.
	@	Wait for silence: the modem will wait for at least 5 seconds of silence in the call progress frequency band before continuing with the next dial string parameter. If the modem does not detect these 5 seconds of silence before the expiration of the call abort timer (S7), the modem will terminate the call attempt with a NO ANSWER message. If busy detection is enabled, the modem may terminate the call with the BUSY result code. If answer tone arrives during execution of this parameter, the modem handshakes.
	&	Wait for credit card dialing tone before continuing with the dial string. If the tone is not detected within the time specified by S7 (US models) or S6 (W-class models), the modem will abort the rest of the sequence, return on-hook, and generate an error message.
	,	Dial pause: the modem will pause for a time specified by S8 before dialing the digits following ",".
	;	Return to command state. Added to the end of a dial string, this causes the modem to return to the command state after it processes the portion of the dial string preceding the ";". This allows the user to issue additional AT commands while remaining off-hook. The additional AT commands may be placed in the original command line following the ";" and/or may be entered on subsequent command lines. The modem will enter call

	progress only after an additional dial command is issued without the ";" terminator. Use "H" to abort the dial in progress, and go back on-hook.
^	Toggles calling tone enable/disable: applicable to current dial attempt only.
()	Ignored: may be used to format the dial string.
-	Ignored: may be used to format the dial string.
<space>	Ignored: may be used to format the dial string.
<i>	Invalid character: will be ignored.
>	If enabled by country specific parameter, the modem will generate a grounding pulse on the EARTH relay output.

Command: T**Set Tone Dial Default**

Description:

This command forces DTMF dialing until the next P dial modifier or P command is received. The modem will set an S-Parameter bit to indicate that all subsequent dialing should be conducted in tone mode. The DP command will override this command. Clears S14 bit 5.

Result Code:

This command may not be permitted in some countries. (See P.)
OK

Command: P**Set Pulse Dial Default**

Description:

This command forces pulse dialing until the next T dial modifier or T command is received. Sets S14 bit 5.
As soon as a dial command is executed which explicitly specifies the dialing mode for that particular call (e.g., ATDT...), this command is overridden so that all future dialing will be tone dialed. (See T command.)

Result Code:

This command may not be permitted in some countries.
OK

Command: A**Answer**

Description:

The modem will go off-hook and attempt to answer an incoming call if correct conditions are met. Upon successful completion of answer handshake, the modem will go on-line in answer mode. This command may be affected by the state of Line Current Sense, if enabled. (Most countries do not require Line Current Sense.) Operation is also dependent upon +FCLASS command and country-specific requirements.
If +FCLASS=0 is selected, the modem will enter the connect state after exchanging carrier with the remote modem. If no carrier is detected within a period specified in register S7, the modem hangs up. Any character entered during the connect sequence will abort the connection attempt.
If +FCLASS=1, 1.0, or 2 is selected, the modem will go off-hook in V.21 answer mode. It will generate the V.21 2100 Hz answer tone for 3 ± 0.5 seconds and, following a delay of 70 ms, will proceed as if the +FTH=3 command were issued. At any stage up to (but excluding) the +FTH=3 command state, any character will abort the communication. (See the description of the +FTH command for details.)

Command:	H	Disconnect (Hang-Up)
Description:		This command initiates a hang up sequence. This command may not be available for some countries due to PTT restrictions.
Syntax:		H<value>
Defined Values:		<value> Decimal number corresponding to the selected option. 0 The modem will release the line if the modem is currently on-line, and will terminate any test (AT&T) that is in progress. Country specific, modulation specific, and error correction protocol specific (S38) processing is handled outside of the H0 command. 1 If on-hook, the modem will go off-hook and enter command mode. For US models, the modem will remain off-hook. For W-class models, the modem will return on-hook after a period of time determined by S7.
Result Codes:		OK <value> = 0 or 1. ERROR Otherwise.
Command:	O	Return to On-Line Data Mode
Description:		This command determines how the modem will enter the on-line data mode. If in the on-line command mode, the modem enters the on-line data mode with or without a retrain. If in the off-line command mode (no connection), the modem reports ERROR.
Syntax:		O<value>
Defined Values:		<value> Decimal number corresponding to the selected option. 0 Enters on-line data mode without a retrain. Handling is determined by the Call Establishment task. Generally, if a connection exists, this command connects the DTE back to the remote modem after an escape (+++). 1 Enters on-line data mode with a retrain before returning to on-line data mode. 2 Fast retrain without speed change (used for diagnostic purpose only). 3 Renegotiate rate without speed change (used for diagnostic purpose only). 4 Renegotiate rate down one speed (used for diagnostic purpose only). 5 Renegotiate rate up one speed (used for diagnostic purpose only).
Result Codes:		OK <value> = 0 to 5 and a connection exists. ERROR Otherwise or if not connected.
Command:	L	Speaker Volume
Description:		This command sets the speaker volume control. The parameter value, if valid, is written to S22 bits 0 and 1.
Syntax:		L<value>
Defined Values:		<value> Decimal number corresponding to the selected option. 0 Low volume. 1 Low volume. (Default.) 2 Medium volume. 3 High volume.
Result Codes:		OK <value> = 0 to 3. ERROR Otherwise.
Command:	M	Speaker Control
Description:		This command selects when the speaker will be on or off. The parameter value, if valid, is written to S22 bits 2 and 3.
Syntax:		M<value>
Defined Values:		<value> Decimal number corresponding to the selected option. 0 Speaker is always off. 1 Speaker is on during call establishment, but off when receiving carrier. (Default.) 2 Speaker is always on. 3 Speaker is off when receiving carrier and during dialing, but on during answering.
Result Codes:		OK <value> = 0 to 3. ERROR Otherwise.

Command:	&G	Select Guard Tone
Description:		This command causes the modem to generate the guard tone selected by this command (DPSK modulation modes only). The parameter value, if valid, is written to S23 bits 6 and 7.
Syntax:		&G<value>
Defined Values:		<value> Decimal number corresponding to the selected option. 0 Disables guard tone. (Default.) 1 Disables guard tone. 2 Selects 1800 Hz guard tone.
Result Codes:		This command may not be permitted in some countries. <value> = 0 to 2. ERROR Otherwise.
Command:	&P	Select Pulse Dial Make/Break Ratio
Description:		This command determines the make/break ratio used during pulse dialing. The default is country-dependent. The parameter value, if valid, is written to S28 bits 3 and 4.
Syntax:		&P<value>
Defined Values:		<value> Decimal number corresponding to the selected option. 0 Selects 39%-61% make/break ratio at 10 pulses per second. (Default.) 1 Selects 33%-67% make/break ratio at 10 pulses per second. 2 Selects 39%-61% make/break ratio at 20 pulses per second. 3 Selects 33%-67% make/break ratio at 20 pulses per second.
Result Codes:		OK <value> = 0 to 3. ERROR Otherwise.
Command:	&V	Display Current Configuration and Stored Profiles
Description:		This command reports the current (active) configuration, the stored (user) profiles, and the first four stored telephone numbers. The stored profiles and telephone numbers are not displayed if the NVRAM is not installed or is not operational as detected by the NVRAM test during reset processing.
Result Code:		OK
Example:		AT&V ACTIVE PROFILE: B1 E1 L1 M1 N0 QO T V1 W0 X4 Y0 &C1 &D2 &G0 &J0 &K3 &Q5 &R1 &S0 &T5 &X0 S00:000 S01:000 S02:043 S03:013 S04:010 S05:008 S06:002 S07:050 S08:002 S09:006 S10:014 S11:095 S12:050 S18:000 S25:005 S26:001 S36:007 S38:020 S46:138 S48:007 S95:000 STORED PROFILE 0: B1 E1 L1 M1 N0 QO T V1 W0 X4 Y0 &C1 &D2 &G0 &J0 &K3 &Q5 &R1 &S0 &T5 &X0 S00:000 S02:043 S06:002 S07:050 S08:002 S09:006 S10:014 S11:095 S12:050 S18:000 S36:007 S40:104 S41:195 S46:138 S95:000 STORED PROFILE 1: B1 E1 L1 M1 N0 QO T V1 W0 X4 Y0 &C1 &D2 &G0 &J0 &K3 &Q5 &R1 &S0 &T5 &X0 S00:000 S02:043 S06:002 S07:050 S08:002 S09:006 S10:014 S11:095 S12:050 S18:000 S36:007 S40:168 S41:195 S46:138 S95:000 TELEPHONE NUMBERS: 0 = 1 = 2 = 3 = OK.

Command: &V1

Description:

Display Last Connection Statistics

Displays the last connection statistics in the following format (shown with typical results):

```

TERMINATION REASON..... LOCAL REQUEST
LAST TX rate..... 26400 BPS
HIGHEST TX rate..... 26400 BPS
LAST RX rate..... 49333 BPS
HIGHEST RX rate..... 49333 BPS
PROTOCOL..... LAPM
COMPRESSION..... V42Bis
Line QUALITY..... 038
Rx LEVEL..... 015
Highest Rx State..... 67
Highest TX State..... 67
EQM Sum..... 00B4
Min Distance..... 0000
RBS Pattern..... 00
Rate Drop..... 00
Digital Loss..... 2000
Local Rtrn Count..... 00
Remote Rtrn Count..... 00
Flex 9481814347C4

```

RBS Pattern: Shows which bits are being robbed in the least significant 6 bytes, e.g., 03 indicates 2 robbed bits in bit positions 0 and 1.

Digital Loss: Shows if a pad was encountered and if so, what was the digital loss. 2000 means 0dB.

Flex: Shows V.8bis information as follows:

First byte: Octet 13 (second byte of manufacturer id, 94 = K56flex)

Second byte: Octet 14 (Licensee code: 81 = Conexant)

Third byte: Octet 15 (manufacturer's product capabilities)

Fourth byte: Octet 16 (K56flex version number)

Fifth byte: Octet 17 (Conexant pump code version number)

Sixth byte: Octet 18 (x-law and controller version number)

Bit 6 Forced/Not forced A-Law/ μ -Law

0 = Forced A-Law/ μ -Law.

1 = Not forced A-Law/ μ -Law.

Bit 5 Select A-Law or μ -Law

0 = Select A-Law.

1 = Select μ -Law.

Bit 4:0 Controller version

Command: \W

Description:

Syntax:

Defined Values:

Single Line Connect Message Enable

This command enables or disables the single line connect message format as follows:

\W<value>

<value> Decimal number corresponding to the selected option.

0 Connect messages are controlled by the command settings X, W, and S95.

1 Connect messages are displayed in the single line format described below subject to the command settings V (Verbose) and Q (Quiet). In Non-Verbose mode (V0), single line connect messages are disabled and a single numeric result code is generated for CONNECT DTE.

When single line connect messages are enabled, there are no CARRIER, PROTOCOL (+ER:), or COMPRESSION (+DR:) messages apart from the fields described below.

The single line connect message format is:

```

CONNECT <DTE Speed>/<Modulation>/<Protocol>/<Compression>/
<Line Speed>

```

Where:

DTE Speed = DTE speed, e.g., 57600.

Modulation = "V92" for V.92 modulation.

"V90" for V.90 modulation.

"K56" for K56flex modulation.

"V34" for V.34 modulation.

"V32" for V.32 or V.32bis modulation.

Note: Modulation is omitted for all other modulations.

Protocol = "NONE" for no protocol.
 "ALT" for Microcom Network Protocol.
 "LAPM" for LAP-M protocol.

Compression = "V44" for V.44 compression.
 "V42B" for V.42bis compression.
 "ALT" for Microcom MNP5 compression.

Note: Compression is omitted if protocol is NONE.

Line Speed = Asymmetric rates are displayed as "/rate:TX/rate:RX", e.g., /1200 TX/75 RX.
 Symmetric rates are displayed as a single DCE rate, e.g., 14400.

Command: %L**Report Line Signal Level**

Description:

Returns a value which indicates the received signal level. The value returned is a direct indication (DAA dependent) of the receive level at the MDP, not at the telephone line connector. For example, 009 = -9 dBm, 043 = -43 dBm, and so on.

Result Codes:

OK

Command: %Q**Report Line Signal Quality**

Description:

Reports the line signal quality (DAA dependent). Returns the higher order byte of the EQM value. Based on the EQM value, retrain or fallback/fall forward may be initiated if enabled by %E1 or %E2.

Example:

AT%Q

015

Result Codes:

OK If connected.

ERROR If not connected, or connected in 300 bps, V.23, or fax modes.

Command: –STE= Set Telephony Extension

Description: The –STE command enables/disables Line-In-Use, Extension Pickup, and Remote Hangup detection features.

Note: Additional hardware may be required to support these features.

Syntax: –STE=<value>

Defined Values: <value> Decimal number corresponding to the selected bit-mapped options. The bit fields are defined as follows:

- Bit 0 Line-In-Use detection enable/disable.
- Bit 1 Extension Pickup detection enable/disable.
- Bit 2 Remote Hangup detection enable/disable.

<value> (Dec.)	Remote Hangup	Extension Pickup	Line-in-Use
0 (default)	Disabled	Disabled	Disabled
1	Disabled	Disabled	Enabled
2	Disabled	Enabled	Disabled
3	Disabled	Enabled	Enabled
4	Enabled	Disabled	Disabled
5	Enabled	Disabled	Enabled
6	Enabled	Enabled	Disabled
7	Enabled	Enabled	Enabled

Reporting Current or Selected Values:

Command: –STE?

Response: –STE: <value>

Example: –STE: 4 Remote Hangup enabled, Extension Pickup disabled, and Line-In-Use disabled.

Reporting Supported Range of Parameter Values:

Command: –STE=? Show available options.

Response: –STE: 0-7

Result Codes:

OK <value> = 0-7

ERROR Otherwise.

Behavior in Data Mode (+FCLASS=0):

When on-hook, if the line is in use and an ATDT is issued, the modem will not go off-hook and will return with the message LINE-IN-USE.

When off-hook and either an extension is picked up or a line reversal is detected, the modem will drop the connection. The disconnect reason in register S86=25 (this is also defined for #UD). The user must flash the hook in order to get a dial tone due because the remote server will be retraining.

If the local handset is picked up while the modem is off-hook, the modem will do a link-disconnect, flash the hook for 1.5 seconds, then connect the local handset to the line. At this point, the user dial tone should be on the local handset. The disconnect reason in S86=25.

Behavior in Voice Mode (+FCLASS=8):

When in voice mode and an extension is picked-up, a <DLE>P is sent to the DTE.

When the modem is off-hook, a line reversal may also be detected in which case a <DLE>I is sent to the DTE.

In voice mode, there is no blocking of ATDT when the line is in use. Also, there is no automatic hang-up in voice mode as in data mode. There is only the above stated <DLE> shielding event reporting.

Operation in Data Mode:

Line-In-Use (Enabled by AT-STE=1, AT-STE=3, AT-STE=5, or AT-STE=7)

Case 1: Telephone Line is in Use

If an ATDT, ATDP or ATDL is issued while Line-In-Use detection is enabled and the telephone line is in use, the modem will immediately return the message LINE-IN-USE to the DTE without going off-hook, and then return to command mode.

Case 2: Telephone Line is in Use But Disconnected

If an ATDT, ATDP or ATDL is issued while Line-In-Use detection is enabled and the telephone line is NOT in use, the modem will go off-hook after a short pause, then respond with CONNECT or NO CARRIER message.

Case 3: Telephone Line is Not Connected to Modem

If an ATDT, ATDP or ATDL is issued while Line-In-Use detection is enabled and the telephone line is not connected, the modem will go off-hook momentarily, go back on-hook, then respond with NO DIAL TONE message.

Extension Pick-up (Enabled by AT-STE=2, AT-STE=3, AT-STE=6, or AT-STE=7):Case 1: Modem off-hook, Local Handset Goes Off-Hook

If the local handset goes off-hook while the modem is in a data connection, the local handset will be muted. The modem will then send a GSTN Cleardown to the remote modem and then go on-hook. The modem will then send a NO CARRIER message to the DTE. A result code of 25 will be left in S86 register. After 2 seconds, the local handset will be connected to the telephone line so the user hears the dial tone.

Remote Hang-up (enabled by AT-STE=4, AT-STE=5, AT-STE=6, or AT-STE=7):Case 1: Modem off-hook, Remote Hang-up

If the modem is connected (off-hook) and the remote modem/server goes hangs up, the central office may issue a line polarity reversal. If a line polarity reversal is detected, the modem will drop the call and respond with NO CARRIER. The reason for hang-up can be determined by #UD or by S86=25. A line reversal can also be simulated by simply pulling out the telephone line during a connection.

Operation in Voice Mode

Line-In-Use (enabled by AT-STE=1, AT-STE=3, AT-STE=5, or AT-STE=7):

This feature does not apply in voice mode.

Extension Pickup (Enabled by AT-STE=2, AT-STE=3, AT-STE=6, or AT-STE=7)

If the modem is off-hook and an extension goes off-hook, the modem issues a <DLE>P to the DTE. The application software should then hang up the line (VLS=0).

Remote Hang-up (Enabled by AT-STE=4, AT-STE=5, AT-STE=6, or AT-STE=7)

If the modem is off-hook and the remote user goes on-hook, the modem issues a <DLE>P to the DTE. The application software should then hang up the line (VLS=0).

Examples:

User is talking on an extension and the modem tries to dial

```
AT-STE=7
ATDT555-1212
LINE-IN-USE.
```

The line is not in use and the modem tries to dial

```
AT-STE=7
ATDT555-1212
Modem goes off-hook
CONNECT
```

An extension is off-hook but there is silence on the line and the modem tries to dial

```
AT-STE=3
ATDT555-1212
Modem goes off-hook
NO DIAL TONE
```

Modem is connected in data mode and remote modem goes on-hook

```
AT-STE=4
ATDT555-1212
CONNECT
NO CARRIER Remote modem drops line
ATS86=?
025
```

Modem is in answer machine mode and an extension goes off-hook

```
AT-STE=2
AT+FCLASS=8
OK
<DLE>h Local handset on-hook
<DLE>R Ring
AT+VLS=1
OK
AT+VSM=1,7200,0,0
AT+VTX Starts to play greeting message
<DLE>P User picks up extension
<DLE>! DTE send abort to end playback
AT+VLS=0 DTE hangs up.
```

Automated system that needs to periodically use the line while giving the voice user the highest priority

A common use for these features would be an automated system that needs to periodically use the line while giving the voice user the highest priority. The automated system would make a connection when the line is free. It would do this without disturbing the line if the line is in use. The automated system would periodically retry the connection until the line is free. Once the line is free it would dial and make its connection. If a voice user wishes to use the line while the modem is connected. The modem will drop the line and give the line to the user. The modem will then try to regain control of the line by once again periodically retrying to establish a connection.

```
AT-STE=7
OK
ATDT5551212
CONNECT
Sometime later, the user picks up phone
NO CARRIER
ATS86?
25
OK
Delay 30 seconds
ATDT5551212
LINE-IN-USE
Try again some time later user hangs up the phone
CONNECT
```

Modulation Control Commands

Command: +MS

Modulation Selection

Description: This extended-format compound parameter controls the manner of operation of the modulation capabilities in the modem. It accepts six subparameters.

Syntax: +MS=[<carrier>[,<automode>[,<min_tx_rate>[,<max_tx_rate>[,<min_rx_rate>[,<max_rx_rate>]]]]]]
 Where possible <carrier>, <min_tx_rate>, <max_tx_rate>, <min_rx_rate>, and <max_rx_rate> values are listed in Table 3-3.

Table 3-3. +MS Command Supported Rates

Modulation	carrier>	Possible (<min_rx_rate>, <min_tx_rate>, <min_tx_rate>), and <max_tx_rate> Rates (bps)
Bell 103	B103	300
Bell 212	B212	1200 Rx/75 Tx or 75 Rx/1200 Tx
V.21	V21	300
V.22	V22	1200
V.22 bis	V22B	2400 or 1200
V.23	V23C	1200
V.32	V32	9600 or 4800
V.32 bis	V32B	14400, 12000, 9600, 7200, or 4800
V.34	V34	33600, 31200, 28800, 26400, 24000, 21600, 19200, 16800, 14400, 12000, 9600, 7200, 4800, or 2400
K56flex	K56	56000, 54000, 52000, 50000, 48000, 46000, 44000, 42000, 40000, 38000, 36000, 34000, 32000
V.90	V90	56000, 54667, 53333, 52000, 50667, 49333, 48000, 46667, 45333, 44000, 42667, 41333, 40000, 38667, 37333, 36000, 34667, 33333, 32000, 30667, 29333, 28000
V.92 downstream		V92 56000, 54667, 53333, 52000, 50667, 49333, 48000, 46667, 45333, 44000, 42667, 41333, 40000, 38667, 37333, 36000, 34667, 33333, 32000, 30667, 29333, 28000
V.92 upstream	V92	48000, 46667, 45333, 44000, 42667, 41333, 40000, 38667, 37333, 36000, 34667, 33333, 32000, 30667, 29333, 28000, 26667, 25333, 24000

Note: Some <carrier> values may not be supported by certain model models. For example, modem models supporting V92 may not support K56.

Defined Values:

<carrier> A string which specifies the preferred modem carrier to use in originating or answering a connection. <carrier> values are strings of up to eight characters, consisting only of numeric digits and upper case letters. <carrier> values for ITU standard modulations take the form: <letter><1-4 digits><other letters as needed>. Defined values are listed in Table 3-3.

<automode> A numeric value which enables or disables automatic modulation negotiation (e.g., ITU-T V.32bis Annex A or V.8).
 0 = Automode disabled.
 1 = Automode enabled. (Default.)

<min_rx_rate> and <max_rx_rate>
 Numeric values which specify the lowest (<min_rx_rate>) and highest (<max_rx_rate>) rate at which the modem may establish a receive connection. May be used to condition distinct limits for the receive direction as distinct from the transmit direction. Values for this subparameter are decimal encoded, in units of bit/s. The possible values for each modulation are listed in Table 3-3. Actual values will be limited to possible values corresponding to the entered <carrier> and fall-back <carrier> as determined during operation. (Default = lowest (<min_rx_rate>) and highest (<max_rx_rate>) rate supported by the selected carrier.)

<min_tx_rate> and <max_tx_rate>
 Numeric values which specify the lowest (<min_tx_rate>) and highest (<max_tx_rate>) rate at which the modem may establish a transmit connection. Non-zero values for this

subparameter are decimal encoded, in units of bit/s. The possible values for each modulation are listed in Table 3-3.

Actual values will be limited to possible values corresponding to the entered <carrier> and fall-back <carrier> as determined during operation. (Default = lowest (<min_tx_rate>) and highest (<max_tx_rate>) rate supported by the selected carrier.)

Reporting Current or Selected Values:

Command: +MS?

Response: +MS:<carrier>,<automode>,<min_tx_rate>, <max_tx_rate>,<min_rx_rate>,<max_rx_rate>

Note: The current active settings are reported under control of the +MR parameter.

Example: +MS: K56, 1,300,33600,300,56000

For default values. This example allows maximum system flexibility to determine optimal receive and transmit rates during operation.

Reporting Supported Range of Parameter Values:

Command: +MS=?

Response: +MS: (< carrier> range),(<automode> range),(<min_tx_rate> range), (<max_tx_rate> range), (<min_rx_rate> range), (<max_rx_rate> range)

Example 1: +MS:(B103,B212,V21,V22,V22B,V23C,V32,V32B,V34,K56,V90),(0,1),(300-33600),(300-33600),(300-56000),(300-56000)

Example 2: +MS:(B103,B212,V21,V22,V22B,V23C,V32,V32B,V34,V90,V92),(0,1),(300-33600),(300-33600),(300-56000),(300-56000)

Result Code:

OK Valid subparameter string

ERROR Otherwise.

Command: +MR

Modulation Reporting Control

Description:

This extended-format numeric parameter controls whether or not the extended-format +MCR:<carrier> and +MRR:<rate> intermediate result codes are transmitted from the modem to the DTE. If enabled, +MCR:<carrier> and +MRR:<rate> intermediate result codes represent the current (negotiated or renegotiated) modulation <carrier> and <rate> that are transmitted at the point during connect negotiation (handshaking) at which the modem has determined which modulation and rate will be used, i.e., before any Error Control or Data Compression reports are transmitted, and before any final result code (e.g., CONNECT) is transmitted.

S95 bit 2 is reset to 0 for +MR=0 and is set to a 1 for +MR=1 or +MR=2. The more recent setting of +MR or S95 bit 2, and the W command setting, determines modulation result code reporting (see S95 Parameter and W Command).

Syntax:

+MR=[<value>]

Defined Values:

<value> A decimal number corresponding to the selected option:

0 Disables reporting of modulation connection (+MCR: and +MRR: are not transmitted). (Default.)

1 Enables reporting of modulation connection (+MCR: and +MRR: are transmitted with tx rate, rx rate).

2 Enables reporting of modulation connection (+MCR: and +MRR: are transmitted with rx rate only).

Reporting Current or Selected Values:

Command: +MR?

Response: +MR: <current value>

Example: +MR: 0 For default setting

Reporting Supported Range of Parameter Values:

Command: +MR=?

Response: +MR: (<value>range)

Example: +MR: (0-2)

+MCR: Report Syntax:

Response: +MCR: <carrier>

<carrier> Alphanumeric code corresponding to the reported carrier.

Defined values are:

B103 For Bell 103

B212 For Bell 212

V21 For V.21

V22 For V.22

V22B For V.22bis

V23C For V.23

V32 For V.32

V32B For V.32bis

	V34 For V.34 K56 For K56flex V90 For V.90 V92 For V.92
+MRR: Report Syntax:	Response: +MRR: <tx_rate>,<rx_rate> <tx_rate> Decimal transmit rate in bits/s. <rx_rate> Decimal receive rate in bits/s. Example: +MRR: 28800, 48000
Command:	%E Enable/Disable Line Quality Monitor and Auto-Retrain or Fallback/Fall Forward
Description:	Controls whether or not the modem will automatically monitor the line quality and request a retrain (%E1) or fall back when line quality is insufficient or fall forward when line quality is sufficient (%E2). The parameter value, if valid, is written to S41 bits 2 and 6. If enabled, the modem attempts to retrain for a maximum of 30 seconds. Fallback/Fall Forward. When %E2 is active, the modem monitors the line quality (EQM). When line quality is insufficient, the modem will initiate a rate renegotiation to a lower speed within the V.34/V.32 bis/V.32 (RC336) modulation speeds. The modem will keep falling back within the current modulation if necessary until the speed reaches 2400 bps (V.34) or 4800 bps (V.32). Below this rate, the modem will only do retrains if EQM thresholds are exceeded. If the EQM is sufficient for at least one minute, the modem will initiate a rate renegotiation to a higher speed within the current modulation speeds. The rate renegotiations will be done without a retrain if a V.32 bis connection is established. Speeds attempted during fallback/fall forward are those shown to be available in the rate sequences exchanged during the initial connection. Fallback/fall forward is available in error correction and normal modes, but not in direct mode or synchronous mode with external clocks.
Syntax:	%E<value>
Defined Values:	<value> Decimal number corresponding to the selected option. 0 Disable line quality monitor and auto-retrain. 1 Enable line quality monitor and auto-retrain. 2 Enable line quality monitor and fallback/fall forward. (Default.)
Result Codes:	OK <value> = 0, 1, or 2. ERROR Otherwise.
Command:	%U Select μ-Law or A-Law Codec Type
Description:	This command selects μ -Law or A-Law codec type for V.90 and K56flex modulation. This command also stores the selected setting directly to NVRAM. The default value is country specific.
Syntax:	%U<value>
Defined Values:	<value> Decimal number corresponding to the selected option. 0 Selects μ -Law. 1 Selects A-Law.
Result Codes:	OK <value> = 0 or 1 ERROR Otherwise.
Command:	B CCITT or Bell
Description:	When the modem is configured to allow either option, the modem will select Bell or CCITT modulation for a line speed connection of 300 or 1200 bps. Any other line speed will use a CCITT modulation standard. The parameter value, if valid, is written to S27 bit 6.
Syntax:	B<value>
Defined Values:	<value> Decimal number corresponding to the selected option. 0 Selects CCITT operation at 300 or 1200 bps during Call Establishment and a subsequent connection. (Default.) 1 Selects BELL operation at 300 or 1200 bps during Call Establishment and a subsequent connection.
Result Codes:	OK <value> = 0 or 1. ERROR Otherwise.

Error Control Commands

Command: **+ES**

Error Control and Synchronous Mode Selection

Description:

This extended-format command specifies the initial requested mode of operation when the modem is operating as the originator, optionally specifies the acceptable fallback mode of operation when the modem is operating as the originator, and optionally specifies the acceptable fallback mode of operation when the modem is operating as the answerer. It accepts three numeric subparameters:

Syntax:

+ES=[<orig_rqst>[,<orig_fbk>[,<ans_fbk>]]]

Defined Values:

<orig_rqst> Decimal number which specifies the initial requested mode of operation when the modem is operating as the originator. The options are:

- 0 Initiate call with Direct Mode.
- 1 Initiate call with Normal Mode (also referred to as Buffered Mode) only.
- 2 Initiate V.42 without Detection Phase. If V.8 is in use, disable V.42 Detection Phase.
- 3 Initiate V.42 with Detection Phase. (Default.)
- 4 Initiate MNP.
- 6 Initiate V.80 Synchronous Access Mode when connection is completed, and Data State is entered. (See +ESA and +ITF commands.)
- 7 Initiate Frame Tunneling Mode when connection is complete, and Data Mode is entered.

<orig_fbk> Decimal number which specifies the acceptable fallback mode of operation when the modem is operating as the originator.

- 0 LAPM, MNP, or Normal Mode error control optional. (Default.)
- 1 LAPM, MNP, or Direct Mode error control optional.
- 2 LAPM or MNP error control required; disconnect if error control is not established.
- 3 LAPM error control required; disconnect if error control is not established.
- 4 MNP error control required; disconnect if error control is not established.

<ans_fbk> Decimal number which specifies the acceptable fallback mode of operation when the modem is operating as the answerer or specifies V.80 Synchronous Access Mode.

- 0 Direct Mode.
- 1 Error control disabled, use Normal Mode.
- 2 LAPM, MNP, or Normal Mode error control optional. (Default.)
- 3 LAPM, MNP, or Direct Mode error control optional.
- 4 LAPM or MNP error control required; disconnect if error control is not established.
- 5 LAPM error control required; disconnect if error control is not established.
- 6 MNP error control required; disconnect if error control is not established.
- 8 Initiate V.80 Synchronous Access Mode when connection is completed, and Data State is entered (see +ESA and +ITF commands).
- 9 Initiate Frame Tunneling Mode when connection is complete, and Data Mode is entered.

Examples:

+ES=6 Enable V.80 Synchronous Access Mode originator.
 +ES=6 Enable V.80 Synchronous Access Mode originator.
 +ES=,8 Enable V.80 Synchronous Access Mode answerer.
 +ES=6,,8 Enable V.80 Synchronous Access Mode originator and answerer.
 +ES=3 Enable V.42 with Detection Phase originator. Disable V.80 Synchronous Access Mode originator.
 +ES=,2 Allow LAPM, MNP, or Normal Mode connection answerer. Disable V.80 Synchronous Access Mode answerer.
 +ES=3,,2 Enable V.42 with Detection Phase originator, allow LAPM, MNP, or Normal Mode connection answer. Disable Synchronous Access Mode originator and answerer.

Reporting Current or Selected Values:

Command: **+ES?**

Response: **+ES: <orig_rqst>,<orig_fbk>,<ans_fbk>**

Example: **+ES: 3,0,2** For the default setting.

+ES: 6,0,8 For V.80 Synchronous Access Mode originator and answerer.

Reporting Supported Range of Parameter Values:

Command: **+ES=?**

Response: **+ES: (<orig_rqst> range),(<orig_fbk> range),(<ans_fbk> range)**

Example: **+ES: (0-4,6,7),(0-4),(0-6,8,9)**

Command: +EB Break Handling in Error Control Operation

Description: This extended-format compound parameter controls the break handling in V.42 operation. It accepts three numeric subparameters:
Syntax: +EB=[<break_selection>[,<timed>[,<default_length>]]]
Defined Values: <break_selection> Decimal number 0 specifying that break is to be ignored, i.e., not signaled to remote DCE.
 <timed> Decimal number 0 specifying that any transmitted V.42 L-SIGNAL will not indicate break signal length <default_length> Decimal number 0 specifying that break is not delivered to the DTE.

Reporting Current or Selected Values:
Command: +EB?
Response: +EB: <break_selection>,<timed>,<default_length><CR>
Example: +EB: 0,0,0 For default settings.

Reporting Supported Range of Parameter Values:
Command: +EB=?
Response: +EB: (<break_selection> range),(<timed> range), (default_length range)
Example: +EB: (0),(0),(0)

Command: +ESR Selective Repeat

Description: This extended-format numeric parameter controls the use of the selective repeat (SREJ) option in V.42.
Syntax: +ESR=[<value>]
 Decimal number 0 specifying that SREJ is not used.

Reporting Current or Selected Values:
Command: +ESR?
Response: +ESR: <value>
Example: +ESR: 0 For default setting

Reporting Supported Range of Parameter Values:
Command: +ESR=?
Response: +ESR: (<value>)
Example: +ESR: (0)

Command: +EFCS 32-bit Frame Check Sequence

Description: This extended-format numeric parameter controls the use of the 16-bit or 32-bit frame check sequence (FCS) option in V.42.
Syntax: +EFCS=[<value>]
Defined Values: <value> Decimal number 0 specifying the use of the 16-bit FCS specified in V.42.

Reporting Current or Selected Values:
Command: +EFCS?
Response: +EFCS: <value>
Example: +EFCS: 0 For default setting.

Reporting Supported Range of Parameter Values :
Command: +EFCS=?
Response: +EFCS: (<value> range)
Example: +EFCS: (0)

Command: +ER Error Control Reporting

Description: This extended-format numeric parameter controls whether or not the extended-format +ER: intermediate result code is transmitted from the modem to the DTE. S95 bit 3 is reset to 0 for +ER=0 and is set to a 1 for +ER=1. The more recent setting of +ER or S95 bit 3, and the W command setting, determines the actual error control result code reporting (see S95 Parameter and W Command).
+ER=[<value>] +ER=[<value>] +ER=[<value>] +ER=[<value>]
+ER=[<value>]

Syntax: +ER=[<value>]

Defined Values: <value> A decimal number corresponding to the selected error control option:
0 = Error control reporting disabled (no +ER intermediate result code transmitted). (Default.)
1 = Error control reporting enabled (+ER intermediate result code transmitted).

Reporting Current or Selected Values:
Command: +ER?
Response: +ER: <current value>
Example: +ER: 0 for the default setting

Reporting Supported Range of Parameter Values:
Command: +ER=?
Response: +ER: (<value> range)
Example: +ER: (0,1)

Command: +ER: <type>

Description: The +ER: <type> reported represents the current (negotiated or renegotiated) modem-modem error control type. If enabled, the intermediate result code is transmitted at the point during error control negotiation (handshaking) at which the modem has determined which error control protocol will be used (if any), before the final result code (e.g., CONNECT) is transmitted. The format of this result code is: The +ER intermediate result code, if enabled, is issued after the Modulation report (+MCR and +MRR) and before the Data Compression Report (+DR).

Syntax: +ER: <type>

Defined Values: <type> An alphanumeric code corresponding to the selected protocol.
NONE Error control is not in use.
LAPM V.42 LAPM protocol is in use.
ALT MNP is in use.

Example: +ER: LAPM

Command: +ETBM Call Termination Buffer Management

Description: This extended-format compound parameter controls the handling of data remaining in modem buffers upon call termination. It accepts three numeric subparameters:

Syntax: +ETBM=[<pending_TD>[,<pending_RD>[,<timer>]]]

Defined Values: <pending_TD> Decimal number 0 specifying that disconnect will occur immediately and all buffered transmit data will be discarded when the local DTE requests call disconnection.

<pending_RD> Decimal number 0 specifying that disconnect will occur immediately and all buffered receive data will be discarded when the local DTE requests call disconnection.

<timer> Decimal number 0 specifying that the modem will not attempt to deliver the buffered data before abandoning the attempt and discarding remaining data.

Reporting Current or Selected Values:

Command: +ETBM?

Response: +ETBM: <pending_TD>,<pending_RD>,<timer>

Example: +ETBM: 0,0,0

Reporting Supported Range of Parameter Values:

Command: +ETBM=?

Response: +ETBM: (<pending_TD> range),(<pending_RD> range), (<timer> range)

Example: +ETBM: (0),(0),(0)

Command: \B Transmit Break to Remote

Description: In non-error correction mode, the modem will transmit a break signal to the remote modem with a length in multiples of 100 ms according to parameter specified. If a number in excess of 9 is entered, 9 is used. The command works in conjunction with the \K command.

In error correction mode, the modem will signal a break through the active error correction protocol, giving no indication of the length.

Syntax: \B<value>

Defined Values: <value> Decimal number corresponding to the selected option.

1-9 Break length in 100 ms units. (Default = 3.)

(Non-error corrected mode only.)

Result Codes:

OK If connected in data modem mode.

NO CARRIER If not connected or connected in fax modem mode.

Note: When the modem receives a break from the remote modem, break is passed to the DTE as follows: In non-error correction mode direct, the break length is passed; in non-error correction mode normal and in error correction mode, a 300 ms break is passed.

Command: \K Break Control

Description: Controls the response of the modem to a break received from the DTE or the remote modem or the \B command. The parameter value, if valid, is written to S40 bits 3, 4, and 5.

Syntax: \K<value>

Defined Values: <value> Decimal number corresponding to the selected option.

The response is different in three separate states.

The first state is where the modem receives a break from the DTE when the modem is operating in data transfer mode:

0 Enter on-line command mode, no break sent to the remote modem.

1 Clear data buffers and send break to remote modem.

2 Same as 0.

3 Send break to remote modem immediately.

4 Same as 0.

5 Send break to remote modem in sequence with transmitted data. (Default.)

The second case is where the modem is in the on-line command state (waiting for AT commands) during a data connection, and the \B is received in order to send a break to the remote modem:

0 Clear data buffers and send break to remote modem.

1 Clear data buffers and send break to remote modem. (Same as 0.)

2 Send break to remote modem immediately.

3 Send break to remote modem immediately. (Same as 2.)

4 Send break to remote modem in sequence with data.

5 Send break to remote modem in sequence with data. (Same as 4.) (Default.)

The third case is where a break is received from a remote modem during a non-error corrected connection:

0 Clears data buffers and sends break to the DTE.

1 Clears data buffers and sends break to the DTE. (Same as 0.)

2 Send a break immediately to DTE.

3 Send a break immediately to DTE. (Same as 2.)

4 Send a break in sequence with received data to DTE.

5 Send a break in sequence with received data to DTE. (Same as 4.) (Default.)

Result Codes:

OK 0 to 5.

ERROR Otherwise.

Command: -K**MNP Extended Services**

Description:

Enables or disables conversion of a V.42 LAPM connection to an MNP 10 connection.

The parameter value, if valid, is written to S40 bits 0 and 1.

Syntax:

-K<value>

Defined Values:

<value> Decimal number corresponding to the selected option.

0 Disables V.42 LAPM to MNP 10 conversion. (Default.)

1 Enables V.42 LAPM to MNP 10 conversion.

2 Enables V.42 LAPM to MNP 10 conversion; inhibits MNP Extended Services

initiation during V.42 LAPM answer mode detection phase.

Result Codes:

OK 0 or 2.

ERROR Otherwise.

Data Compression Commands

This section contains parameters to condition modem use of standard ITU-T V.42bis Data Compression Procedures.

Command:	+DS	Data Compression
Description:		This extended-format compound parameter controls the V.42bis data compression function if provided in the modem. It accepts four numeric subparameters:
Syntax:		+DS=[<direction>[,<compr_neg>[,<max_dict>[,<max_string>]]]]
Defined Values:		<direction> Specifies the desired direction(s) of operation of the data compression function; from the DTE point of view. 0 Negotiated; no compression (V.42bis P0=0). 3 both directions, accept any direction (V.42bis P0=11). (Default.) <compr_neg> Specifies whether or not the modem should continue to operate if the desired result is not obtained. 0 Do not disconnect if V.42bis is not negotiated by the remote modem as specified in <direction>. <max_dict> Specifies the maximum number of dictionary entries (2048 entries) which should be negotiated (may be used by the DTE to limit the codeword size transmitted, based on its knowledge of the nature of the data to be transmitted). <max_string> Specifies the maximum string length (32 bytes) to be negotiated (V.42bis P2).
Reporting Current or Selected Values:		Command: +DS? Response: +DS: <direction>,<compr_neg>,<max_dict>,<max_string> Example: +DS: 3,0,2048,32 for the defaults and 2048 entry max dictionary.
Reporting Supported Range of Parameter Values:		Command: +DS=? Response: +DS: (<direction> range),(<compr_neg> range), (<max_dict> range),(<max_string> range) Example: +DS: (0,3),(0),(2048),(32)

Command:	+DS44	V.44 Compression Select
Description:		This extended-format compound parameter controls the V.44 data compression function.
Syntax:		+DS44=[<direction>[,<compress_negotiation>[,<capability>[,<max_codewords_tx>[,<max_codewords_rx>[,<max_string_tx>[,<max_string_rx>[,<max_history_tx>[,<max_history_rx>]]]]]]]]]]]]
Defined Values:		<direction> Decimal number that specifies the desired direction(s) of operation of the data compression function; from the DTE point of view. 0 Negotiated, no compression. 1 Transmit only. 2 Receive only. 3 Both directions, accept any direction. (Default.) <compress_negotiation> Decimal number that specifies whether or not the modem should continue to operate if the desired result is not obtained. 0 Do not disconnect if V.44 is not negotiated by the remote DCE as specified in <direction>. (Default.) 1 Disconnect if V.44 is not negotiated by the remote DCE as specified in <direction>. <capability> Decimal number that specifies the use of stream method, packet method, multi-packet method. 0 Stream method. (Default.) 1 Packet method. 2 Multi-packet method. <max_codewords_tx> Decimal number from 256 to 2048 that specifies the maximum number of codewords which should be negotiated in the transmit direction. (Default = 2048.) <max_codewords_rx> Decimal number from 256 to 2048 that specifies the maximum number of codewords which should be negotiated in the receive direction. (Default = 2048.) <max_string_tx> Decimal number from 32 to 255 that specifies the maximum string length to be negotiated in the transmit direction. (Default = 32.)

<max_string_rx> Decimal number from 32 to 255 that specifies the maximum string length to be negotiated in the receive direction. (Default = 32.)

<max_history_tx> Decimal number from 2048 to 4096 that specifies the maximum size of the history buffer to be negotiated in the transmit direction. (Default = 4096.)

<max_history_rx> Decimal number from 2048 to 4096 that specifies the maximum size of the history buffer to be negotiated in the receive direction. (Default = 4096.)

Reporting Current or Selected Values:

Command: +DS44?

Response: +DS44:<direction>,<compression_negotiation>,<capability>,
<max_codewords_tx>,<max_codewords_rx>,<max_string_tx>,
<max_string_rx>,<max_history_tx>,<max_history_rx>

Example: +DS44:3,0,0,2048,2048,32,32,4096,4096 For the default setting.

Reporting Supported Range of Parameter Values:

Command: +DS44=?

Response: +DS44:(list of supported <direction> values),(list of supported
<compression_negotiation> values),(list of supported <capability> values),(list of
supported <max_codewords_tx> values),(list of supported <max_codewords_rx>
values),(list of supported <max_string_tx> values),(list of supported <max_string_rx>
values),(list of supported <max_history_tx> values),(list of supported <max_history_rx>
values)

Command:	+DR	Data Compression Reporting
Description:		This extended-format numeric parameter controls whether or not the extended-format +DR: intermediate result code is transmitted from the modem to the DTE. S95 bit 5 is reset to 0 for +DR=0 and is set to a 1 for +DR=1. The more recent setting of +DR or S95 bit 5, and the W command setting, determines the actual data compression result code reporting (see S95 Parameter and W Command).
Syntax:		+DR=[<value>]
Defined Values:		<value> decimal number corresponding to the selected option: 0 Data compression reporting disabled (no +DR result code transmitted). 1 Data compression reporting enabled (+DR result code transmitted). (Default.)
Reporting Current or Selected Values:		Command: +DR? Response: +DR: <current value> Example: +DR: 1 For the default setting.
Reporting Supported Range of Parameter Values:		Command: +DR=? Response: +DR: (<value> range) Example: +DR: (0,1)
+DR: <type> Intermediate Result Code:		The +DR: <type> reported represents the current (negotiated or renegotiated) modem-modem data compression type. If enabled, the intermediate result code is transmitted at the point after error control negotiation (handshaking) at which the modem has determined which data compression technique will be used (if any) and the direction of operation. The +DR intermediate result code, if enabled, is issued after the Error Control Report (+ER) and before the final result code (e.g., CONNECT).
The format of this result code is:		
Result Code Syntax:		+DR: <type>
Defined Values:		<type> An alphanumeric code corresponding to the selected option: NONE Data compression is not in use. V42B V.42bis is in use in both directions. V42B RD V.42 bis is in use in receive direction only V42B TD V.42 bis is in use in transmit direction only V44 V.44 is in use in both directions V44 RD V.44 is in use in receive direction only V44 TD V.44 is in use in transmit direction only ALT MNP 5 compression.
Example:		+DR: V42B
Command:	%C	Enable/Disable Data Compression
Description:		Enables or disables data compression negotiation. The modem can only perform data compression on an error corrected link. The parameter value, if valid, is written to S41 bits 0 and 1.
Syntax:		%C<value>
Defined Values:		<value> Decimal number corresponding to the selected option. 0 Disables data compression. Resets S46 bit 1. 1 Enables MNP 5 data compression negotiation. Resets S46 bit 1. 2 Enables V.42 bis data compression. Sets S46 bit 1. 3 Enables both V.42 bis and MNP 5 data compression. Sets S46 bit 1. (Default.)
Result Codes:		OK <value> = 0, 1, 2, or 3. ERROR Otherwise.

V.8/V.8bis Commands

Command:	+A8E	V.8 and V.8bis Operation Controls
Description:		<p>This command is defined for two conditions: as a parameter while the modem is on-hook, and as an action command while the modem is off-hook. If enabled, V.8 negotiation does not preclude simultaneous implementation of other negotiation means (e.g., V.8bis, V.18, V.32bis Annex A).</p> <p>This command is a compound parameter if issued while the modem is on-hook, used to precondition V.8 and V.8bis originating and answering operation. It is issued by the DTE before the Dial (D) or Answer (A) command, regardless of the state of the +FCLASS parameter.</p> <p>This command is an action command if issued while the modem is off-hook, to (re)start V.8 or V.8bis negotiation. For example, if initial V.8 negotiation failed, but subsequent T.30 negotiation indicated V.8 capability, this command may be used to initiate V.8 negotiation.</p>
Syntax:		+A8E=<v8o>,<v8a>,<v8cf>[,<v8b>][,<cfrange>][,<protrange>]
Defined Values:		<p><v8o> Decimal number which enables/disables issuance of +A8x indications during modem-controlled V.8 origination negotiation.</p> <p>1 Enable DCE-controlled V.8 origination negotiation without +A8x indications. (Default.)</p> <p>6 Enable DCE-controlled V.8 origination negotiation with +A8x indications.</p> <p><v8a>= Decimal number which enables/disables issuance of +A8x indications during modem-controlled V.8 answer negotiation.</p> <p>1 Enable DCE-controlled V.8 answer negotiation without +A8x indications. (Default.)</p> <p>5 Enable DCE-controlled V.8 answer negotiation with +A8x indications.</p> <p><v8cf>= Set the V.8 CI signal call function to the hexadecimal octet XY.</p> <p>00 (Default.)</p> <p>21</p> <p>C1</p> <p><v8b>= Decimal number which enables/disables V.8bis negotiation.</p> <p>0 Disable V.8bis negotiation.</p> <p>1 Enable V.8bis negotiation. (Default.)</p> <p><cfrange>= “<string of values>”. Applicable only for <v8a>=5. Not supported.</p> <p>< protrange >= “<string of values>”. Applicable only for <v8a>=5. Not supported.</p> <p>Default values: 1,1,00,1,0,0</p> <p>The ATD and ATA commands behave as specified in V.250, and +A8n indications are not generated by the modem.</p> <p>For subparameter values <v8o>=6 and <v8a>=5, the +A8l indications are issued during the course of the V.8 session to notify the DTE when the relevant V.8 signals are received.</p>
Reporting Current or Selected Values:		<p>Command: +A8E?</p> <p>Response: +A8E: <v8o>,<v8a>,<v8cf>[,<v8b>][,<cfrange>][,<protrange>] Example: +A8E: 1,1,00,1,0,0 For the defaults</p>
Reporting Supported Range of Parameter Values:		<p>Command: +A8E=?</p> <p>Response: +A8E: (<v8o> range),(<v8a> range),(<v8cf> in octets), (<v8b> range),(<cfrange>),(<protrange>)</p> <p>Example: +A8E: (1,6),(1,5),(0,21,C1),(0,1),(0),(0)</p>
Command:	+A8I	CI Signal Indication
Description:		<p>This indication is issued by an answering modem, if +A8E,<v8a> .0, to indicate detection of a V.8 CI signal, and report the recovered Call Function octet(s).</p>
Indication Syntax:		+A8I:<v8cf><CR>
Defined Values:		<v8cf> A hexadecimal code octet representation of those Call Function octet(s). +A8I:0 indicates that the modem timed out waiting for CI.
Example:		+A8I:0 The modem timed out waiting for CI. +A8I:X YYY

Diagnostic Commands

Command:	#UD	Last Call Status Report
Description:		<p>#UD is an action command requesting reporting of logged operation events. It does not take parameters and must be the last command in the command line.</p> <p>The modem logs aspects of their operation for each call, and saves these results until cleared by one of the following events:</p> <ol style="list-style-type: none"> 1. Power off. 2. Hard reset (e.g., negate DTR with &D3 set; reset button). 3. Soft reset = ATZ or AT&F. 4. ATD command issued. 5. ATA command issued. 6. Automatic answer (e.g., set register S0>0 and ring detected). <p>These results are NOT cleared by changing DTR, V.24 circuit 108.2, if &D0, &D1 or &D2.</p>
Data Call State Model:		<p>For purposes of this command, there are four data call states, and associated status issues:</p> <ul style="list-style-type: none"> • Call Setup <ul style="list-style-type: none"> -Calling DCE: get dial tone, generate dial digits, detect call progress signals. -Answering DCE: detect ringing, detect CallerID, etc. • Negotiation <ul style="list-style-type: none"> -V.25 calling tone/answer tone exchanges -V.8 or V.8bis call function negotiations -V-series modem carrier detection and training -Modem-to-modem protocols (e.g., V.42, V.42bis). • Data Transfer <ul style="list-style-type: none"> -Bit-error rates, for each direction -Rate renegotiation -Retraining • Call Termination <ul style="list-style-type: none"> -protocol disconnect signals -carrier disconnect signals -loss of carrier -excessive error rates
Command Syntax:		<p>In response to this command, the modem will report one or more lines of information text as defined below. Information text format conforms to V.250; each line is preceded by a <CR><LF> pair, and terminated by <CR><LF>. (CR and LF characters may be changed by writing new values to the contents of registers S3 and S4, respectively.) The modem may generate a single line or multiple lines, followed by a standard OK final result code. For example, if call setup failed, only that result is useful. Each information text line is formatted as follows, including one or more key=value pairs:</p>
Syntax:		#UD
Response:		DIAG <token key=value [[key=value] [key=value]] ...>
Defined Values:		DIAG 5 hexadecimal characters (44h, 49h, 41h, 47h, 20h) < Left angle bracket (less than sign) (3Ch) token Unique 32-bit hexadecimal string 2A4D3263(32h, 4h1, 34h, 44h, 33h, 32h, 36h, 33h) space space character (20h) Key One- or two-digit hexadecimal number (see Key in Table 3-4) = Equal sign (3Dh) Value Any string as defined below (Table 3-4 - Table 3-9 as appropriate) > Right angle bracket (greater than sign) (3Eh)
		<p>Unless otherwise noted, all values are hexadecimal numbers. Any numeric values from tables in ITU V.58 are converted to hexadecimal. Multi-digit values are reported MSD first. Leading 0's may be deleted. See examples in Table 3-13.</p>

Monitoring an Active Connection

This command is intended for use after call termination. However, codes are defined so that a modem can respond before the first call is placed, and during a call for live monitoring purposes. For example, key 60, call termination, has value 1 defined, indicating that the call is still in progress.

There are at least two ways to do this. First, the DTE could switch the modem to On-Line command state, issue the command, capture the responses and then issue an ATO command. For smoother on-line monitoring, in-band means defined in ITU V.80 are recommended if available in the modem. If V.80 methods are used, each response line shall be a separate extended in-band message.

Notes for Tables

1. The modem may insert a delay (e.g., 10 ms) between information text lines.
2. The code tables include values for data and fax calls. Some of the codes are applicable only to data calls (e.g., data compression), some are applicable only to call origination (e.g., busy, answering signal detection) and some are applicable only to the answering modem (e.g., calling signal detection).

callCleared codes from 3.6.4/V.58-1994

callCleared: indicates that the DCE has gone on-hook and that the previously existing network connection has been cleared. These value are hex, converted from decimal in V.58. callCleared codes are described in Table 3-12.

Table 3-4. AT#UD Last Call Status Report Format

Key	Value(s)	Definition
0	2 digits	Diagnostic Command Specification revision number, digit.digit
1	Table 3-5	Call Setup Result code
2	Table 3-6	Multi-media mode
3	Table 3-7	DTE-DCE interface mode
4	String	V.8 CM octet string, same format as V.250, in quotes
5	String	V.8 JM octet string, same format as V.250, in quotes
10	0-2F	Received signal power level, in –dBm (0-43)
11	0-1F	Transmit signal power level, in –dBm (e.g., 0-17)
12	0-64	Estimated noise level, in –dBm (e.g., 10-90)
17	0-FFF	Round Trip delay, in units of ms
18	Table 3-8	V.34 INFO bit map
20	Table 3-9	Transmit Carrier Negotiation Result
21	Table 3-9	Receive Carrier Negotiation Result
22	0-1F40	Transmit Carrier symbol rate (0-8000) in symbol/s
23	0-1F40	Receive Carrier symbol rate (0-8000) in symbol/s
24	0-FA0	Transmit Carrier frequency (0-4000) in Hz
25	0-FA0	Receive Carrier frequency (0-4000) in Hz
26	0-FA00	Initial transmit carrier data rate (0-64000) in bit/s
27	0-FA00	Initial receive carrier data rate (0-64000) in bit/s
30	0-FF	Temporary carrier loss event count
31	0-FF	Carrier Rate re-negotiation event count
32	0-FF	Carrier Retrains requested
33	0-FF	Carrier Retrain requests granted
34	0-FA00	Final transmit carrier data rate in bit/s
35	0-FA00	Final receive carrier data rate in bit/s
40	Table 3-10	Protocol Negotiation Result
41	0-400	Error Control frame size in bytes
42	0-FF	Error control link timeouts in transmission
43	0-FF Error	control link NAKs received
44	Table 3-11	Compression Negotiation Result
50	0-2	Transmit flow control: 0 = off; 1 = DC1/DC3; 2 = V.24 circuit 106/133
51	0-2	Receive flow control: 0 = off; 1 = DC1/DC3; 2 = V.24 circuit 106/133
52	0-FFFFFFFF	Transmit characters sent from DTE
53	0-FFFFFFFF	Received characters sent to DTE
54	0-FFFF	Transmit characters lost (data overrun errors from DTE)
55	0-FFFF	Received characters lost (data overrun errors to DTE)
56	0-FFFFFFFF	Transmit I- Frame count, if error control protocol running
57	0-FFFFFFFF	Received I-Frame count, if error control protocol running
58	0-FFFF	Transmit I-Frame error count, if error control protocol running
59	0-FFFF	Received I- Frame error count, if error control protocol running
60	Table 3-12	Termination Cause
61	0-FF Call	Waiting event count

Table 3-5. Call Setup Result Codes

Code	Definition
0	No previous call (modem log has been cleared since any previous calls)
1	No dial tone detected
2	Reorder signal detected, network busy
3	Busy signal detected
4	No recognized signal detected (e.g., no signal, or nothing recognizable)
5	Voice detected * if this is a voice modem (e.g., V.253) operating in voice mode (e.g., +FCLASS=8.0)
7	Data Answering signal detected (e.g., V.25 ANS, V.8 ANSam)
8	Data Calling signal detected (e.g., V.25 CT, V.8 CI)
9	Fax Answering signal detected (e.g., T.30 CED, DIS)
A	Fax Calling signal detected (e.g., T.30 CNG)
B	V.8bis signal detected

Table 3-6. Multimedia Modes

Code	Definition
0	Data Only
1	Fax Only
2	Voice
9	Video-telephony, H.324
A	Other V.80 call

Table 3-7. DTE-DCE modes

Code	Definition
0	Async data
1	V.80 transparent synchronous mode
2	V.80 framed synchronous mode

Table 3-8. V.34 INFO bit report

Bits	Source bits	Definition
31-30	INFO0 bit 20; 0	
20-29	INFOc bits 79-88	
16-19	INFOc bits 26-29 or 35-38 or 44- 47 or 53-56- or 62-65 or 71-74	
	Pre-emphasis field, selected by the symbol rate chosen	
12-15	INFOa bits 26-29	
10-11	MP bit 50; 0	
0-9	INFOa bits 40-49.	

Table 3-9. gstnModulationSchemeActive from 3.7.2/V.58

Value	Description
0	V.17 (G3 Fax call)
1	V.21
2	V.22
3	V.22bis
4	V.23 Constant Carrier (1200/75)
8	V.27ter (G3 Fax call)
9	V.29 HD (G3 Fax call)
A	V.32
B	V.32bis
C	V.34
E	V.90 and V.92
81	K56flex
84	Bell 212A
85	Bell 103

Table 3-10. errorControl Active from 3.5.2/V.58

Value	Description
0	Disable/none
1	V.42 LAPM
2	V.42 Alternative protocol (MNP™)
80	MNP10™

Table 3-11. compressionActive from 3.2.2/V.58

Value	Description
0	None
1	V.42bis and V.44
80	MNP5™

Table 3-12. callCleared codes from 3.6.4/V.58-1994

Value	Description	Notes
0	CauseUnidentified	Call setup issues
1	No Previous call	Not in V.58
2	Call is still in progress	Not in V.58
3	Call Waiting signal detected	Not in V.58, only if modem can detect it
4	Delayed	Same as value 2A, CallAttemptsLimitExceeded
19	InactivityTimerExpired	
1F	cct108isOffInhibitsDial	DTR low
20	cct108turnedOff	DTR drop
29	BlacklistedNumber	
2A	CallAttemptsLimitExceeded	Same as “Delayed”, see ETS 300 001
2B	ExtensionPhoneOff-hook	If extension detection supported
2C	CallSetupFailTimerExpired	e.g., S7 timeout
2D	IncomingCallDetected	If incoming call while sending dial command.
2E	LoopCurrentInterrupted	
2F	NoDial tone	
31	ReorderTone	Fast busy
33	EngagedTone	Busy
34	LongSpaceDisconnect	And if modem program to abort on long space
3C	CarrierLost	Signal Converter
3D	TrainingFailed	
3E	NoModulationinCommon	
3F	RetrainFailed	
40	RetrainAttemptCountExceeded	
41	GstnClearDownReceived	
42	FaxDetected	If this was not a fax call attempt
46	InTestMode	Test
50	AnyKeyAbort	Call Control
51	DteHangupCommand	If ATH was used to terminate the previous call.
52	DteResetCommand	If ATZ was used to terminate the previous call.
5A	FrameReject	Error Control
5B	NoErrorControlEstablished	Error control was required
5C	ProtocolViolation	
5D	n400exceeded	LAPM retransmission Count Timer
5E	NegotiationFailed	
5F	DisconnectFrameReceived	
60	SabmeFrameReceived	
64	LossOfSynchronization	Data Compression

Example Modem Response and Usage

Example #UD command response are shown in Table 3-13.

Table 3-13. Completed Data Call, with some errors and rate retrain during the call

Modem Response Line	Description
DIAG <2A4D3263 0=09>	This is version 0.9
DIAG <2A4D3263 1=06 2=0 3=0>	Data Answer signal detected; Data only; Character async
DIAG <2A4D3263 5="C14513902A" 6="A145">	V.8 Call Menu indicates: V.8 Joint Menu selects:
DIAG <2A4D3263 10=1F 11=0C 12=52>	Receive level = -31 dBm; transmit level = -12 dBm; noise level = -82 dBm
DIAG <2A4D3263 14=03 15=05 16=10>	Far end echo delay in milliseconds; Far end echo loss in dB; Near end echo loss = 16 dB
DIAG <2A4D3263 20=C 22=780 24=0C80 26=79E0>	Transmitter: V.34 training completed; V.34 carrier frequency = 1920; V.34 symbol rate = 3200; initial transmit rate is 31200 bit/s
DIAG <2A4D3263 21=D 25=1F40 27=DAC0>	Receiver: V.90 training completed; V.90 symbol rate = 8000; initial receive rate is 56000 bit/s
DIAG <2A4D3263 30=00 31=03 32=01 33=01>	No carrier loss events, 3 carrier rate renegotiations attempted; 1 carrier retrain requested; 1 carrier retrain granted
DIAG <2A4D3263 34=7080 35=CB20>	Final transmit rate is 28800 bit/s; final receive rate is 52000 bit/s
DIAG <2A4D3263 40=1 41=100>	LAPM negotiation completed; frame size = 256
DIAG <2A4D3263 42=0 43=0>	No error control timeout or link NAKs
DIAG <2A4D3263 44=1 45=400>	V.42bis data compression used; dictionary size = 1024
DIAG <2A4D3263 50=2 51=2>	Hardware transmit and receive flow control
DIAG <2A4D3263 52=343CC 54=0>	213964 DTE characters transmitted, w/o underrun
DIAG <2A4D3263 53=7230E6 55=47>	7483622 DTE characters received, 71 characters lost due to receive data overrun
DIAG <2A4D3263 56=29D 58=0001>	597 (decimal) frames transmitted, with 1 frame error
DIAG <2A4D3263 58=2A4B 59=0004>	10827 (decimal) frames received, with 4 frame errors
DIAG <2A4D3263 60=51>	Local PC initiated hangup

Compatibility Commands

Command:	&L	Leased Line Operation
Description:		This command requests leased line or dial-up operation. This command is provided for compatibility only; no mode change is performed, dial-up operation continues. The OK response is returned for a valid parameter, but no other action is performed. The parameter value, if valid, is written to S27 bit 2.
Syntax:		&L<value>
Defined Values:		<value> Decimal number corresponding to the selected option. 0 Requests dial-up operation. Dial-up operation continues.
Result Codes:		OK 0. ERROR Otherwise.
Command:)M	Enable Cellular Power Level Adjustment
Description:		This command is included for compatibility only and has no effect other than returning a result code.
Syntax:)M<value>
Defined Values:		<value> Decimal number corresponding to the selected option. 0)M0 command. 1)M1 command. 2)M2 command.
Result Codes:		OK 0 to 2. ERROR Otherwise.
Command:	@M	Initial Cellular Power Level Setting
Description:		This command is included for compatibility only and has no effect other than returning a result code.
Syntax:		@M<value>
Defined Values:		<value> Decimal number corresponding to the selected power setting. 0 @M0 command. . . 30 @M30 command.
Result Codes:		OK 0 to 30. ERROR Otherwise.
Command:	:E	Compromise Equalizer Enable Command
Description:		This command is included for compatibility only and has no effect other than returning a result code.
Syntax:		:E<value>
Defined Values:		<value> Decimal number corresponding to the selected option. 0 :E0 command. 1 :E1 command.
Result Codes:		OK 0 or 1. ERROR Otherwise.

FastConnect Commands

Command:	\$F	FastConnect Control
Description:		This command allows configuring of the client modem to connect to a central site modem that supports non-standard V.22 and V.22 bis FastConnect protocols.
Syntax:		\$F<n>
Defined Values:		<n> Decimal number which specifies the initial requested mode of operation when the modem is operating as the originator. The options are: 0 Normal connection (Default) 1 FastConnect without answer tone 2 Reserved 3 FastConnect with answer tone

V.92 +P and –Q Commands

This section describes the +P (PCM DCE) and –Q commands and parameters used to control the V.92 Mode operation.

Command:	+PCW	Call Waiting Enable
Description:		This command controls the operation of the modem in the presence of call waiting.
Syntax:		+PCW=<value>
Defined Values:		<value> Decimal number corresponding to the selected operation. 0 Request modem-on-hold if enabled by +PMH and collect caller ID information if enabled by +VRID. Toggle V.24 circuit 125. (Default.) 1 Hang-up. 2 Ignore call waiting.
Result Codes:		OK <value> = 0, 1, or 2. ERROR Otherwise.
Reporting Selected Value(s):		Command: +PCW? Response: +PCW: <value> Example: +PCW: 0 For the default setting.
Reporting Supported Range of Parameter Values:		Command: +PCW=? Response: +PCW: (<value> range) Example: +PCW: (0,1,2)

Command:	+PMH	Modem-on-Hold Enable
Description:		This command controls the selection of modem-on-hold in the modem. The action of the modem in response to modem-on-hold events is determined by the state of this command as well as the state of a negotiated handshake with a V.92-compliant server in V.92 Mode.
Syntax:		+PMH=<value>
Defined Values:		<value> Decimal number corresponding to the selected operation. 0 Modem-on-hold enabled in V.92 Mode. (Default.) 1 Disabled modem-on-hold.
Result Codes:		OK 0 or 1 in V.92 Mode (see the +MS command) ERROR Otherwise.
Reporting Current or Selected Value:		Command: +PMH? Response: +PMH: <current value> Example: +PMH: 0 For the default setting.
Reporting Supported Range of Parameter Values:		Command: +PMH=? Response: +PMH: (<value> range) Example: +PMH: (0,1)

Command: +PMHR Initiate Modem-on-Hold

Description: This command requests the modem to initiate or to confirm a modem-on-hold procedure. The modem will return ERROR if modem-on-hold is not enabled or if the modem is in an idle condition. The modem will return the string response +PMHR: <value> where <value> is a decimal value corresponding to the status of the modem's hold exchange procedure as defined below. This response may be delayed depending upon the context under which the +PMHR command is made, i.e., if the +PMHR is in response to an incoming modem-on-hold or if it is initiating a request.

Note: If modem-on-hold is enabled but the remote server does not support V.92 then the modem will always report 0 to show that the hold request is denied.

Syntax: +PMHR

Response: +PMHR:<value>

<value> Decimal number corresponding to the maximum hold time the server or hold-granting modem will allow.

0 V.92 MOH request denied or not available.

1 MOH with 10 second timeout Granted.

2 MOH with 20 second timeout Granted.

3 MOH with 30 second timeout Granted.

4 MOH with 40 second timeout Granted.

5 MOH with 1 minute timeout Granted.

6 MOH with 2 minute timeout Granted.

7 MOH with 3 minute timeout Granted.

8 MOH with 4 minute timeout Granted.

9 MOH with 6 minute timeout Granted.

10 MOH with 8 minute timeout Granted.

11 MOH with 12 minute timeout Granted.

12 MOH with 16 minute timeout Granted.

13 MOH with indefinite timeout Granted.

Result Codes: OK 0-13 in V.92 Mode (+MS=V92)

ERROR Otherwise

Command: +PMHT Modem-on-Hold Timer

Description: This command controls whether or not the modem will grant or deny a modem-on-hold (MOH) request as well as setting the MOH Timeout value.

Syntax: +PMHT=<value>

Defined Values: <value> Decimal number corresponding to selected setting.

0 Deny V.92 modem-on-hold Request (Default.)

1 Grant MOH with 10 second timeout

2 Grant MOH with 20 second timeout

3 Grant MOH with 30 second timeout

4 Grant MOH with 40 second timeout

5 Grant MOH with 1 minute timeout

6 Grant MOH with 2 minute timeout

7 Grant MOH with 3 minute timeout

8 Grant MOH with 4 minute timeout

9 Grant MOH with 6 minute timeout

10 Grant MOH with 8 minute timeout

11 Grant MOH with 12 minute timeout

12 Grant MOH with 16 minute timeout

13 Grant MOH with indefinite timeout

Result Codes: OK 0-13 in V.92 Mode (+MS=V92)

ERROR Otherwise

Reporting Current or Selected Values:

Command: +PMHT?

Response: +PMHT: <value>

Example: +PMHT: 0 For the default setting.

Reporting Supported Range of Parameter Values:

Command: +PMHT=?

Response: +PMHT: (<value> range)

Example: +PMHT: (0,1,2,3,4,5,6,7,8,9,10,11,12,13)

Command:	+PIG	PCM Upstream Ignore
Description:		This command controls the selection of PCM upstream in the modem. The actual state of PCM upstream is determined by the state of this command as well as the state of a negotiated handshake with a V.92-compliant server in V.92 Mode.
Syntax:		+PIG=<value>
Defined Values:		<value> Decimal number corresponding to the selected operation. 0 Enable PCM upstream negotiation. 1 Disable PCM upstream negotiation. (Default.)
Result Codes:		OK 0 or 1 in V.92 Mode (+MS=V.92) ERROR Otherwise
Reporting Selected Value(s)		Command: +PIG? Response: +PIG: <value> Example: +PIG: 1 For the default setting.
Reporting Supported Range of Parameter Values		Command: +PIG=? Response: +PIG: (<value> range) Example: +PCW: (0,1)
Command:	+PMHF	V.92 Modem-on-Hold Hook Flash
Description:		This command causes the modem to initiate the flash hook sequence when in the modem-on- hold procedure. This enables switching to the second call (incoming or outgoing). This command applies only to V.92 modem-on-hold. There are no parameters associated with this command.
Syntax:		+PMHF
Result Code:		OK When the modem completes the flash hook sequence. ERROR If this command is initiated and the modem is not on hold.
Command:	+PQC	V.92 Phase 1 and Phase 2 Control
Description:		This command controls the global enabling or disabling of the V.92 shortened Phase 1 and Phase 2 startup procedures. This command is used in conjunction with the +PSS command.
Syntax:		+PQC=<value>
Defined Values:		<value> Decimal number corresponding to the selected setting. 0 Enable Short Phase 1 and Short Phase 2. (Default.) 1 Enable Short Phase 1 only. 2 Not supported. 3 Disable Short Phase 1 and Short Phase 2.
Result Codes:		OK 0, 1, or 3 in V.92 Mode (+MS=V.92) ERROR Otherwise
Reporting Selected Values:		Command: +PQC? Response: +PQC: <value> Example: +PQC: 0
Reporting Supported Range of Parameter Values:		Command: +PQC=? Response: +PQC: (<value> range) Example: +PQC: (0,1,3)

Command:	+PSS	Use Short Sequence
Description:		This command causes a calling modem to force either a V.92 short or full startup sequence as defined by the +PQC command on the next and subsequent connections.
Syntax:		+PSS=<value>
Defined Values:		<value> Decimal number corresponding to the selected sequence. 0 The modems decide whether or not to use the short startup procedures. The short startup procedures can only be used if enabled by the +PQC command. (Default.) 1 Reserved. 2 Forces the use of the full startup procedures on the next and subsequent connections independent of the setting of the +PQC command.
Result Codes:		OK 0 - 2 in V.92 Mode (+MS=V.92) ERROR Otherwise
Reporting Selected Values:		Command: +PSS? Response: +PSS: <value> Example: +PSS: 0 For the default <value>.
Reporting Supported Range of Parameter Values:		Command: +PSS=? Response: +PSS: (<value> range) Example: +PSS: (0,1,2)
Command:	-QCPC	Force Full Startup Procedure Next Connection
Description:		This command causes the modem to use full startup procedures on the next connection attempt regardless of the setting of the +PQC command. After this attempt, the modem will select the startup procedure as defined by the +PQC command. If a shortened startup procedure is enabled by the +PQC command, then the quick connect profile will also be updated on the next connection attempt.
Syntax:		-QCPC
Result Code:		OK In V.92 Mode (+MS=V.92) ERROR Otherwise
Command:	-QCPS	Enable Quick Connect Profile Save
Description:		This command controls whether or not the modem will save the generated quick connect profile.
Syntax:		-QCPS=<value>
Defined Values:		<value> Decimal number corresponding to the desired operation. 0 Do not allow the quick connect profile to be saved. 1 Allow the quick connect profile to be saved. (Default.)
Result Codes:		OK 0 or 1 in V.92 Mode (+MS=V.92) and quick connect is enabled (+PSS = 0) ERROR Otherwise
Reporting Selected Value(s):		Command: -QCPS? Response: -QCPS: <value> Example: -QCPS: 1 For the default setting.
Reporting Supported Range of Parameter Values:		Command: -QCPS=? Response: -QCPS: (<value> range) Example: -QCPS: (0,1)

S-Parameters

The S-Parameters are summarized in Table 3-14 along with their default values; registers denoted with an '*' may be stored in one of the two user profiles by entering the &W command. One of these profiles may be loaded at any time by using the Z command. Registers or register fields quoted as "reserved" are reserved for current or future use by the firmware, or are permanently overridden by PTT limitations.

All bit-mapped registers are read-only. The appropriate AT command which controls the relevant bits in the S-Parameter should be used to change the value.

S - Read/Write S-Parameter

The modem selects an S-Parameter, performs an S-Parameter read or write function, or reports the value of an S-Parameter.

n Establishes S-Parameter n as the last register accessed.

n=v Sets S-Parameter n to the value v.

n? Reports the value of S-Parameter n.

The parameter n can be omitted, in which case the last S-Parameter accessed will be assumed. The S can be omitted for AT= and AT?, in which case the last S-Parameter accessed will be assumed. For example:

ATS7 establishes S7 as the last accessed register.

AT=40 sets the contents of the last register accessed to 40.

ATS=20 sets the contents of the last register accessed to 20.

If the number "n" is outside the range of the S-Parameters available, the modem will return the ERROR message. If the value "v" is outside the range permitted for a given S-Parameter, the modem will return the ERROR message. Input and output are always in decimal format. Note that some S-Parameters are read-only.

In some cases, writing to the S-Parameter will appear to be accepted but the value will not actually be written.

Due to country restrictions, some commands will be accepted, but the value may be limited and replaced by a maximum or minimum value.

Factory Defaults

The factory default values are stored in ROM and are loaded into the active configuration at power up or by the ATZ command. In addition, the designated default profile is subsequently loaded, and may change some of the factory default values. The designated default profile can be changed by entering the &Y command where n is one of the two possible user profiles.

The defaults shown are those used by Conexant in factory profiles zero and one. These may be overwritten by the OEM prior to placing the firmware in PROM. Minimum and maximum values may also be imposed in response to country PTT requirements.

The default values shown in Table 3-14 may vary by modem firmware configuration. Consult the MCU firmware release notes for exact configuration.

The factory default values may be loaded at any time by entering the &Fn command.

Table 3-14. S-Parameter Summary

Register	Function	Range	Units	Saved	Default**
S0	Rings to Auto-Answer	0-255	Rings	*	0
S1	Ring Counter	0-255	Rings		0
S2	Escape Character	0-255	ASCII	*	43
S3	Carriage Return Character	0-127	ASCII		13
S4	Line Feed Character	0-127	ASCII		10
S5	Backspace Character	0-255	ASCII		8
S6	Wait Time before Blind Dialing or for Dial Tone	2-255	s	*	2
S7	Wait Time for Carrier, Silence, or Dial Tone	1-255	s	*	50
S8	Pause Time for Dial Delay Modifier	2-255	s	*	2
S9	Carrier Detect Response Time	1-255	0.1 s	*	6
S10	Lost Carrier To Hang Up Delay	1-255	0.1 s	*	14
S11	DTMF Tone Duration	50-255	0.001 s	*	95
S12	Escape Prompt Delay (EPD)	0-255	0.02 s	*	50
S14	General Bit Mapped Options Status	-	-		138 (8Ah)
S16	Test Mode Bit Mapped Options Status	-	-		0
S19	Reserved	-	-		0
S20	Reserved	-	-		0
S21	V.24/General Bit Mapped Options Status	-	-		52 (34h)
S22	Speaker/Results Bit Mapped Options Status	-	-		117 (75h)
S23	General Bit Mapped Options Status	-	-		0
S24	Sleep Inactivity Timer	0-255	s		0
S25	Delay to DTR Off	0-255	s or 0.01 s		5
S26	RTS-to-CTS Delay	0-255	0.01 s		1
S27	General Bit Mapped Options Status	-	-		73 (49h)
S28	General Bit-Mapped Options Status	-	-		0
S29	Flash Dial Modifier Time	0-255	10 ms		70
S30	Disconnect Inactivity Timer	0-255	10 s		0
S31	General Bit-Mapped Options Status	-	-		192 (C0h)
S36	LAPM Failure Control	-	-	*	7
S38	Delay Before Forced Hangup	0-255	s		20
S39	Flow Control Bit Mapped Options Status	-	-		3
S40	General Bit-Mapped Options Status	-	-	*	104 (68h)
S41	General Bit-Mapped Options Status	-	-	*	195 (C3h)
S46	Data Compression Control	-	-	*	138
S48	V.42 Negotiation Control	-	-		7
S86	Call Failure Indication	0-26	-		21
S95	Extended Result Codes Control	-	-	*	0
S210	V.34 Symbol Rate	0-255	-		13 (0Dh)

* Register value may be stored in one of two user profiles with the &W command.

S-Parameters Definitions

S0 - Number of Rings to Auto-Answer

S0 sets the number of the rings required before the modem automatically answers a call.

Setting this parameter to zero disables auto-answer mode.

Range: 0-255 rings

Default: 0

S1 - Ring Counter

S1 is incremented each time the modem detects a ring signal on the telephone line. S1 is cleared if no rings occur over an eight second interval.

Range: 0-255 rings

Default: 0

S2 - Escape Character

S2 holds the decimal value of the ASCII character used as the escape character. The default value corresponds to an ASCII '+'. A value over 127 disables the escape process, i.e., no escape character will be recognized.

Range: 0-255, ASCII decimal

Default: 43 (+)

S3 - Carriage Return Character

S3 sets the command line and result code terminator character. Pertains to asynchronous operation only.

Range: 0-127, ASCII decimal

Default: 13 (Carriage Return)

S4 - Line Feed Character

S4 sets the character recognized as a line feed. Pertains to asynchronous operation only. The Line Feed control character is output after the Carriage Return control character if verbose result codes are used.

Range: 0-127, ASCII decimal

Default: 10 (Line Feed)

S5 - Backspace Character

S5 sets the character recognized as a backspace. Pertains to asynchronous operation only. The modem will not recognize the Backspace character if it is set to a value that is greater than 32 ASCII. This character can be used to edit a command line. When the echo command is enabled, the modem echoes back to the local DTE the Backspace character, an ASCII space character and a second Backspace character; this means a total of three characters are transmitted each time the modem processes the Backspace character.

Range: 0-32, ASCII decimal

Default: 8 (Backspace)

S6 - Wait Time before Blind Dialing or for Dial Tone

S6 operation is country dependent.

1. Sets the length of time, in seconds, that the modem will wait before starting to dial after going off-hook when blind dialing. This operation, however, may be affected by some ATX options according to country restrictions. The "Wait for Dial Tone" call progress feature (*W* dial modifier in the dial string) will override the value in register S6. (US models.)
2. Sets the length of time, in seconds, that the modem will wait for dial tone when encountering a "W" dial modifier before returning NO DIAL TONE result code. (*W* class.) The modem always pauses for a minimum of 2 seconds, even if the value of S6 is less than 2 seconds.

Range: 2-255 seconds

Default: 2

S7 - Wait Time for Carrier, Silence, or Dial Tone

S7 operation is country dependent.

1. Sets the length of time, in seconds, that the modem will wait for carrier before hanging up. The timer is started when the modem finishes dialing (originate), or 2 seconds after going off-hook (answer). In originate mode, the timer is reset upon detection of answer tone if allowed by country restrictions.
2. Sets the length of time, in seconds, that modem will wait for silence when encountering the @ dial modifier before continuing with the next dial string parameter.
3. Sets the length of time, in seconds, that the modem will wait for dial tone when encountering a "W" dial modifier before continuing with the next dial string parameter. (US models.)

Range: 1-255 seconds

Default: 50

S8 - Pause Time For Dial Delay

S8 sets the time, in seconds, that the modem must pause when the "," dial modifier is encountered in the dial string.

Range: 2-255 seconds

Default: 2

S9 - Carrier Detect Response Time

S9 is supported for backwards compatibility only. No value can be written. Responds with default value.

Range: 6 tenths of a second

Default: 6 (0.6 second)

S10 - Lost Carrier To Hang Up Delay

S10 sets the length of time, in tenths of a second, that the modem waits before hanging up after a loss of carrier. This allows for a temporary carrier loss without causing the local modem to disconnect. When register S10 is set to 255, the modem functions as if a carrier is always present.

The actual interval the modem waits before disconnecting is the value in register S10 minus the value in register S9. Therefore, the S10 value must be greater than the S9 value or else the modem disconnects before it recognizes the carrier.

Range: 1-255 tenths of a second

Default: 14 (1.4 seconds)

Note: For Call Waiting detection, if the modem is set to US country code and S10 >=16, then the modem will detect the Call Waiting tone and hang-up the line. If S10 <16, the modem will not detect Call Waiting tone.

S11 - DTMF Tone Duration

S11 operation is country dependent.

1. For US models, S11 sets the duration of tones in DTMF dialing (has no effect on pulse dialing).
2. For W-class models, S11 is a country parameter.

Range: 50-255 milliseconds

Default: 95 (95 milliseconds)

S12 - Escape Prompt Delay (EPD)

S12 defines the maximum period, in fiftieths of a second, allowed between receipt of the last character of the three escape character sequence from the DTE and sending of the OK result code to the DTE. If any characters are detected during this time, the OK will not be sent. Sending of the OK result code does not affect entry into command mode.

Range: 0-255 1/50 of a second

Default: 50 (1 second)

S14 - General Bit Mapped Options Status

S14 indicates the status of command options.

Default: 138 (8Ah) (10001010b)
Bit 0 This bit is ignored.
Bit 1 Command echo (En)
0 = Disabled (E0)
1 = Enabled (E1) (Default.)
Bit 2 Quiet mode (Qn)

- 0 = Send result codes (Q0) (Default.)
- 1 = Do not send result codes (Q1)
- Bit 3 Result codes (Vn)
 - 0 = Numeric (V0)
 - 1 = Verbose (V1) (Default.)
- Bit 4 Reserved
- Bit 5 Tone (T)/Pulse (P)
 - 0 = Tone (T) (Default.)
 - 1 = Pulse (P)
- Bit 6 Reserved
- Bit 7 Originate/Answer
 - 0 = Answer
 - 1 = Originate (Default.)

S16 - Test Mode Bit Mapped Options Status

S16 indicates the test in progress status.

Default: 0

- Bit 0 Local analog loopback
 - 0 = Disabled (Default.)
 - 1 = Enabled (&T1)
- Bits 1-7 Not used.

S19 - Reserved

S19 is supported for backwards compatibility only. No value can be written. Responds with default value.

Range: None

Default: 0

S20 - Reserved

S20 is supported for backwards compatibility only. No value can be written. Responds with default value.

Range: None

Default: 0

S21 - V.24/General Bit Mapped Options Status

S21 indicates the status of command options.

Default:

- 52 (34h) (00110100b)
- Bits 0 - 1 Reserved (0)
- Bit 2 CTS behavior (&Rn)
 - 0 = CTS tracks RTS (&R0)
 - 1 = CTS always on (&R1) (Default.)
- Bits 3-4 DTR behavior (&Dn)
 - 0 = &D0 selected
 - 1 = &D1 selected
 - 2 = &D2 selected (Default.)
 - 3 = &D3 selected
- Bit 5 RLSD (DCD) behavior (&Cn)
 - 0 = &C0 selected
 - 1 = &C1 selected (Default.)
- Bit 6 DSR behavior (&Sn)
 - 0 = &S0 selected (Default.)
 - 1 = &S1 selected
- Bit 7 Long space disconnect (Yn)
 - 0 = Y0 (Default.)
 - 1 = Y1

S22 - Speaker/Results Bit Mapped Options Status

S22 indicates the status of command options.

Default: 117 (75h) (01110101b)

- Bits 0-1 Speaker volume (Ln)
 - 0 = Off (L0)
 - 1 = Low (L1) (Default.)
 - 2 = Medium (L2)
 - 3 = High (L3)
- Bits 2-3 Speaker control (Mn)
 - 0 = Disabled (M0)
 - 1 = Off on carrier (M1) (Default.)
 - 2 = Always on (M2)
 - 3 = On during handshake (M3)
- Bits 4-6 Limit result codes (Xn)
 - 0 = X0
 - 4 = X1
 - 5 = X2
 - 6 = X3
 - 7 = X4 (Default.)
- Bit 7 Reserved

S23 - General Bit Mapped Options Status

S23 indicates the status of command options.

Default: 0

- Bits 0-6 Not used
- Bits 6-7 Guard tone (&Gn)
 - 0 = None (&G0) (Default.)
 - 1 = None (&G1)
 - 2 = 1800 Hz (&G2)

S24 - Sleep Inactivity Timer

S24 sets the length of time, in seconds, that the modem will operate in normal mode with no detected telephone line or DTE line activity before entering low-power sleep mode.

The timer is reset upon any DTE line or telephone line activity. If the S24 value is zero, neither DTE line nor telephone inactivity will cause the modem to enter the sleep mode.

Range: 0-255 seconds

Default: 0

S25 - Delay To DTR Off

S25 sets the length of time that the modem will ignore DTR for taking the action specified by &Dn. Its units are seconds for synchronous modes and one hundredths of a second for other modes.

Range: 0-255 (1 second for synchronous modes 1; 0.01 second otherwise)

Default: 5

S26 - RTS to CTS Delay

S26 sets the time delay, in hundredths of a second, before the modem turns CTS ON after detecting an OFF-to-ON transition on RTS when &R0 is commanded. Pertains to synchronous operation only.

Range: 0-255 hundredths of a second

Default: 1

S27 - Bit Mapped Options Status

S27 indicates the status of command options.

Default: 73 (49h) (01001001b)
 Bits 0,1,3 Synchronous/asynchronous selection (&Mn/&Qn)
31 0
 0 0 0 = &M0 or &Q0
 0 0 1 = &M1 or &Q1
 0 1 0 = &M2 or &Q2
 0 1 1 = &M3 or &Q3
 1 0 0 = Reserved
 1 0 1 = &Q5 (Default.)
 1 1 0 = &Q6
 Bit 2 Leased line control (&Ln)
 0 = Dial up line (&L0) (Default.)
 Bits 4 - 5 Internal clock select (&Xn)
 0 = Internal clock (&X0) (Default.)
 1 = External clock (&X1)
 2 = Slave clock (&X2)
 Bit 6 CCITT/Bell mode select (Bn)
 0 = CCITT mode (B0)
 1 = Bell mode (B1) (Default.)
 Bit 7 – Reserved

S28 - Bit Mapped Options Status

S28 indicates bit mapped options status.

Default: 0
 Bits 0 - 1 Reserved
 Bit 2 Reserved (always 0).
 Bits 3 - 4 Pulse dialing (&Pn)
 0 = 39%-61% make/break ratio at 10 pulses per second (&P0) (Default.)
 1 = 33%-67% make/break ratio at 10 pulses per second (&P1)
 2 = 39%-61% make/break ratio at 20 pulses per second (&P2)
 3 = 33%-67% make/break ratio at 20 pulses per second (&P3)
 Bit 5-7 Reserved

S29 - Flash Dial Modifier Time

S29 sets the length of time, in units of 10 ms, that the modem will go on-hook when it encounters the flash (!) dial modifier in the dial string. S29 is a country dependent parameter. The S29 value cannot be changed using S29=XX.

Range: 0-255 10 ms intervals

Default: 70 (700 ms) for U.S.

S30 - Disconnect Inactivity Timer

S30 sets the length of time, in tens of seconds, that the modem will stay online before disconnecting when no data is sent or received. In error-correction mode, any data transmitted or received will reset the timer. In other modes, any data transmitted will reset the timer. The timer is inoperative in synchronous mode.

Range: 0-255 tens of seconds (0-2550 seconds)

Default: 0 (disabled)

S31 - Bit Mapped Options Status

S31 indicates bit mapped options status.

Default: 192 (C0h) (11000000b)

- Bit 0 Single line connect message enable/disable (\Vn)
 - 0 = Messages controlled by S95, Wn and Vn (\V0) (Default.)
 - 1 = Single line connect message (\V1)
- Bit 1 Reserved (0)
- Bits 2-3 Error correction progress messages (Wn)
 - 0 = DTE speed only (W0) (Default.)
 - 1 = Full reporting (W1)
 - 2 = DCE (line) speed only (W2)
- Bits 4-5 Caller ID (+VCID)
 - 0 = Caller ID disabled (+VCID=0) (Default.)
 - 1 = Short (formatted) Caller ID enabled (+VCID=1)
 - 2 = Long (unformatted) Caller ID enabled (+VCID=2)
- Bits 6-7 Reserved (Default = 11b)

S36 - LAPM Failure Control

Default: 7 (00000111b)

Bits 0-2 This value indicates what should happen upon a LAPM failure. These fallback options are initiated immediately upon connection if S48=128. If an invalid number is entered, the number is accepted into the register, but S36 will act as if the default value has been entered.

- 0 = Modem disconnects.
- 1 = Modem stays on-line and a Direct mode connection is established.
- 2 = Reserved.
- 3 = Modem stays on-line and a Normal mode connection is established.
- 4 = An MNP connection is attempted and if it fails, the modem disconnects.
- 5 = An MNP connection is attempted and if it fails, a Direct mode connection is established.
- 6 = Reserved.
- 7 = An MNP connection is attempted and if it fails, a Normal mode connection is established. (Default.)

Bits 3-7 Reserved

S38 - Delay Before Forced Hang Up

S38 specifies the delay between the modem's receipt of the H command to disconnect (or ON-to-OFF transition of DTR if the modem is programmed to follow the signal), and the disconnect operation. Applicable to error-correction connection only. This parameter can be used to ensure that data in the modem buffer is sent before the modem disconnects.

1. If S38 is set to a value between 0 and 254, the modem will wait that number of seconds for the remote modem to acknowledge all data in the modem buffer before disconnecting. If time expires before all data is sent, the NO CARRIER result code will be issued to indicate that data has been lost. If all data is transmitted prior to time-out, the response to the H0 command will be OK.
2. If S38 is set to 255, the modem does not time-out and continues to attempt to deliver data in the buffer until the connection is lost or the data is delivered.

Range: 0-255 seconds

Default: 20

S39 - Flow Control Bit Mapped Options Status

Default: 3 (00000011b)

Bits 0-2 Status of command options

- 0 = No flow control
- 3 = RTS/CTS (&K3) (Default.)
- 4 = XON/XOFF (&K4)
- 5 = Transparent XON (&K5)
- 6 = Both methods (&K6)

Bits 3-7 Reserved

S40 - General Bit Mapped Options Status

S40 indicates the status of command options.

Default: 104 (68h) (01101000b)

- Bits 0-1 MNP Extended Services (-Kn)
 - 0 = Disable extended services (-K0) (Default.)
 - 1 = Enable extended services (-K1)
 - 2 = Enable extended services (-K2)
- Bit 2 Reserved
- Bits 3-5 Break Handling (\Kn)
 - 0 = \K0
 - 1 = \K1
 - 2 = \K2
 - 3 = \K3
 - 4 = \K4
 - 5 = \K5 (Default.)
- Bits 6-7 Reserved

S41 - General Bit Mapped Options Status

S41 indicates the status of command options.

Default: 13 (C3h) (00001101b)

- Bits 0 -1 Compression selection (%Cn)
 - 0 = Disabled (%C0)
 - 1 = MNP 5 (%C1)
 - 2 = V.42 bis (%C2)
 - 3 = MNP 5 and V.42 bis (%C3) (Default.)
- Bits 2, 6 Auto retrain and fallback/fall forward (%En)
- Bit 6 Bit 2
 - 0 0 = Retrain and fallback/fall forward disabled (%E0)
 - 0 1 = Retrain enabled (%E1)
 - 1 0 = Fallback/fall forward enabled (%E2) (Default.)
- Bit 3 Reserved
- Bits 4-5 Reserved
- Bit 7 Reserved

S46 - Data Compression Control

S46 controls selection of compression. The following actions are executed for the given values:

Range: 136 or 138

Default: 138

- S46=136 Execute error correction protocol with no compression.
- S46=138 Execute error correction protocol with compression. (Default.)

S48 - V.42 Negotiation Control

The V.42 negotiation process determines the capabilities of the remote modem.

However, when the capabilities of the remote modem are known and negotiation is unnecessary, this process can be bypassed if so desired.

Range: 0, 7, or 128 If an invalid number is entered, it is accepted into the S-Parameter, but S48 will act as if 128 has been entered.

Default: 7

- S48=0 Disable negotiation; bypass the detection and negotiation phases; and proceed with LAPM.
- S48=7 Enable negotiation. (Default.)
- S48=128 Disable negotiation; bypass the detection and negotiation phases; and proceed at once with the fallback action specified in S36. Can be used to force MNP.

S86 - Call Failure Reason Code

When the modem issues a NO CARRIER result code, a value is written to S86 Register to help determine the reason for the failed connection. S86 records the first event that contributes to a NO CARRIER message. The code definitions are:

Range: 0-26

Default: 21

- S86=0 Normal hangup, no error occurred.
- S86=1 Reserved.
- S86=2 Reserved.
- S86=3 Call Waiting caused disconnect.
- S86=4 Physical carrier loss.
- S86=5 No error correction at the other end.
- S86=6 No response to feature negotiation.
- S86=7 This modem is async only; the other modem is sync only.
- S86=8 No framing technique in common.
- S86=9 No protocol in common.
- S86=10 Bad response to feature negotiation.
- S86=11 No sync information from the remote modem.
- S86=12 Normal hangup initiated by the remote modem.
- S86=13 Retransmission limit reached.
- S86=14 Protocol violation occurred.
- S86=15 Lost DTR.
- S86=16 Received GSTN clear-down.
- S86=17 Inactivity timeout.
- S86=18 Speed not supported.
- S86=19 Long space disconnect.
- S86=20 Key abort disconnect.
- S86=21 Clears previous disconnect reason.
- S86=22 No connection established.
- S86=23 Disconnect after three retrains.
- S86=24 Call Waiting tone detected.
- S86=25 Extension pickup detected.
- S86=26 Remote hangup detected.

S95 - Extended Result Codes Control

A bit set to a 1 in this parameter, in conjunction with the W command, will enable the corresponding extended result code (see Table 3-16).

The +MR, +ER, and +DR settings also control S95 bits 2, 3, and 5, respectively. The more recent settings of +MR, +ER, and +DR, or host writing of S95 bits 2, 3, and 5, along with the W command setting, determine the corresponding actual result code reporting (see +MR, +ER, DR, and W commands).

Default: 0

- Bit 0 CONNECT result code indicates DCE speed instead of DTE speed.
- Bit 1 Append/ARQ to CONNECT XXXX result code in error-correction mode (XXXX = rate).
- Bit 2 Enable +MCR: XXXX result code (XXXX = modulation) and +MRR: XXXX result code (XXXX = rate). (Also, see +MR.)
- Bit 3 Enable +ER: XXXX result code (XXXX = protocol identifier).
- Bit 4 Reserved.
- Bit 5 Enable +DR: XXXX result code (XXXX = compression type).
- Bits 6-7 Reserved.

S210 – V.34 Symbol Rates

The bits in this parameter control V.34 symbols rates and enables/disables V.34 asymmetric rates. This parameter is used for diagnostic purpose only.

Default: 13 (0Dh) (00001101b)

Bits 0-2 Selects the range of allowed V.34 symbol rates.

2 1 0 Symbol Rates (baud)

- 0 0 0 = 2400 only
- 0 0 1 = 2400 only (no 2734)
- 0 1 0 = 2400, 2800
- 0 1 1 = 2400, 2800, 3000
- 1 0 0 = 2400, 2800, 3000, 3200
- 1 0 1 = 2400, 2800, 3000, 3200, 3429 (Default.)

Bit 3 Enable/disable V.34 asymmetric rates.

- 0 = Disable asymmetric rates
- 1 = Enable asymmetric rates (Default.)

Bits 4-7 Reserved.

Examples:

- S210=13 Enable asymmetric rates with all symbol rates available (Default.).
- S210=5 Disable asymmetric rates with all symbol rates available.
- S210=8 Enable asymmetric rates with only 2400 baud available.
- S210=11 Enable asymmetric rates with 2400 to 3000 baud available.

Result Codes

The modem responds to commands from the DTE and to activity on the line by signaling to the DTE in the form of result codes. The result codes that the modem can send are described in Table 3-16.

Two forms of each result code are available: long-form, an English-like "verbose" response, and short-form, a data-like numeric response (included in parentheses following the long-form). The long-form code is preceded and terminated by the sequence < CR> < LF>. The short-form is terminated by < CR>, only with no preceding sequence.

If result messages are suppressed, nothing is returned to the DTE. The long-form results codes can be modified by the OEM through the .INF file..

Table 3-16. Result Code Definitions

Code	Message	Meaning
+F4	+FCERROR	High speed fax data (V.27, V.29, V.33, or V.17) is expected but a V.21 signal is received.
0	OK	A command line has been executed.
1	CONNECT	For X command values specifying no speed reporting, the modem has connected to the line and either the line speed is 300 bps and line speed is enabled, or the DTE speed is 300 bps and DTE speed reporting is enabled.
2	RING	An incoming ring signal is detected on the line. What qualifies as a ring signal is determined by country-dependent parameters. When cellular interface is selected, RING indicates that the cellular phone is receiving an receiving an incoming call.
3	NO CARRIER	Sent when attempting to establish a call if: <ol style="list-style-type: none"> 1. Ringback is detected and later ceases but no carrier is detected within the period of time determined by register S7, or 2. No ringback is detected within the period of time determined by register S7. Also sent when the modem auto-disconnects due to loss of carrier. For X0, sent for the following conditions: <ol style="list-style-type: none"> 1. If busy tone detection is enforced, busy or circuit busy has been detected. 2. If dial tone detection is enforced or selected, dial tone has not been detected.
4	ERROR	Sent during an attempt to execute a command line if any of the following conditions occur: <ol style="list-style-type: none"> 1. The command line contains a syntax error. 2. The modem cannot execute a command contained in the command line, i.e., the command does not exist or is not supported. 3. A command parameter within the command line is outside the permitted range. For X0, X1, X2, and X3, this message is sent instead of DELAYED and BLACKLISTED.
5	CONNECT 1200	The modem has connected to the line and either the line speed is 1200 bps and DCE speed reporting is enabled, or the DTE speed is 1200 bps and DTE speed reporting is enabled.
6	NO DIAL TONE	For X2 and X4, the modem has been instructed to wait for dial tone during dialing but none is received. When cellular phone interface is selected, indicates that cellular service is not currently available.
7	BUSY	For X3 and X4, if busy tone detection is enforced, the busy (engaged) signal is detected on the line when the modem is attempting to originate a call.
8	NO ANSWER	The modem is attempting to originate a call if a continuous ringback signal is detected on the line until the expiration of the timer S7
9	CONNECT 600	The modem has connected to the line, the DTE speed is 600 bps, and DTE speed reporting is enabled.
10	CONNECT 2400	The modem has connected to the line and either the line speed is 2400 bps and DCE speed reporting is enabled, or the DTE speed is 2400 bps and DTE speed reporting is enabled.
11	CONNECT 4800	The modem has connected to the line and either the line speed is 4800 bps and DCE speed reporting is enabled, or the DTE speed is 4800 bps and DTE speed reporting is enabled.

12	CONNECT 9600	The modem has connected to the line and either the line speed is 9600 bps and DCE speed reporting is enabled, or the DTE speed is 9600 bps and DTE speed reporting is enabled.
13	CONNECT 7200	The modem has connected to the line at 7200 bps and DCE speed reporting is enabled.
14	CONNECT 12000	The modem has connected to the line at 12000 bps and DCE speed reporting is enabled.
15	CONNECT 14400	The modem has connected to the line at 14400 bps and DCE speed reporting is enabled.
16	CONNECT 19200	The modem has connected to the line and either the line speed is 19200 bps and DCE speed reporting is enabled, or the DTE speed is 19200 bps and DTE speed reporting is enabled.
17	CONNECT 38400	The modem has connected to the line, the DTE speed is 38400 bps, and DTE speed reporting is enabled.
18	CONNECT 57600	The modem has connected to the line, the DTE speed is 57600 bps, and DTE speed reporting is enabled.
19	CONNECT 115200	The modem has connected to the line, the DTE speed is 115200 bps, and DTE speed reporting is enabled.
22	CONNECT 75TX/1200RX	The modem has established a V.23 originate connection and line speed reporting is enabled.
23	CONNECT 1200TX/75RX	The modem has established a V.23 answer connection and line speed reporting is enabled.
24	DELAYED	For X4, sent when a call fails to connect and the number dialed is considered 'delayed' due to country blacklisting requirements.
32	BLACKLISTED	For X4, sent when a call fails to connect and the number dialed is considered 'blacklisted'.
33	FAX	A fax modem connection is established in a facsimile mode.
35	DATA	A data modem connection is established in a facsimile mode.
40	+MRR: 300	The modem has connected to the line at 300 bps and carrier reporting is enabled. (See S95 and Xn.)
44	+MRR: 1200/75	The V.23 backward channel carrier is detected and carrier reporting is enabled. (See S95 and Xn.)
45	+MRR: 75/1200	The V.23 forward channel carrier is detected and carrier reporting is enabled. (See S95 and Xn.)
46	+MRR: 1200	The modem has connected to the line at 1200 bps and carrier reporting is enabled. (See S95 and Xn.)
47	+MRR: 2400	The modem has connected to the line at 2400 bps and carrier reporting is enabled. (See S95 and Xn.)
48	+MRR: 4800	The modem has connected to the line at 4800 bps and carrier reporting is enabled. (See S95 and Xn.)
49	+MRR: 7200	The modem has connected to the line at 7200 bps and carrier reporting is enabled. (See S95 and Xn.)
50	+MRR: 9600	The modem has connected to the line at 9600 bps and carrier reporting is enabled. (See S95 and Xn.)
51	+MRR: 12000	The modem has connected to the line at 12000 bps and carrier reporting is enabled. (See S95 and Xn.)
52	+MRR: 14400	The modem has connected to the line at 14400 bps and carrier reporting is enabled. (See S95 and Xn.)
53	+MRR: 16800	The modem has connected to the line at 16800 bps and carrier reporting is enabled. (See S95 and Xn.)
54	+MRR: 19200	The modem has connected to the line at 19200 bps and carrier reporting is enabled. (See S95 and Xn.)
55	+MRR: 21600	The modem has connected to the line at 21600 bps and carrier reporting is enabled. (See S95 and Xn.)
56	+MRR: 24000	The modem has connected to the line at 24000 bps and carrier reporting is enabled. (See S95 and Xn.)
57	+MRR: 26400	The modem has connected to the line at 26400 bps and carrier reporting is enabled. (See S95 and Xn.)
58	+MRR: 28800	The modem has connected to the line at 28800 bps and carrier reporting is enabled. (See S95 and Xn.)
59	CONNECT 16800	The modem has connected to the line, the DTE speed is 16800 bps and DTE speed reporting is enabled.
61	CONNECT 21600	The modem has connected to the line, the DTE speed is 21600 bps and DTE speed reporting is enabled.

62	CONNECT 24000	The modem has connected to the line, the DTE speed is 24000 bps and DTE speed reporting is enabled.
63	CONNECT 26400	The modem has connected to the line, the DTE speed is 26400 bps and DTE speed reporting is enabled.
64	CONNECT 28800	The modem has connected to the line and either the line speed is 28800 bps and DCE speed reporting is enabled, or the DTE speed is 28800 bps and DTE speed reporting is enabled.
66	+DR: ALT	The modem has connected to the line in MNP Class 5 and +DR: message reporting is enabled. (See S95, Wn, and Xn.)
67	+DR: V.42B	The modem has connected to the line in V.42 bis and +DR: message reporting is enabled. (See S95, Wn, and Xn.)
69	+DR: NONE	The modem has connected to the line without data compression and +DR: message reporting is enabled. (See S95, Wn, and Xn.)
70	+ER: NONE	The modem has connected to the line without any form of error correction and the +ER: message reporting has been enabled. (See S95, Wn, and Xn.)
77	+ER: LAPM	The modem has connected to the line in V.42 LAPM error correction mode and +ER: message reporting has been enabled. (See S95, Wn, and Xn.)
78	+MRR: 31200	The modem has connected to the line at 31200 bps and carrier reporting is enabled. (See S95 and Xn.)
79	+MRR: 33600	The modem has connected to the line at 33600 bps and carrier reporting is enabled. (See S95 and Xn.)
80	+ER: ALT	Sent when the modem has connected in the MNP mode of error correction, and +ER: message reporting has been enabled. (See S95, Wn, and Xn.)
81	+ER: ALT-CELLULAR	The modem has connected in the MNP 10 mode and cellular power level adjustment is enabled ("M1 or M2").(See S95, Wn, and Xn.)
83	LINE-IN-USE	The modem attempted to go off-hook when an extension was already occupying the line.
84	CONNECT 33600	The modem has connected to the line, the DTE speed is 33600 bps and the DTE speed reporting is enabled.
91	CONNECT 31200	The modem has connected to the line DTE speed is 31200 bps and the modem is to report the DTE speed upon connecting.
134	+MCR: B103	The modem has connected to the line with Bell 103 modulation and modulation reporting is enabled. (See +MR, S95 and Xn.)
135	+MCR: B212	The modem has connected to the line with Bell 212 modulation and modulation reporting is enabled. (See +MR, S95 and Xn.)
136	+MCR: V21	The modem has connected to the line with ITU-T V.21 modulation and modulation reporting is enabled. (See +MR, S95 and Xn.)
137	+MCR: V22	The modem has connected to the line with ITU-T V.22 modulation and modulation reporting is enabled. (See +MR, S95 and Xn.)
138	+MCR: V22B	The modem has connected to the line with ITU-T V.22 bis modulation and modulation reporting is enabled. (See +MR, S95 and Xn.)
139	+MCR: V23	The modem has connected to the line with ITU-T V.23 modulation and modulation reporting is enabled. (See +MR, S95 and Xn.)
140	+MCR: V32	The modem has connected to the line with ITU-T V.32 modulation and modulation reporting is enabled. (See +MR, S95 and Xn.)
141	+MCR: V32B	The modem has connected to the line with ITU-T V.32 bis modulation and modulation reporting is enabled. (See +MR, S95 and Xn.)
142	+MCR: V34	The modem has connected to the line with ITU-T V.34 modulation and modulation reporting is enabled. (See +MR, S95 and Xn.)
144	+MCR: K56	The modem has connected to the line with K56flex modulation and modulation reporting is enabled. (See +MR, S95 and Xn.)
145	+MCR: V90	The modem has connected to the line with ITU-T V.90 modulation and modulation reporting is enabled. (See +MR, S95 and Xn.)
150	+MRR: 32000	The modem has connected to the line at 32000 bps and carrier reporting is enabled. (See S95 and Xn.)
151	+MRR: 34000	The modem has connected to the line at 34000 bps and carrier reporting is enabled. (See S95 and Xn.)
152	+MRR: 36000	The modem has connected to the line at 36000 bps and carrier reporting is enabled. (See S95 and Xn.)
153	+MRR: 38000	The modem has connected to the line at 38000 bps and carrier reporting is enabled. (See S95 and Xn.)
154	+MRR: 40000	The modem has connected to the line at 40000 bps and carrier reporting is enabled. (See S95 and Xn.)
155	+MRR: 42000	The modem has connected to the line at 42000 bps and carrier reporting is

		enabled. (See S95 and Xn.)
156	+MRR: 44000	The modem has connected to the line at 44000 bps and carrier reporting is enabled. (See S95 and Xn.)
157	+MRR: 46000	The modem has connected to the line at 46000 bps and carrier reporting is enabled. (See S95 and Xn.)
158	+MRR: 48000	The modem has connected to the line at 48000 bps and carrier reporting is enabled. (See S95 and Xn.)
159	+MRR: 50000	The modem has connected to the line at 50000 bps and carrier reporting is enabled. (See S95 and Xn.)
160	+MRR: 52000	The modem has connected to the line at 52000 bps and carrier reporting is enabled. (See S95 and Xn.)
161	+MRR: 54000	The modem has connected to the line at 54000 bps and carrier reporting is enabled. (See S95 and Xn.)
162	+MRR: 56000	The modem has connected to the line at 56000 bps and carrier reporting is enabled. (See S95 and Xn.)
165	CONNECT 32000	The modem has connected to the line at 32000 bps and DCE speed reporting is enabled.
166	CONNECT 34000	The modem has connected to the line at 34000 bps and DCE speed reporting is enabled.
167	CONNECT 36000	The modem has connected to the line at 36000 bps and DCE speed reporting is enabled.
168	CONNECT 38000	The modem has connected to the line at 38000 bps and DCE speed reporting is enabled.
169	CONNECT 40000	The modem has connected to the line at 40000 bps and DCE speed reporting is enabled.
170	CONNECT 42000	The modem has connected to the line at 42000 bps and DCE speed reporting is enabled.
171	CONNECT 44000	The modem has connected to the line at 44000 bps and DCE speed reporting is enabled.
172	CONNECT 46000	The modem has connected to the line at 46000 bps and DCE speed reporting is enabled.
173	CONNECT 48000	The modem has connected to the line at 48000 bps and DCE speed reporting is enabled.
174	CONNECT 50000	The modem has connected to the line at 50000 bps and DCE speed reporting is enabled.
175	CONNECT 52000	The modem has connected to the line at 52000 bps and DCE speed reporting is enabled.
176	CONNECT 54000	The modem has connected to the line at 54000 bps and DCE speed reporting is enabled.
177	CONNECT 56000	The modem has connected to the line at 56000 bps and DCE speed reporting is enabled.
178	CONNECT 230400	The modem has connected to the line, the DTE speed is 230400 bps, and DTE speed reporting is enabled.
180	CONNECT 28000	The modem has connected to the line at 28000 bps and DCE SPEED reporting is enabled.
181	CONNECT 29333	The modem has connected to the line at 29333 bps and DCE SPEED reporting is enabled.
182	CONNECT 30667	The modem has connected to the line at 30667 bps and DCE SPEED reporting is enabled.
183	CONNECT 33333	The modem has connected to the line at 33333 bps and DCE SPEED reporting is enabled.
184	CONNECT 34667	The modem has connected to the line at 34667 bps and DCE SPEED reporting is enabled.
185	CONNECT 37333	The modem has connected to the line at 37333 bps and DCE SPEED reporting is enabled.
186	CONNECT 38667	The modem has connected to the line at 38667 bps and DCE SPEED reporting is enabled.
187	CONNECT 41333	The modem has connected to the line at 41333 bps and DCE SPEED reporting is enabled.
188	CONNECT 42667	The modem has connected to the line at 42667 bps and DCE SPEED reporting is enabled.
189	CONNECT 45333	The modem has connected to the line at 45333 bps and DCE SPEED reporting is enabled.
190	CONNECT	The modem has connected to the line at 46667 bps and DCE SPEED reporting

	46667	is enabled.
191	CONNECT 49333	The modem has connected to the line at 49333 bps and DCE SPEED reporting is enabled.
192	CONNECT 50667	The modem has connected to the line at 50667 bps and DCE SPEED reporting is enabled.
193	CONNECT 53333	The modem has connected to the line at 53333 bps and DCE SPEED reporting is enabled.
194	CONNECT 54667	The modem has connected to the line at 54667 bps and DCE SPEED reporting is enabled.
195	+MRR: 28000	The modem has connected to the line at 28000 bps and carrier reporting is enabled. (See S95 and Xn.)
196	+MRR: 29333	The modem has connected to the line at 29333 bps and carrier reporting is enabled. (See S95 and Xn.)
197	+MRR: 30667	The modem has connected to the line at 30667 bps and carrier reporting is enabled. (See S95 and Xn.)
198	+MRR: 33333	The modem has connected to the line at 33333 bps and carrier reporting is enabled. (See S95 and Xn.)
199	+MRR: 34667	The modem has connected to the line at 34667 bps and carrier reporting is enabled. (See S95 and Xn.)
200	+MRR: 37333	The modem has connected to the line at 37333 bps and carrier reporting is enabled. (See S95 and Xn.)
201	+MRR: 38667	The modem has connected to the line at 38667 bps and carrier reporting is enabled. (See S95 and Xn.)
202	+MRR: 41333	The modem has connected to the line at 41333 bps and carrier reporting is enabled. (See S95 and Xn.)
203	+MRR: 42667	The modem has connected to the line at 42667 bps and carrier reporting is enabled. (See S95 and Xn.)
204	+MRR: 45333	The modem has connected to the line at 45333 bps and carrier reporting is enabled. (See S95 and Xn.)
205	+MRR: 46667	The modem has connected to the line at 46667 bps and carrier reporting is enabled. (See S95 and Xn.)
206	+MRR: 49333	The modem has connected to the line at 49333 bps and carrier reporting is enabled. (See S95 and Xn.)
207	+MRR: 50667	The modem has connected to the line at 50667 bps and carrier reporting is enabled. (See S95 and Xn.)
208	+MRR: 53333	The modem has connected to the line at 53333 bps and carrier reporting is enabled. (See S95 and Xn.)
209	+MRR: 54667	The modem has connected to the line at 54667 bps and carrier reporting is enabled. (See S95 and Xn.)
Notes:		
<ol style="list-style-type: none"> 1. See Vn for result code selection, i.e., short form (result code) or verbose/extended (result message). 2. See Wn for extended connect message control. 3. See S95 for extended result code enabling options (which override some Wn commands). 4. See Xn for extended result code subset enabling options. 5. See \Vn for single line connect message enable options. 6. See +MR for modulation reporting control. 		

Chapter 4 – Fax Class 1 and Class 1.0 Commands

Fax I/O Processing

The fax I/O interface supports asynchronous serial and parallel interfaces. The character format is 8 bits data, no parity, and 1 stop bit. Start and stop elements are removed from the transmit data and added to the receive data. Both transmit and receive data are buffered. Flow control using XON/XOFF or RTS/CTS is provided.

Unique control character strings are identified, filtered, or reinserted into the I/O data stream. These control characters and their resultant action are described below.

DTE-to-Modem Transmit Data Stream

Characters Detected

<DLE><data>
<DLE><ETX>
<DLE><DLE>

Action Taken

Delete <DLE><data> characters.
Recognize as a string terminator and take appropriate action.
Replace with single <DLE> character.

Modem-to-DTE Receive Data Stream

Characters Detected

<DLE>

Action Taken

Insert extra <DLE> ahead of <DLE>.

The modem also identifies the end of a frame by inserting <DLE><ETX> into the data stream after the FCS bytes.

Fax Mode Selection

Fax Class 1 and Fax Class 1.0 commands are identified in Table 4-1. Fax Class 1.0 includes all Fax Class 1 commands

Table 4-1. Fax Class 1 and Fax Class 1.0 Commands

Command/Parameter	Function	Applicable in Fax Class 1	Applicable in Fax Class 1.0
+FCLASS=<class>	Select, read or test service class	X	X
+FAA=<value>	Auto answer enable	-	X
+FAE=<value>	Auto answer enable	X	X
+FTS=<time>	Stop transmission and pause	X	X
+FRS=<time>	Wait for silence	X	X
+FTM=<mod>	Transmit data with <mod> carrier	X	X
+FRM=<mod>	Receive data with <mod> carrier	X	X
+FTH=<mod>	Transmit HDLC data with <mod> carrier	X	X
+FRH=<mod>	Receive HDLC data with <mod> carrier	X	X
+FAR=<off/on>	Adaptive reception control	-	X
+FCL=<time>	Carrier loss timeout	-	X
+FDD=<value>	Double escape character replacement control	-	X
+FIT=<time>, <action>	DTE inactivity timeout	-	X
+FPR=<rate>	Fixed DTE Rate	-	X
+FMI?	Report manufacturer ID	-	X
+FMM?	Report model ID	-	X
+FMR?	Report revision ID	-	X
+FLO	Flow Control	-	X
&K	Local DTE-modem flow control (see Call Control Section)	X	X
A	Answer	X	X
D<string>	Dial	X	X
H	Hangup (see Call Control Section)	X	X

X = Applicable; - = Not applicable.

Fax Origination

Origination of fax calls is made using the ATD command. Upon completion of the dial function, a calling tone at 1100 Hz is transmitted, with a cadence of 0.5 seconds on and 3 seconds off. The modem automatically enters mode +FRH=3 and sends the CONNECT message to the DTE when FSK flags are detected from the remote.

Fax Answering

Answering of fax calls is identical to answering of data calls with the exception that the modem enters the fax handshaking mode instead of the data handshaking mode after going off-hook. If +FAE=0, the modem, after sending answer tone, automatically enters fax mode (+FTH=3), sends the CONNECT message to the DTE, and starts sending FSK flags. If +FAE=1, the modem determines whether the caller is a data modem or fax modem and sends the DATA or FAX result code, respectively, to the DTE.

Fax Control Transmission

Fax control transmission is initiated by the +FTH=<mod> command. After this command is issued, the modem generates the CONNECT message and transmits carrier in the modulation scheme specified by the parameter n. The modem then transmits HDLC flags for a minimum of 1 second. The modem continues to transmit the HDLC flags until it receives a character from the DTE.

When characters are received from the DTE, the modem adds start and end flags, performs zero-bit insertion, generates FCS, and deletes <DLE><chr> character pairs before transmitting the characters to the remote fax machine. Each <DLE><DLE> sequence is transmitted as a single <DLE>. <DLE><ETX> is considered as the end of frame marker and is not transmitted. All data received from the DTE after <DLE><ETX> is ignored by the modem until the modem generates either the CONNECT, OK, or ERROR result code.

If no more data is in the transmit buffer and the final bit was a 1 (bit 4 of the second byte received from the DTE), the modem generates the OK result code and returns to the command mode. If the final bit was a 0, the modem generates the CONNECT message and waits for further data from the DTE while transmitting HDLC flags. If no more data is received before 5 seconds elapse, the modem drops carrier, goes on-hook, and generates the ERROR result code.

Fax Control Reception

Fax control reception is initiated using the AT+FRH=<mod> command. After this command is issued, the modem looks for carrier in the modulation scheme specified by the parameter n. If no carrier is detected before the period of time specified by register S7 expires, the modem generates the NO CARRIER message and returns to command mode.

If a carrier is detected that is not the one specified by the parameter n, the modem generates the +FCERROR message and returns to the command mode. If the specified carrier is detected, the modem generates the CONNECT message and enters the HDLC receive mode.

In HDLC receive mode, the modem receives HDLC frames from the remote fax machine, strips the flags, performs zero-bit deletion, performs error checking, and handles <DLE><chr> character pairs before passing the data to the DTE. The modem prefixes each <DLE> character with another <DLE> character before sending it to the DTE. After the last byte in the frame, the modem sends <DLE><ETX> to the DTE marking the end of the frame. The modem then generates either the OK message if no errors were detected or the ERROR message if errors were detected (FCS is incorrect), and returns to command mode.

While in command mode, the modem continues to receive data in the selected modulation scheme, and sends the data after sending the CONNECT message to the DTE when the DTE reissues the +FRH command with the same parameter. If the DTE issues the +FRH command with a different parameter, the modem clears all buffers and proceeds as described previously.

If carrier is lost while in command mode and the DTE reissues the +FRH command with the same parameter, and there is no data in the buffer, the modem sends the ERROR result code to the DTE and returns to the command mode. If there is data in the buffer, the modem sends the next frame of buffered data to the DTE, followed by <DLE><ETX>, and either the ERROR result code if errors were detected or the OK result code if no errors were detected. The modem then returns to command mode.

The modem concludes an error is detected if carrier is lost for any period of time during or before the reception of a frame. If carrier is lost for a time period longer than the time specified by the register S10, the modem finishes delivering the data in the receive buffer (if any) to the DTE, sends <DLE><ETX>, generates the ERROR message, and returns to command mode. All subsequent data received from the remote is discarded.

If the modem detects a frame abort sequence (seven consecutive ones with no zero insertion) while it is waiting for a frame beginning flag (it was receiving HDLC flags), it will wait for the HDLC flags again until either carrier is lost or the DTE aborts the process by sending an abort character or by dropping DTR with &D2 in effect. If the frame abort sequence is detected while the modem is receiving a frame it finishes delivering the data in the receive buffer (if any) to the DTE, sends <DLE><ETX>, generates the ERROR message, and returns to command mode. The modem keeps looking for HDLC flags followed by more data from the remote, with the selected modulation scheme.

If the modem detects a receive buffer overflow condition, it concludes that there was an FCS error in that frame. The modem will receive more frames only if a starting flag is detected and there is room in the receive buffer. If a starting flag is detected and there is no room in the buffer, the modem discards all data in that frame.

If the modem receives any character from the DTE after the +FRH command (except flow control characters if software flow control is in effect), or if the modem detects a high-to-low transition of the DTR signal while &D1 is in effect, it sends <DLE><ETX> to the DTE, generates OK result code, and returns to command mode. The receive buffer is cleared and all data received from the remote is discarded. If the modem detects a DTR drop while &D2 is in effect, it goes on-hook, sends <DLE><ETX> to the DTE, generates OK result code, and returns to command mode. If the modem detects a DTR drop while &D3 is in effect, the modem performs a warm reset.

Fax Data Transmission

Fax data transmission is initiated by the AT+FTM=<mod> command. After this command is issued, the modem generates the CONNECT message and transmits carrier in the modulation scheme specified by the parameter n. The modem then transmits constant 1 bits for a minimum of one second and continues to transmit constant 1 bits until it receives a character from the DTE.

When data is received from the DTE, the modem deletes start and stop bits and deletes all <DLE><chr> character pairs before transmitting the data to the remote. Each <DLE><DLE> sequence is transmitted as a single <DLE>. <DLE><ETX> is considered as the end of stream marker, and is not transmitted. All data received from the DTE after the <DLE><ETX> is ignored by the modem until the modem generates either the CONNECT, OK, or ERROR result code.

If no more data is in the transmit buffer, and the last transmitted character was not an ASCII NULL, the modem generates the OK result code and returns to the command mode. If the last character transmitted was an ASCII NULL, the modem generates the CONNECT message to the DTE and waits for further data from the DTE while transmitting NULLs to the remote. If more data is received before five seconds elapse, the modem continues to transmit the data as described in the previous paragraph. If five seconds elapse and no data is received from the DTE, the modem drops carrier, goes on-hook, and generates the ERROR result code.

Fax Data Reception

Fax data reception is initiated using the AT+FRM=<mod> command. After this command is issued, the modem looks for carrier in the modulation scheme specified by the parameter n. If no carrier is detected before the period of time specified by register S7 expires, the modem generates the NO CARRIER message and returns to command mode. If a V.21 carrier is detected when a high speed carrier is expected, the modem generates the +FCERROR message and returns to the command mode. If the specified carrier is detected, the modem generates the CONNECT message and enters the data receive mode.

While in data receive mode, the modem receives data from the remote, adds start and stop bits, and handles <DLE><chr> character pairs before passing the data to the DTE. The modem prefixes each <DLE> character with another <DLE> character before sending it to the DTE.

If the modem detects a receive buffer overflow condition, it stops receiving from the remote until there is room in the receive buffer. The modem informs the DTE of the buffer overflow after it sends to the DTE the last character that was stored in the buffer before the overflow occurred.

If the modem receives any character from the DTE after the +FRM command (except flow control characters if software flow control is in effect), or if the modem detects a high-to-low transition of the DTR signal while &D1 is in effect, it sends <DLE><ETX> to the DTE, generates the OK result code, and returns to command mode. The receive buffer is cleared and all data received from the remote is discarded. If loss of DTR is detected while &D2 is in effect, the modem goes on-hook, sends <DLE><ETX> followed by OK result code to the DTE, and returns to command mode. If the modem detects a DTR drop while &D3 is in effect, the modem performs a warm reset.

Commands and Parameters

Mode Entry Commands

+FCLASS=1 Select Facsimile Class 1 Mode

+FCLASS=1 selects the Fax Class 1 Mode. The Fax Class 1 Mode commands and responses described in this section are applicable when command +FCLASS=1 as shown in Table 4-1.

+FCLASS=1.0 - Select Facsimile Class 1.0 Mode

+FCLASS=1.0 selects the Fax Class 1.0. The Fax Class 1.0 Mode commands and responses described in this section are applicable when command +FCLASS=1.0 as shown in Table 4-1.

Mode Commands

Command: +FAA Auto Answer Enable

Description: This command enables or disables fax adaptive answer. This command operates identically to the +FAE command.

Syntax: +FAA=<value>

Defined Values: <value> Decimal number corresponding to the selected option.
 0 Disable data /fax auto answer mode. (Default.)
 1 Enable data /fax auto answer mode. The modem determines the calling type and issues DATA result code (13) if the caller is a data modem or issues FAX result code (15) if the caller is a fax modem.

Command: +FAE Auto Answer Enable

Description: This command enables or disables fax adaptive answer. This command operates identically to the +FAA command.

Syntax: +FAE=<value>

Defined Values: <value> Decimal number corresponding to the selected option.
 0 Disable data /fax auto answer mode. (Default.)
 1 Enable data /fax auto answer mode. The modem determines the calling type and issues DATA result code (13) if the caller is a data modem or issues FAX result code (15) if the caller is a fax modem.

After a data (not fax) connection is achieved (indicated by the DATA result code), the DTE must issue an ATO command to cause the modem to go on-line.

Command: +FTS Transmit Silence

Description: This command causes the modem to terminate a transmission and wait for <time> 10-ms intervals before responding with the OK result code.

Syntax: +FTS=<time>

Defined Values: <time> Decimal number from 0 (default) to 255 which specifies the length of time in 10-ms intervals to delay before responding with the OK result code after terminating the session.

Result Codes: OK Reported when transmission has been terminated for the specified amount of time. ERROR <value> is invalid or this command is issued while the modem is on-hook.

Reporting Supported Range of Parameter Values ;
 Command: +FTS=?
 Response: +FTS: <time> range
 Example: +FTS: 0-255.

Command: +FRS Receive Silence

Description: This command causes the modem to listen and report an OK result code when silence has been detected on the line for the specified period of time. This command will terminate when the required period of silence is detected or when the DTE sends the modem another character other than XON or XOFF, which is discarded. In either event, the OK result code is returned.
 This command is aborted if any character is received from the DTE after receipt of the command but before the time delay elapses. In this case, the modem discards the aborting character and issues an OK result code.

Syntax: +FRS =<time>

Defined Values: <time> Decimal number from 0 (default) to 255 which specifies the length of time in 10-ms intervals to delay before responding with the OK result code after detecting silence on the line.

Result Codes: OK Reported when silence has been present on the line for the specified amount of time or when the DTE sends the modem a character other than XON or XOFF.
 ERROR <value> is invalid or this command is issued while the modem is on-hook.

Reporting Supported Range of Parameter Values:
 Command: +FRS=?
 Response: +FRS: <time> range
 Example: +FRS: 0-255

Command: +FTM Transmit Facsimile

Description: This command causes the modem to transmit data using the modulation defined below. When a valid <mod> value is entered, the modem transmits the proper training sequence in the selected mode, followed by constant 1 bits until data is received from the DTE. The modem also returns the CONNECT result code at the beginning of the training sequence.

Syntax: +FTM=<mod>

Defined Values: <mod> Decimal number corresponding to the selected modulation mode and data rates shown in Table 4-2.

Table 4-2. Fax Class 1 and Fax Class 1.0 Modulation Modes and Rates

<mod>	Modulation	Training	Modulation Mode and Rate
3	V.21		300 bps
24	V.27 ter		2400 bps
48	V.27 ter		4800 bps
72	V.29		7200 bps
73	V.17	long	7200 bps long
74	V.17	short	7200 bps short
96	V.29		9600 bps
97	V.17	long	9600 bps long
98	V.17	short	9600 bps short
121	V.17	long	12000 bps long
122	V.17	short	12000 bps short
145	V.17	long	14400 bps long
146	V.17	short	14400 bps short

Result Codes: CONNECT Reported when the modems begins the training sequence after receipt of a valid <mod> value.
 ERROR If the modem’s transmit buffer becomes empty and the last transmitted character is NUL (00), the modem continues to transmit NULs until the DTE sends more data or five seconds elapses. After five seconds elapse with a empty transmit buffer, the modem will turn off the transmit carrier, return to the command state, and report the ERROR result code.
 OK If the modem’s transmit buffer becomes empty and the last transmitted character is was not NUL, the modem will turn off the transmit carrier, return to the command state, and report the OK result code.

Reporting Current or Selected Values:

Command: +FTM?
 Response: +FTM: <mod>
 Example: +FTM: 98 For V.17 9600 bps.

Reporting Supported Range of Parameter Values:

Command: +FTM=?
 Response: +FTM: (<mod> range)
 Example: +FTM: 3,24,48,72,73,74,96,97,98,121,122,145,146

Command: +FRM Receive Facsimile

Description: This command causes the modem to enter the receiver mode using the modulation defined below.

Syntax: +FRM=<mod>

Defined Values: <mod> Decimal number corresponding to the selected modulation mode and data rates shown in Table 4-2.

Reporting Current or Selected Values:

Command: +FRM?
 Response: +FRM: <mod>
 Example: +FRM: 98 For V.17 9600 bps.

Reporting Supported Range of Parameter Values:

Command: +FRM=?
 Response: +FRM: (<mod> range)
 Example: +FRM: 3,24,48,72,73,74,96,97,98,121,122,145,146

Result Codes:

CONNECT Reported when the selected carrier is detected.
 +FCERROR Reported if another carrier is detected and FAR=0; the modem then returns to the command state.
 NO CARRIER Reported if loss-of-carrier is detected.
 OK Reported if the DTE sends any character to the modem other than XON or XOFF while operating in configured flow control from the DTE; the modem then returns to the command state.

Command: FTH Transmit Data with HDLC Framing

Description: This command causes the modem to transmit data using HDLC protocol and the modulation defined below.

Syntax: +FTH=<mod>

Defined Values: <mod> Decimal number corresponding to the selected modulation mode and data rates shown in Table 4-2.

Result Codes:

CONNECT Reported for either of two conditions:
 1. At the beginning of transmission of the training pattern for the selected modulation.
 2. If the Final Frame bit is 0.
 OK Reported for either of two conditions:
 1. If the Final Frame Bit is 1.
 2. If the DTE sends only <DLE><ETX> (a null frame) while transmitting flags.
 ERROR Reported if five seconds elapse from the time when the modem reported the CONNECT result code without any additional data transmitted from the DTE; the modem then turns off carrier and returns to the command mode.

Reporting Current or Selected Values:

Command: +FTH?
 Response: +FTH: <mod>
 Example: +FTH: 98 For V.17 9600 bps.

Reporting Supported Range of Parameter Values:

Command: +FTH?
 Response: +FTH?
 Example: +FTH: 98 For V.17 9600 bps.

Command:	+FRH	Receive Data with HDLC Framing
Description:		This command causes the modem to receive frames using HDLC protocol and the modulation defined below. An ERROR response code results if this command is issued while the modem is on-hook.
Syntax:		+FRH=<mod>
Defined Values:		<mod> Decimal number corresponding to the selected modulation mode and data rates shown in Table 4-2.
Reporting Current or Selected Values:		Command: +FRH? Response: +FRH: <mod> Example: +FRH: 98 For V.17 9600 bps.
Reporting Supported Range of Parameter Values:		Command: +FRH? Response: +FRH? Example: +FRH: 98 For V.17 9600 bps.
Result Codes:		CONNECT Reported for either of two conditions: <ol style="list-style-type: none"> 1. When the selected carrier is detected with an HDLC flag. 2. If the DTE sends another +FTH=<MOD> command after sending the result code indicating frame reception is complete. +FCERROR Reported if a different carrier is detected and FAR=0. NO CARRIER Reported if loss of carrier is detected. OK Reported for either of two conditions: <ol style="list-style-type: none"> 1. If a frame was received correctly. 2. If the DTE sends any character other than XON or XOFF while the modem is in the configured flow control. ERROR Reported if a frame was received in error.

Service Class 1 Parameters

Command:	+FAR	Adaptive Reception Control
Description:		If Adaptive Reception is enabled, the modem adaptively detects the selected message carrier or V.21 control messages. If the expected carrier is detected, the modem operates as specified in the respective +FRM=<mod or +FRH=<mod commands. If V.21 flag preamble is detected instead, the modem issues a +FRH:3 intermediate result code, and then executes an implied +FRH=3 command.
Write Syntax:		+FAR=<value
Defined Values:		<value> Decimal number corresponding to the selected option. 0 Disable Adaptive Reception. (Default.) 1 Enable Adaptive Reception.
Reporting Current or Selected Values:		Command: +FAR? Response: +FAR: <value Example: +FAR: 0 For the default setting.
Reporting Supported Range of Parameter Values:		Command: +FAR=? Response: +FAR: (<value> range) Example: +FAR: (0,1)

Command:	+FCL	Carrier Loss Timeout
Description:		This parameter allows the DTE to select the modem's loss-of-carrier delay between initial loss-of-carrier and qualified loss-of-carrier, when the modem will give up and exit a receive mode. Intermediate (less than FCL timeout) loss-of-carrier should be indicated by insertion of the SQ-BAD signal quality indicator in the received data stream. In unframed receive modes, if the modem detects RTC as described in Recommendation T.30 prior to initial loss of the high speed carrier, or if the modem detects V.21 carrier after initial loss of high speed carrier, then the modem immediately accepts the loss-of-carrier as qualified, without waiting for the FCL timer to expire. In HDLC receive modes, if the modem detects HDLC abort prior to initial loss of the high speed carrier, or if the modem detects V.21 carrier after initial loss of high speed carrier, then the modem immediately accepts the loss-of-carrier as qualified, without waiting for the FCL timer to expire.
Write Syntax:		+FCL=<time
Defined Values:		<value> Decimal number representing the loss-of-carrier delay time in units of 100 ms. The range is 0 - 255.
Reporting Current or Selected Values:		Command: +FCL? Response: +FCL: <time Example: +FCS: 0 For the default setting.
Reporting Supported Range of Parameter Values:		Command: +FCL=? Response: +FCL: (time range) Example: +FCL: (0-255)
Command:	+FDD	Double Escape Character Replacement
Description:		This parameter conditions the use of the ~DLE~SUB pair to encode consecutive <1/0 €<1/0 in data. This may be used to prevent unbound expansion of data that contains many <1/0 patterns.
Syntax:		+FDD=<value
Defined Values:		<value> Decimal number corresponding to the selected option. For modem decode of <DLE><SUB>, the defined range are: 0 <DLE> <DLE> or discard (default and only) 1 <DLE> <DLE> (not supported) For modem encoding of <1/0> <1/0>the defined values are: 0 <DLE> <DLE> <DLE> <DLE> (default and only) 1 <DLE> <SUB> (not supported)
Reporting Current or Selected Values:		Command: +FDD? Response: +FDD: <value> Example: +FDD: 0 For the default setting.
Reporting Supported Range of Parameter Values:		Command: +FDD=? Response: +FDD: (<value> range) Example: +FDD: (0)
Command:	+FIT	DTE Inactivity Timeout
Description:		This command specifies a DTE inactivity timeout value that allows the modem to break away from an unsuccessful connection attempt at any stage of a facsimile transfer. The DTE inactivity timer operates only while the modem is off-hook.
Syntax:		+FIT=<time ,action
Defined Values:		<time The <time parameter indicates the DTE inactivity timeout in seconds. The value of 0 indicates that timeout is disabled (default). The required timeout range is 1 to 255 seconds. The inactivity timer starts when the modem has taken some action that requires DTE response. If the DTE does respond, the modem resets the inactivity timer. Inactivity timer related events are listed in Table 4-3. <action The <action parameter has two meanings. 0 Upon timeout, the modem will go on-hook, executing an implied ATH command; then reset to +FCLASS 0. 1 Upon timeout, the DCE will only go on-hook.

Reporting Current or Selected Values:

Command: +FIT?
 Response: +FIT: <time> ,action
 Example: +FIT: 0,0 For the default settings.

Reporting Supported Range of Parameter Values:

Command: +FIT?
 Response: +FIT: (<time> range), (<action> range)
 Example: +FIT: (0-255),(0-1)

Table 4-3. Inactivity Timer Start and Stop Events

On-line state	Start timer event	Stop timer event
Waiting for a command	modem sends final result code	DTE sends AT or "at"
Waiting for transmit data	modem sends CONNECT after +FTM or +FTH command	DTE sends data
Waiting for transmit data	modem sends <XON or sets CTS ON	DTE sends data
Waiting to deliver received data	modem sends <XOFF after +FRM or +FRH command	DTE sends <XON
Waiting to deliver received data	DTE sets V.24 Ckt 133 OFF after +FRM or +FRH command	DTE sets V.24 Ckt 133 ON

Command: +FPR Fixed DTE Rate

Description: This numeric extended-format parameter specifies the data rate at which the modem will accept commands during on-line operation. It may be used to select operation at rates at which the modem is not capable of automatically detecting the data rate being used by the DTE. Specifying a value of 0 disables the function and allows operation only at rates automatically detectable by the modem. The specified rate takes effect following the issuance of any result code(s) associated with the current command line. The <rate> specified does not apply in OnLine Data State if Normal Mode (Direct Mode) of operation is selected.

Syntax: +FPR=<rate code>
Defined Values: <rate code> Specifies the DTE-modem interface operation rate in bits/s with a rate code. The available rate codes are:
 0 Automatic detection (default)
 1 2400 bits/s (executes +IPR=2400)
 2 4800 bits/s (executes +IPR=4800)
 4 9600 bits/s (executes +IPR=9600)
 8 19200 bits/s (executes +IPR=19200)
 10 38400 bits/s (executes +IPR=38400)
 18 57400 bits/s (executes +IPR=57400)
 If unspecified or set to 0, automatic detection is selected and the character format is also forced to autodetect, +ICF=0.
 If the rate specified is not supported by the modem, an ERROR result code will be returned.

Reporting Current or Selected Values:

Command: +FPR?
 Response: <rate code>
 Example 1: 0 For automatic rate detection.
 Example 2: 18 For 57600 bits/s.

Reporting Supported Range of Parameter Values:

Command: +FPR=?
 Response: (<rate code> range)
 Example: (0,1,2,4,8,10,18)

Command:	+FMI?	Request Manufacturer Identification
Description:		This command causes the modem to report the modem product manufacturer.
Syntax:		+FMI?
Typical Response:		CONEXANT OK
Command:	+FMM?	Request Model Identification
Description:		This command causes the modem to report the modem product model.
Syntax:		+FMM?
Typical Response:		V90 OK
Command:	+FMR?	Request Revision Identification
Description:		This command causes the modem to transmit one or more lines of information text identifying the modem version, revision level or date.
Syntax:		+FMR?
Typical Response:		V3.001-V90_2M_DLS OK
Command:	+FLO	Flow Control
Description:		This parameter allows the DTE to identify and select the type of flow control used.
Syntax:		+FLO=<method>
Defined Values:		<method> Decimal number corresponding to the selected option. 0 XON/XOFF and RTS/CTS flow control turned off. 1 Use XON/XOFF flow control in either direction. 2 Use RTS for flow control of the modem by the DTE; use CTS for flow control of the DTE by the modem.
Reporting Current or Selected Values:		Command: +FLO? Response: +FLO: <method> Example: +FLO: 0 For the default setting.
Reporting Supported Range of Parameter Values:		Command: +FLO=? Response: +FLO: (<method>range) Example: +FLO: (0-2)
Result Codes:		OK <method> = 0-2. ERROR Otherwise.

Examples

Examples of calling (transmitting) and answering (receiving) one page using fax class 1 commands are shown in Table 4-4 and Table 4-5, respectively. The examples show the interchange between the DTE and the modem for various cases. Comments are included to explain how to handle various situations. Commands and responses are in upper case (e.g., AT+FRH=3) and comments are in lower case. All streams of data denoted by <..frame> are terminated by the <DLE><ETX> characters.

Table 4-4. Fax Class 1 Calling Sequence (Transmitting a Single Page)

DTE Commands	Modem Responses	Local Modem Action	Remote Station Action	Notes
AT+FCLASS=1	OK	Set Class 1		
ATDT<string>	CONNECT <NSF frame> <DLE><ETX> OK	Dial and send CNG Look for V.21 Detect flags	Answer send CED, V.21 Send HDLC flags Send NSF frame	AT+FRH=3 implied by dialing with +FCLASS=1.0
AT+FRH=3	CONNECT <CFI frame data> <DLE><ETX> OK	Detect flags get CSI get FCS accept FCS	send CSI frame check FCS	Frame status OK
AT+FRH=3	CONNECT <DIS frame data> <DLE><ETX> OK	Detect flags get DIS get FCS accept FCS	send DIS frame check FCS	DTE must detect final frame bit to anticipate loss of carrier
AT+FRH=3	NO CARRIER	detect loss-of-carrier	drop carrier	
AT+FRH=3 <TSI frame data> <DLE><ETX> <DCS frame data> <DLE><ETX>	CONNECT CONNECT OK	send V.21 carrier send flags send TSI frame send FCS send flags send DCS frame send FCS, flags drop carrier	detect carrier detect flags get TSI frame get DCS frame	Final frame bit clear tells the modem to expect another frame. Final frame bit set tells the modem not to expect another frame
AT+FTS=8; +FTM=96 <TCF data pattern> <DLE><ETX>	CONNECT OK	wait 80 ms send V.29 carrier send TCF data drop carrier	detect carrier get TCF data	
AT+FRH=3	CONNECT <CFR frame data> <DLE><ETX> OK	detect carrier detect flags get CFR frame check FCS accept FCS	send V.21 carrier send flags get CRF frame send FCS	Final frame bit set. frame OK
AT+FRH=3	NO CARRIER	detect loss-of-carrier	drop carrier	
AT+FTM=96 <page image data> <DLE><ETX>	CONNECT OK	send V.29 carrier send page data drop carrier	detect carrier receive page	
AT+FTS=8; +FRH=3 <EOP frame data> <DLE><ETX>	CONNECT OK	wait 80 ms send V.21 carrier send flags send EOP frame send FCS drop carrier	detect carrier detect flags receives EOP	final frame
AT+FRH=3	CONNECT <MCF frame data> <DLE><ETX> OK	detect carrier detect flags get MCF frame check FCS accept FCS	send V.21 carrier send flags get MCF frame send FCS	Final frame bit set. frame OK
AT+FRH=3	NO CARRIER	detect loss-of-carrier	drop carrier	
AT+FRH=3 <DNC frame> <DLE><ETX>	CONNECT OK	send V.21 carrier send flags send DNC frame send FCS drop carrier	detect carrier detect flags receive DC NC	final frame
ATH0	OK	hang up	hang up	

Table 4-5. Fax Class 1 Answering Sequence (Receiving a Single Page)

DTE Commands	Modem Responses	Local Modem Action	Remote Station Action	Notes
AT+FCLASS=1	OK	Set Class 1		
	RING<-	detect ringing	dials [,send CNG]	
ATA <CSI frame data> <DLE><ETX> <DIS frame data> <DLE><ETX>	CONNECT CONNECT OK	off-hook, send CED, send V.21 carrier send flags send CSI frame send FCS send flags send DIS data send FCS and flags drop carrier	get CED, detect carrier detect flags receive CSI get FCS get flags get DIS get flags	AT+FRH=3 implied by answering with +FCLASS=1.0. not final frame final frame
AT+FRH=3	CONNECT <TSI frame data> <DLE><ETX> OK	detect carrier detect flags receive TSI receive FCS accept FCS	send V.21 carrier send flags send TSI frame send FCS	frame OK
AT+FRH=3	CONNECT <DCS frame data> <DLE><ETX> OK	receive DCS receive FCS accept FCS	send DCS frame send FCS	final frame bit set frame OK
AT+FRH=3	NO CARRIER	detect loss-of-carrier	drop carrier	DTE did not check final frame bit and issued +FRH=3
AT+FTM=96	CONNECT <TCF data> <DLE><ETX> OK	detect carrier receive TCF detect loss-of-carrier	wait 75 ms send V.29 carrier send TCF data drop carrier	
AT+FRH=3 <CFR frame data> <DLE><ETX>	CONNECT OK	send V.21 carrier send flags get CRF frame send FCS drop carrier	detect carrier detect flags receive CFR	final frame
AT+FTM=96	CONNECT <page image data> <DLE><ETX> NO CARRIER	detect carrier receive page detect loss-of-carrier	send V.29 carrier send page data drop carrier	
	CONNECT <EOP frame data> <DLE><ETX> NO CARRIER	detect carrier detect flags receive EOP receive FCS accept FCS	wait 75 ms send V.21 carrier send flags send EOP frame send FCS	frame OK
AT+FRH=3	NO CARRIER	detect loss-of-carrier	drop carrier	
AT+FRH=3 <MCFame data> <DLE><ETX>	CONNECT OK	send V.21 carrier send flags get MCF frame send FCS accept FCS	detect carrier detect flags receive MCF frame	final frame
AT+FRH=3	CONNECT <DCN frame data> <DLE><ETX> OK	detect carrier detect flags receive DCN receive FCS accept FCS	send V.21 carrier send flags send DCN frame send FCS	frame OK
AT+FRH=3	NO CARRIER	detect loss-of-carrier	drop carrier	end of session
ATH0	OK	hang up		

Chapter 5 – Fax Class 2 Commands

The Fax Class 2 commands are summarized in Table 5-1.

Table 5-1. Fax Class 2 Commands

Command	Function
Service Class ID	
+FCLASS=	Service Class
Class 2 Action Commands	
D	Originate a Call
A	Answer a Call
+FDT	Data Transmission
+FET=N	Transmit Page Punctuation
+FDR	Begin or Continue Phase C Receive Data
+FK	Session Termination
Class 2 DCE Responses	
+FCON	Facsimile Connection Response
+FDCS:	Report Current Session
+FDIS:	Report Remote Identification
+FCFR	Indicate Confirmation to Receive
+FTSI:	Report the Transmit Station ID
+FCSI:	Report the Called Station ID
+FPTS:	Page Transfer Status
+FET:	Post Page Message Response
+FHNG	Call Termination with Status
Class 2 Session Parameters	
+FMFR?	Identify Manufacturer
+FMDL?	Identify Model
+FREV?	Identify Revision
+FDCC=	DCE Capabilities Parameters
+FDIS=	Current Sessions Parameters
+FDCS=	Current Session Results
+FLID=	Local ID String
+FCR	Capability to Receive
+FPTS=	Page Transfer Status
+FCR=	Capability to Receive
+FAE	Adaptive Answer
+FBUF?	Buffer Size (Read Only)
+FPHCTO	Phase C Time Out
+FAXERR	Fax Error Value
+FBOR	Phase C Data Bit Order

Command and Syntax Guidelines

Mode Entry Commands

+FCLASS=2 - Select Facsimile Class 2 Mode

+FCLASS=2 selects the Fax Class 2 Mode (see Generic Modem Control).

DTE Commands

The ISO 646 character set (CCITT T.50 International Alphabet 5, American Standard Code for Information Interchange) is used for the issuance of commands and responses. Only the low-order 7 bits of each character are used for commands or parameters; the high order bit is ignored. Upper case characters are equivalent to lower case characters. For Phase C data transmission or reception, all 8 bits are needed.

DTE Command Lines

A command line is a string of characters sent from a DTE to the modem (DCE) while the modem is in a command state. A command line has a prefix, a body, and a terminator. Each command line (with the exception of the *A/* command) must begin with the character sequence AT and must be terminated by a carriage return. Commands entered in upper case or lower case are accepted, but both the A and T must be of the same case, i.e., "AT" = ASCII 065, 084 or "at" = ASCII 097, 116. The body is a string of commands restricted to printable ASCII characters (032 - 126). Space characters (ASCII 032) and control characters other than CR (ASCII 013) and BS (ASCII 010) in the command string are ignored. The default terminator is the ASCII <CR> character. Characters that precede the AT prefix are ignored. The command line interpretation begins upon receipt of the carriage return character.

Facsimile Command Syntax

After the "AT" or "at" prefix, facsimile commands use extended syntax. Each command is preceded by the "+F" character and consists of single characters and a decimal parameter (if applicable) terminated by the semicolon ":" character (ASCII 059) or by the <CR> that terminated the command line. A missing decimal parameter is evaluated as 0.

For example, the command to instruct the modem to automatically answer a data or fax call and also enable reception is:

```
AT+FAE=0; +FCR 1 <CR>
```

Basic data mode and fax service class mode select commands are:

```
AT+FCLASS=0 <CR> for Data Mode
AT+FCLASS=1 <CR> for Service Class 1 Fax
AT+FCLASS=1.0 <CR> for Service Class 1.0 Fax
AT+FCLASS=2 <CR> for Service Class 2 Fax
```

In Class 2, the DCE makes and terminates calls, manages the communication session and negotiates (T.30 protocol) and transports the image data to DTE. The T.4 protocol management of image data, etc., is done by DTE.

The response to

```
AT+FCLASS= 0<CR>    in Data Mode
or
AT+FCLASS=2<CR>    in Service Class 2 Fax
is
OK
```

The service class may be set by the DTE from the choices available using the "+FCLASS=<VALUE>" command.

General Rules

1. +Fnnn commands must be entered completely, otherwise an ERROR response is sent.
2. All response messages are preceded and followed by <CR><LF>. Multiple response commands (e.g., +FDIS: +FCSI: and +FDCS:) will, therefore, appear to have a blank line between them.
3. Fax Class 2 commands can be separated by the “;” character. The “;” character can be omitted if desired. Non-data commands cannot be separated by the “;” which is allowed as a dial modifier.
4. All Class 2 commands are assumed to be the final command on a command line. Additional characters will be ignored.
5. An ERROR message will be generated if any of the following conditions occur:
 - a. A Class 1 command is received while in Class 2.
 - b. A Class 2 command is received while in Class 1.
 - c. A Class 1 or Class 2 action command is received while in data modem mode.
 - d. A Class 2 read-only parameter is given the “=” form of a +F command (e.g., AT+FAXERR=5).
 - e. A Class

Serial Port Speed and Flow Control

During fax mode, the DTE-DCE port speed is 19200 bps.

The DCE provides a speed buffer of 1024 bytes and provides the DC1/DC3 (XON/XOFF) or RTS/CTS method of controlling the data into the buffer. This flow control is controlled by the &K3 or &K4 command.

This method of data flow control is available only for DTE to DCE direction of data. There is no provision for data flow control from DCE to DTE.

Data Stream Termination

The DCE exchanges streams of data with the DTE while executing data transfer commands. These data streams use the termination described in Section 3.2/ISO 2111.

The ASCII <DLE> character (016) is used as a special character to shield special characters. The <DLE><ETX> character pair (<106><003>) is used to mark the end of a stream. The following patterns are used:

- any data...<DLE><ETX> end of stream
- any data...<DLE><DLE> single <DLE> in data
- any data...<DLE><any byte> delete <DLE><any byte>

DTE to DCE Streams

The DCE filters the data stream from the DTE, and removes all character pairs beginning with <DLE>. The DCE recognizes <DLE><ETX> as the stream terminator. The DCE recognizes <DLE><DLE> and reinserts a single <DLE> in its place.

The DTE must filter stream data to the DCE, and insert extra <DLE> characters ahead of data.

DCE to DTE Streams

The DTE must filter the data stream from the DCE, and remove all character pairs beginning with <DLE>. The DTE must recognize <DLE><ETX> as the stream terminator. The DTE must recognize <DLE><DLE> and reinsert a single <DLE> in its place.

The DCE filters stream data to the DTE, and inserts extra <DLE> characters ahead of data.

Auto Answer

The DCE can answer as a data DCE or as a fax DCE. It can answer the call adaptively, i.e., it can determine whether the call is 'data' or 'fax'. The +FAA parameter controls this feature. Fax adaptive answer operates only when +FCLASS=0.

AT+FAA=1 ; Auto answer as a facsimile or a data modem depending on the call
CONNECT XXXX ; DCE status response if data call
+FCON ; DCE status response if fax call

Identification of T.30 Options

Group 3 devices negotiate session parameters in DIS, DCS, and DTC frames. These parameters are defined in Table 5-2.

Session Status Reporting

The DCE provides reports to the DTE on the status of a session. The DCE provides the following status reports:

1. Connection and hang up status:
+FCON
+FHNG:<0-255>
2. Requested DIS session parameters +FDIS: <string> reports remote facsimile capabilities.
Syntax: +FDIS: VR, BR, WD, LN, DF, EC, BF, ST
3. +FDCS: <string> reports the negotiated parameters
4. Phase C prompts:
XON, XOFF, DC2
5. Phase C base status reports: depending upon copy quality and related end-of page status:
+FPTS: <1-5>

Procedure Interrupt Negotiation

CCITT allows a station to request a procedure interruption at the end of a page. This request is passed between stations by the PIP, PIN, and PRI-Q messages.

Service Class 2 Identification and Selection

Three commands report identification and selection information. Each of these three commands cause the DCE to send a message to the DTE.

+FMFR? - Request Manufacturer Identification

The +FMFR? command causes the DCE to send a message identifying the DCE product manufacturer. The default message is:

```
CONEXANT  
OK
```

+FMDL? - Identify Product Model

The +FMDL? command causes the DCE to send a message identifying the DCE product model.

+FREV? - Identify Product Revision

The +FREV? command causes the DCE to send a message identifying the DCE product model revision number. The message format is the same as the AT13 message, e.g.:

```
VX.X-F_A  
OK
```

Service Class 2 Action Commands

These commands transfer data, and punctuate sessions. They also release specific T.30 messages. All action commands must be the last command on a command line as indicated by the terminating <CR>.

All action commands initiate processes. The modem will not accept other commands from the DTE until the modem issues a final result code (e.g., OK, CONNECT). The modem will abort the process if it receives any character before the final result code is issued.

Command: **ATD Originate a Call**

Syntax: ATD...<CR>

The DCE can support a DTE command to originate a call using the ATD command (see Data Commands).

If this command is unsuccessful, the DCE reports an appropriate failure or error type result code such as NO CARRIER, NO DIAL TONE, or BUSY (see S-Parameters).

If this call is successful, the typical DCE response is:

```
ATDnn..nn (go off-hook, dial, get CED)
+FCON (DCE detects flags)
[+FCSI:<remote ID string>]
+FDCS:<T.30 subparameter string>
OK
```

The DCE dials, detects call progress, and generates the CNG tone. It then waits for a DIS frame. On detection of the first Phase B preamble (V.21 ch. 2 modulated by 300 bps HDLC flags), it reports the "+FCON" message to the DTE. The DCE then switches to 19200 bps.

The DCE generates a DCS frame based on the received DIS frame and on the previously set +FDIS parameter. A +FDT command from the DTE releases the DCE to transmit that DCS frame.

The DCE reports the initial received T.30 negotiation messages, including the DIS frame and the optional CSI ID string. The +FDIS: report is followed by the OK final result code.

Command: **ATA - Answer a Call**

The DCE can support a DTE command to answer an incoming call using the ATA command (see Data Commands).

The DTE may issue an Answer command in response to an incoming ring.

If the Answer command is unsuccessful, the DCE will report an appropriate failure or error type result code, such as NO CARRIER (see S-Parameters).

Manual Call Answer

If this call is successful, the typical DCE response (answer and receive) is:

```
+FCON
[+FTSI:<remote ID string>]
+FDCS:<T.30 subparameter string>
OK
(DTE should issue +FDR command here)
```

Upon receipt of an Answer command from the DTE, the DCE answers and generates the CED tone. The DCE then generates a DIS frame (derived from the +FDIS parameter) and hunts for the first T.30 negotiation frames. Upon detection of the first Phase B preamble (V.21 ch 2 modulated by 300 bps HDLC flags), it reports the "+FCON" message to the DTE.

The DTE should report the initial received T.30 negotiation messages, including the DCS frame. The +FDCS: report will be followed by the OK final result code.

Automatic Answer

The modem provides for automatic answering of incoming calls. If configured for automatic answer, the modem answers an incoming call in compliance with T.30, and reports the same messages as described for manual answer.

Connection as a Data Modem

If configured to do so by the +FAA parameter, the DCE will adaptively answer as a facsimile DCE or as a data DCE. If the DCE answers as a data DCE, it resets the +FCLASS parameter to 0 and issues the appropriate final result code (e.g., CONNECT, or NO CARRIER) to the DTE.

Command: +FDT Data Transmission

Syntax: +FDT <CR>

The +FDT command prefixes Phase C data transmission. When the DCE is ready to accept Phase C data, it issues the negotiation responses and the CONNECT result code to the DTE.

In Phase B, the +FDT command releases the DCE to proceed with negotiation, and releases the DCS message to the remote station. In Phase C, the +FDT command resumes transmission after the end of a prior transmit data stream.

Initiate Page Transmission

Phase B DCE polled response:

```
[+FCSI:<remote ID string>] - if new CSI received
[+FDIS:<subparameters from remote station>] - if new DIS received
+FDCS:<T.30 subparameter string>
CONNECT
<XON> - when ready for data
```

After placing a call, or after finishing a document exchange, the DTE may command the DCE to re-enter T.30 Phase B to attempt to negotiate a document transmission.

Continue a Page

```
CONNECT
<XON>
```

The DTE may issue more than one +FDT command for a given page, so that different files may be concatenated together. These files must have the same format.

Phase C Data Framing

Phase C data must be presented to the DCE in stream mode. The DCE expects Phase C data to follow until it detects <DLE><ETX> termination characters. The DCE will filter the stream as described in Section 6.1.2.

The DCE will acknowledge the end of the data by returning the OK result code to the DTE.

If there is data underrun before the next +FDT or +FET= command, the DCE will zero-fill the pad as per T.4 until the Phase C timeout (+FPHCTO) is reached, or until more data is received. The DCE appends an RTC pattern to the transmit data after an +FET= command is received from the DTE.

Phase C Data Format

The Phase C data will be of the format specified by the negotiated T.30 DCS frame. The +FDCS:<string> response is defined in Section 6.4.2. The subparameter values are described in Table 5-2.

The DCE will use the negotiated minimum Scan Time parameter from the DCS frame, and insert sufficient fill bits to pad each line to the minimum scan time. This is reported in the +FDCS:ST subparameter.

If the DCE finds more than one consecutive EOL in Phase C data (e.g., RTC), it will send only one EOL.

1. Phase C data must conform to T.4 specifications.
2. The DTE need not include a final RTC, since the DCE will append an RTC in response to an FET= command.
3. Some facsimile machines may treat two EOLs as an RTC.

<CAN> - Escape from Transmission

The DCE may request the DTE to halt Phase C transmission, by sending a cancel <CAN> character (024) to the DTE. In this case, the DTE should terminate Phase C transmission, issue <CAN>, and wait for the OK response code from the DCE.

Table 5-2. T.30 Session Subparameter Codes

Label	Function	Value	Description	
VR	Vertical Resolution	0	Normal, 98 lpi	
		1	Fine, 196 lpi	
BR	Bit Rate (See Note 1)		+FDCS (originate)	+FDIS (answer)
		0	2400 bps/V.27 ter	V.27 ter (2400 only)
		1	4800 bps/V.27 ter	V.27 ter
		2	7200 bps/V.29	V.29, V.27 ter
		3	9600 bps /V.29 or V.17	V.29, V.27 ter
		4	12000 bps/V.33 or V.17	V.17, V.33, V.29, V.27 ter
WD	Page Width	5	14400 bps/V.33 or V.17	V.17, V.33, V.29, V.27 ter
		0	1728 pixels in 215 mm	
		1	2048 pixels in 255 mm	
		2	2432 pixels in 303 mm	
		3*	1216 pixels in 151 mm	
LN	Page Length	4*	4864 pixels in 107 mm	
		0	A4, 297 mm	
		1	B4, 364 mm	
		2	unlimited length	
DF	Data Compression Format	0	1-D modified Huffman	
		1*	2-D modified Read	
		2*	2-D uncompressed mode	
		3*	2-D modified modified Read	
EC	Error Correction (Annex A/T.30)	0	Disable ECM	
		1*	Enable ECM, 64 bytes/frame	
		2*	Enable ECM, 256 bytes/frame	
BF	Binary File Transfer	0	Disable BFT	
		1*	Enable BFT	
ST	Scan Time/Line		VR = normal	VR = fine
		0	0 ms	0 ms
		1	5 ms	5 ms
		2	10 ms	5 ms
		3	10 ms	10 ms
		4	20 ms	10 ms
		5	20 ms	20 ms
		6	40 ms	20 ms
7	40 ms	40 ms		

Notes: 1. CCITT T.30 does not provide for the answering station to specify all speeds exactly using the DIS frame. Implementation of some BR codes (e.g., code 2) by an answering DCE is manufacturer specific.
* Not supported.

Command: +FET Transmit Page Punctuation**Description:**

This command is used to punctuate page and document transmission after one or more +FDT commands. This command generates T.30 Post Page Messages selected by the <ppm> code (Table 5-3).

The +FET=<ppm> command indicates that the current page is complete; no more data will be appended to it. The value indicates whether there are any additional pages are to be sent and, if so, whether there is a change in any of the document parameters.

The DTE can command the DCE to generate PRI-Q messages with the +FET=<ppm> command using ppm codes 4-6 (Table 5-3).

This command must be sent within the time out specified by +FPHCTO after sending Phase C data, or else the DCE will end the page and document transmission. If the Phase C timeout is reached, the DCE sends an EOP post page message and terminates the session.

The remote facsimile station should respond to the post page message with a post page response. The DCE will report this using the +FPTS:<ppr> response (Table 5-4).

Syntax:**DCE response:****End a Page**

The +FET= command causes the DCE to append an RTC (6 EOL) pattern as needed and enter Phase D by sending the selected T.30 Post Page message.

The +FET=1 (EOM) command signals the remote station that the next document will have a new DCS negotiated; this causes the session to re-enter Phase B.

+FET=<ppm>[,<pc>,<bc>,<fc>]
+FPTS:<ppr> - when receive from remote OK

Table 5-3. T.30 Post Page Message Codes

ppm Code	Mnemonic	Description
0	[PPS-]MPS	Another page next, same document
1	[PPS-]EOM	Another document next
2	[PPS-]EOP	No more pages or documents
3	PPS-NULL	Another partial page next
4	[PPS-]PRI-MPS	Another page, procedure interrupt
5	[PPS-]PRI-EOM	Another doc., procedure interrupt
6	[PPS-]PRI-EOP	All done, procedure interrupt
=8+ppm		Post Page Message (ppm code)

Table 5-4. T.30 Post Page Response Messages

ppr Code	Mnemonic	Description
1	MCF	Page good
2	RTN	Page bad; retrain requested
3	RTP	Page good; retrain requested
4	PIN	Page bad; interrupt requested
5	PIP	Page good; interrupt requested

Command: +FDR Begin or Continue Phase C Receive Data**Description:**

The +FDR command initiates transition to Phase C data reception. This can occur after answering, dialing, a document is received, or a page is received.

The DCE reports the negotiated T.30 parameters, with the remote ID information if available. When the DCE is ready to commence data transfer, it issues a CONNECT response code. If the DCE cannot resume data transfer because there is no more data, it responds OK. When the DTE is ready to accept data, it issues an <DC2> character (018) to the DCE.

If the DTE issues an <XOFF> character to the DCE for flow control, the DCE signals the DTE when its buffers are empty by sending a <DLE><DC2> (<016><018>) character pair.

When the DCE delivers the last byte of a page, the DCE reports the Page Transfer Status via the +FPTS:<ppr> response (Table 5-4).

After a Page Transfer Status Report, the DCE reports the post page message from the remote facsimile station via the +FET:<ppm> response (Table 5-3) which signals the intentions of the remote station.

The DCE holds the post page response message to the remote facsimile station (MCF, etc.), represented in the +FPTS parameter until the next +FDR command. The DTE may modify the +FPTS parameter before issuing the +FDR command which releases that message. The DTE must issue a +FDR command to release Post Page Messages.

Syntax:

+FDR <CR>

Default value:

3 seconds in some places

Initiate Document Reception

The +FDR command may be issued in Phase B after an answer command, or in Phase B after a previous document. The DCE response in stream mode is:

```
+FCFR when CFR sent
[+FTSI:<remote ID string>] if new TSI received
+FDCS:<T.30 subparameter string>] if new DCS
CONNECT
(<DC2> needed from DTE here)
<Phase C data stream>
<DLE><ETX>
+FPTS:<ppr>, <lc> [,<blc>, <cbcl>]
+FET:<ppm>
OK
(DTE must issue +FDR command to release post page response)
```

Continue Document Reception

The DTE may issue a +FDR command in Phase D, which releases the post page message, and indicates readiness to receive another page after receipt of a Multipage (+FET:0) or PPS-NUL (+FET:3) message. The DCE response will be:

```
CONNECT
(<DC2> needed from DTE here)
<Phase C data stream>
<DLE><ETX>
+FPTS:<ppr>, <lc> [,<blc>, <cbcl>]
+FET:<ppm>
OK
(DTE must issue +FDR command to release post page response)
If done receiving:
+FHNG: <hangup cause code>
OK
Continue page reception
```

Phase C Data Framing

Phase C data may be presented to the DTE in stream mode. The DCE will transfer a stream of data to the DTE, followed by the <DLE><ETX> stream termination characters.

The DCE will filter the stream as described in Voice Commands -- <DLE> Shielded Codes Sent to the Modem (DCE).

Phase C Data Format

The received data format is negotiated under T.30 reported by the +FDCS:VR,BR,WD,LN,DF,EC,BF,ST response.

The DCE will delete the terminating RTC (6 EOLs) patterns.

<CAN> - Escape from Reception

From the +FDR command until the end of Phase D Date, the DCE is in a data transfer state, and will not respond to DTE command characters. The DCE will respond to three ASCII control characters: <DC1> (017) and <DC3> (019) flow control characters, and cancel <CAN> (024).

Upon receipt of the <CAN> character, the DCE will terminate the reporting of received data by sending trailing <DLE><ETX> characters to the DTE, and will then execute an implied +FK command in order to conduct an orderly disconnection.

Command: +FK**Session Termination**

Description:

The +FK command causes the DCE to terminate the session in an orderly manner. In particular, the DCE will send a DCN message at the next opportunity and hang up. At the end of the termination process, the DCE will report the +FHNG response with result code (Table 5-5).

This operation can be invoked by using the cancel <CAN> character during Phase C data reception (see prior section).

The DCE will wait until the current page completes, unless the reception is of unlimited length; in that case, the DCE may halt reception and terminate the session at any time.

Syntax:

+FK

Command: +FCIG**Set Polling ID**

Description:

This command allows setting the Local Polling ID string used in a CIG frame. The syntax of this command is identical to +FLID.

Write syntax:

+FCIG="<local ID string>"

Valid value:

20-character ASCII string

Default value:

Empty

Command: +FLPL**Indicate a Document for Polling**

Description:

This command allows setting up an answering modem to know that it has a document available for polling. This allows a calling modem to receive this fax from the answerer.

Syntax:

AT+FLPL=?

0,1

OK

AT+FLPL=1

OK

AT+FLPL?

1

Command: +FSPL Enable Polling

Description: This command allows setting up an originating modem to be able to request to receive a document from a polled station.

Syntax: AT+FSPL=?
 0,1
 OK
 AT+FSPL=1
 OK
 AT+FSPL?
 1

Table 5-5. Hang Up Status Codes

Code	Cause Description
0-9	Call Placement and Termination
0	Normal and proper end of connection
1	Ring Detect without successful handshake
2	Call aborted, from +FK or AN
3	No Loop Current
10-19	Transmit Phase A & Miscellaneous Errors
10	Unspecified Phase A error
11	No Answer (T.30 T1 timeout)
20-39	Transmit Phase B Hangup Codes
20	Unspecified Transmit Phase B error
21	Remote cannot receive or send
22	COMREC error in transmit Phase B
23	COMREC invalid command received
24	RSPEC error
25	DCS sent three times without response
26	DIS/DTC received 3 times; DCS not recognized
27	Failure to train at 2400 bps or +FMINSF value
28	RSPREC invalid response received
40-49	Transmit Phase C Hangup Codes
40	Unspecified Transmit Phase C error
43	DTE to DCE data underflow
50-69	Transmit Phase D Hangup Codes
50	Unspecified Transmit Phase D error
51	RSPREC error
52	No response to MPS repeated 3 times
53	Invalid response to MPS
54	No response to EOP repeated 3 times
55	Invalid response to EOP
56	No response to EOM repeated 3 times
57	Invalid response to EOM
58	Unable to continue after PIN or PIP
70-89	Receive Phase B Hangup Codes
70	Unspecified Receive Phase B error
71	RSPREC error
72	COMREC error
73	T.30 T2 timeout, expected page not received
74	T.30 T1 timeout after EOM received
90-99	Receive Phase C Hangup Codes
90	Unspecified Receive Phase C error
91	Missing EOL after 5 seconds
92	Unused code
93	DCE to DTE buffer overflow
94	Bad CRC or frame (ECM or BFT modes)
100-119	Receive Phase D Hangup Codes
100	Unspecified Receive Phase D errors
101	RSPREC invalid response received
102	COMREC invalid response received
103	Unable to continue after PIN or PIP
120-255	Reserved Codes
Note: Some codes are not implemented.	

Service Class 2 DCE Responses

The DCE sends information responses to the DTE as a facsimile session proceeds. They indicate the state of the facsimile session and convey needed information. These messages are solicited messages generated in execution of DTE action commands. described in Fax Class 2 Commands section.

The DCE precedes and follows the information responses with <CR><LF>.

The DCE provides the on-line status of several session parameters when they are available during T.30 handshaking. These include the remote ID string and the DIS/DCS parameters. These responses report the T.30 session parameter frames. The subparameters are described in Table 5-2.

Command: **+FCON Facsimile Connection Response**

+FCON indicates connection with a fax machine. It is released by detection of HDLC flags in the first received frame. +FCON is generated in response to an Originate or Answer command.

Command: **+FDCS: Report Current Session Capabilities**

Description: +FDCS:<string> reports the negotiated parameters. Phase C data will be formatted as described by the subparameters. This message may be generated in execution of +FDT or +FDR commands before the CONNECT result code if new DCS frames are generated or received. (See Table 5-2.)

Syntax: +FDCS:VR,BR,WD,LN,DF,EC,BF,ST

Command: **+FDIS: Report Remote Station Capabilities**

Description: +FDIS:<string> reports remote facsimile station capabilities and intentions. The parameters are provided in ASCII notation. (See Table 5-2.) This message is generated in execution of Originate, Answer, +FDT, or +FDR commands.

Syntax: +FDIS:VR,BR,WD,LN,DF,EC,BF,ST

Command: **+FCFR Indicate Confirmation to Receive**

Description: The DCE sends a +FCFR response to the DTE upon reception of an acceptable TCF training burst and a valid DCS signal from the remote machine. This indicates that the DCE will receive Phase C data after the remote station receives the local DCE's CFR message. The +FCFR message is generated in execution of a +FDR command.

Syntax: +FCFR

Command: **+FTSI: Report the Transmit Station ID**

Description: This response reports the received transmit station ID string, if any. This message is generated in execution of Originate, Answer, +FDT, or +FDR commands.

Syntax: +FTSI: "<TSI ID string>" Transmit Station ID

Command: **+FCSI: Report the Called Station ID**

Description: This response reports the received called station ID string, if any. This message is generated in execution of Originate, Answer, +FDT, or +FDR commands.

Syntax: +FCSI: "<CSI ID string>" Called Station ID

Command: **+FPTS: Receive Page Transfer Status**

Description: The +FPTS:<ppr> is generated by the DCE at the end of Phase C data reception in execution of a +FDR command.

The <ppr> is generated by the DCE; it depends on the DCE capabilities at T.4 error checking. See Table 5-4 for <ppr> values.

The receiving DCE will count the lines. These values are;

<lc> = line count

<blc> = bad line count

<cblc> = <consecutive bad line count

A receiving DTE may inspect <ppr> and write a modified value into the +FPTS parameter. The DCE will hold the corresponding Post Page Response message until released by a +FDR command from the DTE.

Syntax: +FPTS:<ppr>, <lc> [,<blc>, <cblc>]

Command: +FET: Post Page Message Response

Description: The +FET:<post page message> response is generated by a receiving DCE after the end of Phase C reception on receipt of the post-page message from the transmitting station. The +FET:<ppm> response is generated in execution of a +FDR command.

The <ppm> codes respond to the T.30 post page messages (Table 5-3).

Syntax: +FET:<ppm>

Command: +FPTS: Transmit Page Transfer Status

Description: The +FPTS: response reports a <ppr> number representing the copy quality and related post-page message responses received from the remote DCE. The valid <ppr> values are defined in Table 5-4.

The +FPTS:<ppr> response is generated in execution of a +FET=<ppm> command.

Syntax: +FPTS:<ppr>

Command: +FHNG: Call Termination with Status

Description: +FHNG indicates that the call has been terminated. The hangup cause is reported and stored in the +FAXERR parameter for later inspection. The <hangup status code> values are described in Table 5-5.

+FHNG:<hsc> is a possible intermediate result code to any DTE action command described in Section 6.3. It is always followed by the OK final result code.

Upon termination of a call, the DCE determines the cause of termination and reports it as part of the FHNG:<hsc> response. It also stores this <hsc> code in the +FAXERR parameter for later inspection.

The hangup values are organized according to the phases of the facsimile transaction as defined by T.30. In the Figure A/T.30 flow charts, there are decision boxes labeled "Command Received?"; this is referred to as COMREC in the table. Similarly, decision boxes labeled "Response Received?" are referred to as RSPREC in the table. A COMREC error or RSPREC error indicates that one of two events occurred: 1) a DCN (disconnect) signal was received, or 2) an FCS error was detected and the incoming signal was still present after 3 seconds. (See Figure A/T.30).

The table values are in decimal notation. Leading zero characters are optional.

Syntax: +FHNG:<hangup status code>

Command: +FCIG: Report the Polled Station ID

Description: This response reports the received transmit station ID string, if any. This message is generated in execution of Originate, Answer, +FDT, or +FDR commands.

Syntax: +FCIG: "< ID string>" Polled Station ID

Command: +FDTC: Report the Polled Station Capabilities

Description: If the answerer has a document to poll, it would be communicated to the originator in bit 9 of the DIS frame. The originating station may elect to transmit a fax, and later, send SIG and DTC frames to pick up the polled document. The answering station would report the incoming DTC frame via the +FDTC: response message after command mode is canceled with the AT+FDR command.

Syntax: +FDTC: "< string>" Polled Station Capabilities

Command: +FPOLL Indicate Polling Request

Description: This message is sent to the DTE if the received DIS message indicates that the remote station has a document to poll (by bit 9 in the DIS) and polling has been enabled with the AT+FSPL command. The DTE may then decide to receive rather than transmit.

Syntax: +FPOLL:

Service Class 2 Parameters

All Service Class 2 parameters can be read, written, and tested for range of legal values by the DCE. The general syntax is described in the Voice Commands Overview section.

Group 3 FAX devices negotiate session parameters in DIS, DCS, and DTC frames. The following parameters are provided to condition the facsimile DCE for the capabilities it will offer and to report the session settings negotiated.

The three primary T.30 session parameters are +FDCC, +FDIS and +FDCS. They are compound parameters, using values listed in Table 5-2. Figure 5-1 illustrates their relationships.

Figure 5-1. T.30 Session Parameter Relationships

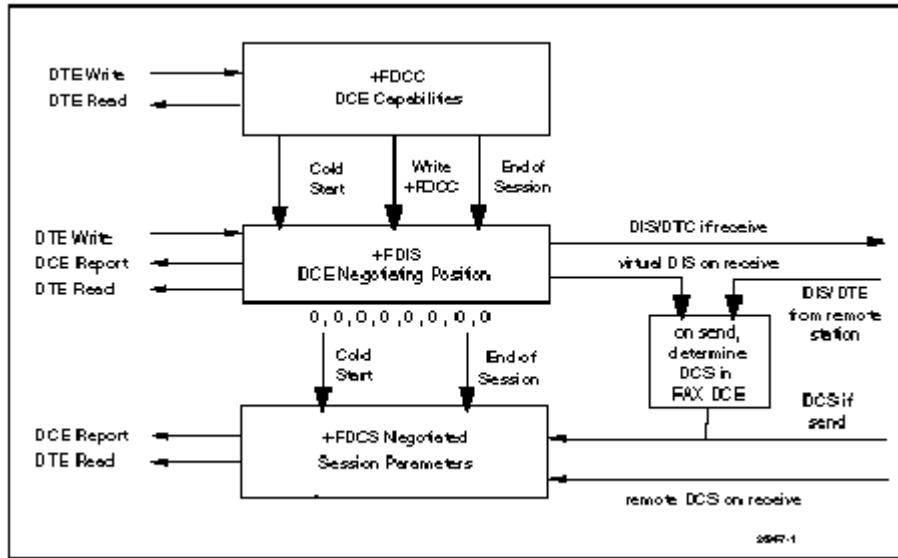

Command: +FDCC DCE Capabilities Parameters

Description: +FDCC allows the DTE to sense and constrain the capabilities of the facsimile DCE from the choices defined in CCITT T.30 Table 2. When +FDCC is modified by the DTE, the DCE copies +FDCC into +FDIS.

Write syntax: +FDCC=VR,BR,WD,LN,DF,ED,BF,ST

Valid values: See Table 5-2.

Default values: 0,3,0,2,0,0,0,0 (9600 bps fax models) or 0,5,0,2,0,0,0,0 (14400 bps fax models)

Command: +FDIS Current Sessions Capabilities Parameters

Description: The +FDIS parameter allows the DTE to sense and constrain the capabilities used for the current session. The DCE uses +FDIS to generate DIS or DTC messages directly, and uses +FDIS and received DIS messages to generate DCS messages. The DCE initializes the +FDIS parameter from the +FDCC parameter on initialization, when +FDCC is written, and at the end of a session.

Write syntax: +FDIS=VR,BR,WD,LN,DF,EC,BF,ST

Valid values: See Table 5-2.

Default values: 0,3,0,2,0,0,0,0 (9600 bps fax models) or 0,5,0,2,0,0,0,0 (14400 bps fax models)

Command: +FDCS Current Session Results Parameters

Description: The +FDCS parameter is loaded with the negotiated T.30 parameters for the current session. A transmitting DCE generates DCS; a receiving DCE gets DCS from the remote station. The DTE may read this parameter.

The +FDCS parameter is initialized 0,0,0,0,0,0,0,0 upon initialization and at the beginning of a session. If the DTE issues a +FDCS? command in the initial state, the DCE reports:

```
<CR><LF>0,0,0,0,0,0,0,0<CR><LF>
```

The contents of +FDCS are spontaneously reported during execution of +FDR or +FDT commands by the +FDCS:VR,BR,WD,LN,BF,EC,BF,ST response using the same compound parameter format.

Several commands and responses reference T.30 session negotiated parameters. These are described by a set of common subparameters. These subparameters are described in Table 5-2 with notes. Optional parameter values are marked with an *. Unspecified parameter values are reserved for future use.

The +FDCC, +FDIS, and +FDSC compound parameters use these session parameters (On writes, unspecified subparameters are unchanged.)

The +FDIS:, +FDSC:, and +FDTC: session report responses use these subparameters.

For test response, ranges of values are reported for each subparameter enclosed in parentheses characters. For example, a DCE response to +FDCC=? could report: <CRLF> (0,1), (0-5), (0-3), (0-2), (0-2), (0-2), (0), (0-7) <CRLF> (14400 fax models)

Read syntax: +FDCS?

DCE response: +FDCS=VR,BR,WD,LN,DF,EC,BF,ST

or

+FDSC=

Valid values: See Table 5-2.

Default values: 0,0,0,0,0,0,0,0

Example: +FDIS=0,5,0,2,0,0,0,1 =

VR = 0 98 dpi vertical resolution,

BR = 5 14400 bit/s

WD = 0 1728 pixels,

LN = 2 unlimited length

DF = 0 1-D modified Huffman coding,

EC = 0 no ECM,

BF = 0 no BFT,

ST = 1 5 ms scan time.

Command: +FLID= Local ID String

Description: If FLID is not a null string, it generates a TSI or CSI frame. Table 3/T.30 includes digits 0-9, "+", and space.

If the DCE supports use of Table 3/T.30 only, the response to a +FLID=? command is "(20) (32, 43, 48-57)." If the DCE supports printable ASCII <, the response is: "(20) (32-127)<CRLF>." The first "(20)" represents string length: the second (character values) field reports supported string values.

1. The string is saved in RAM.

2. Non-numeric characters are not filtered out.

3. The string is right justified.

Write syntax: +FLID="<local ID string>"

Valid value: 20-character ASCII string

Default value: Empty

Command: +FCR Capability to Receive

Description: +FCR=0 indicates that the DCE will not receive message data. This can be used when the DTE has insufficient storage. The DCE can send and can be polled for a file. +FCR is sampled in CCITT T.30 Phase A and Phase D.

Write syntax: +FCR=<value>

Valid values: 0 or 1

Default value: 0

Command: +FPTS= Page Transfer Status

Description: The +FPTS parameter contains a value representing the post page response, including copy quality and related end-of-page status. These values correspond to post page response messages defined in T.30. The receiving DCE sets this parameter after it receives a page of Phase C data. The transmitting DCE sets this parameter with the status reported by the receiving station. The DTE may inspect or modify this parameter.

The set of <ppr> values is defined in Table 5-4. These values are also reported in the +FPTS response to the +FDR command.

Write Syntax: +FPTS=<ppr>

Valid values: 1, 2, 3, 4, 5

Default value: 0

Command: +FCQ Copy Quality Checking

Description: This parameter controls Copy Quality checking by a receiving facsimile DCE. The DCE returns +FCQ=0 which indicates the DCE does no quality checking. The DCE will generate Copy Quality OK (MCF) responses to complete pages, and set +FPTS=1.

Write syntax: +FCQ=<value>

Valid values: 0

Default value: 0

Command: +FPHCTO DTE Phase C Response Time-out

Description: The +FPHCTO command determines how long the DCE will wait for a command after reaching the end of data when transmitting in Phase C. When this time-out is reached, the DCE assumes there are no more pages and no documents to send. It then sends the T.30 EOP response to the remote device.

Write syntax: +FPHCTO=<value>

Valid values: 0 - 255, 100 millisecond units.

Default value: 30

Command: +FAXERR T.30 Session Error Report

Description: This read-only parameter indicates the cause of the hangup. Table 5-5 shows the valid values for this parameter as well as the meaning of the each value. +FAXERR is set by the DCE at the conclusion of a fax session. The DCE resets +FAXERR to 0 at the beginning of Phase A off-hook time.

Read syntax: +FAXERR= <table value>, read only

Valid values: 0 - 255, see Table 5-5 for meaning

Command: +FBOR Data Bit Order

Description: This parameter controls the mapping between PSTN facsimile data and the DTE-DCE link. There are two choices:

- Direct: The first bit transferred to each byte on the DTE-DCE link is the first bit transferred on the PSTN data carrier.
- Reversed: The last bit transferred of each byte on the DTE-DCE link is the first bit transferred on the PSTN data carrier.

There are two data types to control:

- This command controls Phase C data (T.4 encoded data) transferred during execution of +FDT or +FDR commands.

The following two codes are supported:

- +FBOR=0 or 2 Selects direct bit order for Phase C data.
- +FBOR=1 or 3 Selects reversed bit order for Phase C data.

This parameter does not affect the bit order of control characters generated by the DCE.

Write syntax: +FBOR=<value>

Valid values: 0, 1, 2, or 3

Default value: 0

Command: +FAA Answer Parameter

Description: Fax adaptive answer operates only when +FCLASS=0. Class 2 adaptive answer is implemented as follows:

First, a data mode handshake is attempted. If the DCE has been configured for automode detection (using the +MS command), the DCE may try several protocols before terminating attempts to make a data mode connection. This can take as long as 6-8 seconds.

If the data mode connection attempt fails, a facsimile Class 2 connection is assumed. When a connection is made as a result of the adaptive answer, the DCE issues the DATA or FAX result code before the CONNECT or +FCON message to inform the DTE of the connection type. After making a Class 2 connection, the DCE stays on-line rather than going into the command mode as with a Class 1 connection.

Write syntax: +FAA=<value>

Valid values: 0 or 1

Default value: 0

- +FAA=0 Constrains the DCE to answer as set by +FCLASS.
- +FAA=1 Indicates that the DCE can answer and automatically determine whether to answer as a Class 2 facsimile DCE or as a data modem. If the DCE automatically switches, it modifies FCLASS appropriately.

Command: +FBUF? Buffer Size

Description: The +FBUF parameter allows the DTE to determine the characteristics of the DCE's data buffer. Data buffers are used for flow control. Use of the reported values allow the DTE to transfer data without provoking XOFF.

Read syntax: +FBUF?

DCE response syntax: <bs>, <xoft>, <xont>, <bc>

where:

- <bs> = total buffer size
- <xoft> = XOFF threshold
- <xont> = XON threshold
- <bc> = current buffer byte count

Example: +FBUF?
512, 506, 500, 0

Example Sessions

Table 5-6 and Table 5-7 show the typical command and responses for sending and receiving two pages, respectively.

Table 5-6. Send Two Pages, 1-D, No Errors

DTE Command	DCE Response	Local DTE Action	Remote Station Action
AT+CLASS=2	OK	Set Class 2	X
AT+FLID="<local ID>"	OK	Set local ID	
AT<dial string>	+FCON [+FCSI:"<csi>"] +FDIS: <dis codes> OK	Off-hook, dial Send CNG Detect flags [Get CSI] Get DIS	Answer, Send [CED] V.21 flags [CSI] DIS
AT+FDT	+FDCS:<DCS codes> CONNECT <XON>	[Send TSI] Send DCS Send TCF Get CFR Send carrier	[Get TSI] Get DCS Get TCF Send CFR Receive carrier
<1st page data>		Send page data	Receive page data
<DLE><ETX>	OK		
AT+FET=0	+FPTS:1 OK	Send RTC Get MPS Get MCF	Get RTC Get MPS Send MCF
AT+FDT	CONNECT <XON>	Send carrier	Receive carrier
<2nd page data>		Send page data	Receive page data
<DLE><ETX>	OK		
AT+FET=2	+FPTS:1 +FHNG:0 OK	Send RTC Send EOP Get MCF Send DCN Hang up	Get RTC Get EOP Send MCF Get DCN Hang up

Table 5-7. Receive Two Pages, 1-D Data, No Errors

DTE Command	DCE Response	Local DTE Action	Remote Station Action
AT+FCR=1	OK	Enable reception	
AT+FLID="<local ID>"	OK	Set local ID	
	RING	Detect ring	Dials[, Send CNG]
ATA	+FCON [+FTSI:"<tsi>"] +FDCS:<dcs codes> OK	Off-hook Send CED Send CSI Send DIS Detect flags [Get TSI] Get DCS Begin TCF receive	Get CED Get CSI Get DIS Send V.21 flags [Send TSI] Send DCS Start TCF
AT+FDR <DC2>	+FCFR [+FDCS:"<dcs codes>"] CONNECT <page data stream> <DLE><ETX> +FPTS:1, <lc> +FET:0 OK	Accept TCF Send CFR Get page carrier Get page data Detect RTC Get MPS	Finish TCF Get CFR Send pager carrier Send page data Send RTC Drop carrier Send MPS
AT+FDR <DC2>	CONNECT <page data stream> <DLE><ETX> +FPTS:1, <lc> +FET:2 OK	Send MCF Get page carrier Get page data Detect RTC Get EOP	Get MCF Send page carrier Send page data Send RTC Drop carrier Send EOP
AT+FDR	+FHNG:0 OK	Send MCF Get DCN	Get MCF Send DCN

Chapter 6 – Voice Commands

Voice Commands Overview

Voice commands are identified in Table 6-1.

Table 6-1. Voice Commands

Command	Function
Configuration	
+FCLASS	Set Mode
+VCID	Caller ID (CID)
+VNH	Automatic Hang-up control
+FMI?	Manufacturer Identification
+FMM?	Product Identification
+FMR?	Version, Revision, etc.
+FLO	Flow Control
Voice	
+VIP	Voice Initialize All Parameters
+VRX	Start modem Receive (Record)
+VTS	Voice Tone Send (Send single frequency or DTMF)
+VTX	Start modem Transmit (Playback)
+VGR	Voice Gain Receive (Record Gain)
+VGT	Voice Gain Transmit (Playback Volume)
+VIT	Voice Inactivity Timer (DTE/Modem)
+VLS	Analog Source/Destination Selection
+VRA	Ringback Goes Away Timer
+VRN	Ringback Never Appeared Timer
+VSD	Silence Detection (QUIET & SILENCE)
+VSM	Compression Method Selection
+VTD	Beep Tone Duration Timer
+VDR	Distinctive Ring
+VDT	Control Tone Cadence Reporting
+VPR	Select DTE/modem Interface Rate (Turn off autobaud)
Speakerphone	
+VSP	Speakerphone ON/OFF
+VDX	Speakerphone Duplex Mode
+VGM	Microphone Gain
+VGS	Speaker Gain

<DLE> Shielded Event Codes Sent to the DTE

Table 6-2 lists the supported <DLE> shielded codes sent to the DTE in the expression <DLE><code>. The number in parenthesis in the second column corresponds to the T.50 equivalent.

Table 6-2. Supported <DLE> Shielded Codes Sent to the DTE

Code	T.50 Equivalent	Event Report Description
<DLE>	(1/0)	Two contiguous <DLE><DLE> codes indicate a single <DLE> in the data stream
<SUB>	(1/10)	<DLE><DLE> in the data stream
<ETX>	(0/3)	End Data State
X	(5/8)	Packet Header for the “Complex Event Detection Report”
.	(2/14)	Packet Terminator for the “Complex Event Detection Report”
/	(2/15)	Start of DTMF tone shielding
~	(7/15)	DTMF transitions to off
R	(5/2)	Ring
1	(3/1)	DTMF 1
2	(3/2)	DTMF 2
3	(3/3)	DTMF 3
4	(3/4)	DTMF 4
5	(3/5)	DTMF 5
6	(3/6)	DTMF 6
7	(3/7)	DTMF 7
8	(3/8)	DTMF 8
9	(3/9)	DTMF 9
0	(3/0)	DTMF 0
A	(4/1)	Extended Keypad DTMF A
B	(4/2)	Extended Keypad DTMF B
C	(4/3)	Extended Keypad DTMF C
D	(4/4)	Extended Keypad DTMF D
*	(2/10)	Extended Keypad DTMF E
#	(2/3)	Extended Keypad DTMF F
o	(6/15)	Receive Buffer Overrun
c	(6/3)	Facsimile Calling
e	(6/5)	Data Calling
h	(6/8)	Line Current Break (local phone goes on-hook)
H	(4/8)	Line Current Detected (local phone goes off-hook)
s	(7/3)	“Presumed Hangup”(SILENCE) Time-out
q	(7/1)	“Presumed End of Message” (QUIET) Time-out
J	(4/10)	SIT Signal
l	(6/12)	Loop Current Interruption
r	(7/2)	Ringling Tone
b	(6/2)	BUSY
d	(6/4)	DIAL TONE
u	(7/5)	Transmit Buffer Underrun
p	(7/0)	Line voltage increase
P	(5/0)	Line voltage decrease (extension pickup)
a	(6/1)	Facsimile or Data Answer
f	(6/6)	Data Answer

<DLE> Shielded Codes Sent to the Modem (DCE)

Table 6-3 lists the supported <DLE> shielded codes sent to the modem in the expression <DLE><code>. The number in parenthesis in the second column corresponds to the T.50 equivalent.

Table 6-3. Supported <DLE> Shielded Codes Sent to the Modem (DCE)

Code	Code	Simple Action Command Description
<DLE>	(1/0)	Two contiguous <DLE><DLE> codes indicate a single <DLE> in the data stream ("Immediate Command" or "Stream Command")
u	(7/5)	[Action Numbers 0 and 3] Increase the volume or gain by one unit ("Immediate Command")
d	(6/4)	[Action Numbers 1 and 4] Decrease the volume or gain by one unit ("Immediate Command")
p	(7/0)	[Action Number 9] Pause
r	(7/2)	[Action Number 10] Resume
<ETX>	(0/3)	[Action Number 11] End voice Transmit State ("Stream Command")
<CAN>	(1/8)	[Action Number 12] Clear transmit buffer of voice data ("Immediate Command")
!	(2/1)	[Action Number 15] Receive abort ("Immediate Command")

Voice Commands

Command: +VIP Voice Initialize All Parameters
 Description: this command causes the modem to initialize all voice parameters to their default values.
 Syntax: +VIP
 Result Code: OK
 ERROR If not in Voice Mode.

Command: +VRX Start Modem Receive (Record):
 Description: This command causes the modem to start the voice reception process.
 Syntax: +VRX
 Result Codes: OK
 ERROR If not in Voice Mode.

Command: +VTS - Send Voice Tone(s)

Description: This command causes the modem to send DTMF digit or hookflash tones with the duration specified by +VTD, to send DTMF digit or hookflash tones with duration specified by this command, or to send single or dual tone frequencies with duration specified with this command.

Syntax: +VTS=<string>

Defined Values: <string>

The tone generation consists of elements in a list where each element is separated by a comma. Each element can be:

1. A single character which the modem interprets as a DTMF digit (0 - 9, #, *, or A-D) or hookflash (!), with a duration given by the +VTD command.
2. A 3-element string enclosed in square brackets, "[freq1,freq2,dur]", which the modem interprets as a general dual tone and duration selection, or
3. A 2-element string enclosed in curly braces, "{X,dur}", which the modem interprets as a DTMF digit (0 - 9, #, *, or A-D), or hookflash (!) with a duration (dur) different than that given by the +VTD command.

Missing subparameters assume the default value. Unspecified values always default to zero for frequencies, DTMF * for DTMF tones, and +VTD for duration. The omission of commas (and associated subparameters) is valid.

The quantity in the square brackets consists of a 3-element list (freq1,freq2,dur), which can be used to send single or dual tones. The first element is the first frequency (freq1) with range 0 or 200-3000 Hz. The second element is the second frequency (freq2), with range 0 or 200-3000 Hz. The third element is the duration (dur) in 0.01 second intervals with range 0-255 (ASCII units of 10 ms). A list may contain null elements. For example [3000] means that the DCE generates a single tone at 3000 Hz for the default duration, [3000,3300] means that the DCE generates a dual tone at 3000 and 3300 Hz for the default duration, and [,3300] means that the DCE generates a single tone at 3300 Hz for the default duration.

The quantity in the curly braces consists of a 2-element list (X,dur), which can be used to send DTMF tones or hookflash. The first element is the DTMF tone or hookflash (!) character (X), and the second element is the duration (dur) in 0.01 seconds. The characters are of the same set given above. A list may contain null elements. For example, {2} means DTMF tone "2" for the default duration, and {} means silence for the default duration.

The modem will stop the tone generation at the point in the string where the modem detects a parsing error, encounters an invalid frequency range, encounters a <CR>, or encounters a semi-colon.

Reporting Supported Range of Parameter Values:

Command: +VTS=?

Response: (<freq1> range), (<freq2> range), (<dur> range)

Example: (200-3000),(200-3000),(0-255)

OK

Result Codes:

OK Valid command.

ERROR The <string> command is invalid, or a selected frequency is out of range.

Example 1.

This example illustrates tone generation without using any null elements.

The command example is followed by a description of command execution.

AT+VTS={!,30},1,2,[1000,1300,50],!,{*,6},[800,1300,50],9

1. Hookflash with a duration of 300 ms.
2. Play DTMF 1 with a duration given by the +VTD command.
3. Play DTMF 2 with a duration given by the +VTD command.
4. Play tone pair at 1 000 Hz and 1 300 Hz with a duration of 500 ms.
5. Hookflash with a duration given by the +VTD command.
6. Play DTMF * with a duration of 60 ms.
7. Play tone pair at 800 Hz and 1300 Hz with a duration of 500 ms.
8. Play DTMF 9 with a duration given by the +VTD command.

Example 2.

This example illustrates tone generation using null elements. The command example is followed by a description of command execution.

AT+VTS=1,2,[1000,1300,50],[800],9

1. Play DTMF 1 with a duration given by the +VTD command.
2. Play DTMF 2 with a duration given by the +VTD command.
3. Play tone pair at 1000 Hz and 1300 Hz with a duration of 500 ms.
4. Play tone pair at 800 Hz with a duration given by the +VTD command.
5. Play DTMF 9 with a duration given by the +VTD command.

Example 3.

This example illustrates tone generation using null elements and periods of silence.

The command example is followed by a description of command execution.

AT+VTS=1,[,50],2,[],9

1. Play DTMF 1 with a duration given by the +VTD command.
2. Play silence with a duration of 500 ms.
3. Play DTMF 2 with a duration given by the +VTD command.
4. Play silence with a duration given by the +VTD command.
5. Play DTMF 9 with a duration given by the +VTD command.

Command: +VTX Start Modem Transmit (Playback)

Description:

This command causes the modem to start the voice transmission process.

Syntax:

+VTX

Result Codes:

CONNECT The modem accepts the command.

ERROR The modem is not connected to at least one off-hook telephone line or one non-telephone line.

Command: +VGR Voice Gain Receive (Record Gain)

Description:

This command causes the modem to set the gain for received voice samples.

Syntax:

+VGR=<gain> 0 (only valid number) selects automatic gain control

Reporting Current or Selected Values:

Command: +VGR?

Response: <gain>

Example: 0 For the default setting.

Reporting Supported Range of Parameter Values:

Command: +VGR=?

Response: <gain> range

Example: 0

Result Codes:

OK <gain> = 0.

ERROR Otherwise, or if not in Voice Mode.

Command: +VGT Voice Gain Transmit (Playback Volume)

Description: This command causes the modem to set the volume level.
Syntax: +VGT=<level>
Defined Values: <level> Decimal number corresponding to the volume level.
Reporting Current or Selected Values:
Command: +VGT?
Response: <level>
Example: 128 For the default setting.
Reporting Supported Range of Parameter Values:
Command: +VGT=?
Response: <level> range
Example: 0-255
Result Codes: OK <level> = 0-255.
ERROR Otherwise, or if not in Voice Mode.

Command: +VIT Voice Inactivity Timer (DTE/Modem)

Description: This command sets the modem's initial value for the DTE/modem inactivity timer.
Syntax: +VIT=<timer>
Defined Values: <timer> Decimal number corresponding to the time in units of 1.0 second.
A value of 0 disables the timer.
Reporting Current or Selected Values:
Command: +VIT?
Response: <timer>
Example: 0 For the default setting.
Reporting Supported Range of Parameter Values:
Command: +VIT=?
Response: <timer> range
Example: 0-255
Result Codes: OK <timer> = 0-255.
ERROR Otherwise, or if not in Voice Mode.

Command: +VLS Analog Source/Destination Selection

Description: This command causes the modem to select one or more source/destinations of the analog data.

Syntax: +VLS=<label>

Defined Values: <label> Decimal number corresponding to the selected analog source/destination hardware configuration (see Table 6-5).
 Response: <label>
 Example: 0 For the default setting.

Reporting Supported Range of Parameter Values:
 Command: +VLS=?
 Response: <label>,<devices>,<transmit event>,<receive event>,<idle event>
 Where each event subparameter is a hex number the represents an event bit field of the reporting capabilities of each state. (see Table 6-6):
 <label> Identifies the modem analog source/destination hardware configuration
 <devices> A <string constant> made up of Primitives,
 <xxxx event> <transmit event>, <receive event>, and <idle event>subparameters are the DCE event reporting capabilities for the Voice Transmit State, Voice Receive State, and the Voice Command State, respectively. Each of the event reporting subparameters is a hex number that represents an event bit field. The hex number format is defined in Table 6-6); a one in the bit field indicates that the DCE can report the associated event.
 Each of the possible hardware configurations has its own <label>, ..., <idle event> description line (the above form description shows just one). A <CR><LF> terminates each description line.

Example: AT+VLS=?
 0,"",B0804100,B0804100,B0804100
 1,"T",0B8433C1,0FE431C1,0B8431C1
 2,"L",08800300,0CE00100,08800100
 3,"LT",0B8433C1,0FE431C1,0B8431C1
 4,"S",00800300,04E00100,20800100
 5,"ST",0B8433C1,0FE431C1,0B8431C1
 8,"S1",00800300,04E00100,20800100
 9,"S1T",0B8433C1,0FE431C1,0B8431C1
 11,"M1",00800300,04E00100,20800100
 14,"H",00800300,04E00100,20800100
 18,"M1S",00800300,04E00100,20800100
 19,"M1S1",00800300,04E00100,20800100

Result Codes: OK <label> = 0-5,8-9,11,14,18-19.
 ERROR The <label> value is out of range, or if the modem cannot service the request in the <label> subparameter.

Table 6-5. +VLS Command Options

Label	Primitives	Description	+VTX	+VRX	+VSP=1
0	None	DCE on-hook. Local phone connected to the line.			
1	T	DCE off-hook. DCE connected to the line. Local phone provided with power to detect hook condition.	X	X	
2	L	DCE on-hook. Local phone connected to the DCE.	X	X	
3	LT	DCE off-hook. Local phone connected to the line. DCE connected to the line.	X	X	
4	S	Internal Speaker connected to the DCE. DCE on-hook. Local phone connected to the line.	X		
5	ST	Internal Speaker connected to the line. DCE off-hook. DCE connected to the line. Local phone provided with power to detect hook condition.	X	X	
6	M	Internal Microphone connected to the DCE. DCE on-hook. Local phone connected to the line.		X	
7	MST	Internal Microphone and Internal Speaker connected to the line. DCE off-hook. DCE connected to the line. Local phone provided with power to detect hook condition.			X
8	S1	External Speaker connected to the DCE. DCE on-hook. Local phone connected to the line.	X		

9	S1T	External Speaker connected to the line. DCE off-hook. DCE connected to the line. Local phone provided with power to detect hook condition.	X	X	
10	MS1T	Internal microphone and External Speaker connected to the line. DCE off-hook. DCE connected to the line. Local phone provided with power to detect hook condition.			X
11	M1	External Microphone connected to the DCE. DCE on-hook. Local phone connected to the line.		X	
12	M1ST	External Microphone and Internal Speaker connected to the line. DCE off-hook. DCE connected to the line. Local phone provided with power to detect hook condition.			X
13	M1S1T	External Microphone and External Speaker connected to the line. DCE off-hook. DCE connected to the line. Local phone provided with power to detect hook condition.			X
14	H	External Microphone and Speaker combination (handset or headset) connected to the DCE. DCE on-hook. Local phone connected to the line.	X	X	
15	HT	External Microphone and Speaker combination (handset or headset) connected to the line. DCE off-hook. DCE connected to the line. Local phone provided with power to detect hook condition.	X	X	
16	MS	MS Internal Microphone and Internal Speaker connected to DCE.			
17	M1S	MS1 Internal Microphone and External Speaker connected to DCE.			
18	MS1	External Microphone and Internal Speaker connected to DCE.			
19	M1S1	External Microphone and External Speaker connected to DCE.			
<p>Primitives (Column 2): L Local Phone. T Telephone Line. M Internal Microphone. M1 External Microphone. S Internal Speaker. S1 External Speaker. H External Microphone and Speaker combination (handset or headset). Note: All label options in this table may not be supported by the product; see +VLS command</p>					

Table 6-6. Events Detectable in the Voice Mode per V.253

Event Number	Event Description	Event Reporting
0	Caller Id Report	Message
1	DID Report	Message
2	Distinctive Ringing	Pattern
3	RING	Simple
4	DTMF Received	Simple
5	Receive Buffer Overrun	Simple
6	Facsimile Calling (e.g., 1100 Hz)	Simple
7	Data Calling (e.g., 1300 Hz)	Simple
8	Local Phone On/Off-hook	Simple
9	Presumed Hangup (SILENCE) Time-out	Simple
10	Presumed End of Message (QUIET) Time-out	Simple
11	SIT Signal	Simple, Message
12	Bong Tone	Simple
13	Loop Current Interruption	Simple
14	Loop Current Polarity Reversal	Simple
15	Call Waiting Beep/Interrupt	Simple
16	Distinctive Call Waiting	Simple
18	Ringing Tone	Simple
19	BUSY	Simple
20	DIAL TONE	Simple
21	Reorder/Fast Busy	Simple
22	V.21 Channel 2 7E flags	Simple
23	Transmit Buffer Underrun	Simple
24	Extension Phone On/Off-hook	Simple
25	Facsimile or Data Answer (e.g., 2100 Hz)	Simple
26	Data Answer (e.g., 2225 Hz)	Simple
27	Voice Detect	Simple
29	Stuttered Dial tone	Simple (note 1)
30	Invalid Voice Data Format	Simple
31	Lost Data Detected Event	Simple
32	Facsimile Answer	Simple

Legend:

This table lists events without any regard as to whether the DCE reporting of the event is optional or mandatory, and without assigning a DCE reporting mechanism.

The first column lists the event number assignment for each event. The event number also serves another purpose; each number is a bit position in a bit field. Event number 0 is the most significant bit of the left most hex number in a hex representation (V.253 defines a total of eight hex digits). The final bit in the bit field occupies the least significant bit position of the right-most hex number. The bit representations of the event numbers are used in the +VLS= command.

The third column lists whether a single character is enough to report the event, or if the DCE must supply a more complicated report. The description Simple indicates a single character response (<DLE> shielded), Message indicates a full text message (<DLE><X> packet), and Pattern indicates a repeating Message.

Notes:

1. The use of complex event reporting for Stuttered Dial tone is for further study.

Command: +VRA Ringback Goes Away Timer

Description: This command sets the length of time the modem will wait between ringbacks during call origination before the modem can assume that the remote station has gone off-hook.

Syntax: +VRA=<interval>

Defined Values: <interval> Decimal number (0-255) specifying the silence interval time in units of 0.10 second between the end of one ring interval and the start of the next ring interval. A value of 0 forces the modem to report the OK result code immediately after the first Ringback. The range is 0.1 to 25.5 seconds for <interval> = 1 to 255.

Reporting Current or Selected Values:
 Command: +VRA?
 Response: <interval>
 Example: 50 (5 seconds) For the default setting.

Reporting Supported Range of Parameter Values:
 Command: +VRA=?
 Response: (<interval> range)
 Example: (0-255) 255 = 25.5 sec

Result Codes: OK <interval> = 0-255
 ERROR Otherwise, or if not in Voice Mode.

Command: +VRN Ringback Never Appeared Timer

Description: This command sets the length of time the modem will wait between ringbacks during call origination before the modem can assume that the remote station has gone off-hook.

Syntax: +VRN=<interval>

Defined Values: <interval> Decimal number specifying the time period, in units of 1.0 second, that the modem will wait for Ringback during call origination. A value of 0 forces the modem to report the OK result code immediately after dialing. The range is 1 to 25 seconds for <interval> = 1 to 25.

Reporting Current or Selected Values:
 Command: +VRN?
 Response: <interval>
 Example: 10 (10 seconds) For the default setting.

Reporting Supported Range of Parameter Values:
 Command: +VRN=?
 Response: (<interval> range)
 Example: (0-25)

Result Codes: OK <interval> = 0-25
 ERROR Otherwise, or if not in Voice Mode.

Command: +VSD Silence Detection (Quiet and Silence)

Description: This command causes the modem to set the silence detection sensitivity and the required period of silence before the modem reports silence detected at the end of a voice receive either with the "Presumed End of Message" (QUIT) or "Presumed Hangup (SILENCE) event reports.

Syntax: +VSD=<sds>,<sdi>

Defined Values: <sds> Decimal number corresponding to the selected parameter.
 0 Use +VSM silence compression setting and algorithm for long-term silence detection (if +VSM is in use) or proprietary silence compression setting and algorithm for long-term silence detection (if +VSM is not in use).
 127 Sets less aggressive long-term silence detection independent of presence or use of silence compression.
 128 Sets nominal long-term silence detection independent of presence or use of silence compression.
 129 Sets more aggressive long-term silence detection independent of presence or use of silence compression.
 <sdi> Decimal number specifying the required period of silence, in units of 0.1 second, before the modem can report silence detected at the end of a voice receive either with the "Presumed End of Message" (QUIT) or "Presumed Hangup (SILENCE) event reports. A value of 0 disables the modem silence detection. The range is 0.1 to 25.5 seconds for <sdi> = 1 to 255.

Reporting Current or Selected Values:

Command: +VSD?
 Response: <sds>,<sdi>
 Example: 0,50 For the default setting.

Reporting Supported Range of Parameter Values:

Command: +VSD=?
 Response: (<sds> range),(<sdi> range)
 Example: (0,127-129),(0-255)

Result Codes:

OK <hook> = 0 or 1.
 ERROR Otherwise, or if not in Voice Mode.

Command: +VSM Compression Method Selection

Description:

This command causes the modem to set the voice compression method, the silence compression sensitivity, and the voice sampling rate.

Syntax:

+VSM=<cml>,<vsr>,<sds>,<sel>

Defined Values:

<cml> Decimal number identifying the compression method.
 <vsr> <range of values> containing the supported range of voice samples per second of the analog signal.
 <scs> <range of values> containing the supported range of sensitivity settings for voice receives.
 <sel> <range of values> containing the supported range of expansion values for voice transmits.

Reporting Current or Selected Values:

Command: +VSM?
 Response: <cml>,<vsr>,<sds>,<sel>
 Example: 1,8000,0,0 For the default setting.

Reporting Supported Range of Parameter Values:

Command: +VSM=?
 Response: <cml>,<cmid>,<bps>,<tm>,<vsr>,<sds>,<sel>
 <cml> Decimal number identifying the compression method (1, 129, 130, 140, or 141).
 <cmid> Alphanumeric string describing the compression method (UNSIGNED PCM, IMA ADPCM, UNSIGNED PCM, 2 Bit ADPCM, or 4 Bit ADPCM).
 <bps> Decimal number defining the average number of bits in the compressed sample not including silence compression (2, 4 or 8).
 <tm> Decimal number (0) reporting the time interval, in units of 0.1 second, between timing marks. A value of 0 reports that timing marks are not supported.
 <vsr> <range of values> containing the supported range of voice samples per second of the analog signal (8000).
 <scs> <range of values> containing the supported range of sensitivity settings for voice receives (0). A 0 indicates not supported.
 <sel> <range of values> containing the supported range of expansion values for voice transmits (0). A 0 indicates not supported.

Example: 1,"UNSIGNED PCM",8,0,8000,0,0
 129,"IMA ADPCM",4,0,8000,0,0
 130,"UNSIGNED PCM",8,0,8000,0,00
 140,"2 Bit ADPCM",2,0,8000,0,0
 141,"4 Bit ADPCM",4,0,8000,0,0

OK

Result Codes:

OK Valid range.
 ERROR Otherwise, or if not in Voice Mode.

Command: +VTD Beep Tone Duration Timer

Description: This command causes the modem to set the default DTMF/tone generation duration.
Syntax: +VTD=<dur>
Defined Values: <dur> Decimal number specifying the default DTMF/tone generation duration in units of 0.01 second. A value of 0 specifies the value entered by the S11 parameter (50-255 ms). The range is 0.01 to 2.55 seconds for <dur> = 1 to 255.

Reporting Current or Selected Values:
Command: +VTD?
Response: <dur>
Example: 100 For the default setting.

Reporting Supported Range of Parameter Values:
Command: +VTD=?
Response: (<dur> range)
Example: (0-255)

Result Codes: OK <dur>= 0-255.
 ERROR Otherwise, or if not in Voice Mode.

Command: +VDR Distinctive Ring

Description: This command causes the modem to enable or disable reporting of the ring cadence information and to control the timing of the RING event code report if ring cadence reporting is enabled.

Syntax: +VDR=<enable>,<report>
Defined Values: <enable> Decimal number corresponding to the selected option.
 0 The modem will not report ring cadence information.
 1 The modem will report ring cadence information as specified for the <report> subparameter.
 <report> Decimal number specifying ring cadence information report when enabled by the <enable> subparameter.
 0 The modem will produce only DROF and DRON messages. The modem will not produce any RING event codes. The modem will report other call progress event codes as normal.
 Other The modem will produce only DROF and DRON messages. The modem will produce a RING event code after <report>/10 seconds after the falling edge of the ring pulse (i.e., after the DRON report).

Reporting Current or Selected Values:
Command: +VDR?
Response: <enable>,<report>
Example: 0,0 For the default setting.

Reporting Supported Range of Parameter Values:
Command: +VDR=?
Response: (<enable> range),(<report>range)
Example: (0,1),(0-6)

Result Codes: OK <enable>,<report> = (0,1),(0-6)
 ERROR Otherwise, or if not in Voice Mode.

Command: +VDT Control Tone Cadence Reporting

Description: This command is included for compatibility only and has no effect other than returning a result code.

This command allows the modem to enable or disable reporting of the control tone cadence information in the frequency band used by the Ringback/Remote Ring, BUSY, and reorder/Fast Busy tones (usually in the 300 to 600 Hz range).

Syntax: +VDT=<enable>,<report>

Defined Values: <enable> Decimal number corresponding to the selected option.

0 The modem will not produce any control tone cadence report.

<report> Decimal number specifying the produced any control tone cadence report when enabled by the <enable> subparameter.

0 The modem will produce only CPOF and CPON messages.

Other Reserved.

Reporting Current or Selected Values :

Command: +VDT?

Response: <enable>,<report>

Example: 0,0 For the default setting.

Reporting Supported Range of Parameter Values:

Command: +VDT=?

Response: (<enable> range),(<report> range)

Example: (0),(0)

Result Codes:

OK <enable>,<report> = (0),(0)

ERROR Otherwise, or if not in Voice Mode.

Command: +VPR Select DTE/Modem Interface Rate (Turn Off Autobaud)

Description: This command selects the DTE/modem interface rate.

Syntax: +VPR=<rate>

Defined Values: <rate>> Decimal number corresponding to the DTE/modem interface rate where 0 = autobaud rate determined by processing the AT command, and 1,2,3,4,8,16,24,48,96 correspond to multipliers of 2400 bps to determine the actual rate:

0 = Autobaud

1 = 2400 bps

2 = 4800 bps

3 = 7200 bps

4 = 9600 bps

8 = 19200 bps

16 = 38400 bps

24 = 57600 bps

48 = 115200 bps

96 = 230400 bps

Reporting Current or Selected Values:

Command: +VPR?

Response: <rate>

Example: 0 For the default setting (Autobaud).

Reporting Supported Range of Parameter Values:

Command: +VPR=?

Response: (<rate> range)

Example: (0,1,2,3,4,8,16,24,48,96)

Result Codes:

OK <rate> = 0,1,2,3,4,8,16,24,48,96.

ERROR Otherwise, or if not in Voice Mode.

Speakerphone Commands

Command: **+VSP** **Speakerphone ON/OFF**

Description: This command turns the speakerphone ON or OFF

Syntax: +VSP=<mode>

Defined Values: <mode> Decimal number corresponding to the selected option.
 0 The speakerphone function is OFF. (Default.)
 1 The speakerphone function is ON.

Reporting Current or Selected Values:
 Command: +VSP?
 Response: <mode>
 Example: 0 For the default setting.

Reporting Supported Range of Parameter Values:
 Command: +VSP=?
 Response: (<mode> range)
 Example: (0,1)

Result Codes: OK <mode> = 0 or 1.
 ERROR Otherwise, or if not in Voice Mode.

Command: **+VDX** **Speakerphone Duplex Mode**

Description: This command selects speakerphone full duplex mode.

Syntax: +VDX=<mode>

Defined Values: <mode> Decimal number corresponding to the selected option.
 1 The speakerphone mode is full duplex.

Reporting Current or Selected Values:
 Command: +VDX?
 Response: <mode>
 Example: 1 For the default setting.

Reporting Supported Range of Parameter Values:
 Command: +VDX=?
 Response: (<mode> range)
 Example: (1)

Result Codes: OK <mode> = 1.
 ERROR Otherwise, or if not in Voice Mode.

Command: **+VGM** **Microphone Gain**

Description: This command causes the modem to set the microphone gain of the speakerphone function.

Syntax: +VGM=<gain>

Defined Values: <gain> Decimal number between 0 and 255 corresponding to the gain.

Reporting Current or Selected Values:
 Command: +VGM?
 Response: <gain>
 Example: 64 For the default setting.

Reporting Supported Range of Parameter Values:
 Command: +VGM=?
 Response: <gain> range
 Example: 0-255

Result Codes: OK <gain> = 0-255.
 ERROR Otherwise, or if not in Voice Mode with speakerphone enabled (+VSP=1).

Command: +VGS Speaker Gain

Description: This command causes the modem to set the speaker gain of the speakerphone function.

Syntax: +VGS=<gain>

Defined Values: <gain> Decimal number between 0 and 255 corresponding to the gain.

Reporting Current or Selected Values:
Command: +VGS?
Response: <gain>
Example: 128 For the default setting.

Reporting Supported Range of Parameter Values:
Command: +VGS=?
Response: <gain> range
Example: 0-255

Result Codes: OK <gain> = 0-255.
ERROR Otherwise, or if not in Voice Mode with speakerphone enabled (+VSP=1).