



Digi International
6400 Flying Cloud Drive
Eden Prairie, MN 55344
(612) 943-9020

Digi GmbH
Domkloster 1
50667 Köln
Germany

Digi Asia Pte Ltd
13-06 Tower 'A'
391A Orchard Road
Ngee Ann City
Singapore 0923

User's Guide and Reference Manual

for the

PortServer/8 and PortServer/16

Intelligent Network Terminal Servers

90028700B

PortServer Default Settings

Serial Parameters: (all ports) 9600 baud, No parity, 8 bits, 1 stop bit, VT100 terminal emulation

Root Login: root

Root Password: dbps

Digi International™, PortServer™, DigiWARE™, RealPort™, and the  Digi logo are trademarks of **Digi International Inc.** All other brand and product names are the trademarks of their respective holders.

© Digi International 1994, 1995
All Rights Reserved

Digi International		Digi GmbH		Digi Asia Pte Ltd	
6400 Flying Cloud Drive Eden Prairie, MN 55344		Domkloster 1 50667 Köln Germany		13-06 Tower 'A' 391A Orchard Road Ngee Ann City Singapore 0923	
Phone	(800) 344-4273 (612) 943-9020	Phone	+49 221 920520	Phone	+65 732 1318
FAX	(612) 943-5398	FAX	+49 221 9205210	FAX	+65 732 1312
BBS	(612) 943-0550	BBS	+49 221 9205211	BBS	+65 292 7163

Information in this document is subject to change without notice and does not represent a commitment on the part of Digi International.

Digi International provides this document "as is," without warranty of any kind, either expressed or implied, including, but not limited to, the implied warranties of fitness or merchantability for a particular purpose. Digi International may make improvements and/or changes in this manual or in the product(s) and/or the program(s) described in this manual at any time.

This product could include technical inaccuracies or typographical errors. Changes are periodically made to the information herein; these changes may be incorporated in new editions of the publication.

RESTRICTED RIGHTS:

For non-U. S. Government use:

These programs are supplied under a license. They may be used, disclosed, and/or copied only as permitted under such license agreement. Any copy must contain the above copyright notice and this restricted rights notice. Use, copying, and/or disclosure of the programs is strictly prohibited unless otherwise provided in the license agreement.

For U.S. Government use:

Use, duplication, or disclosure by the Government is subject to restrictions as set forth in sub-paragraph (c)(1)(ii) of the Rights in Technical Data and Computer Software clause of DFARS 52.227-7013.

Table of Contents

PREFACE	vi
CONVENTIONS USED IN THIS MANUAL.....	vi
<i>Keyboard Entry</i>	vi
<i>Typefaces</i>	vi
ELECTRONIC EMISSION NOTICES.....	vii
<i>Federal Communications Commission (FCC) Statements</i>	vii
<i>Industry Canada Compliance Statements</i>	vii
INTRODUCTION	1
PORTSERVER QUICK START	3
<i>Configuring the PortServer over the Ethernet</i>	5
COMMAND REFERENCE	28
ABBREVIATIONS.....	28
PORTSERVER HELP SCREENS.....	29
PORTSERVER EDITING KEYSTROKES.....	30
PORTSERVER COMMANDS.....	31
ADMIN.....	31
BOOT.....	31
CPCONF.....	32
EXIT.....	33
INFO.....	33
KILL.....	35
NEWPASS.....	36
PING.....	36
QUIT.....	37
SET.....	38
<i>Range</i>	38
<i>Saving to EEPROM</i>	39
<i>altip</i>	40
<i>arp</i>	41
<i>config</i>	42
Booting the PortServer Software with Remote Boot.....	43
<i>flow</i>	44
<i>host</i>	46
<i>keys</i>	47
<i>line</i>	48
<i>logins</i>	49
Character Strings.....	49
<i>ports</i>	51

<i>route</i>	53
<i>terms</i>	54
<i>users</i>	56
SNMP	58
WHO	59
REMOTE ACCESS COMMANDS	60
CLOSE.....	60
MODE.....	60
RLOGIN	61
SEND.....	62
STATUS	62
TELNET	63
APPENDIX.....	64
REALPORT PROTOCOL	65
SIMPLE NETWORK MANAGEMENT PROTOCOL (SNMP).....	66
<i>Configuring the SNMP Agent</i>	66
<i>SNMP Protocol</i>	67
PORTSERVER FRONT PANEL.....	69
<i>SEND (Serial Activity)</i>	69
<i>ETHERNET (Ethernet Activity)</i>	70
PORTSERVER BIOS	71
<i>Power On Self Test (POST) Sequence</i>	71
USER DIAGNOSTICS	73
<i>Video Display Diagnostics</i>	73
<i>Front Panel Display Diagnostics</i>	73
Basic Test Descriptions.....	74
PORTSERVER SECURITY.....	77
RESETTING THE PORTSERVER TO FACTORY DEFAULTS.....	80
DEVICES AND WIRING CONSIDERATIONS	81
<i>Configuring PortServer Ports as Specific Devices</i>	81
SERIAL DEVICE TYPE CHARACTERISTICS TABLE	84
PRINTERS.....	85
<i>Configuring a Printer</i>	85
<i>Connecting a Printer</i>	85
<i>Printing a File</i>	85
MODEMS.....	86
<i>Notes on Configuring Modems</i>	86
<i>Configuring CU and UUCP to dial out without RealPort</i>	87
<i>RTTY Program</i>	89
RJ CONNECTORS.....	91
<i>10 Pin RJ 45 Plugs</i>	92
<i>8 Pin RJ 45 Plugs</i>	93
<i>6 Pin RJ 11 Plugs</i>	94
<i>4 Pin RJ 11 Plugs</i>	95
<i>Digi RJ-45 to DB-25 Cable Legs</i>	96
<i>Connecting Modems</i>	97

Altpin	97
MULTIPLE SESSIONS	98
<i>Switching to another session</i>	99
<i>Closing a session</i>	99
<i>How to use Multiscreen Multisession</i>	99
<i>Configuring Multiscreens</i>	100
PORTSERVER PORT NUMBERS	101
SPECIFICATIONS	102
DIGI SUPPORT SERVICES	103
<i>The Digi Bulletin Board System</i>	103
<i>Internet FTP Server</i>	103
<i>World Wide Web Server</i>	103
<i>DigiFACTs FaxBack Server</i>	103
<i>Information About Your System</i>	104
<i>Technical Support</i>	105
<i>Customer Service</i>	105
RETURN PROCEDURES	105
INDEX	107

Preface

Conventions Used in this Manual

Certain conventions are used in this manual with respect to keyboard entry and typefaces:

Keyboard Entry

- Single keystrokes are enclosed in angle brackets (e.g. <Enter>, <Esc>, etc.)
- Control keys (i.e. keys which are struck while holding down the <Ctrl> key) are shown as single keystrokes. For example, “<Ctrl-A>” means hold down the <Ctrl> key while striking the <A> key. Similarly, “<Alt-A>” means hold down the <Alt> key while striking the <A> key.
- “Arrow keys” refers to the up, down, right and left arrow keys (<↑>, <↓>, <→>, <←>).
- When you are asked to *enter* a command, type the text shown, then press <Enter>.

Typefaces

- Examples of output to your computer screen are shown in `mono-spaced` characters.
- Commands and data that you are to enter via your keyboard are shown in `mono-spaced` characters.
- Variable information within a typed entry is shown in italics. For example, if you are asked to enter `cp file_name path`, type “`cp`”, followed by a space, then the name of the file to be copied, another space, and the directory path to which the file is to be copied.

Electronic Emission Notices

Federal Communications Commission (FCC) Statements

This equipment has been tested and found to comply with the limits for Class A digital devices pursuant to Part 15 of the FCC Rules. These limits are designed to provide reasonable protection against harmful interference when the equipment is operated in a commercial environment. This equipment generates, uses, and can radiate radio frequency energy, and if not installed and used in accordance with the instruction manual, may cause harmful interference to radio communications. Operation of this equipment in a residential area is likely to cause harmful interference, in which case the user will be required to correct the interference at his own expense.

Only devices certified to comply with the limits for a Class A computing device may be attached to this equipment. Operation with noncertified device(s) is likely to result in interference with radio and TV reception.

This equipment is intended for commercial use only and is not suited for operation in Class B environments.

The use of shielded I/O cables is required when connecting this equipment to any and all optional peripheral or host devices. Failure to do so may violate FCC rules.

Industry Canada Compliance Statements

This Class A digital apparatus meets the requirements of the Canadian Interference Causing Equipment Regulations.

Cet appareil numérique de la classe A respecte toutes les exigences du Règlement sur le matériel brouilleur du Canada.

Introduction

The Digi PortServer intelligent terminal server gives you the ability to connect up to 16 RS-232 asynchronous serial devices (such as terminals and printers) to an Ethernet network. Both Twisted Pair (10BaseT) and Thinnet (10base2) cabling standards are supported via the appropriate connectors on the side of the PortServer box.

Description

The PortServer hardware features a 20 MHz 80186 microprocessor and a 83902 16-bit network interface controller. Other features include one megabyte of RAM, 256K of ROM, up to 8k x 8 of EEPROM, and 16c554 UARTs. Self-tests on power-up help ensure reliability. Front-panel LEDs and controls can be used for diagnostic testing and performance checks, monitoring either RS-232 or Ethernet activity.

Operating software is in firmware, but can also be downloaded from a connected server or workstation via TFTP (Trivial File Transfer Protocol), meaning that the PortServer operating system can always have the most current software without changing the firmware.

After the power-up self-tests and loading of the operating software (either from firmware or downloaded), the PortServer software sends login messages to all connected terminals. (Ports set up as printers or modems do not receive login messages; the factory default sets all ports as terminals.)

Operation Overview

When they get the login prompt, users can log in to the PortServer's on-board operating system. Depending upon their privilege level (as defined by the system administrator), commands can now be issued to the PortServer software to change parameters or connect to one of the network systems. The PortServer software allows the system administrator to set up password-protected accounts with various privilege levels to limit certain users or terminals to restricted access to systems on the network.

Besides terminals, PortServer serial ports can be configured as modem ports (incoming, outgoing or bidirectional) or printer ports. These options require knowledge of your host's operating system to get it to "see" the devices connected to the ports. For supported operating systems, Digi's RealPort port control protocol gives powerful control in accessing the remote PortServer ports.

Help

The PortServer software features extensive help functions. From the main command shell (entered after login), entering a question mark ("?") brings up a list of commands and descriptions. Entering a command followed by "?" produces a list of subcommands and their descriptions.

PortServer Highlights

- Sixteen high-speed asynchronous serial ports, each with full modem control and hardware or software flow control.
- Data rates of up to 57,600 bps.
- Multiple PortServer boxes can be attached to the network, limited only by the capacity of the network.
- Full on-board system diagnostics display results on front panel LED indicators, or on a connected terminal.
- LED indicators display RS-232 signal conditions plus input and output flow control status for any port, **or** Ethernet activity.
- Optional remote booting via TFTP allows firmware upgrades without hardware changes.
- Also: Printer support.
Password access security.
Extensive help functions.
Statistics reporting.
Industry standard twisted-pair and thin-net connectors.

PortServer Quick Start

This “**Quick Start**” **Getting Started** section will help you quickly get your PortServer terminal server up and running. Wherever possible, the factory default settings are used. Later, once you have verified that the PortServer can communicate with your network, you can fine-tune the network and terminal parameters for optimum performance.

Plug in the PortServer power supply, and connect the PortServer to the Ethernet

Step 1. Turn off the power switch on the PortServer unit.



Before connecting the PortServer box to the Ethernet network, be sure to turn the power switch on the PortServer off. Also, when connecting peripheral devices to the PortServer connectors, both the peripheral and the PortServer's power switches *must* be turned off. Plugging any electronic device into another device under power can cause damage to one or both of the devices.

Step 2. Connect your network cable to the appropriate connector on the left side of the PortServer. *Be sure to follow your network system's instructions and precautions on connecting devices to the network.*

If you are using a Thinnet (10Base2) cable, plug the cable into the BNC coaxial connector. Make sure the selector switch is in the left-hand position.

If you are using a Twisted Pair (10BaseT) cable, plug the cable into the 10BaseT connector. Make sure the selector switch is in the right-hand position.

Step 3. Make sure the PortServer's power switch is turned off, then plug the transformer's power connector into the DIN connector on the left side of the PortServer's case. Now plug the PortServer's power adapter into a standard AC outlet.

Connect a control terminal to the PortServer

The PortServer is controlled from a terminal (or PC with terminal emulation software) connected to Port 1 on the PortServer's back panel. (Any port can be used, but we will use the convention of Port 1 here.) In some installations, the PortServer can be controlled directly over the Ethernet; see *Configuring the PortServer over the Ethernet* on page 5.

Step 1. Turn the PortServer's power switch OFF.



Plugging any electronic device into another device under power can cause damage to one or both of the devices.

Step 2. Plug your serial terminal into Port 1 on the back of the PortServer box. One cable leg converter (RJ-45 to DB-25) is included with your PortServer. Please note that this Digi cable leg is wired *straight-through*, and that you will need a null modem cable or adapter to connect a terminal if you use the included cable leg.

You probably do not need all ten RS-232 lines for a terminal connection, and may wish to save the "pigtail" connector for other connections. The following diagram shows a simple three-wire cable for connecting a terminal to the PortServer. Usually, serial terminals and printers need only a three-wire connection. The PortServer supports XON/XOFF (software) handshaking, so the only signal lines necessary are Transmitted Data (TxD), Received Data (RxD) and Signal Ground (SG). *Cables must be shielded to remain in compliance with FCC certification requirements, and the shield should be connected to Chassis Ground (GND) at one end of the cable run.*

The DB-25 end of the cable can be plugged directly into most serial terminals without any adapters. The RJ-11 plug fits in the center of the PortServer's RJ-45 jack. (Be *sure* that the plug is centered in the jack!)

Simple 3-Wire Cable

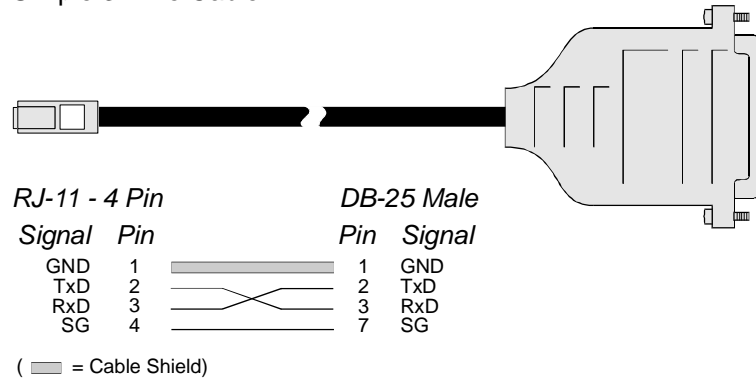

This same configuration can be constructed using 6 pin RJ-11 plugs, or either 8 or 10 pin RJ-45 plugs. See “*RJ Connectors*” on page 91 for the relationship of the various sizes of RJ connectors to the 10 pin RJ-45 jack.

Configuring the PortServer over the Ethernet

If the IP address has not been set, the PortServer will attempt to use RARP (Reverse Address Resolution Protocol) to determine its IP address. If this succeeds, the rest of the PortServer configuration may be completed by connecting to the PortServer using telnet, without connecting a serial terminal.

For this to work, a RARP server must be set up somewhere on the network. Consult your operating system and network software documentation for information on how to do this.

(On many UNIX systems, such information can be found in the manual entry for **rarpd**).

Connect other terminals and peripherals to the PortServer

At this point you may wish to connect other devices (terminals, modems or printers) to the PortServer. If you'd prefer to "play with it" a bit and add other peripherals later, skip this part and go to the next section, *Log in and Configure the PortServer* on page 9.

Terminals

Attach terminals to the other ports as previously described, plugging the RJ-45 or RJ-11 connectors (from the terminals) into the appropriate sockets in the back of the PortServer. All of the ports are equal, and you can configure any port for any device. *Make sure the power is off on the PortServer and the terminals!*

Some terminals require hardware handshaking; most that do use Data Terminal Ready (DTR) for hardware handshaking. Here is a wiring diagram for this method:

Terminal/Printer Cable with DTR Handshaking

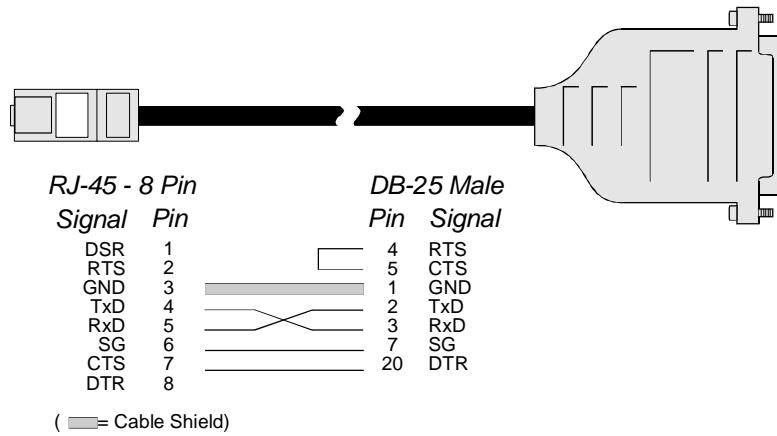

A more inclusive cable (necessary if you are going to set your port device as a host) is a full 10-wire null-modem cable:

Full 10-Wire Null Modem Cable

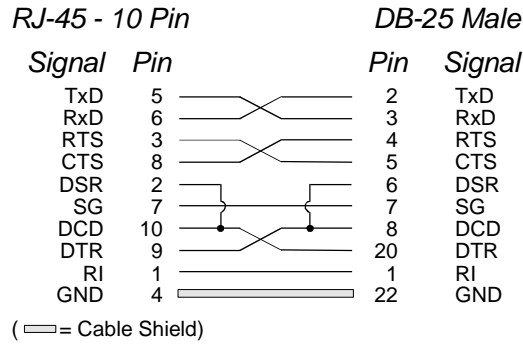
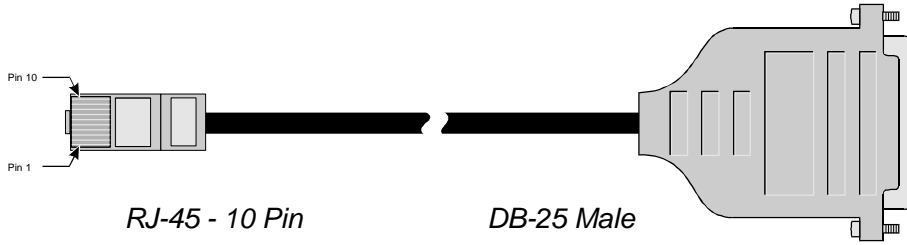

Modems

The easiest way to connect modems is to use Digi's RJ-45 to DB-25 straight-through cables, which offer full 10-pin connections for full modem control. (You may find ten-pin RJ-45 connectors difficult to find in the retail market). Here are the choices and part numbers:

	DB-25 Male	DB-25 Female	DB-9 Male
24 Inch Cables	61020024	61030024	61070024
48 Inch Cables	61020048	61030048	N/A

If you wish to build your own modem cables, follow the diagram below. *Cables must be shielded to remain in compliance with FCC certification requirements, and the shield should be connected to Chassis Ground (GND) at one end of the cable run.*

Full 10-Wire Modem Cable

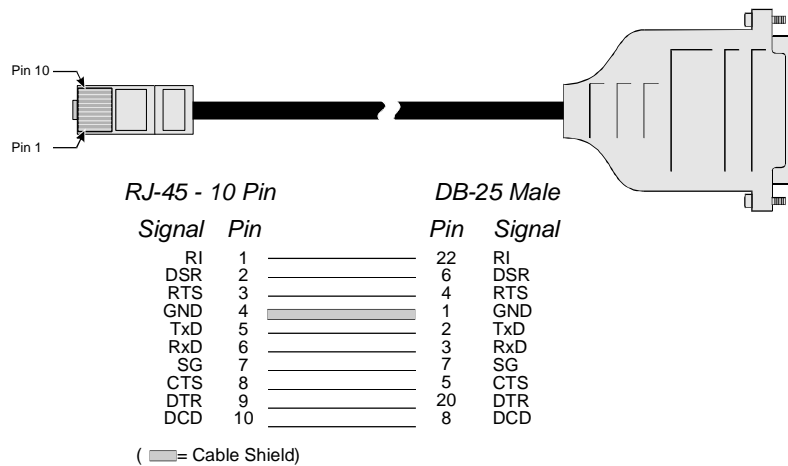

Now connect the modem(s) to the other ports as previously described, plugging the RJ-45 or RJ-11 connectors from the modems into the appropriate sockets in the back of the PortServer. Again, *make sure the power is off on the PortServer and the modems!*

If you want to use 8-pin RJ-45 to DB-25 adapters, a software feature called ALTPIN has been incorporated into the PortServer software to swap the DCD and DSR signals. This makes DCD available on pin 1 of an 8-pin RJ-45 connector. See *Altpin* on page 97.

Printers

Serial printers can have different wiring requirements because of their manufacturer's interpretations of the RS-232 "standard." For those printers that can work with software handshaking (also called "XON/XOFF"), the three-wire hookup for terminals shown on page 5 will work well.

Printers that require hardware handshaking (sometimes referred to as "DTR/DSR") should work with the terminal hardware handshaking wiring scheme shown on page 6. (Some Okidata printers use a control signal on pin 11, called Supervisory Send Data (SSD) instead of DTR. In this case, simply connect CTS on the RJ-45 side to pin 11 of the DB-25, instead of pin 20.)

If your printer manufacturer suggests a different wiring scheme, use it. *Cables must be shielded to remain in compliance with FCC certification requirements, and the shield should be connected to Chassis Ground (GND) at one end of the cable run.*



This same configuration can be constructed using 6 pin RJ-11 plugs, or either 8 or 10 pin RJ-45 plugs. See "RJ Connectors" on page 91 for the relationship of the various sizes of RJ connectors to the 10 pin RJ-45 jack.

Make sure the power is turned off on both the PortServer and the printers, and connect the printers to the other ports as previously described.

Log in and Configure the PortServer

Step 1. Turn on the terminal (or PC running terminal emulation software). Set the terminal parameters to VT-100 emulation, 9600 baud, 8 data, 1 stop, and no parity.

(These are the factory default PortServer settings. While the PortServer can be instructed to change these parameters, the terminal must be set to these default values at first, in order to communicate with the PortServer software to change the parameters!)

Step 2. Turn the PortServer's power switch on.

Step 3. The PortServer firmware's Power On Self Test (POST) sequence will now run automatically, displaying different messages in the 7 segment LED display as it performs different tests. If no errors are detected, the 7 display should end up displaying **AC**, and the ten LEDs will each go on in sequence.

- Step 4.** When **AC** is showing on the PortServer display, press the Return or Enter key on your keyboard; you should get the `login:` prompt. Enter `root`. When asked for the root password, enter `dbps`:

```
login: root
passwd:
#>
```

(Note in this screen dump that the password is not echoed to the screen.) When you see the `#>` prompt, you are logged in.

- Step 5.** Now you need to enter some network configuration information for the PortServer’s network parameters configuration table, using information available from your network administrator (or network documentation). Examples here will have “phony” numbers that you will have to replace with your own information.

IP Address	<p>First, you need to set an IP address for the PortServer unit. Your network administrator can give you an appropriate address to use. Assuming an IP address of 192.83.159.1 (for the sake of this example), enter the following command:</p> <pre>#>set config ip=192.83.159.1 #></pre> <p>(Again, enter the IP Address as assigned by your network administrator, not the example address shown above!)</p>
Node Name	<p>Enter the node name you have assigned for the PortServer. This example uses “termserver”:</p> <pre>#>set config myname=termserver #></pre>
Domain Name	<p>If applicable, enter the name of the domain that the PortServer is part of. The default name is “DOMAIN”; this example uses “arnold.org”:</p> <pre>#>set config domain=arnold.org #></pre>

Domain Server's Name	<p>If you have one, enter the IP address of the IP Name Service machine that will translate names to addresses. This example uses "192.83.159.2":</p> <pre>#>set config nameserv=192.83.159.2 #></pre> <p>Note that if you do not have an IP Name Service machine, you can use the PortServer's <code>Set Host</code> commands to build a table of names and their IP addresses. (See page 46.)</p>
Network Subnet Mask	<p>Set your network subnet mask. (The PortServer's default setting is 255.255.255.0); that's also the mask used in this example:</p> <pre>#>set config submask=255.255.255.0 #></pre>
Gateway Address	<p>If you have a gateway, set its IP address. (The default setting of 255.255.255.255 is used in this example):</p> <pre>#>set config gateway=255.255.255.255 #></pre>

There are other PortServer parameters that can be configured. These are covered individually in the *Command Reference* chapter.

Testing the network connection

You should now be able to establish communications with another network machine. (You will need to know the IP Address of the other machine.) Enter the following `ping` command to test the connection:

```
#>ping 192.83.159.227  
#>
```

(Again, the IP address “192.83.159.227” shown above is for example only. Use an IP address that is valid for your network.)

The PortServer software should respond:

```
192.83.159.227 is alive  
#>
```

If you *do not* see the “It is Alive!” message, check the IP address set for the PortServer, as well as that of the target machine. Check your physical network cable connection. You can also use the PortServer’s front panel to check Ethernet activity—see *PortServer Front Panel* on page 69.

Set up ports for your uses

Your next step would be to configure individual PortServer ports for your own specific uses. This section sets up these example ports:

- A wyse60 terminal on port 2, running at 38400 baud with software flow control
- A printer with hardware flow control on port 3
- A bidirectional modem with hardware flow control on port 4

Security Levels

Root Login is required for setting up ports, as it allows complete access to all PortServer options. The root user can write and save the configurable parameters for any port, and the root user sets up the “regular” logins for other users.



Except for parameter changes to his or her own PortServer port, a “regular” user cannot configure any of the PortServer parameters.

The “root” login is always present, and must always have a password. It is not possible to remove the root user entry, or delete the root password. It is possible to change the root password with “newpass” (see page 36), and it is also possible for you to forget the root password if you change it! (In this unfortunate event, see *Resetting the PortServer to Factory Defaults* on page 80). The factory default root password is dbps.

Root level access is required for setting the ports as shown in these examples.

Also see *PortServer Security* on page 77

Note that all changes made here are by default saved to EEPROM memory. The root user can choose *not* to permanently change settings (see *Saving to EEPROM* on page 39); as a security measure, by default “regular” users *cannot* save parameters permanently.

Terminal Setup Example (Wyse60 terminal on port 2, running at 38400 bps with software flow control)

Step 1. Turn off the power to the terminal and the PortServer, and connect the Wyse terminal to Port 2. Power up again.

Step 2. At the Port 1 control terminal, log in as `root`.

We're still using Port 1, but *any* terminal can be used to make PortServer configuration changes, as long as the user logged in as `root`, or has gained root privileges with the `admin` command (page 31)—which as you'd suspect also requires the root password.

Step 3. Again, the default settings are VT-100 emulation, 9600 baud, 8 data, 1 stop, and no parity. For this example, we will change the Port 2 terminal type to **wyse60**, the baud rate to **38400**, and select software flow control for both incoming and outgoing data.

Setting the terminal type and baud rate will require these Set commands: `set port`, `set flow` and `set line`. The `set` command's `range` parameter will also come into play, to tell the PortServer software that the changes we are making are to Port 2.

Terminal Type	Set the terminal type for Port #2 by typing: <pre>#>set port termttype=wy60 range=2</pre> Note that the terminal type names depend upon the conventions accepted by <i>your network's host operating system</i> ; wyse60 in the above example stands for a Wyse 60 terminal. The <code>range=2</code> parameter tells the PortServer software that this command is to affect Port #2; if <code>range=2</code> had <i>not</i> been added, the port we're connected to (Port #1) would have been changed to Wyse 60.
Baud Rate	Change the baud rate of Port #2 from the default 9600 baud to 38400 by typing: <pre>#>set line baud=38400 range=2</pre>

Flow Control	<p>While the default port flow control setting is for software flow control, let's set it again just to make sure, by typing:</p> <pre>#>set flow ixon=on range=2 #>set flow ixoff=off range=2</pre> <p>(In the above, <code>set flow ixon=on</code> sets port #2 to use software flow control (typically XON/XOFF) for <i>output</i> data. <code>set flow ixoff=off</code> sets port #2 to turn off software flow control for <i>input</i> data (keyboards shouldn't need flow control).</p> <p>Shorthand: The above two <code>set flow</code> commands could have been set with one line:</p> <pre>#> set flow ixon=on ixoff=off range=2</pre> <p>Almost all commands can also be abbreviated; see <i>Abbreviations</i> on page 28. For clarity, abbreviations will not be used in these examples, and each command will have its own line.</p>
---------------------	---



set commands are discussed in detail on page 38.

Printer Setup Example (Printer with hardware flow control on port 3)

- Step 1.** Turn off the power to the printer and the PortServer, and connect the printer, wired as discussed on page 9, then power up again.
- Step 2.** At the control terminal, log in as `root`.
- Step 3.** The default settings when defining a port for printing are 9600 baud, 8 data, 1 stop, and no parity. For this example, those will be fine, but we will need to set the flow control.

Setting the port definition to **printer** and setting the flow control to DTR/CTS (“hardware”) will require these Set commands: `set port` and `set flow`. The `set` command's `range` parameter will also come into play, to tell the PortServer software that the changes we are making are to Port 3.

<p>Define Port as Printer</p>	<p>Set Port #3 to be a Printer port by typing:</p> <pre>#>set port dev=prn range=3</pre> <p>Note that you did not have to set the port to be a terminal in the previous example, because they all default to terminal as shipped. To change Port #3 <i>back</i> to a terminal someday, you would type “set port dev=term range=3.”</p> <p>Again, the range=3 parameter tells the PortServer software that this command is to affect Port #3; if range=3 had <i>not</i> been added, the port we are connected to (Port #1) would have been changed to a printer type—effectively ending our session here until we logged in on <i>another</i> terminal to change it back!</p>
<p>Flow Control</p>	<p>Change the flow control for Port #3 to DTR (“hardware”) by typing:</p> <pre>#>set flow cts=on range=3</pre> <p>set flow cts=on sets port #3 to use hardware flow control for <i>output</i> data. (Note how CTS is connected to DTR in the DTR wiring diagram on page 8.) Also note that the printer’s flow control must match the hardware flow control we are setting here.</p> <p>You must also ensure that software flow control is off:</p> <pre>#>set flow ixon=off range=3 #>set flow ixoff=off range=3</pre>



set commands are discussed in detail on page 38.

Please note that using printers through the PortServer terminal server is very operating-system specific and beyond the scope of this Quick Start discussion. See *Printers* on page 85 for more information and application notes.

Modem Setup Example (Bidirectional modem with hardware flow control on port 4)

- Step 1.** Turn off the power to the modem and the PortServer, and connect the modem, wired as discussed on page 8, then power up again.
- Step 2.** At the control terminal, log in as root.
- Step 3.** The default baud rate setting of 9600 baud should be raised *or lowered* to the highest setting that the modem can handle. (Remember that we're talking about the PortServer-to-Modem connection, not the speed at which the modem itself communicates over the telephone lines.) For this example, we will set up the PortServer-to-Modem connection at 2400 baud with hardware flow control.

Setting the port definition to **bidirectional modem** and setting the flow control to RTS/CTS handshaking will require these Set commands: `set port` and `set flow`. The `set` command's `range` parameter will also come into play, to tell the PortServer software that the changes we are making are to Port 4.

Define Port as Bi-directional Modem	<p>Set Port #4 to be a bidirectional modem port by typing:</p> <pre>#>set port dev=mio range=4</pre> <p>Other related choices would have been “<code>set port dev=min</code>” for input-only, and “<code>set port dev=mout</code>” for output only. “<code>set port dev=mio</code>” is for bidirectional connections.</p> <p>Again, the <code>range=4</code> parameter tells the PortServer software that this command is to affect Port #4; if <code>range=4</code> had <i>not</i> been added, the port we're connected to (Port #1) would have been changed to a modem type—effectively ending our session here until we logged back in through the modem!</p>
Baud Rate	<p>Change the baud rate of Port #4 from the default 9600 baud to 2400 by typing:</p> <pre>#>set line baud=2400 range=4</pre>

Flow Control	<p>Change the flow control for Port #4 to RTS/CTS (“hardware”) by typing:</p> <pre>#>set flow rts=on range=4 #>set flow cts=on range=4</pre> <p>(In the above, set flow rts=on sets port #4 to use hardware flow control for <i>input</i> data. set flow cts=on sets port #4 to use hardware flow control for <i>output</i> data.) Also note that the modem must be set (through AT commands or DIP switches) for hardware flow control.</p> <p>You must also ensure that software flow control is off:</p> <pre>#>set flow ixon=off range=4 #>set flow ixoff=off range=4</pre>
---------------------	---



set commands are discussed in detail on page 38.

Please note that setting up and using modems through the PortServer terminal server (or *any* system, for that matter!) can get complicated quickly. See *Modems* on page 86 for more information and application notes.

Set up a new user

A typical next step would be to set up a new user and password. For this example, we will:

- Set up a new user for that Wyse 60 terminal on Port #2; the user's login will be `betty`.
- Give Betty the password `MeBoss`, and require that she give it whenever she logs in. (That is the default, but we will make sure it is in place.) Passwords are case-sensitive, and limited to eight characters in length.
- Change the login prompt from the default `login>` to `MegaCorp>`.
- Set up Betty's secretary Rex as a user *sharing Betty's same terminal connected to Port 2*, with the user name `rex` and the password `wannaB`.
- Set it up so that whenever Rex logs in he is connected directly to the host Corporate, without the opportunity to manipulate the PortServer's command shell.

The PortServer software offers many automatic login and automatic connection options. The one mentioned above is tied to a specific user (`rex`); we could also have tied it to a particular port, but since Betty and Rex share the same terminal, that would have left Betty without access to the PortServer command line. You will want to carefully read (in the *Command Reference* chapter) the entire section on the suite of `set` commands (page 38) to get an idea of all of the PortServer options.

Making the above additions/changes to the PortServer will require the `newpass` command, and these `set` commands: `set host`, `set logins` and `set users`. The `set` command's `range` parameter will also come into play on some commands, to tell the PortServer software that the changes we are making are to ports 1-16. (An eight-port PortServer would use a `range` parameter of 1-8.)

<p>Create New User “Betty”</p>	<p>Create “regular” (as opposed to root) user “Betty” by typing:</p> <pre>#>set users name=betty</pre> <p>The user names are stored in a table of users, viewable by typing “set users” without any other parameters. As you will later find, this way of getting the current PortServer setup information works for all commands. And an easy way of getting help on commands from the PortServer software is to type the command sequence followed by a space and a question mark, like “set users ?” to get a list of the set users options.</p> <p>User names are <i>case sensitive</i>; “Betty” does not mean the same as “betty” or “bEtTy” to the PortServer software.</p> <p>IMPORTANT! <i>Note that for new users, the user password is the same as the username, with the same capitalization. Betty’s password (until she changes it) is the same as her username betty.</i></p>
<p>Require Password</p>	<p>The user password is required by default (set to <code>passwd=on</code>), but we will set it to ON just to make sure. Type:</p> <pre>#>set users name=betty passwd=on</pre> <p>(Yes, we could have done this at the same time as the first step. We had to type in “user name=betty” here so that the Port-Server software knew which user we were talking about.)</p>

<p>Change Betty's Password to "MeBoss"</p>	<p>Passwords are case-sensitive, and limited to eight characters or less. Changing the password can be done either by Betty herself, or by the root user.</p> <p>As root, set the password itself to "MeBoss." Type:</p> <pre>newpass name=betty</pre> <p>The PortServer responds with</p> <pre>current passwd:</pre> <p>Type in "MeBoss"—note that it will not be echoed on the screen. (You will be asked again for the new password, to make sure it was typed correctly.)</p> <p>Betty herself could have logged in (under her old, original password of "betty," and changed the password herself with the newpass command. In that case, she would not have to add "name=betty".</p>
<p>Change Login Prompt to MegaCorp></p>	<p>Change the login prompt for port #2 from the default login> to MegaCorp> by typing:</p> <pre>#>set logins logprompt="MegaCorp>" range=1-16</pre> <p>Note that if you wanted to change login prompt just for port #2, you could have typed <code>range=2</code>; the above range command changed the login prompt for <i>all</i> attached ports.</p> <p>The login prompt length is 11 characters.</p> <p>Also note the quotation marks around "MegaCorp>"; these weren't necessary in this example, but if a space had been included ("Mega Corp>") the quotation marks would have been necessary to let the PortServer software know unambiguously what the new prompt string was.</p>
<p>Create New User "Rex" with Password "wannaB"</p>	<p>This is done in the same way as in the preceding example with Betty. Type:</p> <pre>#>set users name=Rex passwd=on</pre> <p>Change the password (it is now "Rex") as described for Betty.</p>

<p>Have User “Rex” bypass PortServer Command Shell, connect directly to Host “Corporate”</p>	<p>First, we create table entries for the host named “Corporate,” including its IP address (152.83.151.1 is a “phony” name used here for an example). Note that the “ip=” part is not necessary if you have IP name service.</p> <pre>#>set host name=corporate ip=152.83.151.1</pre> <p>(You can inspect the Host table at any time by typing <code>set host</code> with no other parameters.)</p> <p>Next, we configure the PortServer software so that user “Rex” is an <i>auto</i> user, automatically connected to a destination host <i>dest</i>:</p> <pre>#>set users name=rex auto=on #>set users name=rex dest=152.83.151.1 #>set users name=rex dport=23</pre> <p>(Again, 152.83.151.1 is a “phony” IP address; you would use the real IP address for the host named “Corporate.”)</p> <p>Setting <code>dport</code> is necessary to establish a terminal session with the other host. The value 23 means a telnet-type terminal, which will ask Rex to log in again at Corporate. An entry of 513 would specify Rlogin services, and Rex would automatically be logged in <i>as long as his login on “Corporate” is the same user name</i>. Check your operating system documentation for service numbers.</p>
---	--



set commands are discussed in detail on page 38.

Telnet and Multisession

Here is an example of Betty logging in on her newly-configured terminal, logging into her company's Corporate and Engineering hosts via telnet, switching between the two sessions, then logging out.

The PortServer supports up to nine separate login sessions per port. For example, if your company has host computers named Sales, Tech and Production, you can log into all three, and switch among the different sessions and the PortServer command shell by using the *telnet escape key* followed by a number or carriage return.



The default telnet escape key is <Ctrl-]> (Control/Right Square Bracket) and can be changed—see `set keys tesc=value` on page 47.

To temporarily escape from a session to the PortServer command shell (perhaps to start another session), type the telnet escape character followed by a carriage return. You may now start a second session.

To go directly to the first session (bypassing the PortServer shell), type the telnet escape character followed by a 1.

- Type the telnet escape character followed by a 2 to go directly to the second session.
- Type the telnet escape character followed by a carriage return to go to the PortServer command shell.
- From the PortServer command shell, type 1 or 2 *as the first character on a line* to go to the session of that number.
- As a shortcut, you can also toggle between your last two telnet sessions by pressing the telnet escape character followed by “]” (<Ctrl-]>]).

When you switch between sessions, the current session will continue on the next line of your screen *unless* your terminal is capable of multi-screen operation (as entered in `set ports parameter`—see page 51). You may need to hit the enter key between sessions to see your prompt.



AUTO users (like Rex in the previous example) cannot take advantage of multisessions. (The purpose of the Auto option, after all, is to restrict a user or port to a certain host).

<p>Log in as “Betty”</p>	<p>The PortServer is already up and running. Betty turns on her terminal, presses <enter> (if the login prompt is not already showing) and sees:</p> <pre>MegaCorp></pre> <p>She types in <code>Betty</code> and presses ENTER. Next she sees:</p> <pre>passwd:</pre> <p>Betty enters “MEBoss”. The PortServer responds “login invalid. . .” because Betty got the case wrong. She logs in again, and properly enters her new password “MeBoss”.</p>
<p>Start session with Corporate</p>	<p>At the PortServer’s “#>” prompt, Betty starts a session with her company’s host computer called “Corporate” by typing:</p> <pre>#>telnet corporate</pre> <p>Note that she doesn’t have to give an IP address for “Corporate” because her network has IP naming service. If it did not, she could still have entered “telnet corporate” as long as “corporate” and its IP address had been entered in the PortServer’s host table, as described in “Set Host” on page 46. (The syntax for the telnet command is <code>telnet hostname hostip [tcp port#]</code>; that extra port # parameter is not applicable here, but will be used in the next example.)</p> <p>Betty logs in to Corporate using her login and password as set up on that host.</p>
<p>Start new session with Engineering</p>	<p>Betty is now logged into Corporate through the PortServer. She exits the Corporate login and goes back to the PortServer’s command shell by typing the Telnet Escape sequence, which by default is <Ctrl]> (press the Control key and the right square bracket keys at the same time) then pressing Return.</p> <p>Back at the PortServer’s “#>” prompt, Betty starts a session with her company’s host computer called “Engineering” by typing:</p> <pre>#>telnet engineering</pre> <p>Again, she logs into the Engineering host using her login and password as set up on that host.</p>

<p>Switch between sessions</p>	<p>Betty's session with Corporate is session #1, and her session with Engineering is session #2. From her Engineering session, she can switch to Corporate by typing <Ctrl-]> 1 (the telnet escape character <Ctrl-]> followed by the number 1).</p> <p>From her session on Corporate, she can switch to the Engineering session by typing <Ctrl-]> 2, or switch back and forth between the two sessions by pressing <Ctrl-]>].</p> <p>From <i>either</i> session, Betty can go back to the PortServer's command shell by typing the Telnet Escape sequence <Ctrl]> and then pressing Return. Once in the PortServer's command shell, Betty can start other sessions (up to nine), or perform other operations. From the command shell, she can go to either session #1 (Corporate) or session #2 (Engineering) by typing the numbers 1 or 2 respectively as the <i>first</i> character on a line.</p>
<p>Log out of Corporate</p>	<p>Betty now switches back to her Corporate session (using one of the methods just described), and logs out of that session in the way required by the host.</p> <p>She then closes the telnet session and returns to the PortServer command shell with the command:</p> <pre>close</pre>
<p>Log out of Engineering</p>	<p>In the same manner, Betty switches to the Engineering session, (which is now session #1 by virtue of the original Corporate session #1 being closed), logs out and closes the telnet session.</p>
<p>Log out of PortServer</p>	<p>Back at the PortServer command shell, Betty exits her session with:</p> <pre>exit</pre> <p>Note that the command <code>quit</code> works the same as <code>exit</code>. The <code>exit</code> (or <code>quit</code>) command closes all active telnet or rlogin sessions before exiting.</p>



More information about multiple sessions and configuring Multiscreens is in the appendix *Multiple Sessions* on page 98.

Telnet and modems

In a previous part of this getting-started example, we installed a modem on Port #4, with DTR (“hardware”) handshaking and configured for bidirectional (incoming and outgoing calls) use. Here, Betty will telnet to that modem (from her Port #2 terminal to the modem on Port #4), use “AT” type modem commands to set a fixed DTE interface and 2400 baud, then call an information service.



The PortServer cannot switch the serial line baud rate depending on the kind of connection made, so you should configure the modem to lock the serial line speed at the highest baud rate the modem will go. (See your modem’s documentation.)

The telnet command is used to log into a remote system using the telnet protocol. (In this case, calling from the PortServer Port #2 to Port #4, the PortServer itself is a “remote system!”) Recall that the telnet syntax is `telnet hostname|hostip [tcp port#]`. The *hostname* here is actually the PortServer’s *nodename* that you configured when you first set up the PortServer—see page 10. (In this example, the PortServer’s nodename was set to be **termserver**.) The *tcp port#* parameter comes into play when telnetting to devices on the PortServer.

However, it is not possible to telnet to Port #4 by entering “telnet termserver 4”. By Digi International convention, we add 2000 to the PortServer’s port number to create the tcp port numbers. To reference the modem on port 4, use the value 2004.



See *PortServer Port Numbers* on page 101 for more detail.

Telnet to Modem on Port #4	Betty logs into her terminal on Port #2, then connects to the modem installed on Port #4 with the telnet command: <pre>telnet termserver 2004</pre> Betty is now connected directly to the modem, and can directly enter commands to the modem (like “AT” commands to Hayes or Hayes-compatible modems). This example assumes Betty has a 2400 baud Hayes-compatible modem attached to Port #4.
-----------------------------------	---

<p>Set Modem for Hardware Handshake on Serial Connection</p>	<p>In the modem setup example (page 17), the connection from the PortServer to the modem was set to use RTS/CTS hardware handshaking. Here, Betty tells the modem to use the same, by typing:</p> <pre>AT&K3</pre> <p>(Betty is connected directly to the modem, so there are no command prompts.)</p>
<p>Set Modem Baud Rate</p>	<p>In the modem setup example, the connection from the PortServer to the modem was set at 2400 baud. Now Betty sets the modem to 2400 baud.</p> <p><i>(The exact command depends upon the brand and model of modem; refer to your modem documentation when setting up modem connections.)</i></p>
<p>Call Service</p>	<p>Betty now calls the online information service by telling her modem to dial the telephone number (Hayes “AT” command shown; your modems may be different):</p> <pre>ATDT 123-4567</pre> <p>(The example number “123-4567” above would be replaced by the actual telephone number of the service you are calling.)</p>
<p>Log off</p>	<p>Betty exits the online service, then closes the connection to the modem and logs off her terminal:</p> <pre>close exit</pre>



Also see *Modems* on page 86 for information on configuring modems, and using modems and the PortServer with UNIX-based operating systems.

Command Reference

This Command Reference is divided into these parts:

Abbreviations	(page 28)
PortServer Help Screens	(page 29)
PortServer Editing Keystrokes	(page 30)
PortServer Commands	(page 31)
telnet Commands	(page 60)
rlogin	(page 61)

Abbreviations

All PortServer commands may be abbreviated to their shortest *unique* letters. Therefore the command:

```
set users name=jill
```

can be abbreviated to:

```
set u n=jill
```

You may type an asterisk (“*”) in place of “range=1-*n*” to reference all of the ports on the Port-Server.

PortServer Help Screens

On-line help for the PortServer's command language is available to you through context-sensitive help screens. Help is available by entering a “?” either by itself or after part of a command line. The screen will tell you which parameters are available to complete the command line.

At the PortServer prompt, enter a “?” (question mark) with no other parameters to get the top level help screen:

```
login: root
passwd:
#> ?

  admin      boot      close     cpconf
  exit       info     kill      mode
newpass    ping     quit      rlogin
  send       set      snmp      status
  telnet     who      ?

#>
```

For help on a specific command, type the command name followed by a question mark. The example below asks for help for the command **info**:

```
#> info ?

Displays or clears statistics tables.

syntax: info (table_name)|(table_cmd)

tables:

  network    ip        icmp      tcp
  udp        clear

#> info
```

Note: After you enter a request for help, the PortServer software will print the text before the “?” for you on the next command line, anticipating your next command. For example, after the request for help with `info ?` above, notice how the next command prompt includes the word `info` already typed.

PortServer Editing Keystrokes

The following keystrokes can be used in editing commands sent to the PortServer from a terminal:



Cursor Left (Back)



Cursor Right (Forward)



Erase (delete character to left of cursor)



Delete character under cursor



Delete character to left of cursor. ("H" can be changed to another character with the set keys command.)



When typed as first character on a line, copies the previous line from the command buffer onto the current line



Execute the currently typed command



Interrupt character. ("C" can be changed to another character with the set keys command.)

PortServer Commands

These commands are specific to the PortServer.

admin

Syntax: `admin`

The `admin` command allows you root privileges with the PortServer if you have previously logged in as other than root. You will be asked for the root password.

boot

Syntax: `boot action=reset|eewrite`

The `boot` command is used to reboot the PortServer, and requires root privileges.

If the command is entered as `boot action=reset`, the PortServer is reset using the current parameters stored in memory (as when first powered on).

Use `boot action=eewrite` to reboot the PortServer using the factory default settings stored in ROM. *Note that in this event all user configuration will be lost!*



See page 43 for *Remote Booting* via TFTP (Trivial File Transfer Protocol) of up-graded PortServer software.

cpconf

Syntax: `cpconf tohost | fromhost hostname filename`
`cpconf term`

The `cpconf` (copy configuration) command was added to allow saving and restoring the configuration of the PortServer to a disk file. The format of the save file is a list of the `set` commands needed to set up the PortServer in the current configuration. These commands will be read and acted on by the server (just as if the user had typed them on the command line) when the configuration is restored.

Comment lines are allowed; the “#” character must be the first non-whitespace character on a comment line. Such lines will be ignored by the PortServer command line interface.

There are two ways to store the data:

1. Use a terminal emulator program that can capture text to a file and send the text file back to the PortServer;
2. Store and retrieve the configuration file from a host computer that serves TFTP file requests. The TFTP server option is probably more convenient.

The command `cpconf term` will print the configuration directly to the terminal. To save the configuration using a terminal emulation program, capture the output from the `cpconf term` command into a file. To restore such a saved configuration, simply send the contents of the file to the PortServer command line, which will run all the commands as if they were typed by the user at the command line. If this method is used, it is very important that flow control works between the PortServer and the terminal program.

To save the configuration to a TFTP server, use the command `cpconf tohost hostname filename`. Either a true hostname or an ip address may be used for *hostname*. *Filename* is the name of the file to be written; often this name must be a relative path name. (It depends upon the particular TFTP server.) In many cases the TFTP server may require that the file already exist and that it be world-writable before the TFTP transfer will be allowed.

An example of a way to create such a file on UNIX is:

```
touch /tftpboot/psconfig; chmod 666 /tftpboot/psconfig
```

To restore a configuration saved via TFTP, use the command `cpconf fromhost hostname filename`.

Restoring the configuration takes quite a bit longer than saving it. This is because writing to the EEPROM that stores the PortServer's configuration is a lot slower than reading.

If an attempt is made to change the IP address when restoring over the network, the restoration will fail because the PortServer will ignore any conversation on the old IP address. The save file prints a “#” at the beginning of the `set config ip=x.x.x.x` command, commenting it out to avoid the problem.

For security, it is probably wise to remove world write permissions on the save file once the `cpconf` command has completed, to prevent unauthorized users from changing the file.

```
UNIX: Chmod 444 savefile
```

exit

Syntax: `exit`

The `exit` command terminates the *current* PortServer login session. If you `exit` a session without first closing it, PortServer will automatically do a `close` for you. (See the telnet commands). Note that `quit` works the same as `exit`.

The command `exit` can also be used to give up root privileges temporarily acquired with the `admin` command.

info

Syntax: `info table_name|table_command`

The `info` command is used to either view PortServer network statistics tables or to clear their contents. The information in the tables includes the statistics gathered since the tables were last cleared with `info clear`.

The optional tables that can be viewed with `info` are:

```
network          ip              icmp           tcp            udp
```

There is also a command to clear all of the `info` tables:

```
info clear
```

Root privileges are required for `info clear`.

info *tablename* displays the following information (values shown are arbitrary examples). These are actual screen dumps of a root-level session—note the root prompt (#>):

```
#> info network
Network statistics collected over last 129 minute(s).

UcastPktsRcvd   : 480                UcastPktsTxmt   : 741
BcastPktsRcvd   : 5432               BCastPktsTxmt   : 4
bytes rcvd      : 917683             bytes txmtd      : 48291
pkts rcv err    : 0                  pkts txmt err   : 0
receive intr    : 5912               counter intr     : 0
overflow intr   : 0                  pkts missed     : 0
crc errors      : 0                  frame errors     : 0
buf alloc err   : 0                  local pkts      : 0
ip proto pkts   : 2289               arp proto pkts  : 1792
unknown type    : 1824               broadcast pkts   : 5432
```

```
#> info ip
Network statistics collected over last 129 minute(s).

ipInReceives    : 2294               ipInBcast       : 566
ipInNetBcast    : 1248               ipInSubBcast    : 0
ipInHdrErrors   : 566                ipInAddrErrors  : 0
ipInChkErrors   : 0                  ipInVerErrors   : 0
ipInLenErrors   : 0                  ipInClsErrors   : 566
ipInTypIcmp     : 0                  ipInTypUdp      : 1300
ipInTypTcp      : 428                 ipInTypUnknown  : 0
ipInDelivers    : 1728               ipOutRequests   : 743
ipOut2Wait      : 4                  ipOutNoRoutes   : 0
ipForwDatagram  : 0
```

```
#> info icmp
Network statistics collected over last 129 minute(s).

icmpInmsgs      : 0                  icmpInErrors    : 0
icmpInEchos     : 0                  icmpInAdmMsk    : 0
icmpInAdmMskRp : 0                  icmpInEchoRprs  : 0
icmpInRedirect  : 0                  icmpInDstUnrec  : 0
icmpInSrcQuenc : 0                  icmpInTimeExcd  : 0
icmpInParmProb  : 0                  icmpInTimest    : 0
icmpInTimestRp  : 0                  icmpOutMsgs     : 0
icmpOutEchos    : 0                  icmpOutAdmMsk   : 0
icmpOutAdmMskR : 0                  icmpOutEchoRp   : 0
icmpOutRedirec  : 0                  icmpOutDstUnre  : 0
icmpOutSrcQuen  : 0                  icmpOutTimeExc  : 0
icmpOutParmPro  : 0                  icmpPutTimest   : 0
icmpOutTimestR  : 0
```

```
#> info tcp
Network statistics collected over last 129 minute(s).

tcpInSegs      : 436                tcpInFast      : 365
tcpInErrs     : 0                  tcpInCksErrs  : 0
tcpInTcbErrs  : 0                  tcpInNotOkErrs : 2
tcpInDrpData  : 0                  tcpInDrpOwByte : 0
tcpInUrgBytes : 0                  tcpInNotInSeq  : 0
tcpOutSegs    : 613                tcpOutResets   : 0
tcpOutRetxmts : 0                  tcpActiveOpens : 0
tcpPassiveOpen : 5                 tcpAttemptFail : 0
tcpEstabResets : 0                 tcpCurrEstab   : 3
tcpRtoAlgorith : 0                 tcpRtoMin      : 0
tcpRtoMax     : 0                  tcpHolAllocErr : 0
tcpTmrAllocErr : 0                 tcpBarSyn      : 0
tcpBadReset   : 0
```

```
#> info udp
Network statistics collected over last 129 minute(s).

udaInDatagrams : 52                udpInErrors    : 0
udpInNameResp  : 2                  udpInAddrResp  : 4
udpInKme       : 0                  udpInUnknown   : 0
udpOutDatagram : 55                udpNoPorts     : 1248
```

kill

Syntax: `kill tty=tty_number [action=eewrite]`

The `kill` command is used to clear or reset the port named in the `tty_number` parameter. The phrase `action=eewrite` is an optional parameter that should only be used as a last resort, as it rewrites that port's configuration with the factory default settings. If you experience problems with a connection, first try closing the session, shutting the terminal off, etc., before using the `kill tty=tty_number action=eewrite` command.

The `kill` command requires root privileges.

newpass

Syntax: `newpass [user=username]`

Use the `newpass` command to create or change your current password. If you are at the root level, *be very careful not to forget your root password.*

If you supply the optional `name=username`, another user's password can be changed. Root-level privileges are required to change another user's password.

ping

Syntax: `ping hostipaddress|hostname [options . . .]`

The `ping` command is used to request ICMP echo responses from the specified host or network gateway. If the host responds, `ping` will print (hostname) is alive; if no answer, it will print no answer from (hostname). The options are:

<code>fill=<i>any_character</i></code>	Fills the packet with the designated character.
<code>npkts=<i>num_packets</i></code>	The number of packets to send. Allowable values are 1 to 30,000 (default=1). As a special case, enter -1; this will cause ping to send one datagram per second and print one line of output for every response received. In this case, ping will report round trip time and packet loss statistics.
<code>intv=<i>interval</i></code>	Specifies the time in milliseconds between ping requests. Default=1 second (1000 ms).
<code>pksize=<i>num_bytes</i></code>	Used to specify the number of bytes in the packet; the allowable value range is from 18 (the default value) to 1472.

quit

Syntax: `quit`



The `quit` command terminates your *current* login session. If you `quit` a session without first closing it, PortServer will automatically do a `close` for you. (See the `telnet` commands). Note that `exit` works the same as `quit`.

`Quit` can also be used to give up root privileges temporarily acquired with the `admin` command.

set

Syntax: `set tablename [options . . .]`

The `set` command is used to set or display various PortServer system and port parameters. The different tables that can be substituted for *tablename* are:

altip host users	arp route	config terms		The variables in these tables are referenced by their table indexes.
flow logins	keys ports	line		The variables in these tables are referenced by port numbers.

Each of the tables will have their own options, as outlined in the following descriptions.

Range

As a part of any of the `set` commands, you have to specify which port or table entry the command is to affect. In the preceding list of tables, the names above the horizontal line are `set` command variables referenced by their table index, while the items below the line may be specified for modification by port number. *If you do not specify a range, the `set` commands in this section will affect only the port you are logged in from.*

Specify the table entry, or a range of table entries, with the `range` option, in one of three formats:

```
set (command) range=singleport#
```

This tells the `set` command that the rest of the command affects the port number *singleport#*. (Type in the rest of the command after the value for *singleport#*.)

```
set (command) range=startport#-endport#
```

This tells the `set` command that the rest of the command affects the port numbers *startport#* through *endport#*. (Type in the rest of the command after the value for *endport#*.)

It is possible combine the preceding two methods, separated by commas:

```
set (command) range=port# ,startport#-endport# ,port#
```

Multiple command options can be included in the same line with a single range option. For example:

```
set line range=1-4 baud=2400 parity=E csize=7 stopb=1
```

will set the serial characteristics of ports 1 through 4 for 2400 baud, even parity, character size of 7 and 1 stop bit. This could also have been entered as:

```
set line range=1-4 baud=2400
set line range=1-4 parity=E
set line range=1-4 csize=7
set line range=1-4 stopb=1
```

Saving to EEPROM

Each set command also has an option to save to the PortServer's EEPROM. If you are logged in as root, save is on by default. If you are not logged in as root, save is off by default. (Changes made by a non-root user are valid only for the duration of the session.)

Non-root users can only set parameters for their individual ports. If non-root users wish to save their parameters in EEPROM, they must use the command `save=on` as part of the port modification commands they use. The System Administrator must also have configured their port with `set logins write=on`. (See *logins write=* on page 49.)

Since by default saves are automatic for root users, a root user making a temporary change to a port should remember to add to the command the directive `save=off`.

altip

Syntax: `set altip [range=range]`
 `set altip ip=ipaddr group=port# | group#`
 `set altip rmip=ipaddress`
 `set altip rmrange range=range`

The altip command allows you to telnet to a port or huntgroup using an IP address (or host name). You must assign an additional IP address to the port or hunt group.

Options are:

group ip range rmip rmrange save

`set altip range=range`

If the `set altip` command is entered with no options, or no options other than a range, the current altip table entries for that range are displayed. (`set altip` with no range prints the entire table.)

`set altip ip=ipaddr group=port# | group#`

This form of the command makes a new entry, or changes an existing entry. If the IP address matches an existing entry, that entry will be modified. Otherwise a new table entry will be created.

The IP address must be on the same network (or subnetwork) as the main IP address of the PortServer. The group may be a port number or a group number. (See `set ports group=` on page 52 for information on how groups of ports are assigned.)

`set altip rmip=ipaddress`

This form of the altip command remove entries from the table by ip address.

`set altip rmrange range=range`

This form of the altip command remove entries from the table by index numbers.

Up to 16 alternate IP address may be assigned.



Also see *PortServer Port Numbers* on page 101.

arp

Syntax: set arp [range=*range*]
 set arp ip=*ipaddr* ether=*etaddr* [tim2liv=*time*]
 set arp range=*range* rmarp=on

This sets or displays the arp (**A**ddress **R**esolution **P**rotocol) table entries. The arp table maps IP addresses to Ethernet addresses. In most cases, this is done automatically by the ARP protocol and manual modification of this table will not be required. Making changes with ARP requires root privileges. The arp options are:

set arp range=*range*

If the set arp command is entered with no options other than a range, the current ARP table entries for that range are displayed. (set arp with no range prints the entire table.)

set arp ip=*ipaddress* ether=*ethernetaddress* [tim2liv=*time*]

The second form of the set arp command is used to add a new entry into the ARP table. Set *ipaddress* to the ip address to be mapped (in the normal nnn.nnn.nnn.nnn format) and set *ethernetaddress* to the six byte Ethernet address that this IP address should be mapped to (such as 08:00:20:05:0b:da).

The optional parameter *tim2liv* can be set to the length of time, in seconds, to keep an entry in the ARP table. If no value is specified, a default of 1200 seconds (20 minutes) is used.

set arp range=*range* rmarp=on

This is used to remove entries from the ARP table. Set *range* equal to the range of table entries to be removed, using the numbers from the Index field when you view the table using set arp.

You may define up to 16 arp table entries.

config

Syntax: `set config option=value`

This sets or displays the network parameters configuration table entries. Options are:

domain	gateway	myname	ip	nameserv
netcx	submask	ether	boothost	bootfile

More than one configuration option can be included in a command.

Note: The `set config` command writes to EEPROM, and informs you of the number of locations found bad and corrected in EEPROM memory. A non-zero number is worrisome only when the number of errors begins to approach 64, the maximum number of entries in the EEPROM patch table. Anyone with more than 40 corrected errors should contact Digi Technical Support for assistance.

“**EP**” appears on the front panel display any time a write to EEPROM is in progress.

`domain=domain_name`
Specifies the domain name.

`gateway=ipaddress`
Sets the IP address of the gateway.

`myname=PortServer's_name`
Sets the node name of the PortServer box.

`ip=ipaddress`
Sets the PortServer's ip address.

`nameserv=ipaddress`
Specifies the name of the domain name server. If an address is not specified, the host's ip address must be entered using the `set host` covered on page 46.

`realport=tcp_port_number`
This is the RealPort TCP port number, which has a default value of 771 here and in the RealPort drivers. If this number must be changed because of conflicts, remember to change it both here and in the RealPort drivers.

`submask=subnet mask`
Used to set the network subnet mask. Default=**255.255.255.0**

`boothost=ip_address_of_host_with_bootfile`

Used to set the IP address of the remote host with any upgraded PortServer software for booting via TFTP (Trivial File Transfer Protocol). *This requires that the host supports TFTP—see the operating system documentation.*

`bootfile=filename_of_bootfile`

Used to set the filename *with complete path* on the remote host of any upgraded PortServer software for booting via TFTP (Trivial File Transfer Protocol). *This requires that the host supports TFTP—see the operating system documentation.* There is no default name.

Booting the PortServer Software with Remote Boot

A feature of the PortServer operating system software is that it can be upgraded without ROM or other hardware changes. Any upgraded software from Digi can be installed on a host on the network that supports TFTP (Trivial File Transfer Protocol).

First, configure the PortServer box for remote boot by using
`set configboothost=ip_address_of_host_with_bootfile`
to specify the ip address of the host with the upgraded software on it.



Next, configure the PortServer for the filename of that software with
`set configbootfile=filename`
(Make sure that filename includes the complete path.)

Reset the PortServer unit by turning its power switch off, then on again. The PortServer firmware will then go through its self-testing, then load its operating system software from the specified host.

TFTP Error Messages

The host with the bootfile may pass back a TFTP error message, which the PortServer will display in the alphanumeric display. This message will be in the form **En**, where *n* can be one of the following:

- 0 Error not defined, see error message (if any)
- 1 File not found
- 2 Access Violation
- 3 Disk Full or allocation exceeded
- 4 Illegal TFTP operation
- 5 Unknown transfer ID
- 6 File already exists
- 7 No such user

If the remote still will not work, push both arrow buttons ( and ) to boot from the ROM, and check that the boothost ip address is correct, and that the bootfile path and name are correct. Also ensure that your system supports TFTP.

To return to automatically booting from ROM, enter:

```
set config boothost=255.255.255.255
```

flow

Syntax: `set flow option=value`

The set flow commands set or display the hardware and software flow control parameters for RS-232 serial ports. `set flow range` is used to specify multiple ports, or one specific port. Options are:

aixon	altpin	cts	dcd	dsr	dtr	itoss
ixany	ixoff	ixon	range	ri	rts	save

Each of the above will have their own options, as outlined in the following descriptions. (More than one option can be included in a command.)

`aixon=on|off`
Use auxiliary flow control characters (defined by set keys `xona=` and set keys `xofa=`) for output flow control. Default=`off`

`altpin=on|off`
Setting Altpin ON switches the function of the DSR and the DCD inputs on the interface connector, so that DCD is available when using an 8-pin RJ-45 connector instead of a 10-pin RJ-45 connector. (See *RJ Connectors* on page 91.)
Default=`off`

`cts=on|off`
Use (or do not use) CTS (Clear To Send) for output flow control. Default=`off`

`dcd=on|off`
Use (or do not use) DCD (Data Carrier Detect) for output flow control. Default=`off`

`dsr=on|off`
Use (or do not use) DSR (Data Set Ready) for output flow control. Default=`off`

`dtr=on|off`
Use (or do not use) DTR (Data Terminal Ready) for input flow control. Default=`off`

`ixoff=on|off`
When ON, use software flow control (typically XON/XOFF) for input data.
Default=`on`

`ixon=on|off`
When ON, use software flow control (typically XON/XOFF) for output data.
Default=`on`

`range=startport#-endport#`
Specify a range of ports to be modified. If not specified, the command will act on the current port. It is important to specify the port or port range when logged into the PortServer remotely.

`ri=on|off`
When ON, use Ring Indicator (RI) for output flow control. Default=`off`

`rts=on|off`
When ON, use RTS (Request To Send) for input flow control. Default=`off`

`save=on|off`
Save or do not save the changes to EEPROM.

host

Syntax:

```
set host [range=range]  
set host name=hostname ip=ipaddress  
set host rmhost=hostname  
set host rmhost=on range=range
```

This sets or displays the host name table, which maps host names to IP addresses. If name service is configured, this table is filled in automatically, and manual modification of this table will probably not be required. Making changes with this command requires root privileges.

Options are:

```
ip name           range           rmhost
```

`set host [range=range]`

If the `set host` command is entered with no options (or just a range), it prints the current host table (or a range of entries from the table).

`set host name=hostname ip=ipaddress`

This form of the `set host` command makes a new entry, or changes an existing entry. Set *hostname* to the name of the host, and set *ipaddress* to the ip address of the host. If the host name already existed in the table, the new ip address will replace the old ip address; otherwise a new table entry will be created for this hostname and address.

`set host rmhost=hostname`

This form of the `set host` command is used for removing entries from the host table. `set host rmhost=hostname` removes the entry that refers to the *hostname*

`set host rmhost=on range=range`

This form of the `set host` command is also used for removing entries from the host table. `set host rmhost=on range=range` is used to remove entries from the host table by index number(s); these can be found in the table listing (by typing `set host` with no options).

You may define up to 16 host table entries.

keys

Syntax: `set keys option=value`

Use keys to define the local key combinations for various functions. The different keys that can be set are:

<code>eof</code>	<code>erase</code>	<code>intr</code>	<code>kill</code>	<code>range</code>	<code>save</code>
<code>tesc</code>	<code>xon</code>	<code>xoff</code>	<code>xona</code>	<code>xoffa</code>	

Each of the preceding will have their own options, as outlined in the following descriptions. Use `set keys range=` to specify a single port or group of ports.

More than one option can be included in a command.



If the character is a control character, the caret character (^) must be used to indicate that the Ctrl key should be held while pressing the key. (For example, <Ctrl-C> must be entered as the two characters ^C.)

`eof=end_of_file_character`. Default=`^D` (<Ctrl-D>)

`erase=erase_character`. Default=`^H` (<Ctrl-H>)

`intr=interrupt_character`. Default=`^C` (<Ctrl-C>)

`kill=kill_character`. Default=`^U` (<Ctrl-U>)

`range=startport#-endport#`
Specify a range of ports to be modified.

`save=on|off`
Save or do not save the changes to EEPROM.

`tesc=value`
Set the telnet escape character (used to break out of telnet sessions either to the PortServer shell or to other telnet sessions). Default=`^]` (Control Right-Bracket)

`xon=value`
Use to set the XON Character you prefer. Default=`^Q` (<Ctrl-Q>)

`xoff=value`
Use to set the XOFF Character you prefer. Default=`^S` (<Ctrl-S>)

xona=value

Use to set the auxiliary XON Character you prefer. Default= \^Q (<Ctrl-Q>)

xoffa=value

Use to set the auxiliary XOFF Character you prefer. Default= \^S (<Ctrl-S>)

line

Syntax: *set line option=value*

Use *line* to view or modify serial line parameters. Use *set line range=* to specify a single port or group of ports. Options are:

<i>baud</i>	<i>break</i>	<i>csize</i>	<i>error</i>	<i>inpck</i>	<i>istrip</i>
<i>onlcr</i>	<i>otab</i>	<i>parity</i>	<i>range</i>	<i>save</i>	<i>stopb</i>

Each of the preceding will have their own options, as outlined in the following descriptions. (More than one option can be included in a command.)

baud=baudrate

Use to set the baud rate for the port. Legal values are:

50	600	3600	19200
110	1200	4800	38400
150	1800	7200	57600
300	2400	9600	

break=ignore|send|escape

Used to ignore (default), or send an escape sequence when a telnet *break* command is seen.

csize=5|6|7|8

Sets the Character size. Can be 5, 6, 7 or 8 bits per character. Default=8

error=ignore|null|parmk|dos

Tells the PortServer software what to do with parity errors. It can ignore the error (default), change the error character to a null, or mark the error with an FF.

inpck=on|off

Turn on or off input parity checking. Default=*off*

istrip=on|off

When ON, strips the high order bit in each byte. Default= *off*

onlcr=on|off

Use to map (ON) or not to map (OFF) NEWLINE characters to CR-NEWLINE on output. Default=off

otab=on|off

Converts output tabs to eight spaces. Default= off

parity=O|E|N

Use to select Odd, Even or No parity. Default=N (no parity).

range=startport#-endport#

Specify a range of ports to be modified.

save=on|off

Save the changes to EEPROM.

stopb=1|2

Use to set the Stop Bits to 1 or 2. Default=1

logins

Syntax: `set logins option=value`

Use this command to activate/deactivate login and password protection, define prompts and startup messages. `set logins range=` is used to specify multiple ports, or one specific port.

Options are:

cmdprompt	logprompt	login	write
passprompt	passwd	range	save
verbose			

Character Strings

Many of the values entered for logins are character strings. To include a space in a character string, enclose the entire string in quotation marks. For example, to change the PortServer login prompt to Enter login:, type:

```
set logins logprompt="Enter login:"
```

Each of the preceding will have their own options, as outlined in the following descriptions. (More than one option can be included in a command.)

`cmdprompt=character_string`
Use to define the PortServer command prompt. Default is `digi>`. (The root prompt of `>#` cannot be changed.)

`logprompt=character_string`
Use to define the login prompt (up to 11 characters). Default is `login:`. Root privileges required.

`login=on|off`
Use to set whether the user is required to log in before using terminal. Default=`on`. Root privileges required. **Important!** `login` must be ON for Auto users.

`write=on|off`
Use to set whether the user (other than root) can save to the EEPROM. Default=`off` (user cannot write to EEPROM). Root privileges required.

`passprompt=character_string`
Use to define the login password prompt. Root privileges required. Default is `passwd:`

`passwd=on|off`
Use to set whether the user is required to give a password before using terminal. Default=`on`

`range=startport#-endport#`
Specify a range of ports to be modified.

`save=on|off`
Save the changes to EEPROM.

`verbose=on|off`
Use to eliminate “connection” messages before the login prompt. (Useful to batch programmers.) Default=`on`

ports

Syntax: `set ports option=value`

Use `set ports` to set or display device configuration parameters. `set ports range` is used to specify multiple ports, or one specific port. Options are:

auto	bin	dest	dev	dport	edelay
group	sess	range	save	termttype	uid

Each of the preceding will have their own options, as outlined in the following descriptions. (More than one option can be included in a command.)

`auto=on|off`

`auto on` is used in conjunction with `uid`, `dest` and `dport`, to set up a *port* so that a user on that port will bypass the PortServer's command shell and automatically connect to the defined *destination*. (Also see `set users name=auto` on page 56, which is similar except that a specified *User* is always connected to the specified *destination*, bypassing the PortServer's command shell, without regard to what port that user is using.) **Important!** `login` must be set to `on` for Auto users—see `set logins login= on` on page 50.

`bin=on|off`

Used in conjunction with `auto` to specify a binary connection. Default=`off`

`dest=IPaddress`

Use to specify the destination for the auto port. (See `set ports auto`).

`dev=value`

Set the port to a device as indicated in *value*. Possible *values* are `term`, `host`, `prn`, `min`, `mout`, `mio`:

<code>term</code>	Set the port to be a terminal.
<code>host</code>	Set the port to mimic a modem for input only.
<code>prn</code>	Set the port to be a printer.
<code>min</code>	Set the port to be a modem for input only.
<code>mout</code>	Set the port to be a modem for output only.
<code>mio</code>	Set the port to be a modem for input and output.



Also see *Devices and Wiring Considerations* on page 81.

`dport=remote_port#`

Use to specify the port number an auto connect port should connect to. (See *set ports auto* on page 51).

- If set to 23, specifies telnet protocol services.
- If set to 513, specifies Rlogin services.
- If set to 0 (the default value), then checks the value of `uid` (below); if `uid` is set to 0, then specifies telnet services. If `uid` has a valid user index #, then specifies rlogin services.

Check your operating system documentation for service numbers.

`edelay=value`

Use to specify a delay time between packets transmitted under continuous data reception. Values from 1 to 100 are valid, where 1 stands for 10 milliseconds delay. (A value of 2 would be 20 milliseconds, a value of 3 would be 30 milliseconds, a value of 100 would be 1000 milliseconds or one second). Do not change unless you are experienced with packet timing processes. Default=1 (10 ms)

`group=group#`

Assign a group number of like devices (output modems, for example) specified by the `range=` value, so that a user can ask for by group number if he or she does not care which particular port they get, but are satisfied with the first open one. *Pick a group number in the range 17-80 to avoid confusion or conflicts with the "regular" port names.* (See *PortServer Port Numbers* on page 101.)

`sess=number_of_sessions`

Use to set the maximum number of sessions any port can run; valid entries are from 1 to 9. Default=4. (There is a limit of 64 total sessions for all ports on the PortServer.)

`range=startport#-endport#`

Specify a range of ports to be modified.

`save=on|off`

Save the changes to EEPROM.

`termtype=terminaltype`

Use to assign a terminal type to the port. The terminal type is used for the multi-screen/multisession feature (see page 98), and is reported to the remote host during telnet negotiations.

`uid=user_index#`

Use to set the user index number (the number of the user as carried in the PortServer's table). View the table by typing `set users`. (See *set ports auto* on page 51.)

route

Syntax: `set route [range=range]`
 `set route net=network_address mask=ipmask gateway=ipaddress`
 `metric=numhops`
 `set route rmroute=on range=range`

`set route` displays, adds entries to, or removes entries from the routing table. Making changes with this command requires root privileges. Options are:

`net` `mask` `gateway` `metric` `range` `rmroute`

`set route [range=range]`

If the `set route` command is entered with no options (or just a range), the current route table (or a range of entries from the table) is displayed.

`set route net=network_address mask=ipmask gateway=ipaddress metric=numhops`

The second form of the command makes a new entry into the routing table. Set *network_address* to the address of the network or host this routing entry should cover. Set *ipmask* to the network / subnetmask for the network this routing entry should cover, or 255.255.255.255 for a route to a single host. Set *ipaddress* to the ip address of the gateway that ip packets covered by this routing entry should be forwarded to. For the metric number, set *numhops* to the number of hops (number of routers) between the local network and the destination.

`set route rmroute=on range=range`

The third form of the command removes entries from the routing table. Set the range using the index numbers listed when the table is printed. (Display the table with `set route`.)

You may define up to 16 route table entries.

terms

```
Syntax:  set terms [range=range]  
         set terms termttype=terminal_type [npages=# of screens]  
         [clrseq=clear_escseq]  
         [swtseq=screen# pageswitch_escseq] ...  
         [save=on|off]  
         set terms rmterm terminal_type  
         set terms rmterm=on range=range
```

This command sets or displays the terminal types, and their associated escape sequences used when switching between sessions. (See *Multiple Sessions* page 98, as well as your terminal's manual.)

Making changes with this command requires root privileges.

More than one option can be included in a command. Options are:

clrseq	npages	range	rmterm	save
swtseq	termttype			

```
set terms [range=range]
```

If `set terms` is entered with no options (or just a range), the current terminal table is displayed.

```
set terms termttype=terminal_type [npages=# of screens] [clrseq=clear_escseq]  
         [swtseq=screen# pageswitch_escseq] ...  
         [save=on|off]
```

This form of the `set terms` command makes a new terminal table entry, or changes an existing entry. Set *terminal_type* to the name of the terminal type; this name should match the name used for the *termttype* in the `set port` command (page 51), and must also match the name used by the hosts on your network for this type of terminal. If *termttype* matches an existing entry, that entry will be modified by this command; otherwise a new table entry will be created.

Use *npages*= to set # of *screens* to the number of pages of screen memory that the terminal has. Use *clrseq*=*clear_escseq* to set the escape sequence that will clear the terminal's current screen. *swtseq* is the escape sequence that will switch your terminal to the different screen pages; you need to supply one *swtseq*=*screen# switch_escseq* parameter for *each* terminal page. Set *save*=*off* if you do not want to save the changes.



If the character is a control character, the carat character (^) must be used to indicate that the Ctrl key should be held while pressing the key. (For example, <Ctrl-C> must be entered as the two characters ^C.)

Example:

This example sets up the user's default terminal (since no range is specified) to a Wyse60, supporting three screens with a clear sequence of <Ctrl-[> + (control-left bracket, plus key) and defines keys to switch between the three screens.

```
set terms term=wy60 npages=3 clrseq=[+
set terms term=wy60 swtseq=1^[w0
set terms term=wy60 swtseq=2^[w1
set terms term=wy60 swtseq=3^[w2
```

Note that the parameter `term=wy60` *must* be repeated in each line entered; otherwise the `swtseq` changes would not be made to the `wy60` termtpe.

```
set terms rmterm terminal_type
```

This removes the terminal table entry that refers to the *terminal_type*.

```
set terms rmterm=on range=range
```

This removes entries from the table by the index numbers as shown when the terminal table is listed by entering `set terms`.

users

Syntax:

```
set users [range=range]  
set users name=username [passwd=on|off] [auto=on|off]  
    [dest=IPaddress] [dport=tcp_port#]  
set users rmuser=username  
set users rmuser=on range=range  
set users newname=newusername name=oldusername
```

This command sets or displays the user name table. Making changes with this command requires root privileges. More than one option can be included in a command. Options are:

auto	dport	dest	name	newname	passwd
range	rmuser	save			

```
set users [range=range]
```

If the `set users` command is entered with no options (or just a range), it displays the current users table (or a range of entries from the table).

```
set users name=username [passwd=on|off] [auto=on|off]  
    [dest=IPaddress] [dport=tcp_port#]
```

This form of the `set users` command makes a new user entry, or changes an existing user entry. Set *username* to the name of the user. If the name matches an existing entry, that entry will be modified by this command—otherwise a new table entry will be created. Setting `passwd=on` will require the user to enter a password when logging in; setting `passwd=off` allows the user to log in without a password.

If a new user that requires a password is created, the initial password is the same as the user name.

- If `auto` is set to `off`, the user *username* is presented with the `PortServer` command line after logging in.
- If `auto` is turned on, the user *username* will always be connected to the destination specified by `dest=IPaddress` and `dport=tcp_port#`, completely bypassing the `PortServer` command shell. (*IPaddress* is the IP address of the host that this user should automatically be connected to, and *tcp_port#* is the host TCP port that the connection should be made to: 23 means telnet, 513 means rlogin; the default 0 is mapped to rlogin. (Check your operating system documentation for service numbers.)

- (Also see *set port auto* on page 51, which is similar except that a *port* is set up so that any user on that port will bypass the PortServer's command shell and automatically connect to the defined *destination*.)
- **Important!** `login` must be set to `on` for Auto users—see *set logins login=* on page 50.

`set users newname=newusername name=oldusername`

This is used to change the user name *oldusername* already in the table to the new name *newusername*.

set users rmuser=username

This form of the command is used for removing entries from the users table, and removes the entry that refers to *username*.

set users rmuser=on range=range

This form is used to remove entries from the table by index numbers, which can be found in the table listing by typing `set users` with no other options.

You may define up to 16 user table entries.

End of Set Commands

snmp

Syntax: `snmp [run=off | on] [auth_trap=off | on] [trap_dest=ipaddress]`
`[location=PortServer's location]`

The `snmp` command is used to configure and enable/disable snmp. The snmp community is "public." Snmp sets are not supported.

`snmp run=on|off`

This starts or stops the SNMP daemon. Default is Off.

`snmp auth_trap=on|off`

This configures SNMP to send or ignore authentication traps when an authentication error occurs. Default is Off.

`snmp trap_dest=IP address`

This configures SNMP to send all traps to the IP address given.

`snmp location="location of PortServer"`

This gives SNMP the value of `system.sysLocation`, which is a text string that describes the location of the box in a form meaningful to the user. This parameter is optional. Note that the entry must be surrounded by quotation marks if there are spaces used in the text.

`snmp contact="Person to contact"`

This gives SNMP the value of `system.sysContact`, which is the name of the person responsible for managing the PortServer. This parameter is optional. Note that the entry must be surrounded by quotation marks if there are spaces used in the text.

Entering `snmp` with no options prints out the current configuration.



Also see *SNMP Protocol* on page 67.

who

Syntax: who

The `who` command displays a list of the current users of the PortServer. Information includes each user's name and tty, the number of sessions each user is using, and where each user is connected from and connected to.

The output looks like:

```
#> who
tty username nsess   connected_from   connected_to
 15 root          2      local_tty15     local_shell
```

Remote Access Commands

The commands in this section are remote access related.

close

Syntax: `close`

Closes the current tcp session (the session last escaped from) to reenter the PortServer operating system's command mode.

mode

Syntax: `mode [option=off|flow]`

The mode command is used to display telnet operating parameters.

```
#> mode
tty bin  crmod  crlf  sess  hostname
 15 off  off   off   1     poe
 15 on   off   off   2     ctsi
```

bin Enter `mode bin=on` or `mode bin=off` to turn bin (binary characters, both directions) on or off. Default=`off`

crmod Enter `mode crmod=on` or `mode crmod=off` to turn crmod on or off. This adds line feed characters (010 dec) to and *received* carriage returns (013). *This does not affect any characters you type.* (<CR> becomes <CR><LF>) Default=`off`

crlf Enter `mode crlf=on` or `mode crlf=off` to turn crlf on or off. This adds line feed characters (010 dec) to and *sent* carriage returns (013). *This does not affect any characters you receive.* (<CR> becomes <CR><LF>) Default= `off`

rlogin

The `rlogin` command logs a user into a remote system.

syntax: `rlogin hostipaddr|hostname [options]`

options: `[user=username] [esc=escape_char]`

To avoid entering your password when logging into a remote system, you may put the PortServer's node name in the `.rhosts` file. You may also ask the remote system administrator to make passwords globally unnecessary by entering the PortServer's node name in the remote hosts `/etc/hosts.equiv` file.

Options:

`user=username`

You may specify another *username* for the remote login session; otherwise, the remote username used is the same as your local username.

`esc=escape_character`

You may specify a different escape character for disconnecting from the remote host. Normally you would close an `rlogin` session by typing “<CR> ~ .” (That is three keystrokes: Carriage Return key / Tilde key / period key.) Use `esc=` to change the tilde character (“~”) in this context.



If the character is a control character, the caret character (^) must be used to indicate that the Ctrl key should be held while pressing the key. (For example, <Ctrl-C> must be entered as the two characters ^C.)

Once you are connected via `rlogin`, you can escape back to PortServer command mode by replacing the period in the `rlogin` escape sequence with your telnet escape character, followed by a carriage return. You may also type your telnet escape character followed by a digit to switch to an alternate telnet session.

send

Syntax: `send telnet_special_character`

This command transmits one of the following telnet special characters to the last active telnet session:

ao	abort output	escape	esc character
ayt	are you there?	ga	go ahead
brk	break	ip	interrupt process
ec	erase character	nop	no operation
el	erase line	synch	synchronize process

For example, to send a break signal, type: `send brk`

status

Syntax: `status`

The status command displays information on the current telnet session (if any), including the peer you are connected to, and the current mode. Here's an actual example:

```
#> status
Connection 1: sunny
Escape character is ^].
```

telnet

Syntax: `telnet hostname|hostip [port]`

The telnet command is used to log you into a remote system using telnet protocol. Once you are connected via telnet, you can escape back to PortServer command mode by typing your telnet escape character, followed by a carriage return. You may also type your telnet escape character followed by a digit to switch to an alternate telnet session.



(Also see *Multiple Sessions* on page 98.)

Use the format `telnet nodename port+2000` to telnet to a device on a specific port of the PortServer unit. *Nodename* is the PortServer's node name. By Digi International's convention, 2000 is added to the port number; to reference a device on port 8, you would use the value 2008.



See *PortServer Port Numbers* on page 101 for a more detailed explanation.

Appendix

Appendix Table of Contents

RealPort Protocol	65
Simple Network Management Protocol (SNMP).....	66
PortServer Front Panel	69
PortServer BIOS.....	71
User Diagnostics	73
PortServer Security.....	77
Resetting the PortServer to Factory Defaults	80
Devices and Wiring Considerations.....	81
Serial Device Type Characteristics Table.....	84
Printers	85
Modems	86
RTTY Program	89
RJ Connectors	91
Multiple Sessions	98
Configuring Multi Screens	100
PortServer Port Numbers.....	101
Specifications	102
Digi Support Services.....	103

RealPort Protocol

RealPort is a protocol developed by Digi International that, when used in conjunction with device driver software on a host operating system, allows ports on the PortServer to be used as if they were connected directly to the host system. For instance, one advantage the RealPort protocol has over traditional TCP/IP protocols such as telnet is the host operating system can directly change port parameters, such as baud rate, hardware flow control and software flow control using exactly the same method used to change these settings on a local port. The ports on the PortServer may be split among hosts; one host can use the odd-numbered ports while another is using the even numbered ports. There is even a mechanism in place that allows one host to handle incoming modem calls on a port, while allowing other hosts to place outgoing calls if there is no current incoming call. (This must be supported by the host driver software.)

You must have the correct driver(s) for your host operating system(s) to take advantage of RealPort protocol.

The device type (`set port dev=type`) must be set properly for ports that are going to be used with RealPort protocol. Ports that are to be used with three-wire connections (that do not need modem signals) should have the device type set to `prn`. (However, the RealPort driver will see the actual state of the modem signals regardless of the device type setting.) Ports that are to be used with modems should have the device type set to `mout` if they are to be used exclusively for RealPort connections, or set to `mio` if you want incoming calls to go directly to the PortServer's normal login interface. Other connections that need modem signals should have the device type set to `host`. All of these device types except for `prn` will ensure that RTS and DTR modem signals go low and stay low for at least two seconds between connections, to allow modems and other devices to reset properly.

Device types of `term` or `min` should not be used for RealPort devices.

Simple Network Management Protocol (SNMP)



Also see *SNMP* on page 58.

General Information

The PortServer provides a Simple Network Management Protocol (SNMP) agent. This agent implements the current standard Management Information Base II (MIB-II) as defined in RFC1213. In addition, this agent also supports the Character-based MIB (RFC1316) and the RS232-like MIB (RFC1317).

Configuring the SNMP Agent

The SNMP agent is configured via the `snmp` command. Entering `snmp` with no options, as in:

```
snmp
```

prints out a list of the current SNMP configuration. The result is the following:

```
#> snmp

SNMP Status

SNMP Daemon running: on
Authentication traps being sent: off
Trap destination: 199.99.88.1
sysLocation: Bill's office, #101
sysContact: Bill Jones
```

In this example, the SNMP Daemon is running, so the PortServer will answer SNMP requests from a management station. Authentication traps are not being sent, but the other standard traps are being sent to IP address 199.99.88.1. The values for the System portion of MIB II are set to Bill Jones' name and location. See the SNMP command description on page 58 for information on setting the values.

SNMP Protocol

The SNMP agent in the PortServer supports the Get, GetNext, Set, and Trap messages that are defined in RFC1157. The following is a description of these messages.

- Get : Retrieves the value of a specific object from one of the supported MIBs.
- GetNext : Retrieves the value of the object following a specific object in the MIB list. This allows a management station to traverse or “walk” the MIB variables.
- Set : Modifies the value of a MIB object. The PortServer presently allows a limited number of sets.
- Trap : Asynchronously reports a significant event.

The SNMP community is “public.” SNMP sets are not supported.

Supported SNMP Variables

System MIB

sysDescr
sysObjectID
sysUpTime
sysContact
sysName
sysLocation
sysServices

Interfaces MIB

ifNumber
ifIndex
ifDescr
ifType
ifMtu
ifSpeed
ifPhysAddress
ifAdminStatus
ifOperStatus
ifLastChange
ifInOctets
ifInUcastPkts
ifInNUcastPkts
ifInDiscards
ifInErrors
ifInUnknownProtos
ifOutOctets
ifOutUcastPkts
ifOutNUcastPkts

ifOutDiscards
ifOutErrors
ifOutQLen
ifSpecific

Address Translation MIB

atIfIndex
atPhysAddress
atNetAddress

IP MIB

ipForwarding
ipDefaultTTL
ipInReceives
ipInHdrErrors
ipInAddrErrors
ipForwDatagrams
ipInUnknownProtos
ipInDiscards
ipInDelivers
ipOutRequests
ipOutDiscards
ipOutNoRoutes
ipReasmTimeout
ipReasmReqds
ipReasmOKs
ipReasmFails
ipFragOKs
ipFragFails

ipFragCreates
ipAdEntAddr
ipAdEntIfIndex
ipAdEntNetMask
ipAdEntBcastAddr
ipAdEntReasmMaxSize
ipRouteDest
ipRouteIfIndex
ipRouteMetric1
ipRouteMetric2
ipRouteMetric3
ipRouteMetric4
ipRouteNextHop
ipRouteType
ipRouteProto
ipRouteAge
ipRouteMask
ipRouteMetric5
ipRouteInfo
ipNetToMediaIfIndex
ipNetToMediaPhysAddress
ipNetToMediaNetAddress
ipNetToMediaType
ipRoutingDiscards

ICMP MIB

icmpInMsgs
icmpInErrors

icmpInDestUnreachs
icmpInTimeExcds
icmpInParmProbs
icmpInSrcQuenchs
icmpInRedirects
icmpInEchos
icmpInEchoReps
icmpInTimestamps
icmpInTimestampReps
icmpInAddrMasks
icmpInAddrMaskReps
icmpOutMsgs
icmpOutErrors
icmpOutDestUnreachs
icmpOutTimeExcds
icmpOutParmProbs
icmpOutSrcQuenchs
icmpOutRedirects
icmpOutEchos
icmpOutEchoReps
icmpOutTimestamps
icmpOutTimestampReps
icmpOutAddrMasks
icmpOutAddrMaskReps

TCP MIB

tcpRtoAlgorithm
tcpRtoMin
tcpRtoMax
tcpMaxConn
tcpActiveOpens
tcpPassiveOpens
tcpAttemptFails
tcpEstabResets
tcpCurrEstab
tcpInSegs
tcpOutSegs
tcpRetransSegs
tcpConnState
tcpConnLocalAddress
tcpConnLocalPort
tcpConnRemAddress
tcpConnRemPort
tcpInErrs
tcpOutRsts

UDP MIB

udpInDatagrams
udpNoPorts
udpInErrors
udpOutDatagrams

udpLocalAddress
udpLocalPort

SNMP MIB

snmpInPkts
snmpOutPkts
snmpInBadVersions
snmpInBadCommunityNames
snmpInBadCommunityUses
snmpInASNParseErrs
snmpInTooBig
snmpInNoSuchNames
snmpInBadValues
snmpInReadOnly
snmpInGenErrs
snmpInTotalReqVars
snmpInTotalSetVars
snmpInGetRequests
snmpInGetNexts
snmpInSetRequests
snmpInGetResponses
snmpInTraps
snmpOutTooBig
snmpOutNoSuchNames
snmpOutBadValues
snmpOutGenErrs
snmpOutGetRequests
snmpOutGetNexts
snmpOutSetRequests
snmpOutGetResponses
snmpOutTraps
snmpEnableAuthenTraps

PortServer Front Panel

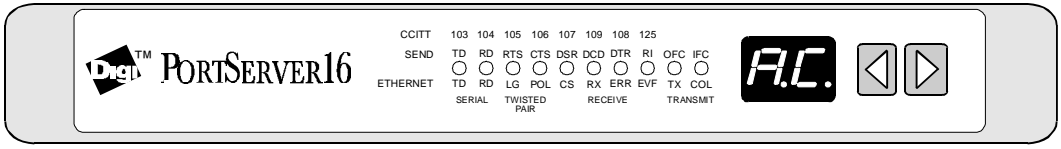

The front panel of the PortServer terminal server has ten LEDs, two seven-segment alphanumeric displays, and two pushbuttons (◀ and ▶).

The pushbuttons are used to:

- ◀ ▶ Select diagnostic tests (see *User Diagnostics* on page 73).
- ◀ ▶ Reset the PortServer to the factory defaults, as described in *Resetting the PortServer to Factory Defaults* on page 80.
- ◀ ▶ Select a port to monitor for RS-232 serial activity.

The two-digit alphanumeric display is used to list error messages and inform the user of test or activity status.

The ten LEDs have different meanings, according to the testing or display mode that the PortServer operating system is in. They are:

SEND (Serial Activity)

You can monitor a port's activity by pressing either pushbutton when AC is shown on the alphanumeric display. The display will then show the port number being monitored; depress the same pushbutton repeatedly until the port you wish to monitor is displayed.

The LED indicators provide RS-232 line status information (similar to a breakout box) and RS-232 flow control information. The ten LEDs then give information related to the labels on the top ("SEND"): TD, RD, RTS, CTS, DSR, DCD, DTR, RI, OFC and IFC. The first eight correspond to activity of that RS-232 signal on the port being monitored. OFC stands for Output is Flow Controlled; IFC stands for Input is Flow Controlled.

ETHERNET (Ethernet Activity)

When **EA** is shown by the alphanumeric display, the row of ten LEDs gives Ethernet information as follows:

“Serial”	TD:	Data has been transmitted on any of the 8 or 16 serial lines.
	RD:	Data has been received on any of the 8 or 16 serial lines.
“Twisted Pair”	LG:	Line Good. (Indicates a good connection to the twisted pair hub box.)
	POL:	Polarity is backwards; while the PortServer hardware fixes this, it indicates that the twisted pair wiring has been installed with the wires transposed.
“Receive”	CS:	Carrier Sense; blinks when the PortServer hardware senses the Ethernet carrier.
	RX:	Blinks when a packet is destined for the PortServer box.
	ERR:	Network error on packet received (CRC, Frame, FIFO overrun, etc.).
	OVF:	Overflow; set when packets come faster than the PortServer hardware can process them.
“Transmit”	TX:	The PortServer hardware is transmitting a packet.
	COL:	Collision on Network (<i>any</i> collision—not necessarily on packets destined to or originated by the PortServer devices).

PortServer BIOS

The PortServer' BIOS can be broken down into three parts: Power On Self Test (POST), Command Mode and user diagnostics.

The POST sequence performs a series of basic tests to ensure that the microprocessor, memory, network interface controller, etc. are functioning properly. Command Mode is used to activate the Ethernet operating system and to switch to the user diagnostics. The user diagnostics are used for more extensive testing of the PortServer hardware.



Power On Self Test (POST) Sequence

The PortServer POST sequence is initiated after the PortServer box is reset or the hardware watchdog timer expires.

The ten LED indicators on the front panel are lit upon successful completion of each of the ten tests. If an error occurs, the LED is not lit. All ten LEDs should be lit for one second upon the completion of the POST sequence, before the firmware begins the optional software download or enters Command Mode.

The following table lists the tests performed during the POST sequence, and the LED that corresponds to each test.

The front panel alphanumeric display shows “**EP**” when saving to EEPROM, “**b1**,” “**b2**,” etc. when booting via TFPT, and “**E1**,” “**E2**” etc. for TFTP errors.

The configuration is cleared by holding both pushbuttons  and  down during powerup until “**EP**” is displayed. (See *Resetting the PortServer to Factory Defaults* on page 80.)

POST Tests	LED
Far jump from FFFF0h to FFC00h. Enable upper memory - EPROM (128K). Set peripheral chip select base address and PCS 0-3. Enable lower memory - DRAM. Enable midrange memory base address - DRAM. Set midrange memory size and PCS 4-6. Processor flag test. Processor register test. Set enhanced mode for the 80186. Perform LED test. Clear all LEDs and display PO. Charge memory cells.	TD
Test 256K DRAM from 00000h to 3FFFFh.	RD

Set temporary stack at 00400h. Data segment now available (00800h). Test 256K DRAM from 40000h to 7FFFFh.	RTS
Test 256K DRAM from 80000h to BFFFFh.	CTS
Test 256K DRAM from C0000h to FFFFFh.	DSR
Set BIOS stack at 3FC00h. Transfer interrupt vectors from EPROM to DRAM. Disable all hardware interrupts. Enable interrupts.	DCD
Check for 16 asynchronous (RS-232) ports.	DTR
Check for NIC (Network Interface Controller).	RI
Board configuration is set. Real time clock is started (Timer 0). NIC and async ports are initialized.	OFC
EEPROM verified. Data from EPROM is moved to DRAM data segment (00800h). Initialization complete.	IFC
Displays “ dE ” for 5 seconds for user diagnostic entry. Displays “ bE ” as BIOS automatically exits to Ethernet operating system.	

Upon completion, the POST sequence will automatically proceed to Command Mode and display “dE” on the 7-segment display. At this point, the operator has five seconds to select user diagnostics. During this five second period, the LEDs display the contents of the status error word. If no errors were detected, the ten LEDs will all be off. Any LEDs remaining on indicate that the corresponding test (see the preceding table) failed.

After the five second delay, the 7-segment display will change to “bE”, indicating that the BIOS has switched control to the Ethernet operating system, and finally to “AC” when the PortServer is ready for operation. (The switch to “bE” is usually too fast to be seen.)

User diagnostics may be selected from Command Mode (during the five second delay). To run the user diagnostics from a terminal, press “V” or “v” on the terminal connected to Port 1 (VT-100, 9600, 8, N, 1). To run the diagnostics from the front panel, press one of the pushbuttons while “dE” is displayed.

User Diagnostics

Video Display Diagnostics

The two modes of the user diagnostics are video display mode and front panel mode. Either mode can be selected at any time before the POST diagnostic tests finish.

- **Front Panel Mode:** Press either “arrow” pushbutton (◀ or ▶). The description of front panel display diagnostics begins on page 73.
- **Video Display Mode:** Enter either a “V” or “v” from a terminal connected to Port 1.



The PortServer video display diagnostics are controlled from a terminal (or PC with terminal emulation software) connected to Port 1. This terminal must be set to 9600 baud, 8 data bits, 1 stop bit, and no parity.

There are eight tests that can be selected. These tests perform diagnostic checks on hardware sections of the PortServer.

If “V” is pressed to enter Video display mode, a startup screen appears. The screen displays test information, and waits for user input.

To start any test, press the appropriate test number. See *Basic Test Descriptions* on page 74 for information on the individual tests.

```

Diagnostics                                     EPROM Version: 0100

      Test Name           Passes   ERRORS

A) - ALL TESTS.
1) - Panel light test .
2) - Memory test.
3) - Memory/DMA test.
4) - Async internal test.
5) - Async external test.
6) - NC/DMA test.
7) - Watchdog timer test.

Enter test selection:

*****

Operator information.



Stop on 1st error - <Y>/<N> = Y
<ESC>ape - Stops the test in progress.
<H>elp - Displays HELP screen.
<D>ump - Dumps 256 bytes of memory.
```

Front Panel Display Diagnostics



Enter Front Panel Mode by pressing either the left or right pushbutton on the front panel during the POST startup tests.

At this time, all of the lights (LEDs) go OFF, the left 7-segment display is blank, and the right 7-segment display reads “1.” The right decimal point blinks at a 1 second rate. At this point, **Test 1 - Panel Light Test** is selected.

The front panel display diagnostics use the 10 LEDs, 14 LED segments, two decimal points, and the two pushbuttons for an operator interface.

To select a test, press the right pushbutton (). The right LED will cycle through the possible test numbers. Once the desired test has been selected, press the left pushbutton () to start the test. The left decimal point will light to indicate the test has started and the appropriate test information will begin updating via the front panel indicators.

The selected test will continue to cycle until an error is detected or until you stop the test by pressing the  pushbutton. Failures accumulate and count up in the 10 digit LED display.

To stop the test with the  pushbutton, press and hold the  button and wait for the left decimal point to go OFF. Then release the  pushbutton and the test will stop.

The left alphanumeric display will display either a “P” or an “F” for pass or fail respectively. The right display will show the test number that was just executed. “P3” indicates that test 3 has passed, while “F3” indicates that the test failed.

Basic Test Descriptions

The following descriptions explain the test philosophy for each functional diagnostic test. The basic test is the same whether it is run from the video display or the front panel display.

Test 1 - Panel Light Test

This test cycles the 10 LEDs ON and OFF and both seven-segment displays in one second intervals. Since the LEDs and seven-segment displays are all write only, the operator must make a visual check of the indicators to ensure that they all cycle correctly. The pushbuttons are read by the test and checked for the non-depressed state (0).

Test 2 - Memory Test

Each pass of this test performs a pattern test and an address tag test to DRAM memory.

The byte pattern is incremented for each pass and is displayed on the front panel LEDs 0-7 (TD-RI). The pattern is written to 32K bytes beginning at address 08000h. The pattern is written again to 32K bytes beginning at address 30000h. The two 32K blocks are compared to determine pass or fail status.

The address tag test writes 32K bytes beginning at address 08000H. Address 08000h equals a 0h, 08001h equals a 1h, etc. This same tag pattern is written 32K times beginning at address 30000h. The two 32K blocks are compared to determine pass or fail status.

The word pattern is incremented for each pass and is displayed on the front panel LEDs 0-7 (TD-RI). The pattern is written to 32K words beginning at address 10000h. The pattern is written again to 32K words beginning at address 20000h. The two 64K blocks are compared to determine pass or fail status.

The address tag test writes 32K words beginning at address 10000h. Address 10000h equals a 0h, 10002h equals a 2h, etc. This same tag pattern is written 32K times beginning at address 20000h. The two 64K blocks are compared to determine pass or fail status.

Test 3 - Memory/DMA Test



This test uses DMA0 to move data from one memory location to another. The byte pattern is incremented for each pass and is displayed on the front panel LEDs 0-7 (TD-RI). The pattern is written to 32K bytes beginning at address 08000h. DMA0 is used to move 32K of data from 08000h to 10000h. When the move is complete, DMA0 interrupts and the two 32K blocks are compared to determine pass or fail status. If the DMA transfer is not completed within two seconds, a timeout error causes the test to fail.

Test 4 - Async Internal Test

This test is used to check out the 16550 async ports. The test puts the UART in loopback mode. The four output signals, DTR, RTS, OUT1, and OUT2 are looped back to the four input signal lines, CTS, DSR, RI and DCD. These signals are checked for high and low conditions. The UARTs are initialized to 9600 baud, 8 data bits, 1 stop bit, and no parity. Data is transmitted and received by the same UART.

Received data is compared to the transmitted data. As each port is being tested, port test results ("Pass/FAIL") are displayed. A failure on one or more ports is considered a test "FAIL."

Test 5 - Built-In UART External Loopback Test

Same as Test 4, but uses external loopback. From the front panel, press the right pushbutton () to select the port to test. The display will cycle from “01” to “16” or highest UART plus “All”. With the port selected, press the left pushbutton () to start the test.

In Test 5 (Async External Test), each port loops back on itself instead of looping back between ports. This requires a test plug made from an RJ-45 connector at one end, with the pins wired as follows:

Output Pins		Input Pins
PIN 3 (RTS)	to	PIN 1 (RI) and PIN 8 (CTS)
PIN 5 (SOUT)	to	PIN 6 (SIN)
PIN 9 (DTR)	to	PIN 2 (DSR) and PIN 10 (DCD)

Test 6 - NIC/DMA Test

This tests the 8390 NIC's ability to transmit, receive, and verify data in three diagnostic modes. To ensure that all test display information and test results are correct, the PortServer unit must be disconnected from the Ethernet network, and the PortServer's Ethernet connector properly terminated.

Test 7 - Watchdog Timer Test

This test checks out the watchdog timer, a hardware feature used to ensure system reliability. The firmware must access PCS 5 within 1.6 seconds or the CPU will reset and jump to the reset vector (0FFFF0h).

It is up to the system to keep accessing PCS 5 to prevent it from resetting. This will force the POST diagnostic sequence to begin. This test allows the timer to expire. Normal test execution causes the user diagnostics to jump to the reset vector and begin the POST diagnostic sequence. The test will fail after three seconds if the timer has not expired.

PortServer Security

The PortServer has four basic security access levels:

Root login

This allows complete access to everything. The root user can write and save any of the configurable parameters for any port.

This login is always present, and must always have a password. *It is not possible to remove the root user entry, or delete the root user password.*

Regular user login

Except for parameter changes to his or her own PortServer port, a regular user *cannot* configure any of the PortServer parameters.

If the “write” option is turned on for a user's port, the user can save those parameters to become the default parameters the next time anyone logs in on that port. If the “write” option is off, only the root user can save port settings.

A regular user can temporarily gain root privileges through the `admin` command *if that user knows the root password.*

This is the most common way of logging into a system. These logins identify a user by name, restrict access by password, and provide access to the PortServer command line after login.

Example: `set users name=george passwd=on`

User login w/o password

This is similar to the most common method, but saves the user the step of entering his or her password. This is mostly useful in small, secure environments that do not have dialup ports.

Example: `set users name=george passwd=off`

Auto-Connect User login

The PortServer supports two types of automatic logins. Auto Connect User (described here) connects a specified user to a specified host *no matter what port or terminal that user logs in from*. Auto Connect Port (described on page 79) connects a specified port to a specified host *no matter what user logs in through it*.

Auto Connect User effectively makes a user name a synonym for a particular connection request. As soon as the user logs in, he or she is connected to the selected system only. An auto-connected user cannot ever escape to the PortServer command line, run multiple sessions, or otherwise connect to a different system other than the one configured for the auto connection.



See *Set Users name=auto* on page 56.

Auto user login

One or more ports (presumably physically secure) may be configured to leave the Unknown user permanently logged in. No user name or password is ever required to gain access to PortServer command mode.

Example: `set login range=1-4 login=off passwd=off`

Important! **Login** must be set to ON for Auto users—see **set logins login=** on page 50.

Auto connect user with password

After logging in, the particular user is connected to a specific system, and cannot access the PortServer command line. If configured with `set users dport=0` or `set users dport=513`, the connection is made using the “rlogin” protocol. If configured with `set users dport=23`, the connection is telnet.

Important! Login must be set to ON for Auto users—see `set logins login=` on page 50.

Rlogin Example:

```
set users name=martha passwd=on dport=0 dest=192.1.2.3 auto=on
```

telnet example:

```
set users name=martha passwd=on dport=23 dest=192.1.2.3 auto=on
```

Auto connect user w/o password

This is the same as “Auto Connect User with Password,” but set up with “passwd=off” added to the command line.

Auto-Connect Port

Auto Connect Port connects a specified port to a specified host *no matter what user logs in through it*. This dedicates a port to be a connection with a specific system only. A user on an auto-connected port can never escape to the PortServer command line, run multiple session, or otherwise connect to a different system.



See *Set Ports Auto* on page 51.

Auto-Connect port causes any port activity (such as a received character on a tty port, or a DCD high transition on a modem port) to automatically connect to a specified system. *No access to the PortServer command line is allowed.*

If configured with `set port dport=23`, the connection uses telnet protocol.

If configured with `set port dport=0 uid=X`, the connection uses the “rlogin” protocol with the username for PortServer user X *if the user index X is valid.*

If configured with `set port dport=513 uid=X`, the connection uses the “rlogin” protocol with the username for PortServer user X.

Rlogin example:

```
set port range=8-9 auto=on dport=0 uid=7 dest=192.1.2.3
```

telnet example:

```
set port range=5-7 auto=on dport=23 dest=192.1.2.3
```

Resetting the PortServer to Factory Defaults



Resetting the PortServer memory to the factory defaults will cause you to lose *all* user settings.

Turn off the PortServer's power switch. Press *and hold* both "arrow" pushbuttons (◀ and ▶) at the same time, and turn on the power switch. Hold the pushbuttons in until the display reads "**EP**" (stands for EEPROM Program).

This will reset the PortServer to boot from the factory ROM. The default Root login will revert to dbps.

Devices and Wiring Considerations

Configuring PortServer Ports as Specific Devices

The Serial Device Type Characteristics Table on page 84 summarizes the device type characteristics described in the following text. You may also wish to refer to *set ports dev=* on page 51 of the *Command Reference* section.

`dev=host` (Computer or other devices)

This is used for connecting another computer via a serial connection; a typical use might be connecting a BBS to the Ethernet through the PortServer. DCD and DTR must be cross-connected between the PortServer and the BBS host. (We will call it a BBS host for this discussion, to avoid confusion with the network's host.)

When the BBS raises DTR to signal that it can receive calls, the PortServer sees DCD go high, and then allows incoming connections (from the Ethernet through the serial connection to the BBS). When an incoming connection happens, the PortServer raises DTR, and the BBS sees DCD go high, and knows that there is a call. (It looks just like a modem answered.)

The BBS can terminate the connection by dropping DTR, which the PortServer sees as DCD going low; the PortServer then terminates the incoming connection. If the incoming connection terminates itself, the PortServer lowers DTR and the BBS sees DCD drop, and knows the connection is terminated. DTR remains low for two seconds and input is flushed to assure a clean disconnect.

This termination control using DTR and DCD is the difference between `dev=host` and `dev=mout` (described later in this section). Both are used for outgoing connections. Host requires that DCD is high before the connection is complete, while `mout` does not.

Wiring required: Full 10-wire Null Modem cable or 8-wire Altpin cable

dev=term

(Terminals)

This is designed for a terminal device. When the device is set to a terminal device, the incoming port ignores DCD. All outgoing connect attempts are refused.

Wiring required: Only TD, RD, and GND connections are needed, making it easy to wire up to a terminal.

dev=prn

(Printers)

The PortServer treats printers as outgoing devices that ignore DCD. Any incoming characters are also ignored, until an outgoing connection is made.

Although the device is called `prn` for printer, it establishes a general purpose output connection that can be used for any other purpose. When a connection is established DTR is raised, otherwise DTR is low. Unlike modem device types, there is no two-second hangup.

Wiring required: Only TD, RD, and GND connections are generally needed, making it easy to wire up to a printer.

dev=min

(Modem In)

This is designed for a modem for incoming communications only. DTR and DCD are supported. In this mode, the PortServer ignores all input until DCD appears. Then it “flushes” all input for 2 seconds to discard messages like RING and CONNECT, before it spawns a login or attempts a connection.

Anytime DCD drops, the PortServer drops DTR, all connections terminate, and the user is logged out.

When a user logs out, or (on an auto-connect port) when the remote system drops the connection, DTR is dropped to hang up the modem. (DTR remains low for 2 seconds to assure a clean modem disconnect, and then input is flushed to discard DISCONNECT messages, etc.)

Wiring required: Modem connections require that TD, RD, DCD, DTR and GND should always be wired in the cable. With modern multi-speed, data compressing modems, you probably also want to wire RTS and CTS for hardware flow control.

dev=mout

(Modem Out)

This is designed for a modem for outgoing communications with full DTR/DCD modem support.

Until an outgoing connection is made, DTR remains low, keeping a modem from answering the telephone. When an outgoing connection succeeds, DTR is raised.

The state of DCD is ignored, except that a high-to-low transition of DCD closes the connection, and drops DTR. DTR then remains low for 2 seconds to assure a clean modem disconnect, and then input is flushed to discard DISCONNECT messages, etc.

Wiring required: Modem connections require that TD, RD, DCD, DTR and GND should always be wired in the cable. With modern multi-speed, data compressing modems, you probably also want to wire RTS and CTS for hardware flow control

dev=mio

(Modem In & Out)

This is designed for a modem used as a bi-directional device (incoming and outgoing) with full DTR/DCD modem support.

When idle, the PortServer leaves DTR high so the modem will answer the telephone.

If DCD goes high when the device is idle, it assumes an incoming connection, and acts like a “dev=min” device until the device goes idle again.

If an outgoing connection succeeds when the device is idle, it switches into outgoing mode and acts as a “dev=mout” device until the connection is dropped. (DTR remains low for 2 seconds to assure a clean modem disconnect, and then input is flushed to discard DISCONNECT messages, etc.)

Wiring required: Modem connections require that TD, RD, DCD, DTR and GND should always be wired in the cable. With modern multi-speed, data compressing modems, you probably also want to wire RTS and CTS for hardware flow control.

Serial Device Type Characteristics Table

This table summarizes the device type characteristics.

Device Type	DTR + RTS when idle	Spawn Login	Remote Connect (telnet, rsh) allowed	Action when DCD drops
term	high	data	no	ignore
prn	low	never	yes	ignore
host	low	never	if DCD	hangup
min	high	DCD raises	no	hangup
mout	low	never	yes	hangup
mio	high	DCD raises	if idle	hangup

Printers

Configuring a Printer

First, you need to define the port that the printer is connected to as a printer device, with the command `set ports dev=prn range=printer port`. (See page 51.) Also see *Devices and Wiring Considerations* on page 81.

Connecting a Printer

See the discussion on connecting peripheral devices on page 6 for a suggested printer wiring diagram, and the discussion under “`dev=prn`” on page 82. For most printers you will also have to configure software or hardware flow control, or the printer will fall behind and data will be lost.

Most printers that use hardware flow control use DTR flow control. Therefore DTR from the printer must be wired to some input on the PortServer (usually CTS or DCD) that can be used for flow control. Some printers use Printer Busy (pin 11) for output flow control.

The type of flow control used is set by the `set flow=` commands, described on page 44.

When setting flow control on the PortServer, **do not** set any flow control from the host you’re printing from.

Printing a File

Telnet example: (printer on port 1)

```
pr myfile | telnet ncx 2001
```

RSH example: (printer on port 1)

```
pr myfile | rsh ncx 1
```

- If you are not getting the proper linefeed after a carriage return, turn on `onlcr` (converts CR to CR-NEWLINE). The command is `set line onlcr=on` (as described on page 49).

- TABS (ASCII 9) can be converted to spaces, with 8 spaces per TAB character. Use `set line otab=on` if you want tabs converted. (See page 49).

Modems

Notes on Configuring Modems

Usually its desirable to configure modems to be bidirectional (`dev=mio`) although if desired they may also be configured to be input only (`dev=min`) or output only (`dev=mout`).

- Be sure to wire TD, RD, DCD, DTR and GND in the modem cable.
- Make sure the modem is configured so DCD goes high when an incoming connection is received. (For Hayes-compatible modems, this command is `AT &C1`.)
- Make sure the modem is configured to answer the phone only when DTR is high, and to drop the line when DTR goes low. (For Hayes-compatible modems, this command is `AT S0=1 &D3`.)
- For the best results in bidirectional mode, the non-volatile parameters in the modem should be configured for incoming calls, and the modem should be configured to reset to these parameters each time DTR is dropped. (For Hayes-compatible modems, this command is `AT &D3`.)
- The PortServer cannot switch the serial line baud rate depending on the kind of connection made, so you should configure the modem to lock the serial line speed at the highest baud rate the modem will go.
- Generally it is best to use hardware flow control on modem lines, and leave software flow control off. (Both the UUCP and XMODEM protocols send all 256 characters, so these protocols will not work with software flow control.)
- Note that many modems have external or internal jumpers that override the normal operation of DTR, DCD, RTS and CTS. Be sure to check this in your modem manual!
- Be sure to watch the LEDs on the PortServer front panel to monitor correct modem operation. In particular, verify that DCD is off when the modem is not connected. Verify that the modem does *not* answer the phone when DTR is low, and hangs up when DTR is dropped.

Configuring CU and UUCP to dial out without RealPort

Use FTP or the Digi BBS and download the “rtty” program. (See *The Digi Bulletin Board System* on page 103.) The source code will always be available there, and binaries will be provided for the most popular operating systems.

RTTY works by associating a particular pseudo tty port with a particular port or port “group” on the PortServer. The pseudo tty then acts enough like a regular port so that it fools most programs including kermit, uucp and cu.

Not all pseudo ttys can be used for this. RTTY does not work with streams-based pseudo ttys, and pseudo ttys associated with “clone” devices normally must be opened by the clone device. However, even systems with clone devices often maintain old-style BSD devices.

In general, you should read your UNIX man pages to find out what your system supports. If your system supports BSD-style pseudo ttys, you can find the devices available with:

```
ls /dev/pty*
```

Choose one or more of the alphabetically highest pseudo ttys, (the system allocates them in alphabetically) so you will have them to yourself at least most of the time.

The pseudo tty driver will not allow access to the “master” side of a pseudo tty by more than one program at a time, so once rtty grabs a pseudo tty, it controls it until it lets go. However, to drop a connection, rtty must close the device and then reopen it. While the device is closed for only a few milliseconds, it is still possible for another program to grab the device before rtty can resecure it!

If that happens, CU and UUCP will get confused. Selecting a high port number is generally good enough to minimize problems.

Assuming you have found `/dev/pty[pqrs][0-f]` above (64 ptys), and that you needed to configure four modem ports, you would probably be wisest to use `/dev/ptys[cd ef]` for your pseudo-modem ports.

If (for example) you want to use PortServer ports 1-4, you would add the lines below to your “rc” startup script. The parameter “1” says to wait one second after connect before sending data. (This is needed so that the modem will see DTR go high for a while before looking for “AT”). The “d” says to daemonize the program, and the “s” says to suppress the Copyright Notice during boot.

```
rtty -lds /dev/ttysc dbps-nodename 2101
rtty -lds /dev/ttysd dbps-nodename 2102
rtty -lds /dev/ttyse dbps-nodename 2103
```

```
rtty -lds /dev/ttysf dbps-nodename 2104
```

Note the use of the 21?? raw connect port numbers (as opposed to 20?? series telnet connect numbers). See *PortServer Port Numbers* on page 101.

Add a few lines like the following to your uucp “Devices” file. All baud rates are equivalent, since the pseudo tty device driver ignores them, but they must match up with the value given in your “Systems” file. On some systems, the “hayes” keyword is omitted; on other systems you will want to replace it with the name of the dialer script your modem uses.

```
ACU ttysc ttysc 38400 hayes
ACU ttysd ttysd 38400 hayes
ACU ttyse ttyse 38400 hayes
ACU ttysf ttysf 38400 hayes
```

Having done just these two things, the modems will now appear directly connected to cu and uucp, so you should be able to test your configuration by typing something like:

```
cu -l /dev/ttysc -b 38400 555-1212
```

Depending on your system, you may need to make a few more tweaks, but the rest of it is the same as you would encounter on any other directly connected port.

It is possible for several (or many) different computer systems on a network to configure pseudo-ttys associated with the same port (or port group) on an PortServer. This works because RTTY only attempts a connection when data is written to the pseudo tty. If the PortServer port is available, the connection is made and the program accessing the port can continue. If the port is already in use by another system the connection will fail, and RTTY will signal the application by momentarily closing and re-opening the pseudo-tty port. This is compatible with the way UUCP and CU work on most systems.

The RTTY program is provided on an as-is basis by Digi as a service to its customers, but because it is tricky to configure, and usually needed only by sophisticated users, it is not covered by our regular unlimited technical support policy. RTTY works well on most systems, but depends too much on non-standard features of the local UNIX system to be fully supported. Digi provides the source, internal documentation in the source, and an unlimited distribution license when used with our products. Most customers find it valuable, but there is no guarantee of success.

RTTY Program

The following is an extract from the RTTY source code mentioned on page 87, explaining the command usage. RTTY is provided on a limited-support basis for our customers, when used with the PortServer and other Digi network products.

```
/*
 * NAME
 * rtty - Connect a tty to a remote TCP port.
 *
 * SYNOPSIS
 * rtty [-dhw] tty host port
 *
 * DESCRIPTION
 * rtty attaches the master side of a named pseudo tty
 * to a TCP session.
 *
 * This is most often useful to allow a TCP terminal server
 * port to appear as a local tty on some host computer.
 *
 * -[0-9] Wait for data to be written to the slave side of
 * the pseudo tty before opening the connection;
 * open the connection and sleep the given number
 * seconds [0-9] before writing the data to the port.
 *
 * -d Daemonize. A detached child process is spawned
 * to perform the program function, ignoring all
 * signals.
 *
 * -h Hold the tty open so "stty" settings are not
 * disrupted and EOF's are not sent when the tty
 * is locally closed.
 *
 * -q Quit after one session is complete. Normally the
 * program loops to handle multiple sessions.
 *
 * -s Suppress the copyright notice.
 *
 * -w Wait for data to be written to the tty port before
 * executing the rsh command.
 *
 * -x Output debugging information. Specifying "x"
 * twice produces even more output.
 *
 * To associate "ttypf" with the dedicated printer device
 * connected to (PortServer) node ncx, port 4.
 *
 * rtty -dh ttypf ncx 2104
 *
 * To associate "ttysf" with a dial-in/dial-out (type mio)
 * modem attached to (PortServer) node dbps port 13.
 *
 * rtty -ld ttysf dbps 2113
 */

static char *copyright[] =
{
    "@(#)Copyright 1992, Digi International, All Rights Reserved.",
    "@(#)An unlimited use and distribution license is granted for use with,"
}
```

```
"@(#)and only with, Digi terminal servers and other network products.",  
0  
};
```

RJ Connectors

There are four types of modular plugs that can be used with the PortServer's RJ-45 10-pin jack. These are the 4 or 6-pin RJ-11 plugs, and the 8 or 10-pin RJ-45 plugs.

The 8 and 10-pin RJ-45 plugs are the same physical size, but the 10-pin version has one additional wire at each end of the row of contacts. Thus pins 1-8 of an 8-pin RJ-45 directly correspond to pins 2-9 of a 10-pin RJ-45 connector.

Similarly, the two RJ-11 plugs have the same physical dimensions, but the 6-pin version has an extra pin at each end. The RJ-11 plugs are physically smaller than RJ-45 plugs, but are designed so that they fit into the center of an RJ-45 jack. In this way, the four pins closest to the center of any size connector will always carry the same signals as the middle four pins of any other connector. The contacts of a 6-pin RJ-11 connector correspond directly to the middle six pins of an 8 or 10-pin RJ-45 connector, and so on.

The diagrams on the following pages illustrate the relationship of the various modular plug configurations to Digi's standard 10-pin RJ-45 jack, and show which RS-232 signals are available in each configuration.

10 Pin RJ 45 Plugs

The 10-pin RJ-45 plug carries all eight of the RS-232 signals supported by the PortServer hardware, plus the two ground lines, Signal Ground (SG) and Chassis Ground (GND). The 10-pin configuration includes the modem control lines Ring Indicator (RI) and Data Carrier Detect (DCD).

RJ-45 WIRING: 10 PIN PLUG TO 10 PIN JACK

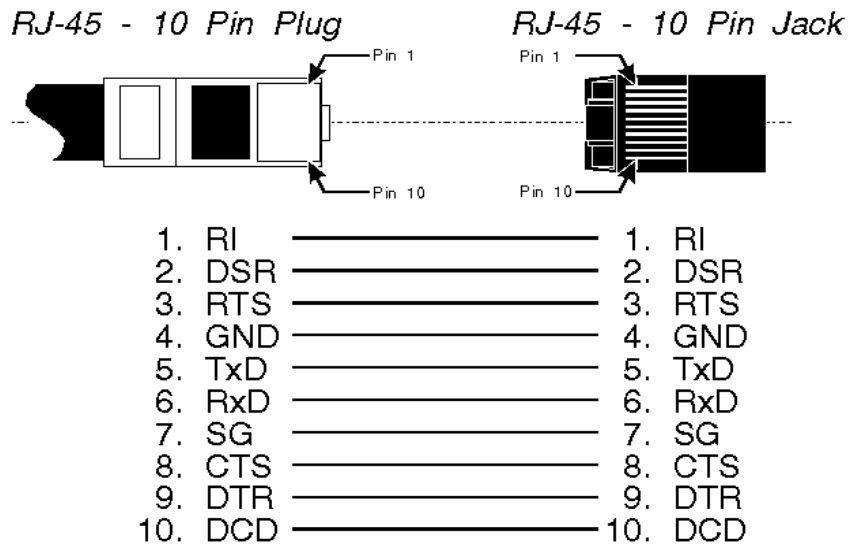

8 Pin RJ 45 Plugs

The 8-pin RJ-45 plug supports all of the RS-232 signals except the modem control lines RI and DCD. It is ideal for use with terminals and printers that require full hardware handshaking (as when both DSR and CTS must be satisfied for data transmission to occur).

Note: The PortServer software permits software rewiring the RJ-45 connectors so that DCD is available in 8-pin configurations. See *Modems* on page 86.

RJ-45 WIRING: 8 PIN PLUG TO 10 PIN JACK

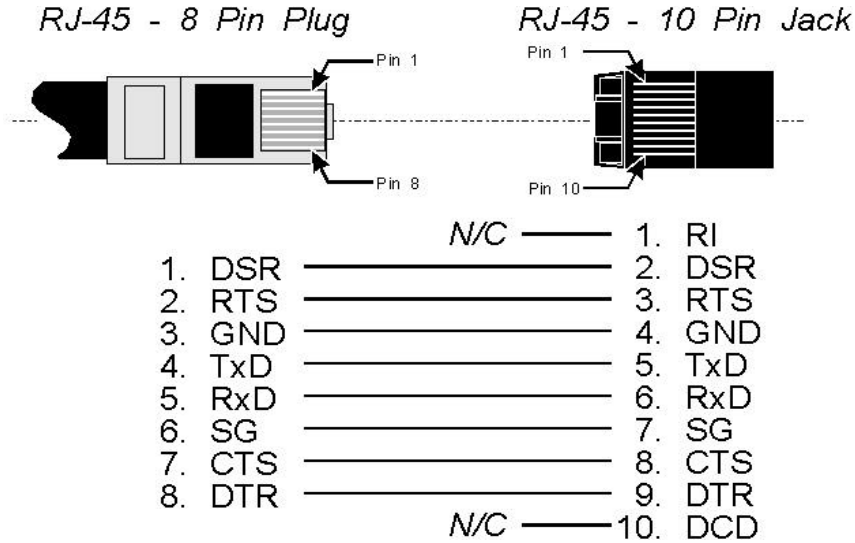

6 Pin RJ 11 Plugs

6-pin RJ-11 plugs can be used in hardware handshaking situations that require only RTS and CTS to be available.

RJ-11 WIRING: 6 PIN PLUG TO 10 PIN JACK

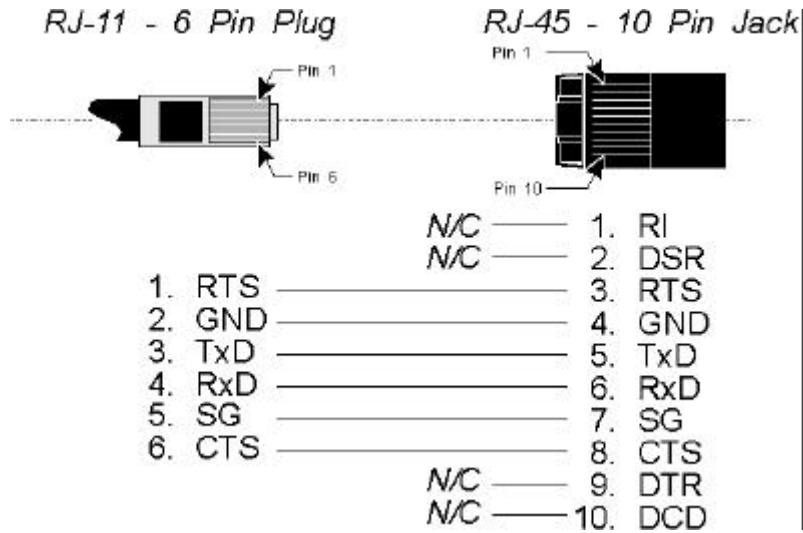

4 Pin RJ 11 Plugs

The 4-pin RJ-11 plug can be used in situations requiring no handshaking, or software handshaking (XON/XOFF). No hardware handshake lines are available with this configuration.

This is useful for the popular three-wire connection (TxD, RxD and Signal Ground) used for terminals and printers that support XON/XOFF handshaking.

RJ-11 WIRING: 4 PIN PLUG TO 10 PIN JACK

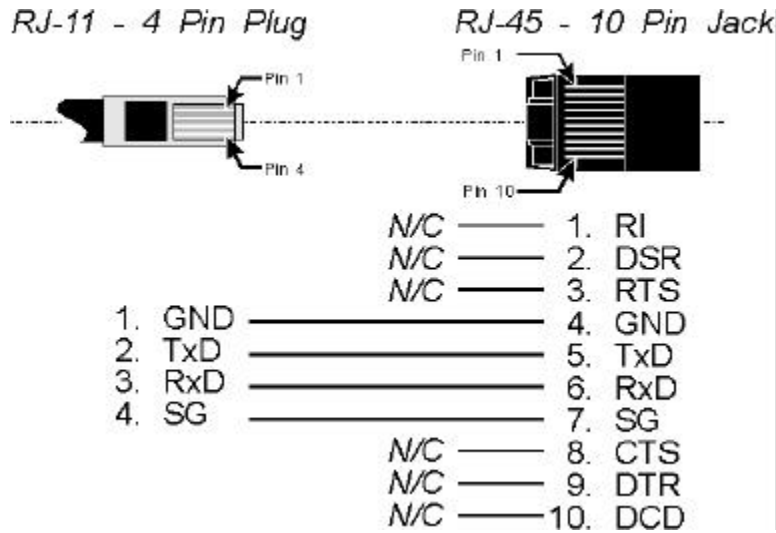

Digi RJ-45 to DB-25 Cable Legs

Since most RS-232 devices are equipped with DB-25 connectors, it is necessary to buy or build an adapter to transfer the signals to a DB-25 plug. The most simple and direct approach is to purchase ready-made Cable Legs from a Digi International dealer or distributor. These are made with a full 10-pin RJ-45 plug (which can be difficult to obtain in the retail market), connected via a two or four foot cable to a DTE-configured DB-25 plug.

RJ-45 TO DB-25 CABLE LEG

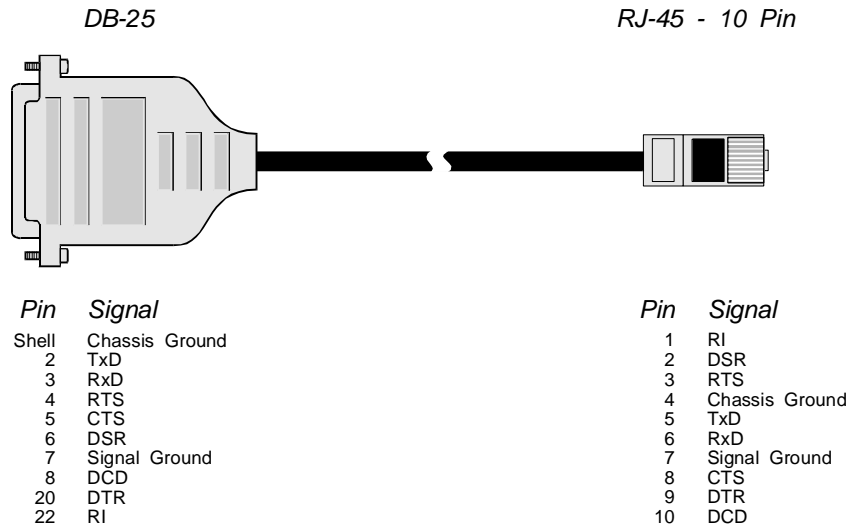

Cable Leg Options and Part Numbers

	DB-25 Male	DB-25 Female	DB-9 Male
24 Inch Cables	61020024	61030024	61070024
48 Inch Cables	61020048	61030048	N/A

The pin configuration of the DB-25 connector on the Cable Leg is shown in the diagram.

If you do not need full modem control, you can use one of the many commercially available RJ-45 to DB-25 adapters. These have both an 8-pin RJ-45 jack and a DB-25 plug in a housing no larger than that found on a standard DB-25 plug. The plug and jack are connected within the housing by jumpers which may be installed by the end-user in any desired configuration.

Connecting Modems

Modems are generally equipped with DB-25 connectors, so it is usually necessary to buy or build an adapter such as the ones mentioned previously. Since the modem control lines, RI (Ring Indicator) and DCD (Data Carrier Detect) are on pins 1 and 10, respectively, of Digi's RJ-45 jack, the adapter cable provided by Digi is ideal, since it has a 10-pin RJ-45 plug, and is terminated in a modem-ready, DTE-configured DB-25 plug.

Altpin

If you want to use 8-pin RJ-45 to DB-25 adapters, a software feature called ALTPIN has been incorporated into the PortServer software to swap the DCD and DSR signals. This makes DCD available on pin 1 of an 8-pin RJ-45 connector.

RJ-45 ALTPIN WIRING: 8 PIN PLUG TO 10 PIN JACK

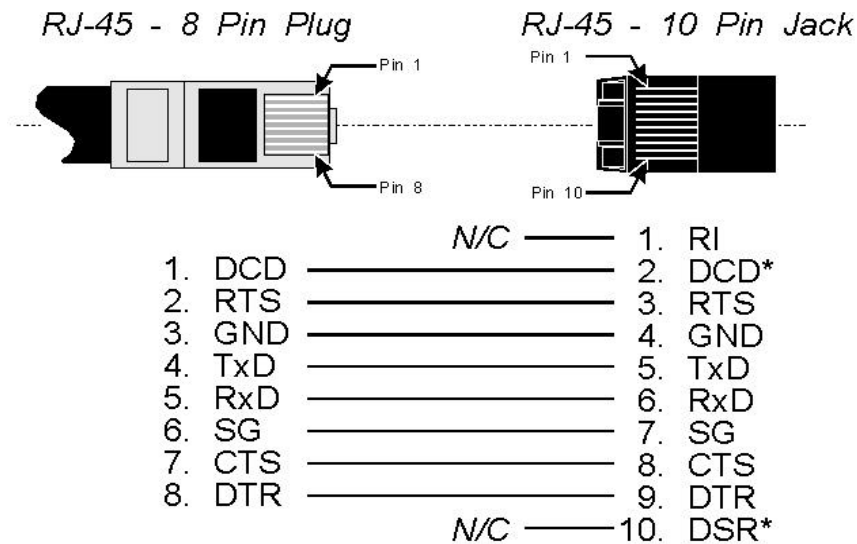

*Note that DCD and DSR have been swapped.

Digi device drivers do not require DSR in modem-control applications, and since almost all of today's modems have auto-answering capability, the Ring Indicator signal is generally unnecessary.

Note that to use Altpin, you must also configure the PortServer port for Altpin; see `set flow altpin` on page 45.

Multiple Sessions

Any user can use the multiple session feature if that user's port is configured to allow it. Users logged into a host with one of the `auto` options (`auto port` or `auto user`) cannot run multiple sessions, as this would defeat the security purpose of the Auto connections.

Multiple sessions are initiated one at a time from the command line. This is done by starting up one session, escaping to the command line, starting another session, escaping to the command line, starting another session and so on up to the maximum number of sessions configured for that port (`set port sess=number_of_sessions`—see page 52).

In the following examples, `<TESC>` refers to the telnet escape character. The default telnet escape character is `<Ctrl-]>` (Control-Right Bracket), and can be changed—see page 47.

In the middle of a telnet session, you can enter:

- `<TESC> <CR>` to return to the PortServer command line.
- `<TESC> <digit>` to switch to session `<digit>`, a valid active session number in the range 1-8
- `<TESC> <TESC>` to return to the last session.

In the middle of an Rlogin session, you can enter:

- `<CR> ~ <TESC> <CR>` to return to the PortServer command line.
- `<CR> ~ <TESC> <digit>` to switch to session `<digit>`, a valid active session number in the range 1-8
- `<CR> ~ <TESC> <TESC>` to return to the last session.
- `<CR> ~ .` to terminate the current session.

Switching to another session

At the PortServer command line, type the session number as the first character of a line to switch to the associated session. This is a special case, and does not require that you hit return after typing the number.

Closing a session

To close either a telnet or rlogin session, either log out of the remote system (which closes the session from the other end) or escape to the command line and type the close command.

Rlogin sessions may also be closed using the rlogin escape sequence “<CR> ~ .” (Carriage return / tilde / period).

How to use Multiscreen Multisession

If your port is configured to a terminal type (set ports term=*termtyp*e—see page 52) given in the TERM table, the PortServer automatically switches between screens on your terminal when the user switches between sessions. This requires that your termtyp supports multiple screen switch sequences—see *Configuring Multi Screens* on page 100.

The PortServer screen switching algorithms were carefully designed to preserve as much screen context as possible. It is, of course, not possible to keep screen context for four sessions on a terminal with only three screens. The PortServer does its best by keeping screen context on the three sessions most recently used, and losing context on the least recently used session.

If your terminal is configured for three screens (for example, WYSE 60 in ECON-80 mode) you may run up to three simultaneous sessions, switching back and forth without losing screen context. However if you escape to the PortServer command line, or open yet another session, the PortServer will clear and re-use the terminal screen least recently used to display that session. You will then be able to switch between the new session, and the last two other sessions without losing screen context, but when you go back to the least recently used screen, the PortServer will again clear and re-use the terminal screen to show that session.

Configuring Multiscreens

The PortServer supports up to 16 different terminal types. Each terminal type must have a different name, although a particular manufacturer's terminal may be known by several different names.

For example you might want to have separate names for a wyse 60 in 43 line mode (no screen switching), a wyse 60 in 24 line standard mode (2 screens available), a wyse 60 in 24 line ECON-80 mode (3 screens available) and even a wyse 60 in WYSE 50+ mode (6 screens available).

For each terminal, you must define the name, the number of screens used, the terminal screen clear sequence, and the sequence to switch to each screen page.

PortServer Port Numbers

The PortServer provides two ranges of TCP/IP service numbers that you can connect to from other systems:

2001 - 2099	Telnet Connect
2101 - 2199	Raw Connect

A connect made to any 20XX port uses the Telnet protocol, providing full Telnet compatibility. You would use the 20XX ports in commands like:

```
pr myfile | telnet dbps-nodename 2001
```

A connect to any 21XX service is a raw connection, passing 8-bit clean data at all times. This is useful with the RTTY command described on page 89, and for custom applications.

The last two digits in each number indicate to what port or group the user is to be connected. If the last two digits are 01 - 16, a connection is made to the specified port. Numbers greater than 16 indicate a *port group number*, as configured with `set port group=group_number` (see page 52).

When several PortServer ports are configured with the same group number, they work like a telephone “hunt group.” Any attempted connection goes to the lowest numerical port number that can currently accept a connection.

The `altip` command (page 40) can be used to define alternate IP addresses for telnetting to a port or huntgroup. (This option does not support raw connect.) You could replace `telnet abc 2080` with `telnet abcalt`, assuming that `abcalt` has an IP address associated with group 80 in the `altip` table, and `abcalt` is defined in a host table. The “group number” (rightmost two digits) should be in the range 17-99.

Note: Choosing the wrong range of service numbers, (for example, 20xx instead of 21xx) is a common source of user problems.

Specifications

Network Compatibility

Ethernet IEEE 802.3 standard
10BaseT (Twisted Pair)
10base2 (Thin Ethernet)

Ports

8 or 16 RS-232 asynchronous serial ports with RJ-45 connectors
1 10baseT twisted-pair Ethernet port with an RJ-45 8-pin connector
1 10base2 Ethernet port with a BNC coaxial connector

Power Requirements

+5 volts \pm 5%	1250 ma typical
+12 volts \pm 5%	250 ma typical
-12 volts \pm 5%	50 ma typical

Environmental

Ambient temperature	16.6° C (60° F) to 29.4° C (85° F)
Relative humidity	20% to 80%
Altitude	0 to 2135 meters (0 to 7,000 feet)

Certification

The Digi International PortServer terminal server is certified to meet the following emissions and safety standards:

Emissions:

FCC Part 15, Subpart J, Class A
CSA C180.8-M83, Class A
CISPR 22, Class A

Safety:

UL Recognized, UL 1950
CSA Certified, CSA C22.2 No. 220
IEC 380/950 Safety (TUV)

Digi Support Services

The Digi Bulletin Board System

Digi provides an electronic bulletin board service (BBS) for our customers. This bulletin board provides general and technical information about Digi's products.

The Digi BBS allows users to download software drivers as soon as they become available. There is also a feature to allow users with problems or questions about Digi products to leave messages to Digi Technical Support.

Using the Digi BBS is easy. Simply dial **(612) 943-0550** or **(612) 943-0549**. In Europe, dial **+49 221 9205211**; in Asia, dial **+65 735 2460**. The bulletin board accepts calls at 1200, 2400, 9600 and 14.4K baud. V.32, HST 14.4, V.42 and V.42*bis* standards are supported, with full MNP class 1-5 error correction and data compression.

The recommended modem communications parameters are 8 bits, no parity and one stop bit (**8 N 1**). Other settings may also work.

Download protocols include Zmodem, Xmodem, Ymodem, Kermit and others.

Internet FTP Server

Digi has set up an Anonymous FTP server for those with access to the Internet network. The address is <ftp.digibd.com>. Log in as `anonymous`, and enter your E-mail address when asked for a password. Drivers and installation tips are located in the `/drivers` directory. A text file, `download.doc`, gives information on uncompressing the files after downloading. Tip: Be sure to enter "bin" before downloading, to ensure binary transfer of files.

World Wide Web Server

Product information, manuals, new product announcements, programs, application stories and more can be obtained through the World Wide Web. Our address is <http://www.digibd.com>.

DigiFACTs FaxBack Server

Manuals and technical information can also be obtained by FAX. To use the FaxBack server, simply call (612) 943-0573 on a touch tone phone.

Information About Your System

Serial number of your Digi product: _____

Make, model and clock speed of your computer: _____

How much RAM does your computer have? _____

Hard disk controller: Type: _____ Memory addressed at: _____

I/O port used: _____ IRQ: _____

LAN card: Type: _____ Memory addressed at: _____

I/O port used: _____ IRQ: _____

Other: Type: _____ Memory addressed at: _____

I/O port used: _____ IRQ: _____

Operating system: _____ Version: _____

Digi device driver version: _____

Technical Support

At Digi, we are proud of our products, and support them. Our dealers and distributors are fully trained on our product line, so that they can help you on a technical level should assistance be needed.

Your first level of support is your Digi dealer, the place where you purchased your Digi product. Your dealer has the training to help you with any installation questions or difficulties you might have.

If you still experience difficulties (after contacting your first level of support), Digi has a staff of Technical Support Specialists that can assist you. They can be reached at **(612) 943-0578**. In Europe, call **+49 221 920520**, and in Asia, call **+65 735 1318**. FAX numbers are: (612) 943-0579 (USA), +49 221 9205210 (Europe) and +65 735 1312 (Asia).

When you call Digi Technical Support, please call from a position where you can operate your system. Also, please fill out the form on the facing page before calling, so your Technical Support representative can have a clear picture of your system and any potential conflicts between devices.

Digi Technical Support can also be reached via Internet E-mail. Please send correspondences to support@digibd.com, and include your voice and FAX phone numbers.

Customer Service

Digi also has a staff of Customer Service representatives to help you with software and documentation update requests, as well as Returned Merchandise Authorizations (RMAs) in case you need to return your board to Digi for repair (see *Return Procedures* below). They can be reached at **(612) 943-0577**.

Digi Customer Service can also be reached via Internet E-mail. Please send correspondences to cust_serv@digibd.com, and include your voice and FAX phone numbers.

Return Procedures

All Digi products have a five-year parts and labor warranty, and we are ultimately responsible for any defective parts, according to the limits specified in the warranty. However, many of the reported problems are due to factors other than defects in the product itself. To save you time and possibly additional cost, Digi asks that you *first* try to resolve any difficulties by contacting our Technical Support representatives at **(612) 943-0578**.



Be sure to have the serial number of your board at hand before calling Technical Support.

Returns should be directed to the dealer or distributor from whom you purchased the product. If you need to return your Digi product for repair, it is first necessary to obtain an RMA (Returned Merchandise Authorization) number from Digi, by speaking to a Digi Customer Service representative. Authorized returns should be shipped to Digi International, 10000 West 76th Street, Eden Prairie, MN 55344. The RMA number should appear on the shipping carton, on or near the address label.

Note:

Products received without an RMA number clearly marked on the outside of the package will be returned, unopened, to the sender

Index

—A—

- Abbreviations, 28
- abort output
 - char (ao), 62
- admin, 31
- aixon, 45
- altip, 40, 101
- Altpin, 45
 - wiring for modem, 97
- Are you there?
 - char (ayt), 62
- arp, 41
- Auto
 - set port for auto login, 51
- Auto connect
 - port, 79
 - user, 78
- Auto-connect port
 - security, 79
- Auto-connect user
 - security, 78

—B—

- baud
 - setting, 48
- BBS, 103
- bin
 - binary connection, 51
- boot, 31
- bootfile, 43
- boothost, 43
 - filename, 43
- break
 - char (brk), 62
 - command, 48
- Bulletin Board, 103

—C—

- Cable

- 3-wire, 4
- close, 33, 37, 60
- cmdprompt
 - changing, 50
- config, 42
- cpconf**, 32, 33
- csize
 - char size, 48
- Ctrl-]
 - telnet escape, 47, 98
- cts, 45
- cu, 87
- Customer Assistance, 105
- Customer Service, 105

—D—

- dcd, 45
- Default Settings, ii
- dest
 - specify port destination, 51
- Device
 - set ports for devices, 51
- Digi BBS, 103
- domain, 42

—E—

- edelay
 - setting, 52
- eewrite, 31, 35
- E-Mail addresses, 105
- eof, 47
- erase, 47
 - char (ec), 62
- Erase line
 - char (el), 62
- Escape
 - char (escape), 62
- escape char
 - telnet, 23, 47
- exit, 33, 37

—F—

FaxBack, 103
File
 remote boot, 43
Flow control, 44
 appendix, 81
Front Panel, 69
FTP server, 103

—G—

gateway, 42
Go ahead
 char (ga), 62
Group
 defining, 52

—H—

Help screens, 29
high-order bit
 stripping, 48
Host
 host parameters, 46
 set, 46
 setting port as, 51

—I—

IFC, 69
info, 33
info clear, 33
Internet, 103
Interrupt process
 char (ip), 62
intr, 47
ipaddress, 42
ixoff, 45
ixon, 45

—K—

Keys
 setting keys, 47
kill, 47
kill tty, 35

—L—

Line parameters, 48
login

 set if required, 50
Logins
 parameter setting, 49
logprompt
 setting, 50

—M—

Mode
 telnet parameters, 60
Modem
 connecting, 97
 device, 82, 83
Modem / In
 setting port as, 51
Modem / Out
 setting port as, 51
Modem In/Out
 setting port as, 51

—N—

nameserv, 42
netcx
 option, 42
newname
 set users, 57
newpass, 36
No Operation
 char (nop), 62
node name, 42
nodename, 63

—O—

OFC, 69
onclr, 49

—P—

Parity
 input checking, 48
 setting, 49
parity errors
 what PortServer should do, 48
Passprompt
 changing password prompt, 50
passwd, 50
Password
 prompt, 50
 set required, 50
Ports

- setting parameters, 51
- Printer
 - device, 82
 - setting port as, 51

—Q—

- Quick Start, 3

—R—

- Range, 38
- RARP, 5
- Remote Boot, 43
- Return Procedures, 105
- ri, 45
- RJ Connectors, 91
- RJ-11 4 pin, 95
- RJ-11 6 pin, 94
- RJ-45 10 pin, 92
- RJ-45 8 pin, 93
- RMA, 106
- Route
 - routing information, 53
- rts, 45

—S—

- Security**, 77

- Send
 - send telnet character, 62

- Sessions
 - setting maximum, 52
 - switching between, 23

- set
 - altip, 40
 - config, 42
 - host, 46

- set config
 - bootfile, 43
 - boothost, 43
 - domain, 42
 - gateway, 42
 - ip, 42
 - myname, 42
 - nameserv, 42
 - submask, 43

- set flow
 - aixon, 45
 - altpin, 45
 - cts, 45
 - dcd, 45

- ixoff, 45
- ixon, 45
- ri, 45
- rts, 45
- set keys
 - eof, 47
 - erase, 47
 - intr, 47
 - kill, 47
 - tesc, 23, 47
 - xoff, 47
 - xoffa, 48
 - xon, 47
 - xona, 48

- set line
 - baud, 48
 - break, 48
 - csize, 48
 - error, 48
 - inpck, 48
 - istrip, 48
 - onlcr, 49
 - parity, 49
 - stopb, 49

- set logins
 - cmdprompt, 50
 - login on/off, 50
 - logprompt, 50
 - passprompt, 50
 - passwd, 50
 - verbose, 50
 - write, 50

- set ports
 - auto, 51
 - bin, 51
 - dest, 51
 - dev, 51
 - dport, 52
 - edelay, 52
 - group, 52
 - sess, 52
 - termtype, 52
 - uid, 52

- set users
 - newname, 57

- SNMP
 - support, 66

- Status
 - telnet status, 62

- stopb
 - setting stop bits, 49

- submask, 43

- Switching between sessions, 23

Synchronize process
char (synch), 62

—T—

Technical Support, 105
telnet
 characters, 62
 command, 26, 63
telnet escape character, 23, 47
Term
 terminal escape sequences, 54
Terminal
 device, 82
 setting port as, 51
Termtyp
 setting, 52
tesc, 23, 47
TFTP
 error messages, 44
tim2liv, 41
Trivial File Transfer Protocol
 error messages, 44

—U—

User index, 52
Users
 table, 56
uucp, 87

—V—

verbose, 50

—W—

Who
 list current users, 59
World Wide Web, 103
write option, 50

—X—

xoff
 set, 47
xoffa, 48
xon
 set, 47
xona, 48