



PortServer II

Configuration and Administration Guide

92000271A

The Digi logo is a trademark of Digi International.

All other brand and product names are trademarks of their respective holders.

© Digi International Inc., 1998 All Rights Reserved

<http://www.dgii.com>

Information in this document is subject to change without notice and does not represent a commitment on the part of Digi International.

Digi provides this document “as is”, without warranty of any kind, either expressed or implied, including, but not limited to, the implied warranties of fitness or merchantability for a particular purpose. Digi may make improvements and/or changes in this manual or in the product(s) and/or the program(s) described in this manual at any time.

This product could include technical inaccuracies or typographical errors. Changes are periodically made to the information herein; these changes may be incorporated in new editions of the publication.

Contents

Chapter 1	Introduction to PortServer II Configuration	
	About Configuration Commands.....	1-2
	About the Command Line Interface	1-3
	Configuration Methods	1-4
Chapter 2	Configuration Examples	
	Terminal Server Configuration Without RealPort	2-2
	Terminal Server Configuration Using Autoconnection ..	2-4
	Terminal Server Configuration Using RealPort	2-6
	Dial-Out PPP Connection to a Host	2-8
	Dial-Out PPP Network-to-Network Connection	2-10
	Dial-In PPP Connection Using RADIUS	2-12
	PPP Dial-In Connection Without RADIUS	2-13
	Frame Relay Connection	2-14
	Dial-In PPP Connection and Proxy ARP	2-16
Chapter 3	Configuring the Ethernet Interface	
	Configuring an IP Address and Mask	3-2
	Configuring a Default Gateway	3-3
Chapter 4	Configuring RealPort Connections	
	About RealPort	4-2
	Configuring PortServer II for RealPort	4-3
Chapter 5	Configuring Printer Connections	
	Configuration Considerations	5-2
	Configuring Printer Connections	5-4
	Configuring a Port for Direct-Access Printing	5-5
Chapter 6	Configuring Terminal and Computer Connections	
	Configuring Terminal Connections	6-2
	About Computer Connections	6-4

Chapter 7	Configuring Modem Connections	
	Tips on Configuring Your Modem	7-2
	Configuring Incoming-Only Modem Connections	7-3
	Configuring Outgoing and Bi-Directional Modem Connections	7-5
Chapter 8	Configuring PPP and SLIP Connections	
	Configuring PPP Connections	8-2
	Configuring SLIP Connections	8-6
	Introduction to Filters for PPP and SLIP Connections ...	8-8
	Filtering Criteria	8-9
	Filtering Rules	8-10
	Filter Examples	8-11
Chapter 9	Configuring Frame Relay Connections	
	Planning Frame Relay Connections	9-2
	Frame Relay Configuration Procedure	9-3
Chapter 10	Configuring IP Routing	
	Introduction to Routing	10-2
	About RIP Routing Updates	10-3
	Configuring Static Routes	10-5
	Configuring Dynamic Routes Using RIP	10-7
	Configuring Proxy ARP	10-9
Chapter 11	Configuring the SNMP Agent	
	About SNMP and the PortServer II Agent	11-2
	Configuration Procedure	11-4
Chapter 12	Configuring Security Features	
	Controlling Access to the PortServer II Configuration .	12-2
	Controlling Access to Inbound Ports	12-3
	Controlling Access to Outbound Ports	12-5
	Controlling Access to the PortServer II Command Line	12-6
	Using RADIUS to Authenticate Users	12-7
	Issuing User Passwords	12-8

Chapter 13	Configuring Autoconnection	
	About Autoconnection	13-2
	Configuring Autoconnection By Port	13-3
	Configuring a User for Autoconnection	13-4
Chapter 14	Configuring DNS	
	About the Domain Name System	14-2
	Configuration Procedures	14-3
Chapter 15	Managing the OS and Configuration	
	Upgrading the OS	15-2
	Configuring PortServer II from a Remote Host	15-4
	Resetting the Configuration to Defaults	15-6
Chapter 16	Troubleshooting Tools	
	Introduction to PortServer II Controls and LEDs	16-2
	Running the Power On Self Test	16-3
	Running Hardware Diagnostics	16-4
	Displaying Serial Port Status	16-8
	Displaying Ethernet Status	16-9
	Tools for Solving Network Problems	16-10
Appendix A	Configuring CU and UUCP To Dial Out	
	About RTTY	A-2
	Description of Operation	A-3
	Configuring Your System	A-4
	RTTY Program	A-5

Index

About This Guide

Purpose

This guide provides the following:

- An introduction to the PortServer II configuration, which includes information on how to use the command line interface, how to access online help, and other topics that must be understood before you begin to configure PortServer II
- Configuration examples
- Configuration and administration procedures

Audience

This manual is intended for the person responsible for configuring and administering PortServer II. It assumes that this person has experience configuring network devices and is familiar with networking concepts.

Scope

This manual provides step-by-step instructions for configuring and administering PortServer II's main features. It does not address how to configure every PortServer II option, provide complete information on commands, or discuss hardware installation. These topics are covered in other documents in the PortServer II library.

chapter **1**

**Introduction to
PortServer II Configuration**

Introduction

This chapter provides information you need before you can configure PortServer II. It discusses the following:

- About Configuration Commands1-2
- About the Command Line Interface1-3
- Configuration Methods1-4

About Configuration Commands

About Configuration Commands

You configure PortServer II by entering commands, either one at a time from the PortServer II command line or as a batch file downloaded from a host.

Command Permission Levels

Most PortServer II commands that change the configuration require root privileges.

List of Configuration Commands

Here is a list of commands used to configure PortServer II features:

Command	Configures...
set altip	Alternate IP addresses, which are IP addresses that both identify the PortServer II and a specific outbound port
set arp	IP address-to-ethernet address mappings for PortServer II's ARP table. This command is seldom used.
set auth	Access permissions to serial ports for users making outbound calls
set chat	Chat table entries
set config	The PortServer II ethernet interface
set device	Modems and other devices used for output
set filter	Filters, which are used to initiate and control PPP and SLIP connections
set flow	A port's flow control attributes
set forwarding	Routing parameters
set framerelay	Frame relay parameters
set frdlci	Frame relay virtual circuit attributes
set host	The host name table
set ippool	An IP address pool
set keys	Keys and key sequences used to generate certain characters and command functions
set line	Serial line attributes
set logins	Login attributes
set menu	User menus
set modem	Modems for dial-out PPP and SLIP connections
set ports	Ports
set radius	RADIUS client software
set route	Static routes
set script	Modem scripts
set service	Names that will be associated with TCP and UDP ports
set terms	Terminal types
set time	PortServer II time and date
set trace	Trace attributes
set user	User attributes
snmp	SNMP agent parameters

About the Command Line Interface

Introduction

This section discusses the PortServer II command line interface. It provides information on the following topics:

- The keys you use to navigate along the command line and edit commands
- PortServer II on-line help
- Tips on abbreviating PortServer II commands

Navigation and Editing Keys

Use the following keys to navigate along the command line and edit PortServer II commands:

Action	Keys
Move the cursor back one space	Ctrl b
Move the cursor forward one space	Ctrl f
Delete the character to the left of the cursor	Back space
Delete the character under the cursor	Delete
Delete the character to the left of the cursor	Ctrl h
Scroll back through commands	Ctrl p
Scroll forward through commands	Ctrl n
Execute the command typed on the command line	Enter

Online Help

On-line help is available for PortServer II commands. The following describes how to access help:

For information on...	Type
All commands	? (with no additional parameters)
A specific command	The command and then ? Example: info ? Example: set user ?

Abbreviating Commands

All PortServer II commands can be abbreviated. You need only supply a sufficient number of command letters to uniquely identify the command.

Configuration Methods

Methods of Supplying Commands

There are three methods for supplying PortServer II with the commands required to configure it. They are

- By accessing the command line from a directly-connected terminal
- By accessing the command line from a LAN-based telnet terminal
- By downloading a configuration file from a host

Configuration Prerequisite: Set Up the Configuration Terminal

This section describes how to set up a configuration terminal, which you usually must do before you can configure PortServer II. The only way to avoid this step is to configure PortServer II from a LAN-based telnet session and to use a RARP server to configure PortServer II's ethernet interface with an IP address and mask.

Set Up Procedure

Here is how you set up the configuration terminal:

1. Cable a terminal to a PortServer II serial port. For instructions, see the *PortServer II Hardware Installation Guide*.
2. Set terminal parameters to the following, which are PortServer II default port settings:
 - VT-100 emulation
 - 9600 baud
 - 8-bit characters
 - 1 stop bit
 - No parity

Configuration from a Directly-Connected Terminal

This section describes how you configure PortServer II from a directly-connected terminal.

Starting Point

This procedure assumes that you have set up the configuration terminal.

Procedure

1. Turn on the PortServer II and then press `Return` or `Enter`.
2. At the `login` prompt, type in `root`, which is the administrator's user name.
3. At the `passwd` prompt, type in `dbps`, which is the default root password.
4. Enter commands as required for your configuration.

***Configuration From a
LAN-Based
Telnet Session***

This section describes how you configure PortServer II from a LAN-based system running telnet.

Starting Point

PortServer II must have an IP address in order for you to telnet to it. You can assign this address in one of two ways. If you have a RARP (reverse address resolution protocol) server on the LAN, PortServer II can acquire address information automatically. If not, you must manually configure the IP address from a directly-connected terminal. Consequently, if you intend to use a RARP server, the procedure assumes that you have set up PortServer II's IP address on the RARP server. If you intend to manually configure address information, this procedure assumes that you have set up the configuration terminal.

Configuration Procedure When RARP Is Used

1. Turn PortServer II. (It will use RARP to acquire an IP address)
2. Telnet to the PortServer II using the IP address just acquired.
3. At the `login` prompt, type in `root`, which is the administrator's user name.
4. At the `passwd` prompt, type in `dbps`, which is the default root password.
5. Enter commands as required for your configuration.

Manual Configuration Method

1. Configure the PortServer II Ethernet interface with the `set config` command, specifying an IP address (on the `ip` field) and a mask (on the `submask` field).
2. Telnet to the PortServer II using PortServer II's IP address as the destination.
3. At the `login` prompt, type in `root`, which is the administrator's user name.
4. At the `passwd` prompt, type in `dbps`, which is the default root password.
5. Enter commands as required for your configuration.

Downloading the Configuration from a Host

This section describes how you download a PortServer II configuration file.

Starting Point

This procedure assumes that

- You can access the PortServer II command line, either from a directly-connected terminal or using telnet over the LAN
- PortServer II has an IP address and mask for its Ethernet interface
- You created a file on the system from which the configuration will be downloaded and entered appropriate configuration commands
- You ensured that TFTP is running on the host from which the configuration will be downloaded

Procedure

Supply a `cpconf` command that specifies the IP address (or name) of the source host and file (on the `fromhost` field).

Example

```
cpconf fromhost 190.150.150.10 ps-cnfg1
```

chapter **2** **Configuration Examples**

Introduction

This chapter provides several simple, but complete, examples of PortServer II configurations. If you find that the examples implement exactly the features needed for your network, simply copy them, making appropriate substitutions for site-specific information such as IP addresses. Quite likely, however, you will be able to use the examples as a starting point only and will need the information provided in other chapters in this manual and in the *PortServer II Command Reference* to complete your configuration.

In This Chapter

This chapter provides the following discussions:

- Terminal Server Configuration Without RealPort2-2
- Terminal Server Configuration Using Autoconnection . .2-4
- Terminal Server Configuration Using RealPort2-6
- Dial-Out PPP Connection to a Host2-8
- Dial-Out PPP Network-to-Network Connection2-10
- Dial-In PPP Connection Using RADIUS2-12
- PPP Dial-In Connection Without RADIUS2-13
- Frame Relay Connection2-14
- Dial-In PPP Connection and Proxy ARP2-16

Terminal Server Configuration Without RealPort

Introduction

In this configuration, PortServer II functions as a terminal server, providing telnet and rlogin access to hosts. This configuration enables the following:

- Telnet or rlogin access to the LAN-based hosts, both from the locally-connected terminals and from devices accessing the LAN from the telephone network.
- Access for the LAN-based hosts to PortServer II ports (sometimes called reverse telnet) and LPD printing to the printer connected to PortServer II.

Related Information

For more information on configuring

- The Ethernet interface, see Chapter 3.
- Terminal connections, see Chapter 6
- Modem connections, see Chapter 7
- Printer connections, see Chapter 5

Illustration

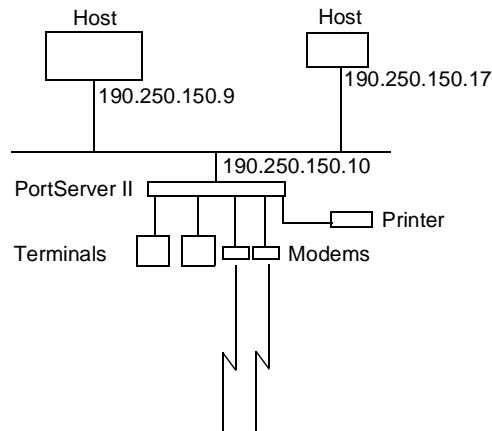

Configuration

```
set config ip=190.250.150.10
  submask=255.255.255.0 ..... (1)

set ports range=2-3 dev=term
set line range=2-3 baud=9600
set flow range=2-3 ixon=on ixoff=on ..... (2)

set ports range=4-5 dev=mio
set line range=4-5 baud=115200
set flow range=4-5 ixon=off ixoff=off
  rts=on cts=on ..... (3)

set user name=user1 ..... (4)

set ports range=15 dev=prn
set line range=15 baud=9600
set flow range=15 ixon=on ixoff=on ..... (5)
```

Configuration Notes

1. The `set config` command configures the IP address and mask for PortServer II's Ethernet interface.
2. The first `set ports`, `set line`, and `set flow` commands configure ports 2 and 3 for terminal connections.
3. The next `set ports`, `set line` and `set flow` commands configure the ports for bidirectional modems. Software flow control (the default) is explicitly shut off and hardware flow control turned on using the `set flow` command.
4. The `set user` command defines a user, which assigns a user name for login purposes. All PortServer II users can login with this name. Because no password is defined (see the `newpass` command), the user name functions as a password as well.
5. This `set ports`, `set line` and `set flow` commands configure port 15 for a printer using software flow control.

Terminal Server Configuration Using Autoconnection

Introduction

This example shows a PortServer II functioning as a terminal server implementing autoconnection.

- The terminals are connected to autoconnect ports. Consequently, when a user presses a terminal key, an automatic connection to a host is made.
- The modem ports are not configured for autoconnection, but a port user is, which means that as soon as this particular user supplies a login, an automatic connection to a host is made.

Related Information

For more information on configuring

- The Ethernet interface, see Chapter 3
- Terminal connections, see Chapter 6
- Autoconnections, see Chapter 13
- User login information, see the `set login` command in the *PortServer II Command Reference*
- Modem connections, see Chapter 7

Illustration

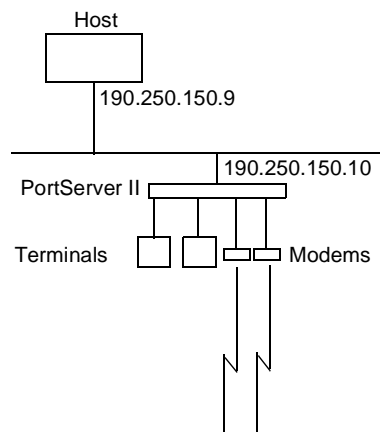

Configuration

```
set config ip=190.250.150.10
  submask=255.255.255.0

set ports range=2-3 dev=term auto=on
dest=190.250.150.9 dport=23
set line range=2-3 baud=9600
set flow range=2-3 ixon=on ixoff=on ..... (1)

set ports range=9-10 dev=min
set line range=9-10 baud=115200
set flow range=9-10 ixon=off ixoff=off
  rts=on cts=on ..... (2)

set user name=user1 autoconnect=on
  defaultaccess=autoconnect autohost=190.250.150.9
  autoport=23 password=off ..... (3)
```

Configuration Notes

1. The first set of `set ports`, `set line` and `set flow` commands configure ports 2 and 3 for terminals, autoconnection, telnet (`dport=23`), and software flow control.
2. The second set `ports`, `set line`, and `set flow` commands set up ports 9 and 10 for incoming modem connections and RTS/CTS flow control.
3. The `set user` command configures the user for automatic connection to the host specified on the `autohost` field using telnet (`autoport=23`).

Terminal Server Configuration Using RealPort

Introduction

In this example, the PortServer II is simply providing ports for the LAN-based host using RealPort. The PortServer II configuration is exceedingly simple because port attributes are configured on the host itself.

Related Information

For more information on configuring

- The Ethernet interface, see Chapter 3
- RealPort, see Chapter 4

Illustration

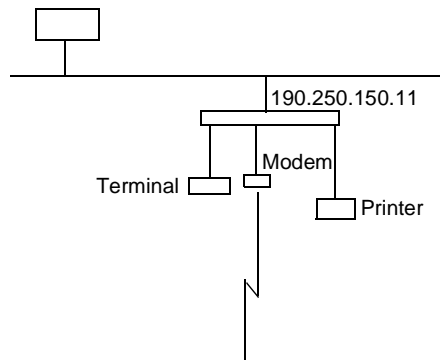

Configuration

```
set config ip=190.250.150.11  
submask=255.255.255.0 realport=771 ..... (1)  
set ports range=2-4 dev=prn ..... (2)
```

Configuration Notes

1. The `set config` command configures the internet address and mask for PortServer II's Ethernet interface and configures the RealPort TCP port (`realport=771`).
2. The `set ports` command configures ports 2, 3, and 4 for Realport. This command specifies `dev=prn`, which is an appropriate device type for RealPort.

Dial-Out PPP Connection to a Host

Introduction

In this configuration, PortServer II has a dialout PPP link to a host.

Related Information

For more information on configuring

- The Ethernet interface, see Chapter 3
- IP routing, see Chapter 10
- Modem connections, see Chapter 7
- Modem and login scripts, see the `set scripts` command in the *PortServer II Command Reference*
- PPP connections, see Chapter 8

Illustration

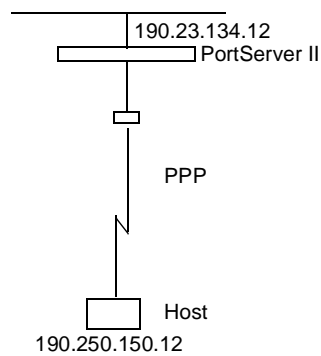

Configuration

```
set config ip=190.23.134.12
  submask=255.255.255.0

set forwarding state=passive ..... (1)

set ports range=9 dev=mout
set line range=9 baud=115200
set flow range=9 ixon=off ixoff=off
  rts=on cts=on ..... (2)

set script name=dialstd
  s1="M{atdt%n\r} [BUSY]* [CONNECT]+ S50 T=" ..... (3)

set device name=netdev dialer=dialstd
  ports=9 ..... (4)

set user name=user1 netservice=on
  defaultaccess=netservice protocol=ppp pppauth=none
set user name=user1 ipaddr=190.250.150.12
  ipmask=255.255.255.0
set user name=user1 loginscript=loginscript p1=fuzz
  p2=fuzz n1=555-1234
set user name=user1 device=netdev dialout=on
..... (5)
```

Configuration Notes

1. The `set forwarding` command configures PortServer II for routing using RIP, though `state=passive` means that PortServer II will listen for routing updates but not send them out.
2. The `set ports`, `set line` and `set flow` commands configure port 9 for dialout modems using hardware flow control.
3. The `set scripts` command configures a dialer script.
4. The `set device` command references the dialer script to be used for port 9.
5. The `set user` commands configure attributes of the PPP link, which include the following:
 - PPP connections can be initialized (`netservice=on`)
 - No CHAP or PAP authentication (`pppauth=none`)
 - The IP address of the remote peer (on the `ipaddr` field)
 - A reference to the default login script (on the `loginscript` field)
 - The login name and password that this user uses on the remote system (on the `p1` and `p2` fields), which are passed to the remote system by login script.
 - The telephone number that is used by the dialer script (on the `n1` field)
 - `dialout=on`, which enables this outbound PPP connection

Dial-Out PPP Network-to-Network Connection

Introduction

In this configuration, PortServer II functions as a router in a LAN-to-LAN configuration.

Related Information

For more information on configuring

- IP routing, see Chapter 10
- Modem connections, see Chapter 7
- Modem scripts, see the `set scripts` command in the *PortServer II Command Reference*
- PPP connections, see Chapter 8

Illustration

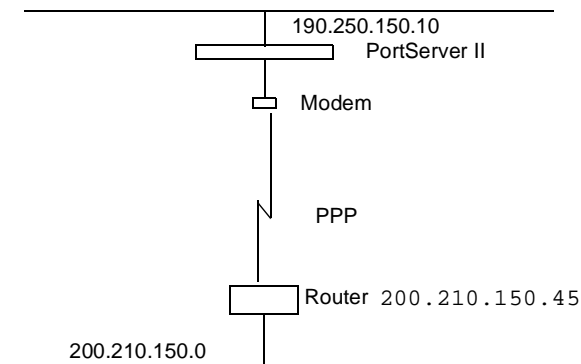

Configuration

```
set config ip=190.250.150.10
  submask=255.255.255.0 ..... (1)
set forwarding state=active ..... (2)
set ports range=9 dev=mout
set line range=9 baud=115200
set flow range=9 ixon=off ixoff=off
  rts=on cts=on ..... (3)
set script name=dialer1
  s1="M{atdt%n\r} [BUSY]* [CONNECT]+ S50 T=" ..... (4)
set device name=netdev dialer=dialstd ports=9 .... (5)

set user name=user1 protocol=ppp mtu=1500
  netSERVICE=on defaultaccess=netSERVICE
set user name=user1 ipaddr=200.210.150.45 dialout=on
  ipmask=255.255.0.0 pppauth=none device=netdev .....
set user name=user1 loginscript=loginscript p1=fuzz
  p2=fuzz nl=555-1234 .....
set user name=user1 netrouting=both ..... (6)
```

Configuration Notes

1. The `set config` command configures PortServer II's Ethernet interface.
2. The `set forwarding` command configures PortServer II for dynamic routing. The `state=active` field means that PortServer II both sends and receives routing updates.
3. The `set ports`, `set line` and `set flow` commands configure port 9 for outbound modem connections using CTS/RTS flow control.
4. The `set script` command configures a dialer script that is referenced by a `set device` and `set user` commands.
5. The `set device` command references the dialer script to be used for port 9.
6. The `set user` commands configure the attributes of the PPP link.

Dial-In PPP Connection Using RADIUS

Introduction

In this configuration, PortServer II uses a RADIUS server to provide a dial-in PPP connection. The attributes of the PPP connection, which can also be specified with `set user` commands, are specified on the RADIUS server.

Related Information

For more information on configuring

- Modem connections, see Chapter 7
- Modem scripts, see the `set scripts` command in the *PortServer II Command Reference*
- RADIUS, see Chapter 12

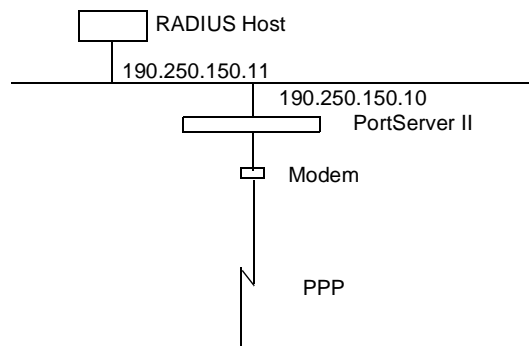

Configuration

```
set config ip=190.250.150.10
  submask=255.255.255.0

set ports range=9 dev=min
set line range=9 baud=115200
set flow range=9 ixon=off ixoff=off
  rts=on cts=on..... (1)

set radius primary=190.250.150.11 run=on
  secret=sammy1 ..... (2)
```

Configuration Notes

1. The `set ports`, `set line` and `set flow` commands configure port 9 for incoming modem connections using RTS/CTS flow control.
2. The `set radius` command configures PortServer II to use a RADIUS server.

PPP Dial-In Connection Without RADIUS

Introduction

In this configuration, PortServer II provides a dial-in PPP connection. It does not use a RADIUS server, but does configure an IP address pool.

Related Information

For more information on configuring

- Modem connections, see Chapter 7
- PPP connections, see Chapter 8
- IP pools, see the `set ippool` command in the *PortServer II Command Reference*.

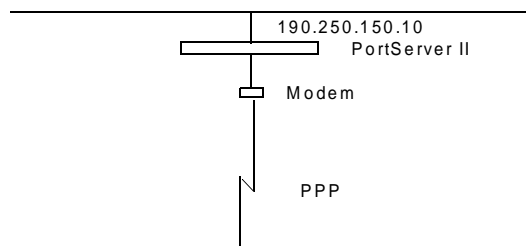

Configuration

```
set config ip=190.250.150.10
  submask=255.255.255.0

set ports range=9 dev=min
set line range=9 baud=115200
set flow range=9 ixon=off ixoff=off
  rts=on cts=on ..... (1)

set ippool count=3 ip=190.250.150.11 ..... (2)

set user name=PPP1 protocol=ppp mtu=1500
  ipaddr=ippool pppauth=none
  defaultaccess=netSERVICE
  netSERVICE=on compression=vj ..... (3)
```

Configuration Notes

1. The `set ports`, `set line` and `set flow` commands configure port 9 for incoming modem connections using RTS/CTS.
2. The `set ippool` command configures an IP address pool for remote PPP users.
3. The `set user` command configures attributes of the PPP connection.

Frame Relay Connection

Introduction

In this configuration, PortServer II provides a connection over a frame relay network.

Related Information

For information on configuring frame relay connections, see Chapter 9.

Illustration

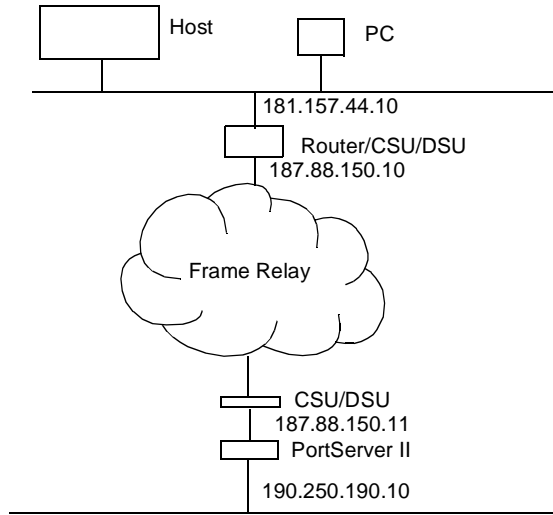

Configuration

```
set config ip=190.250.190.10
  submask=255.255.255.0

set framerelay lmi=lmirev1 mtu=1500 range=16
  enable=on .....(1)

set frdlci dlci=18 port=16 cir=28000 be=28000 .....(2)

set user name=frame frdlci=18 frport=16
  protocol=frame ipaddr=187.88.150.10
  ipmask=255.255.255.0 dialout=on .....(3)

set ports range=16 dev=prn .....(4)

set line range=16 baud=56000

set flow range=16 ixoff=off ixon=off .....(5)
```

Configuration Notes

1. The `set framerelay` command specifies the following:
 - The LMI scheme
 - The MTU
 - The port to use for the frame relay connection
 - `enable=on`
2. The `set frdlci` field defines virtual circuit attributes.
3. The `set user` command specifies the
 - IP address of the remote peer (on the `ipaddr` field)
 - `protocol=frame`
 - `dialout=on`
4. The `set ports` command specifies `dev=prn`, which is the device type for frame relay ports.
5. On the `set flow` command, all flow control fields must be `off`. Fields `ixoff` and `ixon` are explicitly turned off in the example.

Dial-In PPP Connection and Proxy ARP

Introduction

In this example, PortServer II performs Proxy ARP services for a PC located across a PPP link.

Related Information

For more information on configuring

- PPP connections, see Chapter 8
- Proxy ARP, see Chapter 10

Illustration

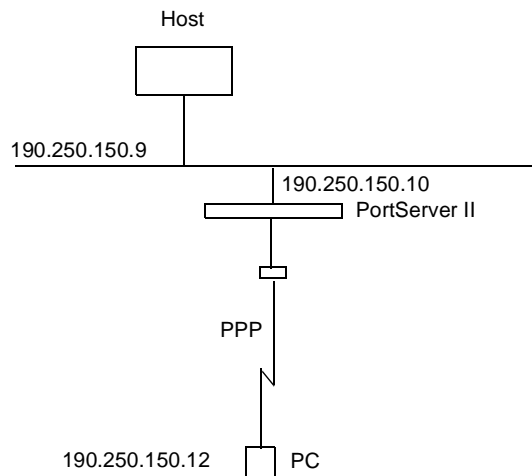

Configuration

```
set config ip=190.250.150.10
  submask=255.255.255.0
set ports range=9 dev=min
set line range=9 baud=115200
set flow range=9 ixon=off ixoff=off
  rts=on cts=on..... (1)

set user name=user1 protocol=ppp mtu=1500
  defaultaccess=netSERVICE netSERVICE=on
  ipaddr=190.250.150.12 compression=vj
  pppauth=none ..... (2)
set forwarding state=active proxyarp=on ..... (3)
```

Configuration Notes

1. The `set ports`, `set line` and `set flow` commands configures port 9 for an incoming modem connection.
2. The `set user` command configures attributes of the PPP connection.
3. The `set forwarding` command specifies `proxyarp=on`.

chapter **3**

**Configuring the
Ethernet Interface**

Introduction

This chapter discusses how to configure PortServer II's Ethernet connection. It discusses the following topics:

- Configuring an IP Address and Mask3-2
- Configuring a Default Gateway3-3

Configuring an IP Address and Mask

- Introduction** This section discusses how to assign an IP address and mask for PortServer II's Ethernet connection, which can be accomplished either by manual configuration or through the services of a RARP (reverse address resolution protocol) server, if one is operating on the LAN.
- Related Information** For more information on the `set config` command, see the *PortServer II Command Reference*.
- Starting Point** These procedures assume that you have logged in as root.
- Manual Configuration Procedure** Issue a `set config` command that specifies the following:
- An IP address on the `ip` field
 - An IP mask on the `submask` field
- Manual Configuration Example** In this example the `set config` command assigns an IP address and mask to the PortServer II Ethernet connection.
- ```
set config ip=192.150.150.10
submask=255.255.255.0
```
- RARP Server Procedure**
1. Ensure that the PortServer II is cabled to the Ethernet network.
  2. Ensure that the PortServer II IP address and hardware address mappings are included in the RARP server's tables.
  3. Switch the PortServer II's power on.  
PortServer II receives its IP address from the RARP server.
  4. Verify the configuration by attempting to establish a telnet or rlogin session over the Ethernet connection.

## Configuring a Default Gateway

- Introduction*** This section describes how to configure PortServer II to use the services of a default gateway. A default gateway is a router to which stations on the LAN send datagrams destined for hosts to which they do not have routes.
- Starting Point*** This procedure assumes that you are logged in as root.
- Procedure*** Issue a `set config` command that specifies the IP address of the default gateway on the `gateway` field.
- Example*** In this example the `set config` command configures PortServer II to use a default gateway.
- ```
set config gateway=192.150.150.12
```

chapter **4**

**Configuring
RealPort Connections**

In This Chapter

This chapter describes how to configure PortServer II for RealPort connections. It discusses the following topics:

- About RealPort4-2
- Configuring PortServer II for RealPort4-3

About RealPort

Introduction

This section provides a brief introduction to RealPort.

What is RealPort?

RealPort is a feature that allows LAN-based host systems to use the ports of the PortServer II as though they were the host system's own ports, appearing and behaving as local ports to the LAN-based host.

RealPort Advantages

RealPort provides the following advantages:

- It expands the number of ports available to the host system.
- It enables PortServer II ports to be treated as if they were directly connected to the host, which means they use all standard operating system interfaces that control baud rate, parity, stop bits, and flow control.
- It enables host administrators to do most of the required configuration on the host, the system with which the administrator is most familiar.
- It dramatically reduces host CPU overhead because multiple terminal or printer sessions are multiplexed over the same TCP/IP connection.

Configuring the RealPort Software

You must install and configure RealPort software on each host that will use RealPort ports. See the RealPort documentation for more information.

Configuring PortServer II for RealPort

- Introduction** This section describes how to configure PortServer II to provide LAN-based servers with RealPort ports.
- Related Information** See the appropriate RealPort manual for information on configuring the server.
- Starting Point** This procedure assumes that you have signed on as root and have or will
- Install RealPort software on each LAN-based host that will use RealPort ports and then properly configured RealPort software. See the appropriate RealPort documentation for more information.
 - Properly cabled PortServer II ports and devices
 - Set up the devices connected to PortServer II ports
- Procedure**
1. Configure the RealPort TCP port by specifying `set config realport=771`.
 2. Configure PortServer II ports by supplying a `set ports` command that specifies the following:
 - The range of ports to configure for RealPort (on the `range` field)
 - `dev=prn`
 3. If you want to reserve certain ports for a specific RealPort host, supply a `set auth` command that specifies the following:
 - The IP address of the host (on the `ip` field)
 - The range of ports to be reserved (on the `realport` field)
- Example** In this example, all of PortServer II ports are configured for RealPort. Ports 1 through 8 are reserved for one RealPort host and ports 9 through 16 are reserved for another.
- ```
set config ...realport=771
set ports range=1-16 dev=prn
set auth ip=199.250.225.10 realport=1-8
set auth ip=199.250.225.11 realport=9-16
```



*chapter* **5**

**Configuring  
Printer Connections**

***In This Chapter***

This chapter describes how to configure PortServer II ports for printer connections. It discusses the following topics:

- Configuration Considerations . . . . .5-2
- Configuring Printer Connections . . . . .5-4
- Configuring a Port for Direct-Access Printing . . . . .5-5

## Configuration Considerations

### *Introduction*

You should be aware of the following considerations if you intend to configure PortServer II to handle printers.

### *Determining Your Printer's Flow Control Requirements*

If you set the PortServer II flow control parameters incorrectly, the printer may not print all data sent to it. Consequently, before you configure a PortServer II port for a printer, check the printer's documentation to determine if it uses hardware flow control, software flow control, or no flow control at all.

### *Flow Control Tips*

Here are some tips to ensure that your printer performs as expected:

- For printers that do not use flow control, you do not need to supply a `set flow` command to define the printer's connection to PortServer II.
- If flow control is necessary, ensure that the printer and PortServer II use the same flow control scheme.
- Most printers that use hardware flow control issue the DTR (data terminal ready) signal when they are ready for data. If so, the DTR pin on the cable from the printer must be wired to an input on the PortServer II port (usually CTS or DCD) that can be used for flow control.

### *Printing with AIX Systems*

Digi does not recommend printing multiple jobs using `lpd` to a PortServer II-attached printer from an AIX print spooler because this may cause the print job to time out.

### *Using the lpd Protocol*

Here are some tips for configuring the print spooler on your Unix system when you intend to print using the `lpd` protocol to a printer attached to PortServer II:

1. The number of copies option with `lpr` is not supported.
2. Banner pages are not supported.
3. Give the PortServer II's DNS name or IP address as the remote system's name.
4. Specify a queue name that conforms to the following conventions:
  - Begin the queue name with one of the following character strings: (a) Use `ascii` if you want PortServer II to substitute carriage return and line feed characters for each line feed the system sends. (b) Use `raw` if no substitution should be performed.
  - After the queue name, insert an underscore character and the number of the PortServer II port to which the printer is attached.
  - If you want to use either of the following options, specify an additional underscore and then the letter that identifies the option: (a) Use `f` to append a form feed character to the end of

each file in a print job (b) Use `d` to add a Ctrl-d to the end of each file in a print job. (This is often required by PostScript printers.)

### Examples

| String                 | Result                                                                                 |
|------------------------|----------------------------------------------------------------------------------------|
| <code>ascii_1</code>   | Prints to port 1 and translates CR to CR/LF.                                           |
| <code>ascii_8_f</code> | Prints to port 8, translates CR to CR/LF and prints a form feed at the end of the job. |
| <code>raw_1_d</code>   | Prints to port 1 with no translation and appends a Ctrl-d to the end of the print job. |

### *Tips for telnet and rsh Printing*

Here are some tips for handling telnet and rsh printing:

- If line feed and carriage return problems occur, try supplying a `set line` command that specifies `onlcr=on`. This converts carriage returns to carriage return/line feeds.
- If you want tab characters (ASCII character 9) converted to 8 spaces, use a `set line` command that specifies `otab=on`.

## Configuring Printer Connections

**Introduction** This section describes how to configure PortServer II for printer connections.

**Related Information** See the discussions on the `set ports`, `set line`, and `set flow` commands in the *PortServer II Command Reference*.

**Starting Point** This procedure assumes the following:

- That you are logged in as `root`
- That you know the attributes, such as baud rate and parity, of the printer

**Configuration Procedure**

1. Configure the port for a printer by supplying a `set ports` command that specifies the following:
  - The port to which the printer is connected (on the `range` field)
  - `dev=prn`
2. Configure line attributes with a `set line` command. The attributes you configure will depend on your printer's requirements. See the description of the `set line` command in the *PortServer II Command Reference* to determine which of the `set line` command fields you require.
3. Configure flow control attributes of the connection with the `set flow` command. The attributes you configure will depend on your printer's requirements. See the description of the `set flow` command in the *PortServer II Command Reference* to determine which of the `set flow` command fields you require.

**Configuration Example** In this example, port 6 is configured for a printer that uses hardware flow control.

```
set ports range=6 dev=prn
set line range=6 baud=9600 csize=8 stopb=1
 parity=n
set flow range=6 cts=on ixon=off ixoff=off
```

## Configuring a Port for Direct-Access Printing

### *Introduction*

Direct access printing allows telnet users on the LAN to access a port and to issue print commands directly to the printer. This section describes the two ways users can access a printer directly and explains how to configure the port to support each method.

### *Method 1: Specifying Port Numbers in the Telnet Command*

This method allows users to issue telnet commands that identify the correct port by using TCP port numbers. Users identify the type of connection and port number by specifying one of the following:

| For this connection type... | Identify the port by specifying...                                                                                                                                 |
|-----------------------------|--------------------------------------------------------------------------------------------------------------------------------------------------------------------|
| Telnet                      | <ul style="list-style-type: none"><li>• 200 and then the port number for ports 1 through 9</li><li>• 20 and then the port number for ports 10 and higher</li></ul> |
| Raw                         | <ul style="list-style-type: none"><li>• 210 and then the port number for ports 1 through 9</li><li>• 21 and then the port number for ports 10 and higher</li></ul> |

### **User Command Example 1**

In this example, a user specifies a standard telnet connection on port 8 of a PortServer II using IP address 199.250.38.15.

```
cat myfile | telnet 199.250.38.15 2008
```

### **User Command Example 2**

In this example, a user specifies a raw telnet connection on port 8 of a PortServer II using IP address 199.250.38.15.

```
cat myfile | telnet 199.250.38.15 2108
```

**Note:** To specify a hunt group in the command instead of an individual port, use the group number specified on the `group` field of the `set ports` command that configured the port.

### *Method 1 Configuration*

There is no special configuration required to set up a port for this type of direct access. Simply configure the port for a printer. See *Configuring Printer Connections* on page 5-4 for more information.

### *Method 2: Using Alternate IP Addresses*

This method provides similar functions to method 1, but it differs in two ways:

- Alternate IP addresses allow users to identify both the PortServer II and a specific port by simply specifying an IP address.

- Alternate IP addresses cannot be used with raw connections.

#### **User Command Example**

In this example, a user again accesses a port on the PortServer II. Note that only an IP address identifies both the PortServer II and the serial port to access.

```
cat myfile | telnet 199.250.38.15
```

#### ***Method 2 Configuration***

To configure an alternate IP address, do the following:

- Configure the port for a printer. See *Configuring Printer Connections* on page 5-4 for more information.
- Supply a `set altip` command that specifies the following:
  - The port to which the printer is attached (on the `group` field)
  - The IP address to assign (on the `ip` field)

#### **Example**

```
set ports range=6 dev=prn
set line range=6 baud=9600 csize=8 stopb=1
 parity=n
set flow range=6 cts=on ixon=off ixoff=off
set altip group=6 ip=199.250.38.15
```

*chapter* **6**

**Configuring  
Terminal and  
Computer Connections**

***Introduction***

This chapter describes how to configure PortServer II ports for terminal and computer connections. It discusses the following topics:

- Configuring Terminal Connections.....6-2
- About Computer Connections.....6-4

## Configuring Terminal Connections

- Introduction** This section describes how to configure PortServer II ports for terminal connections.
- Port Defaults** Terminal connections with the following parameters are the default configuration for PortServer II ports.
- VT-100 emulation
  - 9600 baud
  - 8-bit characters
  - 1 stop bit
  - No parity
  - Software flow control
- Related Information**
- For information on the `set line`, `set ports`, and `set flow` commands, see the *PortServer II Command Reference*.
  - For information on configuring terminal ports for autoconnections, see, Chapter 13.
- Starting Point** This procedure assumes the following:
- That you are logged in as `root`
  - That you know the attributes, such as baud rate and parity, of the terminal that will be connected to this port
- Procedure**
1. Supply a `set ports` command that specifies the following:
    - The ports to which this command applies (on the `range` field)
    - `dev=term`
    - The number of simultaneous sessions the port user can maintain (on the `sess` field)
    - The terminal type (on the `termttype` field)
  2. Supply a `set line` command that specifies the following:
    - The ports to which this command applies (on the `range` field)
    - The baud rate for this line (on the `baud` field)
    - The character size to use on this line (on the `csize` field)
    - The parity scheme to use on this line (on the `parity` field)
    - The number of stop bits to use (on the `stopb` field)

3. If your terminal uses hardware flow control, supply a `set flow` command that specifies the following (software flow control is the default, so a `set flow` command is not required in that case):
  - The ports to which this command applies (on the `range` field)
  - `ixoff=off`
  - `ixon=off`
  - The flow control scheme required by your terminal. See the `set flow` command in the *PortServer II Command Reference* for more information.

***Example***

In this example, port 2 and 3 are configured for connection to terminals using hardware flow control. The connection uses default for character size (8 bits), parity (no parity), and stop bits (1).

```
set ports range=2-3 sess=3 dev=term term-
type=wy60

set line range=2-3 baud=19200

set flow range=2-3 ixon=off ixoff=off rts=on
cts=on
```

## About Computer Connections

### *Introduction*

Configuring computer connections is very similar to configuring terminal connections, which is discussed on page 6-2. Consequently, this section simply discusses the differences between these connection types.

### *Starting Point*

This section assumes that

- You are logged in as root
- You know the attributes, such as baud rate and parity, of the PC that will be connected to this port

### *Configuring Typical PC Connections*

To configure a port for a directly-connected PC, where the PC always initiates the connection, configure the connection as you would a terminal connection, except do the following:

- On the `set ports` command, specify `dev=min`, if you have a 10-pin null modem cable to support this type of connection. Use `dev=term` if you do not.
- Consider defining the serial connection as a PPP link. See Chapter 8 for more information.

### **Example**

This example configures a directly-connected PC using PPP.

```
set ports range=4 dev=min
set line range=4 baud=19200
set flow range=4 ixon=off ixoff=off
 rts=on cts=on
set ippool count=2 ip=199.230.14.19
set user name=PPP1 protocol=ppp mtu=1500
 ports=4 ipaddr=ippool pppauth=none
```

### ***Non-TCP/IP Host Connection***

To configure a non-TCP/IP host connection, configure the connection as you would a terminal connection (discussed on page 6-2) except do the following:

- On the `set ports` command, specify `dev=host`. If you want to specify a hunt group of ports, provide a group number on the `group` field as well.
- On the `set altip` command specify an IP address for the serial ports connected to the BBS host (on the `ip` field). If you defined a hunt group on the `set ports` command, specify an IP address for the group, by identifying the group on the `group` field.

### **Other Considerations**

You may want to set up the terminal and modem ports used to access the PortServer II as autoconnect ports, enabling port users to automatically connect to the BBS. See Chapter 13 for information.

### **Example**

In this example, ports 2-12 are set up for a BBS host.

```
set ports range=2-12 dev=host group=70
set line range=2-12 baud=19200
set flow range=2-12 ixon=off ixoff=off
 rts=on cts=on
set altip group=70 ip=199.179.23.10
```



*chapter* **7**

**Configuring  
Modem Connections**

***Introduction***

This chapter describes how to configure PortServer II ports for modem connections. It discusses the following topics:

- Tips on Configuring Your Modem . . . . . 7-2
- Configuring Incoming-Only Modem Connections . . . . . 7-3
- Configuring Outgoing and Bi-Directional Modem Connections . . . . . 7-5

**Note:** If you want to set up a port for a modem connection using RealPort, see Chapter 4.

**Note:** If you want to set up a port for a modem connection using CU and UUCP, see Appendix A.

## Tips on Configuring Your Modem

### *Introduction*

This section provides tips on configuring your modem to work with PortServer II.

### *Tips*

Here are some tips on configuring modems to work with PortServer II:

- Configure the modem so that DCD goes high when it receives an incoming connection request.
- Configure the modem to answer an incoming call only when DTR is high, and to drop the line when DTR goes low.
- For bidirectional connections, it is advisable to configure the non-volatile parameters in the modem for incoming calls. Also configure the modem to reset to these parameters when DTR is dropped.
- Configure the modem to lock the serial line speed at the highest baud rate the modem will accept for reliable data transfer because PortServer II cannot switch the baud rate of the serial line on a per call basis without reconfiguration.
- To check for correct modem operation, monitor the LEDs on the front panel of PortServer II to ensure the following:
  - That DCD is off when the modem is not connected
  - That the modem does not answer a call when DTR is low
  - That the modem hangs up when DTR is dropped

## Configuring Incoming-Only Modem Connections

### ***Introduction***

This section describes how to configure incoming-only modem connections, that is, connections that are initiated by a device across the telephone network.

### ***Related Information***

- If you intend to run SLIP or PPP traffic over this modem connection, see Chapter 8.
- For more information on setting the port's flow control attributes see the `set flow` command in the *PortServer II Command Reference*.
- For information on setting up the port for autoconnection, see Chapter 13 of this manual and the `set ports` command in the *PortServer II Command Reference*.
- For information on setting serial line operating parameters such as character size, the number of stop bits, and parity, see the `set line` command in the *PortServer II Command Reference*.

### ***Starting Point***

This procedure assumes that you

- Know the operating parameters required by the modem. If you do not, see the modem documentation.
- Have or will correctly cable the connection between the PortServer II serial ports and modems. See the *PortServer II Hardware Installation Guide* for more information.
- Logged in as root

### ***Procedure***

1. Supply a `set ports` command that specifies the following:
  - The serial port to which this command applies (on the `range` field)
  - `dev=min`
2. Supply a `set line` command that specifies the following:
  - The serial port to which this command applies (on the `range` field)
  - The line speed of the connection between the modem and the serial port (on the `baud` field)
3. Supply a `set flow` command that defines the flow control scheme required by the modem.

***Example***

In this example, ports 4 and 5 are set up for incoming modem connections using RTS/CTS flow control.

```
set ports range=4-5 dev=min
set line range=4-5 baud=115200
set flow range=4-5 ixon=off ixoff=off cts=on
 rts=on
```

## Configuring Outgoing and Bi-Directional Modem Connections

### ***Introduction***

This section describes how to configure outgoing and bidirectional modem connections.

### ***Related Information***

- For more information on setting the port's flow control attributes see the `set flow` command in the *PortServer II Command Reference*.
- For information on setting up the port for autoconnection, see Chapter 13 of this manual and the `set ports` command in the *PortServer II Command Reference*.
- For information on setting serial line operating parameters such as character size, the number of stop bits, and parity, see the `set line` command in the *PortServer II Command Reference*.
- For more information on configuring dialer and login scripts, see the `set script` command in the *PortServer II Command Reference*.
- If you intend to run SLIP or PPP traffic over this modem connection, see Chapter 8.

### ***Starting Point***

This procedure assumes that you

- Know the operating parameters required by the modem. If you do not, see the modem documentation.
- Have or will correctly cable the connection between the PortServer II serial ports and modems. See the *PortServer II Hardware Installation Guide* for more information.
- Logged in as root

### ***Procedure***

1. Supply a `set ports` command that specifies the following:
  - The serial port to which this command applies (on the `range` field)
  - Either `dev=mout` (for outgoing-only connections) or `dev=mio` (for bidirectional connections)
  - A group number (on the `group` field), if you intend to create a hunt group of ports that can access a pool of modems. Make sure this group number is greater than 65.
2. Supply a `set line` command that specifies the following:
  - The serial port to which this command applies (on the `range` field)
  - The line speed of the connection between the modem and the serial port (on the `baud` field)
3. Supply a `set flow` command that defines the flow control scheme required by the modem.

***Example***

In this example, ports 4 and 5 are configured for bidirectional modems.

```
set ports range=4-5 dev=mio
set line range=4-5 baud=115200
set flow range=4-5 ixon=off ixoff=off
 rts=on cts=on
```

*chapter* **8**

**Configuring PPP  
and SLIP Connections**

***In This Chapter***

This chapter discusses how to configure PPP and SLIP connections and the filters that can be used to initialize and manage them. It covers the following topics:

- Configuring PPP Connections . . . . . 8-2
- Configuring SLIP Connections . . . . . 8-6
- Introduction to Filters for PPP and SLIP Connections 8-8
- Filtering Criteria . . . . . 8-9
- Filtering Rules . . . . . 8-10
- Filter Examples . . . . . 8-11

## Configuring PPP Connections

**Introduction** This section discusses how to configure dial-in and dial-out PPP connections. It describes how to configure required attributes and common options. For information on fine-tuning PPP connections, see the description of the `set user` command in the *PortServer II Command Reference*.

**Related Information** See the `set user` command in the *PortServer II Command Reference*.

## Configuring Dial-In Connections

**Introduction** This section describes how to configure dial-in connections. Use it to configure dial-in only connections or to configure the inbound portion of a bidirectional connection.

**Starting Point** This procedure assumes the following:

- That you have logged in as root
- Defined the port for connection to either a modem or a directly-connected computer
- Configured an IP address pool if you intend to use one with this PPP connection. See the `set ippool` command in the *PortServer II Command Reference* for more information.

**Procedure** To configure inbound PPP connections, supply a `set user` command to define connection attributes. Use the following information to help you determine which `set user` command fields are required for your configuration.

1. All PPP dial-in configurations require that the `set user` command supply the following:
  - A user name (on the `name` field)
  - `protocol=ppp`
  - An IP address and mask to identify the remote peer (on the `ipaddr` and `ipmask` fields). This address can be one of the following:
    - A standard IP address in dotted decimal format
    - An address supplied by the peer (specify `ipaddr=0.0.0.0`)
    - An address from an IP address pool (`ipaddr=ippool`)
  - `defaultaccess=netservice`
  - `netservice=on`
  - Information on the type of PPP authentication to use.
    - For no authentication, specify `pppauth=none`.

- For PAP authentication, specify `pppauth=pap` and then supply a PAP user ID (on the `papid` field) and a PAP password (on the `pappasswr` field)
  - For CHAP authentication, specify `pppauth=chap` and then a CHAP ID (on the `chapid` field) and password (on the `chapkey` field)
  - For both PAP and CHAP authentication, specify `pppauth=both` and then supply both PAP and CHAP IDs and passwords.
2. To implement address compression, make sure that the `set user` command specifies `addrcompress=on`.
  3. To implement Van Jacobsen Header compression, make sure that the `set user` command specifies `compression=vj`.
  4. To implement protocol compression, make sure that the `set user` command specifies `protocompress=on`.
  5. If the PPP link is to a router and RIP is used to maintain routing tables, make sure that the `set user` command specifies how RIP updates are to be handled over the link (on the `netrouting` field). You can specify `off`, `send`, `receive`, or `both`.

***Configuration Example***

This example configures an incoming PPP connection that uses an IP address pool, Van Jacobsen Header Compression, and no authentication.

```
set user name=PPP1 protocol=ppp mtu=1500
 ipaddr=ippool pppauth=none
 defaultaccess=net service net service=on
 compression=vj
```

## Configuring Dial-Out Connections

- Introduction** This section describes how to configure dial-out PPP connections. Use it to configure dial-out only connections or to configure the outbound portion of a bidirectional connection.
- Starting Point** This procedure assumes that you have
- Logged in as root
  - Defined the port for connection to either a modem or a directly-connected computer
- Procedure**
1. Supply a `set script` command to configure a dialer script for the modem and another `set script` command to configure a login script. See the `set script` command in the *PortServer II Command Reference* for more information.
  2. Supply a `set device` command that specifies the following:
    - a name for the device (on the `name` field)
    - A reference to the name of the dialer script on the `dialer` field
    - The port that the device is to be associated with (on the `ports` field)
  3. If you want to configure a bringup filter that will bring the PPP link up only under certain conditions, supply a `set filter` command that defines the circumstances under which the link should be brought up. See the section on filters provided later in this chapter for more information.
  4. Supply a `set user` command to define outbound PPP connection attributes. The following are required to configure all PPP outbound connections:
    - A user name (on the `name` field)
    - `protocol=ppp`
    - An IP address and mask to identify the remote peer (on the `ipaddr` and `ipmask` fields).
    - `defaultaccess=netservice`
    - `netservice=on`
    - `dialout=on`
    - The name of the device created earlier (on the `device` field)
    - Information on the type of PPP authentication you want to use.
      - For no authentication, specify `pppauth=none`.
      - For PAP authentication, specify `pppauth=pap` and then supply a PAP user ID (on the `papid` field) and a PAP password on the (`papasswrđ` field)

- For CHAP authentication, specify `pppauth=chap` and then a CHAP ID (on the `chapid` field) and password (on the `chapkey` field)
  - For both PAP and CHAP authentication, specify `pppauth=both` and then supply both PAP and CHAP IDs and passwords.
5. To enable this link to use a bringup filter, make sure that the `set user` command specifies the name of the bringup filter on the `bringup` field. You may also want to configure the length of time the link should remain up when there is no traffic (on the `idle-timeout` field).
  6. To implement address compression, make sure that the `set user` command specifies `addrcompress=on`.
  7. To implement Van Jacobsen Header compression, make sure that the `set user` command specifies `compression=vj`.
  8. To implement protocol compression, make sure that the `set user` command specifies `protocompress=on`.
  9. If you configured a login script for this connection and used variables for the login ID and password, ensure that the `set user` command provides this information on the `p1` and `p2` fields.
  10. If you used a variable for the remote system's telephone number in the dialer script you configured, ensure that the `set user` command provides the telephone number on the `n1` field.
  11. If the PPP link is to a router and RIP is used to maintain routing tables, make sure that the `set user` command specifies how RIP updates are to be handled over the link (on the `netrouting` field). You can specify `off`, `send`, `receive`, or `both`.

**Configuration Example**

This example configures a dial-out PPP connection.

```
set script name=dialstd
 s1="M{atdt%n\r} [BUSY]* [CONNECT]+ S50 T="
set device name=netdev dialer=dialstd
 ports=9
set user name=user1 netservice=on defaultaccess=netservice protocol=ppp pppauth=none
set user name=user1 ipaddr=190.250.150.12
 ipmask=255.255.255.0
set user name=user1 loginscript=loginscript
 p1=fuzz p2=fuzz n1=555-1234
set user name=user1 device=netdev dialout=on
```

## Configuring SLIP Connections

- Introduction** This section discusses how to configure SLIP connections. It describes how to configure required attributes and common options. For information on fine-tuning SLIP connections, see the description of the `set user` command in the *PortServer II Command Reference*.
- Related Information** See the `set user` command in the *PortServer II Command Reference*.
- Starting Point** This procedure assumes the following:
- That you have created any filters you intend to use with this connection
  - That you have or will define the port for connection to either a modem or directly-connected computer
  - If this is an outgoing SLIP connection, you have defined a device or device pool. (See the `set device` command in the *PortServer II Command Reference*.)
  - That you have configured a dialer script for the modem and a login script to handle login and passwords on the peer. See the `set script` command in the *PortServer II Command Reference* for more information.
- Procedure** You configure a SLIP connection with a `set user` command. Use the discussion that follows to help you determine which `set user` command fields your configuration requires.
1. For all SLIP connections, specify the following:
    - a name for the connection (on the `name` field)
    - `protocol=SLIP`
    - A maximum transmission unit for this connection (on the `mtu` field). The default is `mtu=1500`.
    - The ports to which this configuration applies (on the `ports` field)
    - An IP address and mask for this connection's remote peer (on the `ipaddr` and `ipmask` fields).
  2. To configure an outgoing SLIP connection, specify:
    - The name of a device or device pool (on the `device` field). You must create the device (using the `set device` command) before referencing it on this command.
    - `outgoing=on`, which means that PortServer II can initiate outgoing connections
    - `dialout=on`
    - (Optional) The name of a bringup filter (on the `bringup` field),

which enables you to specify the conditions under which the connection is brought up. If you specify a bringup filter, you must

- Create the filter before referencing it on this command.
- Specify how long the connection can be inactive before it is to be shut down (on the `idletimeout` field). You may also want to specify the kind of traffic that constitutes an active connection. To do that specify a keepup filter on the `keepup` field. You must create this filter before referencing it on this command.

3. To configure incoming SLIP connections specify the following:
  - `netservice=on`
  - `defaultaccess=netservice`
4. To configure an IP address for PortServer II's end of this connection, which is usually not required, supply an address on the `localipaddr` field. If you do not specify an address, the IP address for PortServer II's ethernet interface is used.
5. To configure PortServer II to negotiate Van Jacobsen Header Compression, specify `compression=vj`. The default is `compression=none`.
6. To configure how this connection handles RIP routing packets (if active routing is configured) supply one of the following values on the `netrouting` field: `off`, `send`, `receive`, `both`. The default is `off`.

***SLIP Configuration Example***

This example configures an incoming SLIP connection.

```
set user name=slip1 protocol=slip mtu=1500
ipaddr=199.150.27.45 netservice=on
```

## Introduction to Filters for PPP and SLIP Connections

### *Purpose*

Filters are used to manage and control PPP and SLIP connections. You can design a filter to do any of the following:

- Bring up a connection
- Allow certain types of packets to use the connection and keep certain types of packets from using it
- Keep a connection up
- Send a message to the log file when a specified event occurs on the connection

### *Example*

You might, for example, develop a filter that brings up a connection on an outbound port only when PortServer II handles a packet carrying a particular destination IP address.

### *How a Filter Functions*

Fields on the `set user` command define how a filter functions, that is, whether it is the type of filter that accepts or blocks packets, brings up a connection, keeps up a connection, or sends a message to the log file. The following table describes each of the `set user` command fields related to filtering.

| set user Field | Description                                                           | Example                                                                                                                |
|----------------|-----------------------------------------------------------------------|------------------------------------------------------------------------------------------------------------------------|
| passpacket     | Causes a packet to be passed or blocked                               | Filter causes incoming packets from an IP address to be accepted and packets from all other IP addresses to be blocked |
| keepup         | Causes the idletimeout timer to be reset and a connection maintained. | Filter that causes the connection to be maintained as long as there is any packet traffic except RIP packets.          |
| bringup        | Causes the PortServer II to establish a connection.                   | Filter that causes an outgoing connection to be initiated whenever a packet specifying UDP is handled                  |
| logpacket      | Causes the PortServer II to send a message to the log file            | Filter that notifies the log anytime an ICMP packet is handled                                                         |

### *What Filters Contain*

Filters contain filtering criteria. That is, they specify the attributes of the packet upon which the filter will make decisions (whether to pass a packet or block it, whether to bring up a connection or not, etc.) Examples include IP addresses and whether the packet carries ICMP messages.

## Filtering Criteria

### *Introduction*

This section describes filtering criteria.

### *Filtering Criteria*

You can filter on the following elements in a packet:

- A name of a service (defined in the service table) that identifies a particular type of packet.
- The name of a host defined in the host table
- The number in an IP packet that identifies the protocol to which IP should pass the packet. Use one of the following: 1 for ICMP, 2 for IGMP, 6 for TCP, and 17 for UDP.
- An IP address or set of addresses
- TCP or UDP port numbers
- Incoming or outgoing packets
- Source or destination criteria, such as IP addresses, ports, and host names
- When the start of a TCP data stream is encountered. This option is always used with the `fin` option and is used to trigger logging (`logpacket` field on the `set user` command).
- TCP or UDP packets
- ICMP packets, which can be broken down further into the following types of ICMP packets:

| Packet Type                     | Type Identifier |
|---------------------------------|-----------------|
| Echo reply                      | 0               |
| Destination unreachable         | 3               |
| Source quench                   | 4               |
| Redirect                        | 5               |
| Echo request                    | 8               |
| Time exceeded for a datagram    | 11              |
| Parameter problem on a datagram | 12              |
| Timestamp request               | 13              |
| Timestamp reply                 | 14              |
| Address mask request            | 17              |
| Address mask reply              | 18              |

- **!** (exclamation), which means that if filter criteria is met, the action normally performed by this type of filter should **not** be performed.

# Filtering Rules

## *Introduction*

This section discusses the rules for creating filters.

## *Rules*

Here are a list of rules for creating filters:

- Filters are made up of 1 to 32 stanzas, each of which expresses filtering criteria.
- Stanzas are processed in order. That is, first S1 (stanza 1) is processed and then S2, and so on.
- As soon as a stanza's criteria is completely satisfied, filtering action occurs and subsequent stanzas are ignored. For example, if S1 specifies an IP address of 190.159.146.10 and an ICMP message type 7, a packet from that IP address carrying that ICMP message type will trigger filtering action. Subsequent stanzas will not be processed. Consequently, you must specify and relationships (all criteria must be satisfied) in the same stanza and or relationships (any of the criterion must be satisfied) in different stanzas.
- The exclamation mark (!) at the beginning of a stanza changes how the filter acts. When a packet is encountered that meets stanza criteria, the filter does **not** execute the filter function (for example, bringing up a connection).

## Filter Examples

### *Introduction*

This section provides examples of filters and the `set user` commands that define what type of actions the filters take when filter criteria is met.

### *Note on the Examples*

The `set user` commands in these examples are **not** sufficient to fully define a user for a PPP or SLIP connection. They have been simplified to illustrate the relationship between the `set filter` and `set user` commands.

### *Record ICMP Events in the Log File*

In this example, a message is sent to the log file anytime PortServer II handles an ICMP message.

- The `set filter` command defines a filter that uses ICMP messages as filtering criteria.
- The `set user` command references the filter on the name field and defines the filter as one that records ICMP activity in the log file.

```
set filter name=filter1 s1=icmp
set user name=tonik logpacket=filter1
```

### *Open a Connection for Certain IP Addresses*

In this example, PortServer II opens a connection whenever it handles packets destined for any of the IP addresses specified. Note that the `set filter` command specifies an or relationship. That is, a packet with a destination IP address that matches any of those listed will open a connection. Had these addresses been listed in the same stanza, an and relationship would have been specified, meaning a packet would have had to specify all of these IP addresses in the destination IP address field. Since this is not possible, a connection would never be opened.

```
set filter name=filter1 s1=dst/199.86.8.22
 s2=dst/199.86.8.27 s3=dst/199.86.8.54
set user name=garyg ipaddr=199.86.8.22
 bringup=filter1
set user name=dant ipaddr=199.86.8.27
 bringup=filter1
set user name=ronk ipaddr=199.86.8.54
 bringup=filter1
```

***Blocking Calls To  
a Subnet***

In this example, PortServer II blocks all calls to the subnet specified.

- The `set user` command defines this as the type of filter that allows packets to pass over the connection when they meet filtering criteria.
- The `set filter` command uses the exclamation point (!) to indicate that the normal filtering action for this type of filter should **not** occur.

```
set filter name=filter1 range=2-3
s1=!199.86.8.27 mask=255.255.255.0

set user name=router1 passpacket=filter1
```

***Filtering on Destination  
TCP Ports***

In this example, PortServer II brings up a connection when the destination TCP port is within the range specified.

```
set filter name=filter-port range=2
s1=tcp/20-25/dst

set user name=user1
bringup=filter-port
```

*chapter* **9**

**Configuring  
Frame Relay  
Connections**

***In This Chapter***

This chapter describes how to configure frame relay connections. It discusses the following topics:

- Planning Frame Relay Connections . . . . .9-2
- Frame Relay Configuration Procedure . . . . .9-3

## Planning Frame Relay Connections

### *Introduction*

This section provides planning information. It consists of two discussions: The first addresses planning steps, and the second discusses the information you must gather before you can configure a frame relay connection.

### *Planning Steps*

Here are some key frame relay planning steps:

1. Determine the locations you want to connect using frame relay.
2. Determine the traffic volume and patterns between locations. If frame relay replaces a leased or dial-up line, measuring actual traffic can be used to estimate bandwidth needs. Determining bandwidth needs is more difficult if these locations have not been linked before.
3. Determine the number of virtual circuits to use between locations.
4. Determine the committed information rate for each virtual circuit.

### *Information from Your Service Provider*

Gather and record the following information from your frame relay service provider:

- The LMI scheme used by the frame relay provider
- The line speed for each frame relay port
- The DLCIs to use to identify each virtual circuit
- The virtual circuits to pair to form a logical channel between locations
- The committed information rate (CIR) for each virtual circuit, which is the data rate the network guarantees
- The committed burst size (bcmax) for each virtual circuit, which is the data rate guaranteed by the network for short bursts. Some networks will not provide this parameter.
- The excess burst size, which is the maximum rate above the CIR that the network will allow you to transmit. Packets transmitted above the CIR will have the discard eligibility bit set, meaning they are likely candidates for discard should the network become congested.

### *Additional Information to Gather*

Gather the IP address of each remote peer.

## Frame Relay Configuration Procedure

- Introduction** This procedure describes how to configure PortServer II for frame relay connections.
- Related Information** See the descriptions of the `set framerelay` and `set frdlci` commands in the *PortServer II Command Reference*.
- Starting Point** This procedure assumes that you have
- Logged in as root
  - Gathered the configuration information described earlier in this chapter
- Procedure**
1. Configure the port or ports for frame relay using the `set framerelay` command. Specify the following:
    - An LMI scheme on the `lmi` field
    - An MTU size on the `mtu` field
    - The port to use on the `range` field
    - `enable=on`Usually you can use defaults for the remaining `set framerelay` command fields.
  2. Configure virtual circuits by supplying a `set frdlci` command for each one. Specify the following:
    - A DLCI (data link connection identifier) on the `dlci` field
    - The port or ports this command applies to on the `ports` field
    - A CIR on the `cir` field
    - Other `frdlci` fields as required by your service provider and your special circumstance.
  3. Configure a frame relay user for each virtual circuit (DLCI) with the `set user` command. (A user in this sense, is simply a set of attributes associated with the virtual circuit.) Specify the following:
    - A name for this user on the `name` field
    - A DLCI on the `frdlci` field
    - The port the DLCI is associated with on the `frport` field
    - `protocol=frame`
    - The IP address of the remote frame relay peer on the `ipaddr` field
    - The mask to apply to the remote frame relay peer's IP address on the `ipmask` field
    - `dialout=on`

You can also specify an IP address for the PortServer II side of the connection on the `localipadr` field. If you do not explicitly configure an IP address, the IP address for PortServer II's Ethernet interface is used.

4. Configure frame relay ports with the `set ports` command. Specify the following:
  - The port number on the `range` field
  - `dev=prn`
5. Configure flow control on frame relay ports with the `set flow` command that specifies that all flow control fields are off.:

***Example***

This example configures a frame relay connection.

```
set framerelay lmi=lmirev1 mtu=1500 range=2
 enable=on
set frdlci dlci=18 port=2 cir=28000 be=28000
set user name=frame1 frdlci=18 frport=2 protocol=frame
 ipaddr=199.86.8.190 ipmask=255.255.255.0
 dialout=on
set ports range=2 dev=prn
set flow range=2 ixoff=off ixon=off
```

*chapter* **10** **Configuring IP Routing**

***In This Chapter***

This chapter describes how to configure IP routing. It discusses the following topics:

- Introduction to Routing . . . . .10-2
- About RIP Routing Updates . . . . .10-3
- Configuring Static Routes . . . . .10-5
- Configuring Dynamic Routes Using RIP . . . . .10-7
- Configuring Proxy ARP . . . . .10-9

## Introduction to Routing

### *Introduction*

This section provides some introductory information on routing.

### *What is Routing*

Routing is the method, employed by IP software, of choosing a path over which to send packets between systems on different physical networks. When PortServer II is configured as a router, it performs this service.

### *Types of Routing*

PortServer II can be configured to perform the following types of routing:

- **Static routing.** When you use static routing, you manually configure routes to other networks for PortServer II. Static routing works fine for small, stable networks. Maintaining static routes is difficult on larger networks and on networks that experience a lot of changes.
- **Dynamic routing.** When you use dynamic routing, routes are not manually configured but are automatically established and maintained using information provided by routing information protocol (RIP). Route maintenance is obviously easier using RIP, but RIP has some shortcomings that are discussed later in this chapter.
- **Proxy ARP,** which is a technique in which a router answers ARP requests intended for another system. Typically, you use proxy ARP to move packets between physical networks that use the same IP network address. By pretending to be the other system, the PortServer II accepts responsibility for forwarding packets to that system. Proxy ARP makes routing decisions based on either static routes or on routing information provided by RIP.

## About RIP Routing Updates

### *Introduction*

RIP defines a method for propagating routing information among routers. It provides IP software with the information needed to make intelligent routing decisions.

The information, passed in RIP updates packets from router-to-router, consists of two items, a network ID and a hop count. A hop count is the number of routers through which a packet must pass on its way from a source to a destination network.

### *RIP Example*

In the example that follows, Router R1 “advertises” (using RIP) that it can reach Net 1 in one hop. When Router R2 receives this advertisement, it then knows that since it is on a common network with R1 that it can reach Net 1 in two hops. It advertises this fact to other routers in the network, who use this information to calculate their own routes to Net 1.

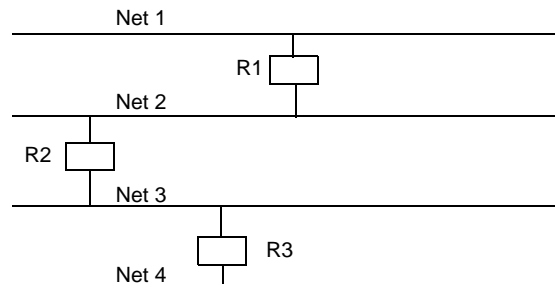

### *Problem with RIP: Sending Updates Across a WAN*

RIP can be an expensive way to handle routing if RIP updates are regularly sent across lines that charge by traffic volume or usage time. Neither of these, of course, applies to LANs or leased lines. Because of these cost considerations, PortServer II lets you turn RIP off on some or all serial links.

### *Problem with RIP: Slow Convergence*

Slow convergence is a problem that can arise from the method RIP uses to disseminate routing information. In the preceding figure,

1. R1 advertises that it can reach Net 1 in one hop.
2. R2 then advertises that it can reach Net 1 in two hops
3. R3 then advertises that it can reach Net 1 in three hops.

What happens if R1’s link to Net 1 goes down? First it realizes that its one-hop route to Net 1 is no longer available. But it hears that R2 can reach Net 1 in two hops, so it updates its routing table to say it can reach Net 1 in three hops, the one hop to R2 and the two hops R2 says it needs to reach Net 1.

R1 then advertises that it can reach Net 1 in three hops. R2 hears the

advertisement and realizes that if R1 needs three hops to get to Net 1 then it needs to update its own routing tables to reflect that fact, because it knows that its route to Net 1 is always one more hop than R1 requires. Consequently, it updates its routing tables to say that it can reach Net 1 in four hops. This can go on until the hop count to Net 1 reaches 16, which RIP defines as an unreachable destination.

***Combatting RIP's Slow Convergence Problem***

There are two methods to combat RIP's slow convergence problem, both of which PortServer II implements.

The first is called "split horizon," which stipulates that learned routes are **not** propagated from the interface on which they are learned. Had split horizon been used in the preceding example, R2 would not have advertised to R1 that it could reach Net 1. Consequently, R1 would never have regarded R2 as an alternate path to Net 1.

The second is called "poison reverse," which stipulates that routes are advertised as unreachable on the interface on which the route is learned. Had poison reverse been used in the preceding example, R2 would have advertised Net 1 as unreachable in its RIP updates to R1. Again R1 would never have regarded R2 as an alternate path to Net 1.

***PortServer II Participation in RIP Updates***

PortServer II's participation in the exchange of RIP updates can be configured on the `set forwarding` command. This command allows you to configure PortServer II

- To neither receive nor propagate RIP updates (`state=off`), which means it must be configured for static routes (`set route` command) if it is to do any routing at all.
- To receive RIP updates but not advertise its own routes using RIP (`state=passive`)
- To both receive and pass RIP updates (`state=active`)

## Configuring Static Routes

- Introduction** This section describes how to configure PortServer II for static routes.
- Related Information** See the `set route` command in the *PortServer II Command Reference*.
- Starting Point** This procedure assumes that you have or will configure modems, modem scripts, devices, and filters for routes that use serial lines.
- Procedure**
1. Configure the links over which routing and RIP updates will be sent.
  2. Configure a static route to every destination to which you want PortServer to route packets. Specify the following on the `set route` command:
    - The IP address and mask of the destination network on the `net` and `mask` fields
    - The number of hops to the destination network (on the `metric` field)
    - One of the following:
      - If the path to the destination network is across the LAN, specify the IP address of the router that is the next hop to the destination network (on the `gateway` field)
      - If the path to the destination network is through a serial port, specify the name of the `set user` command that defines the frame relay, PPP, SLIP, or CSLIP connection (on the `waname` field)

**Example: Static Routes**

In this example, which shows only those commands and command fields pertinent to routing, PortServer II is configured for two static routes.

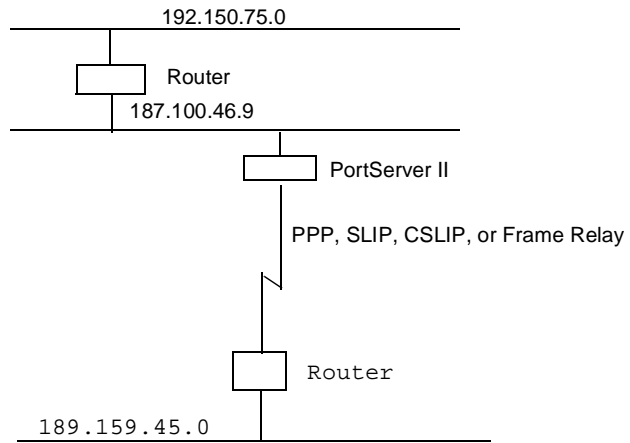

```
set route net=192.150.75.0 mask=255.255.255.0
 gateway=187.100.46.9 metric=1
set route net=189.159.45.0 wanname=link1 metric=1
set user name=link1 ...
```

## Configuring Dynamic Routes Using RIP

**Introduction** This section describes how to configure PortServer II for dynamic routing.

**Related Information** See the `set forwarding` command in the *PortServer II Command Reference*.

**Starting Point** This procedure assumes that you have sign on as root and have or will configure modems, modem scripts, devices, and filters for routes that use serial lines.

**Procedure** 1. Configure the links over which routed packets and RIP updates will be sent.

- To enable routing over the LAN to which PortServer II is attached or frame relay links, no routing-specific configuration is required.
- To enable routing over PPP, SLIP, or CSLIP links be sure to use the `netrouting` field on the `set user` command to configure how PortServer II handles RIP updates. You can configure the link so that PortServer II does any of the following with RIP updates:
  - Both sends and receives them (`netrouting=both`)
  - Sends them only (`netrouting=send`)
  - Receives them only (`netrouting=receive`)
  - Neither sends nor receives them (`netrouting=off`)

2. Configure the PortServer II for dynamic routing with a `set forwarding` command that specifies `state=active`.

You may also want to turn on the `poisonreverse` and `splithorizon` fields to prevent the RIP slow convergence problem discussed on page 10-3. See the discussion on the `set forwarding` command provided in the *PortServer II Command Reference* for more information.

***Example: Dynamic Routes***

In this example, which shows only those commands and command fields pertinent to routing, PortServer II is configured for dynamic routing using RIP. But to prevent RIP updates from being sent across the PPP link, the `set user` command that defines the link specifies `netrouting=off`.

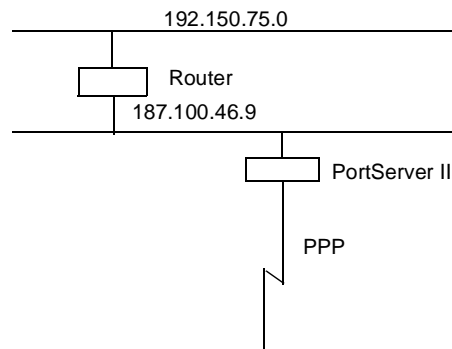

```
set forwarding state=active poisonreverse=on
splithorizon=on
set user name=link1 ...netrouting=off
```

## Configuring Proxy ARP

- Introduction** This section describes how to configure PortServer II for Proxy ARP.
- Related Information** See the `set forwarding` command in the *PortServer II Command Reference*.
- Starting Point** This procedure assumes that you have signed on as root and have or will configure modems, modem scripts, devices, and filters for routes that use serial lines.
- Procedure**
1. Configure the links over which packets will be routed using a `set user` command. This command must specify (on the `ipaddr` field) a specific IP address for the remote system using the Proxy ARP service.
  2. Configure PortServer II for Proxy ARP by supplying a `set forwarding` command that specifies the following:
    - `state=passive`
    - `proxyarp=on`
- Example** In this example, PortServer II provides Proxy ARP services to a remote host.

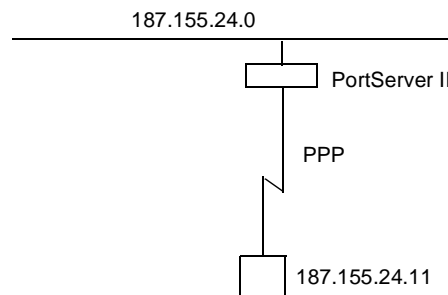

```
set user name=link1 ...ipaddr=187.155.24.11
set forwarding state=passive proxyarp=on
```



*chapter* **11**

**Configuring  
the SNMP Agent**

***Introduction***

This chapter describes how to configure the PortServer II SNMP agent. It discusses the following topics:

- About SNMP and the PortServer II Agent . . . . .11-2
- Configuration Procedure . . . . .11-4

## About SNMP and the PortServer II Agent

### *Introduction*

This section introduces SNMP and network management in TCP/IP networks, and it describes the PortServer II agent. It discusses the following:

- Network management components
- The SNMP agent
- SNMP traps
- The PortServer agent's MIB support
- The PortServer agent's supported traps

### *Network Management Components*

The TCP/IP network management architecture contains the following components:

- Managed nodes such as host systems, routers, terminal and communications servers (such as PortServer) and other network devices
- One or more network managers (also called network management stations), which are the points from which the network is managed
- Agents that reside on managed nodes and retrieve management information and communicate this information to network managers
- The network management protocol, SNMP, which governs the exchange of information between the nodes and stations
- Management information, which is the database of information about managed objects. This database is called the management information base (MIB).

### *SNMP Management Agent*

Each managed node contains at least one agent—a component that responds to requests from the network manager—that retrieves network management information from its node and notifies the manager when significant events occur.

### *SNMP Traps*

A mechanism defined by SNMP is called a trap, which is a report or “alarm” from a managed node to an SNMP manager that a significant event has occurred.

### *MIB Support*

The PortServer agent supports the following MIBs:

- MIB II (RFC 1213), which is an Internet-standard MIB, consisting of managed objects from the systems, interfaces, IP, ICMP, TCP, UDP, transmission, and SNMP group
- Character-based MIB (RFC 1316)
- RS-232-like MIB (RFC 1317)

***Message Support***

The SNMP agent supports the `Get`, `GetNext`, and `Trap` messages as defined in RFC 1157. These messages are used as follows:

- `Get`, which means retrieve the value of a specific object form one of the supported MIBs
- `GetNext`, which means retrieve the value of the next object in the MIB
- `Trap`, which means send traps to the manager when a particular type of significant event occurs

***Supported Traps***

The PortServer agents can send traps when any of the following:

- Cold starts (PortServer initializes)
- Authentication failures

***For More Information on Supported RFCs***

The RFCs mentioned in this section can be access at the following URLs:

| <b>RFC</b> | <b>URL</b>                                                                          |
|------------|-------------------------------------------------------------------------------------|
| 1157       | <a href="http://ds.internic.net/rfc/rfc1157">http://ds.internic.net/rfc/rfc1157</a> |
| 1213       | <a href="http://ds.internic.net/rfc/rfc1213">http://ds.internic.net/rfc/rfc1213</a> |
| 1316       | <a href="http://ds.internic.net/rfc/rfc1316">http://ds.internic.net/rfc/rfc1316</a> |
| 1317       | <a href="http://ds.internic.net/rfc/rfc1317">http://ds.internic.net/rfc/rfc1317</a> |

## Configuration Procedure

|                                     |                                                                                                                                                                                                                                                                                                                                                                                                                                                                                                                                                                                                                                                                                                                                                                                                                                                                                           |
|-------------------------------------|-------------------------------------------------------------------------------------------------------------------------------------------------------------------------------------------------------------------------------------------------------------------------------------------------------------------------------------------------------------------------------------------------------------------------------------------------------------------------------------------------------------------------------------------------------------------------------------------------------------------------------------------------------------------------------------------------------------------------------------------------------------------------------------------------------------------------------------------------------------------------------------------|
| <b><i>Introduction</i></b>          | This section describes how to configure PortServer's SNMP agent.                                                                                                                                                                                                                                                                                                                                                                                                                                                                                                                                                                                                                                                                                                                                                                                                                          |
| <b><i>Related Information</i></b>   | See the <code>snmp</code> command in the <i>PortServer II Command Reference</i> .                                                                                                                                                                                                                                                                                                                                                                                                                                                                                                                                                                                                                                                                                                                                                                                                         |
| <b><i>Starting Point</i></b>        | This procedure assumes that you have gather the following information: <ul style="list-style-type: none"><li>• The IP address of the manager to which traps are sent</li><li>• The name and location of the SNMP contact person</li><li>• The SNMP name of the PortServer you are configuring</li></ul>                                                                                                                                                                                                                                                                                                                                                                                                                                                                                                                                                                                   |
| <b><i>Procedure</i></b>             | Issue an <code>snmp</code> command to configure PortServer II's SNMP agent. Specify the following: <ul style="list-style-type: none"><li>• The IP address of an SNMP management station to which traps are to be sent on the <code>trap_dest</code> field</li><li>• A name for this PortServer II on the <code>snmp_name</code> field</li><li>• A description of where PortServer II is located on the <code>location</code> field. If there are spaces in this entry, enclose it in quotation marks.</li><li>• The name of an SNMP contact person on the <code>snmp_contact</code> field. If there are spaces in this entry, enclose it in quotation marks.</li><li>• Whether authentication traps are generated when an authentication error occurs on the <code>auth_trap</code> field</li><li>• Whether the SNMP agent should run immediately on the <code>run</code> field</li></ul> |
| <b><i>Configuration Example</i></b> | <pre>snmp auth_trap=on trap_dest=190.174.150.10 location="Digi Minnesota" snmp_name=blaze snmp_contact="bill jones" run=on</pre>                                                                                                                                                                                                                                                                                                                                                                                                                                                                                                                                                                                                                                                                                                                                                          |

# *chapter* 12

## **Configuring Security Features**

### ***In This Chapter***

This chapter describes PortServer II security features and discusses how to configure them. It presents the following topics:

- Controlling Access to the PortServer II Configuration . . .12-2
- Controlling Access to Inbound Ports . . . . .12-3
- Controlling Access to Outbound Ports . . . . .12-5
- Controlling Access to the PortServer II Command Line .12-6
- Using RADIUS to Authenticate Users . . . . .12-7
- Issuing User Passwords . . . . .12-8

## Controlling Access to the PortServer II Configuration

### *Introduction*

This section describes how to control access to the PortServer II configuration, which, of course, is a key to maintaining other aspects of security.

### *Root and Regular User Privileges*

PortServer II restricts access to the configuration by defining the following types of users:

- The root user, who has unlimited access to PortServer II commands. He or she can view any configuration table and change any configuration parameter. The root is identified by the user name `root` and must supply a password to be authenticated. The default root password is `dbps`. You should change this password immediately.
- Regular users, who have much more restricted access to PortServer II commands. Regular users can view some configuration tables and can change some configuration parameters related to their own sessions and passwords. See the *PortServer II Command Reference* for information on the limitations placed on regular users for each command.

## Controlling Access to Inbound Ports

### *Introduction*

This section describes methods of controlling access to inbound serial ports. An inbound port is one defined on the `dev` field of the `set ports` command for one of the following device types:

- `term` (used to define terminal connections)
- `min` (used to define incoming modem connections)
- `mio` (used to define bi-directional modem connections)
- `hdial, hio` (used to define computer connections)

### *Default Access Restrictions*

The default configuration for inbound ports is that a login and password are required to access them.

### *Options for Removing Access Restriction*

The login and password requirement for inbound ports can be changed by configuring

- The port so that it does not require a login and password. In this case, no one is required to supply a login or password.
- Specific users so that they do not require a password. In this case, some users do not supply passwords, and others may have to.

### *Procedure for Changing a Port's Access Requirements*

To configure a port so that no one has to login or specify a password, supply a `set logins` command that specifies the following:

- The port or ports configured by this command (on the `range` field)
- `login=off`
- `passwd=off`

**Example:** `set logins range=4-6 login=off passwd=off`

### *Procedure for Changing a User's Access Requirements*

To configure a user so that he or she does not have to specify a password when accessing an inbound port, supply a `set user` command that specifies the following:

- A name to identify the user (on the `name` field)
- `password=off`

**Example:** `set user name=user1 password=off`

***Access Restrictions for  
PPP and SLIP Users***

PPP and SLIP users can have their access to inbound ports restricted by

- Specific days and times
- Length of time

For more information on using these options, see the description of the `accesstime` and `sessiontimeout` fields of the `set user` command provided in the *PortServer II Command Reference*.

***PAP and CHAP  
Authentication for PPP  
Users***

PAP and CHAP authentication can be used to restrict PPP user access to inbound ports. For more information on PAP and CHAP configuration, see the `set user` command in the *PortServer II Command Reference*.

## Controlling Access to Outbound Ports

- Introduction** This section describes methods for controlling access to outbound serial ports. An outbound port is one defined on the `dev` field of the `set ports` command for one of the following device types:
- `prn` (used to define printer connections)
  - `mout` (used to define outbound modem connections)
  - `mio` (used to define bi-directional modem connections)
  - `host` (used to define host connections)
- Default Access** The default for outbound ports is unlimited access.
- Restricting Access to Outbound Ports** Use the `set auth` command to restrict access to outbound ports. See the description of the `set auth` command in the *PortServer II Command Reference* for more information.
- Access Restrictions for PPP and SLIP** PPP and SLIP users can have their access to outbound ports restricted by
- Specific days and times
  - Length of time
- For more information on using these options, see the description of the `accesstime` and `sessiontimeout` fields of the `set user` command provided in the *PortServer II Command Reference*.
- CHAP Authentication for PPP Users** CHAP authentication can be used to restrict PPP user access to outbound ports. For more information on CHAP configuration, see the `set user` command in the *PortServer II Command Reference*.

## Controlling Access to the PortServer II Command Line

### *Introduction*

This section describes how to restrict access to the PortServer II command line for those users who have been allowed access to a PortServer II serial port.

### *Method 1 Autoconnection*

The autoconnection feature allows you to configure a user to access the PortServer II but then be automatically connected to a host on the LAN.

You can implement autoconnection in the following ways:

- By port. In this case, all port users are automatically connected to the same host. The PortServer II is completely transparent to them.
- By user. In this case, a user is required to login and may be required to supply a password, but once the user is authenticated, an automatic connection to a hosts made.

For information on configuring autoconnection, see Chapter 13.

### *Method 2: Menus*

Menus select destination systems without having to access the PortServer II command line. For information on configuring menus, see the description of the `set menu` command in the *PortServer II Command Reference*.

## Using RADIUS to Authenticate Users

|                                     |                                                                                                                                                                                                                                                                                                                                                                                                                                                                                                                                                                                                                                                                                                                                                                                                                                                                                         |
|-------------------------------------|-----------------------------------------------------------------------------------------------------------------------------------------------------------------------------------------------------------------------------------------------------------------------------------------------------------------------------------------------------------------------------------------------------------------------------------------------------------------------------------------------------------------------------------------------------------------------------------------------------------------------------------------------------------------------------------------------------------------------------------------------------------------------------------------------------------------------------------------------------------------------------------------|
| <b>Introduction</b>                 | This section provides a description of RADIUS and explains how to configure PortServer II to use RADIUS.                                                                                                                                                                                                                                                                                                                                                                                                                                                                                                                                                                                                                                                                                                                                                                                |
| <b>What is RADIUS?</b>              | RADIUS (remote authentication dial-in user service) is a method of maintaining a database of profiles of dial-in users. These profiles can include login and password information, as well as other user attributes.                                                                                                                                                                                                                                                                                                                                                                                                                                                                                                                                                                                                                                                                    |
| <b>RADIUS Components</b>            | RADIUS requires two components, an authentication host server and client protocols. The PortServer II implements the client protocol. A host must implement the authentication server application.                                                                                                                                                                                                                                                                                                                                                                                                                                                                                                                                                                                                                                                                                      |
| <b>How RADIUS Works</b>             | Here is how authentication works when PortServer II is configured for RADIUS: <ol style="list-style-type: none"><li>1. A user logs into PortServer II.</li><li>2. PortServer II collects login information and then checks to see if the user is in the local database of users.</li><li>3. If the user is in the local database, PortServer II handles authentication.</li><li>4. If the user is <u>not</u> in the local database, PortServer II submits an authentication request to the RADIUS server.</li><li>5. The RADIUS server does one of the following:<ul style="list-style-type: none"><li>• If the user is validated, it passes this information to other devices and the user is permitted access.</li><li>• If the user is not validated, the RADIUS server returns an access reject message to PortServer II, which then denies access to the user.</li></ul></li></ol> |
| <b>Configuring RADIUS</b>           | To configure PortServer II to function as a RADIUS client, supply a <code>set radius</code> command that specifies the following: <ul style="list-style-type: none"><li>• <code>run=on</code></li><li>• The IP address of the primary RADIUS server (on the <code>primary</code> field). The primary server is the first server to which authentication requests are sent.</li><li>• A password (on the <code>secret</code> field)</li></ul>                                                                                                                                                                                                                                                                                                                                                                                                                                            |
| <b>Note:</b>                        | To use a secondary RADIUS server, supply a second <code>set radius</code> command that specifies <code>run=on</code> , the IP address of the secondary server (on the <code>secondary</code> field) and another password for the secondary server (on the <code>secret</code> field).                                                                                                                                                                                                                                                                                                                                                                                                                                                                                                                                                                                                   |
| <b>RADIUS Configuration Example</b> | <pre>set radius run=on primary=199.123.15.129 secret=J9CxeppP</pre>                                                                                                                                                                                                                                                                                                                                                                                                                                                                                                                                                                                                                                                                                                                                                                                                                     |

## Issuing User Passwords

|                            |                                                                                                                                                                                                                                                                                                                                                                                                         |
|----------------------------|---------------------------------------------------------------------------------------------------------------------------------------------------------------------------------------------------------------------------------------------------------------------------------------------------------------------------------------------------------------------------------------------------------|
| <i>Introduction</i>        | This section discusses how to issue user passwords.                                                                                                                                                                                                                                                                                                                                                     |
| <i>Related Information</i> | See the <code>newpass</code> and <code>set user</code> commands in the <i>PortServer II Command Reference</i> .                                                                                                                                                                                                                                                                                         |
| <i>Starting Point</i>      | This procedure assumes that you have signed on as root and already configured the user to whom you will be issuing a password.                                                                                                                                                                                                                                                                          |
| <i>Procedure</i>           | <ol style="list-style-type: none"><li>1. Issue a <code>newpass</code> command that identifies the user (on the name field) to whom this password will be issued.</li><li>2. When the system prompts you for a new password, type in the password and then press <b>Enter</b>.</li><li>3. When the system prompts you to enter the new password again, type it in and then press <b>Enter</b>.</li></ol> |
| <i>Example</i>             | <p>In this example, the <code>newpass</code> command initiates a dialog with PortServer II that results in the user being assigned a password.</p> <pre>newpass name=edm1001</pre>                                                                                                                                                                                                                      |

*chapter* **13**

**Configuring  
Autoconnection**

***Introduction***

This Chapter discusses how to configure the autoconnection feature. It covers the following topics:

- About Autoconnection . . . . .13-2
- Configuring Autoconnection By Port . . . . .13-3
- Configuring a User for Autoconnection . . . . .13-4

## About Autoconnection

### *Introduction*

This section describes the two autoconnection methods.

### *Autoconnection Methods*

The autoconnection feature allows you to configure a user to access the PortServer II but then be automatically connected to a host on the LAN. You can implement autoconnection in the following ways:

- By port. In this case, all port users are automatically connected to the same host. The PortServer II is completely transparent to them.
- By user. In this case, a user is required to login and may be required to supply a password, but once the user is authenticated, an automatic connection to a hosts made.

## Configuring Autoconnection By Port

- Introduction** This section describes how to configure a port for autoconnection.
- Starting Point** This procedure describes how to set up a port for autoconnection only. It assumes that you have or will configure the port appropriately for a modem connection (see Chapter 7) or terminal connection (see Chapter 6).
- Procedure** To configure a port to provide automatic connections for all port users, supply a `set ports` command that specifies the following:
- The ports configured for autoconnection (on the `range` field)
  - `auto=on`
  - The IP address of the host to which the autoconnection should be made (on the `dest` field)
  - The TCP port to use for this connection (on the `dport` field)
- Example** In this example, port 5 is configured for automatic telnet connections to a host.
- ```
set ports range=5 auto=on dest=199.125.123.10
dev=min dport=23
```

Configuring a User for Autoconnection

- Introduction** This section describes how to configure a user for autoconnection.
- Starting Point** This procedure deals with autoconnection features only. It assumes that you have or will configure
- The port for modem connections (see Chapter 7) or terminal connections (see Chapter 6)
 - Other user attributes (see the `set user` command in the `PortServer II Command Reference`)
- Procedure** To configure a user to automatically connect to a host, supply a `set user` command that specifies the following:
- A name for the user (on the `name` field)
 - The ports this user can use (on the `ports` field)
 - `autoconnect=on`
 - The IP address of the host to which the user should be connected (on the `autohost` field)
 - The TCP port to use for connects (on the `autoport` field)
 - `defaultaccess=autoconnect`
- Example** In this example, a user is configured for autoconnection using telnet to the host specified. Because the `password` field is not specified, the default (`password=on`) requires that the user supply a password before the connection is made.
- ```
set user name=user4 autoconnect=on auto-
host=199.193.150.10 autoport=23
defaultaccess=autoconnect
```

*chapter* **14**

**Configuring DNS**

***In this chapter***

This chapter discusses how to configure PortServer II to use DNS. Topics discussed include the following:

- About the Domain Name System .....14-2
- Configuration Procedures .....14-3

## About the Domain Name System

|                              |                                                                                                                                                                                                                                                                                                                                                                                                                                                                                                                                                                                                                                                                                                                                          |
|------------------------------|------------------------------------------------------------------------------------------------------------------------------------------------------------------------------------------------------------------------------------------------------------------------------------------------------------------------------------------------------------------------------------------------------------------------------------------------------------------------------------------------------------------------------------------------------------------------------------------------------------------------------------------------------------------------------------------------------------------------------------------|
| <i>Introduction</i>          | This section discusses key concepts of the domain name system.                                                                                                                                                                                                                                                                                                                                                                                                                                                                                                                                                                                                                                                                           |
| <i>Purpose of DNS</i>        | The domain name system maps domain names to information associated with these names, such as IP addresses.                                                                                                                                                                                                                                                                                                                                                                                                                                                                                                                                                                                                                               |
| <i>DNS Components</i>        | <p>DNS components include:</p> <ul style="list-style-type: none"><li>• A distributed database consisting of domain names and associated information</li><li>• A hierarchical system of domain name servers that maintain the database and use it to respond to requests for information about a particular domain name, such as its IP address</li><li>• Domain name resolvers that<ul style="list-style-type: none"><li>— Accept requests from users</li><li>— Satisfy information requests by building and submitting properly formulated queries to one or more name servers or by retrieving information from a local host file</li><li>— Return information to users</li><li>— Cache information for future use</li></ul></li></ul> |
| <i>Types of Name Servers</i> | <p>There are two types of name servers in the domain name system:</p> <ul style="list-style-type: none"><li>• Local servers maintain information for resources within a local zone. It is up to individual network administrators to determine the scope of a local zone.</li><li>• Root servers maintain information in higher-level domains than do local servers.</li></ul> <p>Typically, when a user requires information about a domain name, the resolver queries a local server. If local servers cannot provide the information, root servers are queried next.</p>                                                                                                                                                              |
| <i>Naming Conventions</i>    | Each node in the domain name system has a globally unique domain name that consists of its own name, which is called a label, and the labels of all superior nodes.                                                                                                                                                                                                                                                                                                                                                                                                                                                                                                                                                                      |
| <i>DNS Name Example</i>      | <p>Here is an example of a domain name. Note that labels are separated by periods:</p> <p><code>mn07.amalgamated.com</code></p> <p>In this example, <code>mn07</code> is part of the higher-level domain called <code>amalgamated.com</code>.</p>                                                                                                                                                                                                                                                                                                                                                                                                                                                                                        |

## Configuration Procedures

### Procedure for Using a Name Server

**Introduction** Use this procedure to use a name server to supply IP address-to-domain name mappings.

**Procedure** Issue a `set config` command that specifies the following:

- The name of PortServer II's domain on the `domain` field
- A DNS name for PortServer II on the `myname` field
- The IP address of a name server on the `nameserv` field

**Example**

```
set config domain=dgii.com myname=poe
nameserv=204.221.110.191
```

### Procedure for Using a Host File

**Introduction** Use this procedure to manually configure the host table, which PortServer II uses to map IP addresses to host names.

**Procedure** Issue a `set host` command for each host that you want included in the host table. Specify the following:

- The name of a host on the `name` field
- The IP address for the host on the `ip` field

**Example** In this example, three `set host` commands provide IP address-to-domain name mappings for three hosts.

```
set host name=poe ip=204.221.110.201
set host name=gary ip=204.221.110.202
set host name=toni ip=204.221.110.203
```



*chapter* **15**

**Managing the OS  
and Configuration**

***In This Chapter***

This chapter provides information on updating the operating system (OS) and managing the configuration. Topics include the following:

- Upgrading the OS . . . . .15-2
- Configuring PortServer II from a Remote Host . . . . .15-4
- Resetting the Configuration to Defaults . . . . .15-6

## Upgrading the OS

**Introduction** This section describes how to upgrade the PortServer II operating system (OS). The OS is stored in flash ROM and can be upgraded without changing the ROM or other hardware.

**Related Information** See the `boot` and `set config` commands in the *PortServer II Command Reference*.

**Starting Point** This procedure assumes that you have logged in as `root`.

**Procedure**

1. Obtain a copy of the latest PortServer II OS from the Digi International web site, `digi.com`, and copy it to a host running TFTP.
2. Configure the PortServer II to boot from the TFTP host by supplying a `set config` command that specifies the following:
  - The IP address of the TFTP host on the `boothost` field
  - The name of the file that holds the new OS on the `bootfile` field. This name may require the full path to the file. See the host's documentation for information.
  - `tftpboot=smart`, which means that if PortServer II cannot boot from the TFTP host, it will boot from the OS stored in flash ROM

3. Reboot PortServer II by supplying a `boot` command that specifies `action=reset`.

When the boot is complete, the PortServer II operates from the new OS.

4. Ensure that you are running the new OS by issuing a `set config` command and checking the version.
5. Ensure that the PortServer II operates correctly with your configuration.
6. If the PortServer II operates correctly, load the new OS into flash ROM by supplying a `boot` command that specifies the following on the `load` field:

- The IP address of the TFTP host
- The name of the file that holds the new OS

The following message should appear:

```
The image in flash now appears valid.
```

7. If this message does not appear, do **not** reboot PortServer II. The unit may become inoperative if you do; call technical support for instruction on what to do next.

8. If this message appears, configure the PortServer II to boot off the OS in flash ROM by specifying `set config tftp=no`.
9. If you want to confirm this operation, reboot from the OS in flash ROM by specifying `boot action=reset`.

*Example*

The following is an example of the commands you supply to complete the OS upgrade procedure. The example does **not** include steps that do not use PortServer II commands, such as obtaining a copy of the new OS or checking that the new OS runs properly.

```
set config boothost=199.247.89.12
 bootfile=/bootfile1 tftpboot=smart

boot action=reset

set config

boot load=199.247.89.12:/bootfile1

set config tftpboot=no

boot action=reset
```

# Configuring PortServer II from a Remote Host

## Introduction

### *Introduction*

This section discusses remote configuration, that is, configuring PortServer II from a remote host and then downloading the configuration file to PortServer II.

### *When To Use Remote Configuration*

Typically, you use remote configuration when you have several PortServer IIs with similar configurations and want to keep a master configuration on a remote host, from which you can easily create variations for downloading to individual PortServer IIs.

### *Rules for Editing a Configuration file*

Here are some rules for editing a configuration file on a remote host:

- Edit the file with any text editor.
- Each line of the file must start with a `set` command, such as `set user` or `set line`. In other words, do not let commands wrap to the next line if your editor supports this function.
- When downloading a configuration file, PortServer II does not notify you of command syntax errors. It simply ignores the command, which means your configuration will not work as expected.

## Copying the Configuration File to a Host

### *Introduction*

This section describes how to copy the PortServer II configuration file to a remote host for editing.

### *Related Information*

See the `cpconf` command in the *PortServer II Command Reference*.

### *Starting Point*

This procedure assumes that you

- Have an existing configuration on the PortServer II that you want to copy to a remote host for editing
- Are logged in to PortServer II as `root`, which is a requirement for using the `cpconf` command to copy the configuration file to a host

### *Procedure*

1. Create a file with appropriate write permissions on the remote host.
2. Ensure that TFTP is running on the remote host.
3. Supply a `cpconf` command with a `tohost` field that specifies the following:
  - The IP address of the target host
  - The name of the file that will hold the configuration.

### *Example*

```
cpconf tohost=199.250.121.12 cnfg-file
```

## Copying a Configuration File from a Host to PortServer II

**Introduction** This section describes how to copy the configuration file from a host to PortServer II after the file has been edited on the host.

**Related Information** See the `cpconf` command in the *PortServer II Command Reference*.

**Starting Point** This procedure assumes that you

- Have edited a configuration file on a host and now want to copy it to PortServer II for use
- Are logged in to PortServer II as `root`, which is a requirement for using the `cpconf` command to copy the configuration file to a host

Supply a `cpconf` command with a `fromhost` field that specifies the following:

- The IP address of the source host
- The name of the configuration file on the host

**Example** `cpconf fromhost=199.250.121.12 cnfg-file`

## Resetting the Configuration to Defaults

### *Introduction*

This section describes how to reset PortServer II to configuration defaults.

**Note:** If you restore PortServer II to configuration defaults, all configuration changes previously entered will be lost.

### *Related Information*

See the `boot` command in the *PortServer II Command Reference*.

### *Starting Point*

This procedure assumes that you have logged in as `root`.

### *Procedure*

Specify the following: `boot action=eewrite`.

*chapter* **16** **Troubleshooting Tools**

***In this chapter***

This chapter describes PortServer II tools that can aid in troubleshooting problems.

- Introduction to PortServer II Controls and LEDs . . . . .16-2
- Running the Power On Self Test . . . . .16-3
- Running Hardware Diagnostics . . . . .16-4
- Displaying Serial Port Status . . . . .16-8
- Displaying Ethernet Status . . . . .16-9
- Tools for Solving Network Problems . . . . .16-10

## Introduction to PortServer II Controls and LEDs

### *Introduction*

This section introduces you to the PortServer II front panel controls and LEDs, which you use to gather certain kinds of troubleshooting information.

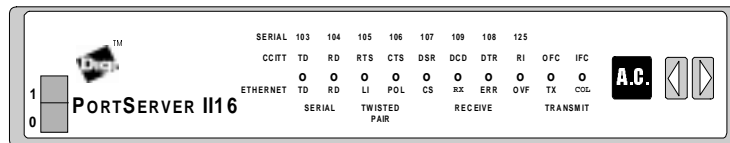

AR0034

### *Interpreting the Alphanumeric Display*

The alphanumeric display provides information on the following:

- That the POST test is running. **PO** indicates that the POST testing is running.
- PortServer II status. **AC** means POST tests passed and the unit is operating normally.
- Which of the POST tests failed. Error codes **E0** through **E9** indicate a failure in one of the POSTs.
- Which serial port the LEDs are reporting on. Numbers **1** through **64** identify the serial port on which the LEDs are reporting signal status and flow control information.
- Ethernet activity. **EA** indicates that the LEDs are reporting Ethernet activity.
- CPU use. **PU** indicates that the LEDs are reporting CPU use. If all LEDs are lighted, the CPU is 100% utilized.
- That PortServer II is booting from a remote server. **F** means that the unit is booting from a TFTP server, and **b** means it is booting from a bootp server.
- That PortServer II is clearing configuration information. **CL** indicates that configuration information is being cleared.
- That a TFTP error occurred. **F0** through **F7** indicate TFTP errors.

### *Interpreting LEDs*

The LEDs report information on serial port signal status and flow control, Ethernet activity, and CPU use, depending on what is displayed in the alphanumeric display.

### *Using the Pushbuttons to Navigate Through LED Information*

The pushbuttons allow you to select the information you want the LEDs to report. You can select information on the following:

- A particular serial port
- The Ethernet interface
- CPU use

## Running the Power On Self Test

### *Introduction*

This section describes how to run the POST test.

### *Procedure*

Turn the power off and then on.

### *POST Results*

If all POST tests pass, AC appears in the alphanumeric display. If one of the tests fails, one of the following codes appear in the alphanumeric display.

| Code | Test That Failed               |
|------|--------------------------------|
| E0   | CPU                            |
| E1   | Watchdog                       |
| E2   | ROM checksum, flash ROM        |
| E3   | RAM x 100 to top of 64K memory |
| E4   | Timer and realtime clock       |
| E5   | Ethernet and Ethernet address  |
| E6   | On-board UARTs                 |
| E7   | External UARTs                 |
| E8   | Off when warm-booted           |
| E9   | Bad code in flash ROM          |

### *If a POST Test Fails*

If a POST test fails, call Technical Support.

# Running Hardware Diagnostics

## Introduction to Hardware Diagnostics

**Introduction** This section describes how to run diagnostics on the PortServer II hardware.

**Methods** You can run diagnostics from either of the following:

- A terminal (or PC with terminal emulation software) connected to Port 1
- The PortServer II's front panel

## Running Hardware Diagnostics from a Terminal

**Starting Point** This procedure assumes that you have connected a terminal to port 1 and configured the terminal for VT100 emulation, 9600 baud, 8 data bits, 1 stop bit, and no parity.

**Note:** Ensure that your terminal will send the v character when the DTR and RTS lines on the serial port are low (inactive). If you encounter a problem, use a 3-wire connection to the terminal.

**Procedure**

1. Start Diagnostics:
  - a. Turn the power off and then on.
  - b. When PO appears in the alphanumeric display, press V to enter diagnostic mode.

A display similar to the following appears.

```
Digi International Inc. PortServer II
Ethernet address...12:34:56:78:9A:BC
ROM revision: 91-398 Rev D
ROM startup (cold boot)
Instruction cache size: 0x00001000
Data cache size: 0x00000800
RAM size: 0x00200000
CPU test.....passed
Watchdog test.....passed
ROM checksum test...passed
Flash RAM test.....passed
Simple
RAM test.....0xA00010000xA01F0010 passed
Complex
RAM test.....0xA00010000xA0002000 passed
Timer test.....passed
```

```
RT clock+RAM test...passed
Ethernet internal...passed
Ethernet external...passed
Test EBI 0 UART08..15 devices passed
EBI 1.....none
EBI 2.....none
EBI 3.....none
Press "?" for diagnostics menu
or carriage return to continue booting
```

**2.** Press ? to display the Diagnostics Menu.

The following appears.

```
DIAGNOSTICS MENU---
A = All tests (except 9)
1 = Front panel light test
2 = RAM test
3 = Timer and real-time clock test
4 = EBI internal loopback test
5 = EBI external loopback test
6 = Ethernet internal loopback test
7 = Ethernet external loopback test
8 = Flash RAM test
9 = Watchdog test
C = Configure boot
T = Set date & time
Ethernet address: 12:34:56:78:9A:BC
B = Reboot
```

**3.** To start a test, press the appropriate test number.

See *Hardware Diagnostic Test Descriptions* on page 16-7 for information on individual tests.

## Running Hardware Diagnostics from the Front Panel

### *Introduction*

This section describes how to run diagnostics from the front panel.

### *Procedure*

1. Start Diagnostics:
  - a. Turn the power off and then on.
  - b. When PO appears in the alphanumeric display, press either the left (<) or right (>) pushbutton on the front panel to enter diagnostic mode.
2. Select one of the tests listed below by doing the following:
  - a. Use the right pushbutton (>) to cycle through the tests until the desired test number is displayed in the alphanumeric display.
  - b. Press the left pushbutton (<) to start the test.

A = All tests (except 9)

1 = Front panel light test

2 = RAM test

3 = Timer and real-time clock test

4 = EBI internal loopback test

5 = EBI external loopback test

6 = Ethernet internal loopback test

7 = Ethernet external loopback test

8 = Flash RAM test

9 = Watchdog test

C = Configure boot

T = Set date & time

The test will continue until an error is detected or you stop it. See *Hardware Diagnostic Test Descriptions* on page 16-7 for information on individual tests.

3. To stop a test, press the left pushbutton (<).

If a test passes, a P plus the test number will be displayed in the alphanumeric display (example: P3). If it fails, F plus the test number will be displayed (example: F3).

## Hardware Diagnostic Test Descriptions

### *Introduction*

The following explains the operation of each diagnostic test.

### *Tests*

#### **Test 1 - Front Panel Light**

Cycles LEDs on and off. It also cycles both alphanumeric displays. Make a visual check to ensure that all cycle correctly.

#### **Test 2 - Memory**

Tests memory. This test takes about two minutes for each pass.

#### **Test 3 - Timer**

Ensures that the timer counts and interrupts. It tests the real-time clock, checking the set time for legal values and tests the battery-backed RAM in real-time clock.

#### **Test 4 - Built-in UART and External EBI Internal Loopback**

It tests that the UARTs interrupt and that data loops back.

#### **Test 5 - Built-In UART and External EBI External Loopback**

Same as Test 4, but uses an external loopback. From the front panel, press the right pushbutton (>) to select the port to test. The display will cycle from 01 to 16 (or higher, if you have expansion modules connected) plus A11. With the number of the port to test displayed, press the left pushbutton (<) to start the test.

#### **Test 6 - Ethernet Internal Loopback**

Tests the 10BaseT and 10Base2 circuits within PortServer II.

#### **Test 7 - Ethernet External Loopback**

Verifies correct operation of the Ethernet interfaces to the external network. You must have a dummy network (for example, a "T" connector with termination resistors) attached to each Ethernet connector for this test to pass.

#### **Test 8 - Flash ROM**

(Read Only) Verifies that the Flash ROM can be read.

#### **Test 9 - Watchdog Timer**

Checks out the watchdog timer used to check system reliability.

## Displaying Serial Port Status

### *Introduction*

This section describes how to display the status of individual EIA-232 serial port connections from the front panel.

### *Procedure*

1. Use either of the pushbuttons until the port number appears in the alphanumeric display.
2. Use the LEDs for status information on the serial port connection.

The labels above the LEDs describe the type of information individual LEDs report. This information includes the functioning of the 8 EIA-232 signals and OFC, which tells you if output flow control is on, and IFC, which tells you if input flow control is on.

## Displaying Ethernet Status

### *Introduction*

This section describes how to display the status of the Ethernet connection.

### *Procedure*

1. Press either of the front panel pushbuttons until EA appears in the alphanumeric display.
2. Use the LEDs for status information. The table that follows describes the function of each LED.

| LED | When This LED Blinks...                                                                                                                                                                                            |
|-----|--------------------------------------------------------------------------------------------------------------------------------------------------------------------------------------------------------------------|
| LI  | It indicates a good connection to the Ethernet hub. This is used for twisted pair (10Base-T) connections only.                                                                                                     |
| POL | It indicates that polarity is backwards, that is, that the transmit and receive connections are transposed. PortServer II will still operate correctly. This is used for twisted pair (10Base-T) connections only. |
| CS  | PortServer II senses the Ethernet carrier.                                                                                                                                                                         |
| RX  | PortServer II is receiving packets over the Ethernet interface.                                                                                                                                                    |
| ERR | PortServer II received a packet with an error, such as a bad CRC or frame.                                                                                                                                         |
| OVF | It indicates an overflow condition. That is, packets are arriving faster than PortServer II can process them.                                                                                                      |
| TX  | PortServer II is transmitting over the Ethernet interface.                                                                                                                                                         |
| COL | PortServer II detected a collision, though not necessarily involving packets sent by or intended for the PortServer II.                                                                                            |

## Tools for Solving Network Problems

### *Introduction*

This section briefly describes three commands that can help you solve certain network problems.

### *About the ping Command*

The `ping` command enables you to determine if another host is active and can be reached by PortServer II. See the *PortServer II Command Reference* for information on using `ping`.

### *About the traceroute Command*

The `traceroute` command enables you to map a path to a destination. Used to troubleshoot routing problems, the `traceroute` command provides a list of all the routers through which a packet travelled on its way to a destination. See the *PortServer II Command Reference* for information on using `traceroute`.

### *About the info Command*

The `info` command enables you to display information capture in network statistics tables. This includes information on the following:

- Frame relay
- ICMP
- IP
- Ethernet
- TCP
- UDP

See the *PortServer II Command Reference* for information on using the `info` command.

## *Appendix A*

# **Configuring CU and UUCP To Dial Out**

### ***In This Appendix***

This appendix discusses an alternative to RealPort for modem connections involving Unix systems for which a RealPort driver is not available.

- About RTTY .....A-2
- Description of Operation .....A-3
- Configuring Your System. ....A-4
- RTTY Program. ....A-5

## About RTTY

### *Introduction*

RTTY works by associating a pseudo TTY port with a particular port or port “group” on the PortServer II. The pseudo TTY operates similarly to a regular port, allowing you to use kermit, UUCP, CU, and similar programs.

### *Obtaining RTTY*

You can obtain a copy of RTTY from the Digi International FTP server. The source code is available to customers, and you can also download binaries for most popular operating systems.

### *Disclaimer and Limitations*

RTTY is provided on an “as-is” basis by Digi International, but it is not covered by our unlimited technical support policy. Digi provides the source, internal documentation in the source, and an unlimited distribution license when used with our products.

RTTY does not work with STREAMS-based pseudo TTYs.

We recommend that you read your UNIX man pages to find out what your system supports. If your system supports BSD-style pseudo TTYs, you can display the devices available by typing:

```
ls /dev/pty*
```

## Description of Operation

The pseudo TTY driver will not allow access to the “master” side of a pseudo TTY by more than one program at a time, so once RTTY accesses a pseudo TTY, it retains control and excludes other programs.

To drop a connection, RTTY must close the device and then reopen it. Although the device is closed for only a few milliseconds, it is still possible for another program to gain control of the device before RTTY can resecure it. If that happens, CU and UUCP may not operate correctly. We recommend that you select a high port number to minimize problems.

Several computer systems on a network can be configured with pseudo-TTYs associated with the same port (or port group) on a PortServer II. This is possible because RTTY only attempts a connection when data is written to the pseudo-TTY. If the PortServer II port is available, the connection is made and the program accessing the port can continue. If the port is already in use by another system, the connection fails (RTTY signals the application by momentarily closing and re-opening the pseudo-TTY port). This method of operation is compatible with UUCP and CU on most systems.

## Configuring Your System

1. If, for example, you found `/dev/tty[ p q r s ] [ 0 - f ]` on your system (64 ptys), and you want to configure four modem ports, you could use `/dev/tty[ c d e f ]` for your pseudo-modem ports.

If you want to use PortServer II ports 1-4, add the lines shown below to your "rc" startup script. The parameter "1" adds a one second delay after connection before sending data. (This ensures DTR high is established before the modem looks for "AT" commands). The "d" parameter runs the program as a daemon, and the "s" parameter suppresses the Copyright Notice during bootup.

```
rtty -lds /dev/ttysc dbps-nodename 2101
rtty -lds /dev/ttysd dbps-nodename 2102
rtty -lds /dev/ttyse dbps-nodename 2103
rtty -lds /dev/ttysf dbps-nodename 2104
```

**Note:** Use **21xx** raw connect port numbers, not **20xx** series telnet connect numbers.

2. Add the modems to your UUCP Devices file, as shown below. On some systems, you can omit the `hayes` keyword; on other systems, you must replace it with the name of the dialer script your modem uses.

**Note:** The actual baud rates you enter are ignored by the pseudo-TTY device driver, but they must match the values in your Systems file.

```
ACU ttysc tty-sc 38400 hayes
ACU ttysd tty-sd 38400 hayes
ACU ttyse tty-se 38400 hayes
ACU ttysf tty-sf 38400 hayes
```

3. The modems now appear directly connected to CU and UUCP. Test your configuration by typing a command similar to the following example:

```
cu -l /dev/ttysc -b 38400 555-1212
```



```

*-xOutput debugging information. Specifying "x"
* twice produces even more output.
*
*
*To associate "ttypf" with the dedicated printer device
*connected to (PortServer II) node ncx, port 4.
*
*rTTY -dh ttypf ncx 2104
*
*To associate "ttysf" with a dial-in/dial-out (type mio)
*modem attached to (PortServer II) node dbps port 13.
*
*rTTY -ld ttysf dbps 2113
*/

static char *copyright[] =
{
"@(#)Copyright 1992, Digi International, All Rights
Reserved.",
"@(#)An unlimited use and distribution license is
granted for use with,",
"@(#)and only with, Digi terminal servers and other net-
work products.",
0
} ;

```

# Index

## A

- autoconnection
  - configuration example 2-4
  - configuring by port 13-3
  - configuring by user 13-4
  - introduction to 13-2

## B

- boot command 2

## C

- command line
  - configuring access to 12-6
  - introduction to the interface 1-3
- computer connections
  - configuring 6-4
- configuration
  - configuring access to 12-2
  - copying to a host 4
  - copying to PortServer II 5
  - remote 4
  - restoring all defaults 6
- configuration commands 1-2
- configuration example
  - autoconnection 2-4
  - dial-in PPP and Proxy ARP 2-16
  - dial-in PPP using RADIUS 2-12
  - dial-out PPP to network 2-10
  - frame relay 2-14
  - RealPort 2-6
  - terminal server without RealPort 2-2
- configuration terminal, setup 1-4
- configuration, downloading from a host 1-6
- cpconf command 4

## D

- default gateway, configuring 3-3
- Diagnostics
  - terminal 16-4
- diagnostics 16-4
- DNS
  - configuring a host file 14-3
  - configuring a name server 14-3
  - introduction to 14-2
- Domain Name System
  - configuring a name server 14-3
  - introduction to 14-2
- domain name system
  - configuring a host file 14-3

## E

- Ethernet interface, configuring 3-2
- Ethernet status 16-9

## F

- filter
  - configuring 8-8
  - criteria 8-8
  - rules 8-10
- frame relay
  - configuration example 2-14
  - configuring 9-3
  - planning 9-2
- front panel controls 16-2

## H

- hardware diagnostics 16-4
- help, accessing 1-3

## I

- inbound ports
  - configuring access to 12-3

info command 16-10  
IP address, configuring the Ethernet  
interface 3-2

## **L**

LEDs 16-2

## **M**

modems  
configuration tips 7-2  
configuring 7-3, 7-5

## **N**

network statistics tables 16-10  
newpass command 12-8

## **O**

online help, accessing 1-3  
operating system  
updating 2

## **OS**

updating 2  
outbound ports  
configuring access to 12-5

## **P**

passwords  
issuing 12-8  
ping 16-10  
POST, running 16-3  
power on self test, running 16-3  
PPP  
configuration example 2-10, 2-12, 2-16  
configuring 8-2

## **printers**

configuration considerations 5-2  
configuring 5-4  
configuring direct access printing 5-2

## **Proxy ARP**

configuration example 2-16  
configuring 10-9

## **R**

### **RADIUS**

configuration example 2-12

configuring 12-7

### **RealPort A-1**

configuration example 2-6  
configuring 4-3  
features 4-2

remote configuration 4

### **routing**

about RIP 10-3  
configuring dynamic routes 10-7  
configuring static routes 10-5  
introduction to 10-2

### **RTTY A-2**

source code A-5

## **S**

### **security**

configuring access to inbound ports 12-3  
configuring access to outbound ports 12-5  
configuring access to the command  
line 12-6  
configuring command line access 12-2  
using RADIUS 12-7

serial port status 16-8

set config command 2

### **SLIP**

configuring 8-6

### **SNMP**

configuring 11-4  
introduction to 11-2

### **Statistics**

Viewing 10-5, 12-5, 1

### **STREAMS A-2**

## **T**

### **terminal server**

configuration example 2-2

### **terminal, configuring the configuration**

terminal 1-4

### **terminals**

configuring 6-2

traceroute 16-10