



**Connectware™**

**PortServer TS 8/16**

**Configuration and Administration  
Guide**

The Digi logo is a trademark of Digi International.

All other brand and product names are trademarks of their respective holders.

© Digi International Inc., 1998, 2000, 2001, 2002. All Rights Reserved

<http://www.digi.com>

Information in this document is subject to change without notice and does not represent a commitment on the part of Digi International.

Digi provides this document “as is”, without warranty of any kind, either expressed or implied, including, but not limited to, the implied warranties of fitness or merchantability for a particular purpose. Digi may make improvements and/or changes in this manual or in the product(s) and/or the program(s) described in this manual at any time.

This product could include technical inaccuracies or typographical errors. Changes are periodically made to the information herein; these changes may be incorporated in new editions of the publication.

## **Chapter 1 Introduction**

In This Chapter .....	6
Setup Overview.....	6
About Entering Commands on the Command Line.....	7
Supported Devices .....	8
About This Guide.....	8
Other Documents in the Library .....	8
About Configuration Methods .....	9
Configuration Prerequisites .....	9

## **Chapter 2 Configuring the IP Address**

In This Chapter .....	11
Options for Configuring the IP Address and Mask .....	11
Configuring the Ethernet Interface with Digi Port Authority-Remote .....	12
Configuring the IP Address Using ARP-Ping .....	13
Configuring the Ethernet Interface from the Command Line.....	13
Configuring an IP Address using DHCP and RARP .....	14

## **Chapter 3 Configuring Ports for RealPort**

In This Chapter .....	15
About RealPort .....	15
Configuring Ports: Web Interface.....	16

## **Chapter 4 Configuring Ports for Printers**

In This Chapter .....	17
Configuration Considerations .....	17
Configuring Ports for Printers: Web Interface.....	19
Configuring a Port for Direct-Access Printing .....	19

## **Chapter 5 Configuring Ports for Terminals and Computers**

In This Chapter .....	21
Configuring Ports for Terminals: Web Interface .....	21
Configuring Ports for Terminals: Command Line.....	22
About Computer Connections .....	23

## **Chapter 6 Configuring Ports for Modems**

In This Chapter .....	24
Tips on Configuring A Modem .....	24
Configuring Ports for Modems: Web Interface .....	25
Configuring Ports for Incoming Modem Connections: Command Line .....	25
Configuring Ports for Outgoing/Bi-Directional Connections: Command Line.....	26

## **Chapter 7 Configuring PPP**

In This Chapter .....	28
Configuring PPP Connections: Web Interface .....	29
Configuring Inbound PPP Connections: Command Line.....	29
Configuring Outbound PPP Connections: Command Line .....	31

<b>Chapter 8 Configuring IP Routing</b>	
In This Chapter .....	34
Configuring Static Routes .....	34
Configuring Dynamic Routes Using RIP .....	35
Configuring Proxy ARP.....	36
<b>Chapter 9 Configuring Autoconnection</b>	
In This Chapter .....	38
About Autoconnection .....	38
Configuring a Port for Autoconnection: Web Interface .....	39
Configuring Autoconnection By Port: Command Line .....	39
Configuring a User for Autoconnection: Web Interface.....	39
Configuring a User for Autoconnection: Command Line .....	40
Configuring TCP Socket Communication .....	41
<b>Chapter 10 Configuring Console Management</b>	
In This Chapter .....	42
About Console Management .....	42
Configuring Console Management: Web Interface .....	42
Configuring Console Management: Command Line .....	43
<b>Chapter 11 Configuring Security Features</b>	
In This Chapter .....	45
Controlling Access to the Configuration .....	45
Controlling Access to Inbound Ports .....	46
Controlling Access to Outbound Ports .....	46
Controlling Access to the Command Line.....	47
Using RADIUS to Authenticate Users .....	47
Issuing User Passwords .....	50
Configuring SSH Version 2 for Secure Communication.....	50
Controlling Access to Services .....	52
<b>Chapter 12 Configuring DNS</b>	
In This Chapter .....	53
About the Domain Name System .....	53
Configuration Procedures .....	54
<b>Chapter 13 Configuring SNMP</b>	
In This Chapter .....	55
About SNMP and the PortServer TS 8/16 Agent .....	55
Configuration Procedure: Web Interface .....	56
<b>Chapter 14 Managing the OS and Configuration</b>	
In This Chapter .....	57
Upgrading the Firmware.....	57
Copying the Configuration to and from a Remote Host.....	58
Resetting the Configuration to Defaults .....	60
<b>Chapter 15 Configuring Users</b>	
In This Chapter .....	61
About Configuring Users.....	61

Common User Features .....	62
Configuring a User: Web Interface.....	62
Configuring a User: Command Line Examples.....	63
<b>Chapter 16 Configuration Examples</b>	
In This Chapter .....	64
Terminal Server Configuration Without RealPort.....	65
Terminal Server Configuration Using Autoconnection.....	66
Terminal Server Configuration Using RealPort .....	67
Dial-In PPP Connection Using RADIUS .....	67
<b>Chapter 17 PortServer TS 8/16 Troubleshooting</b>	
Symptom: PortServer TS 8/16 Does Not Boot.....	70
Symptom: Cannot Telnet to the PortServer TS 8/16 .....	70
Symptom: Trouble Accessing a Port .....	71
Running PortServer TS 8/16 Hardware Diagnostics .....	71
Running PortServer TS 8/16 POST .....	72
Verifying TFTP on a UNIX System.....	73
Troubleshooting TFTP Problems.....	73
Resetting PortServer TS 8/16 Configuration to Defaults .....	74
Verifying the PortServer TS 8/16 IP Address.....	75
Checking for Duplicate IP Addresses .....	75
Pinging an IP Address.....	75
Verifying the Network Cabling .....	76
Verifying the RealPort Process.....	76
Checking and Changing Port Configuration.....	78
Digi Contact Information.....	79

## Chapter 1

## Introduction

### In This Chapter

• Setup Overview .....	6
• About Entering Commands on the Command Line .....	7
• Supported Devices .....	8
• About This Guide .....	8
• Other Documents in the Library .....	8
• About Configuration Methods .....	9
• Configuration Prerequisites .....	9

### Setup Overview

This section provides an overview of the setup process.

#### Step A: Plan

Before beginning setup, consider the following:

- How to assign an IP address to the Digi device's Ethernet interface, which can be accomplished in a number of ways. See "Configuring the IP Address" on page 11.
- How to configure serial ports. A key consideration is whether to use RealPort. Other considerations include the type of peripheral that will connect to the port and the peripheral's cabling requirements. See "Configuring Ports for RealPort" on page 15 and the online RealPort driver documentation and Cable Guide, both of which are on the Access Resource CD.
- The various ways that your Digi device can be configured. See "About Configuration Methods" on page 9 and "Configuration Prerequisites" on page 9 for more information.

## **Step B: Set Up the Hardware**

1. Connect the device to power and to the network.
2. Connect peripherals to serial ports. See the Cable Guide on the Access Resource CD.

## **Step C: Install and Setup Digi Port Authority-Remote**

Digi Port Authority-Remote is a utility that provides one of the ways to configure an IP address and also provides port monitoring. See the *Digi Port Authority-Remote Device Monitor Setup Guide*, which is on the Access Resource CD.

## **Step D: Configure an IP Address**

There are a number of ways to configure an IP address. See "Configuring the IP Address" on page 11 for more information.

## **Step E: Configure Ports**

See the following for more information:

- "Configuring Ports for RealPort" on page 15
- "Configuring Ports for Printers" on page 17
- "Configuring Ports for Terminals and Computers" on page 21
- "Configuring Ports for Modems" on page 24

## **Step F: Configure Other Features as Required**

See the following for information on setting up other features:

- "Configuring PPP" on page 28
- "Configuring IP Routing" on page 34
- "Configuring Autoconnection" on page 38
- "Configuring Console Management" on page 42
- "Configuring Security Features" on page 45
- "Configuring DNS" on page 53

## **Step G: Troubleshoot Setup Problems**

Troubleshoot problems as required. See "PortServer TS 8/16 Troubleshooting" on page 69.

## **About Entering Commands on the Command Line**

On the PortServer TS 8/16 command line, do not force a line break (by pressing Enter or Return). This will commit the command before you finish adding all command fields. If your terminal does not support wrapping to the next line and long commands scroll out of sight, the easiest way to enter long commands is by breaking the command into multiple commands as shown below. If you use this method, however, you must let the PortServer TS 8/16 know that you are configuring the same entity, such as the same port, menu, or line. This is done by repeating the range or name field in each command.

```
set menu t1="Console Management Menu" range=6
set menu range=6 name="Console Management Menu" m3="Connect to System 1" set
  menu range=6 c3="connect 1" m4="Connect to System 2"
set menu range=6 c4="connect 2"
```

## Supported Devices

This manual provides information on the following Digi devices:

- PortServer TS 8
- PortServer TS 16

## About This Guide

### Purpose

This guide provides the following:

- Configuration and administration procedures
- Configuration examples

### Audience

This manual is intended for the person responsible for configuring and administering PortServer TS 8/16. It assumes that this person has experience configuring network devices and is familiar with networking concepts.

### Scope

This manual provides step-by-step instructions for configuring and administering PortServer TS 8/16's main features. It does not address how to configure every option, provide complete information on commands, or discuss hardware installation. These topics are covered in other documents in the PortServer TS 8/16 library.

### About Command Line Examples

In this manual, many command examples are broken up and placed on two lines of the manual. This is done to control where the line breaks, making it as easy to read as possible. When this is done, the second line of the command will be indented slightly, as shown below.

```
set menu range=6 t1="Console Management Menu" name="Console Management
  Menu" m3="Connect to System 1" c3="connect 1" m4="Connect to System 2"
  c4="connect 2"
```

## Other Documents in the Library

Here is a list of the other documents in the library:

### *Access Resource CD Card*

This card provides information on the contents of the Access Resource CD. It includes the CD mounting instructions required to access the CD on many Unix systems.

### *PortServer TS 8/16 Setup Card*

This card, which comes in the PortServer TS 8/16 package, provides a brief overview on the setup process.

### *Digi One/PortServer TS Command Reference*

This online manual, available on the Access Resource CD, provides complete information on commands.

### *RealPort Setup Guides*

These online manuals provide information on setting up servers for RealPort software.

### ***Digi Port Authority - Remote Device Monitor Setup Guide***

This online manual provides information on installing and using Digi Port Authority - Remote software.

### ***Online Help for the Web UI***

This context-sensitive online help provides information on configuration fields used with web browser configuration interface.

## **About Configuration Methods**

Use this section to learn about configuration methods.

### **Configuring the PortServer TS 8/16 from an Attached Terminal**

With this method, you cable a terminal or PC running terminal emulation software to a PortServer TS 8/16 port and then use the command line to enter commands. This method allows you to configure all features. It requires, however, that you and the PortServer TS 8/16 be in the same location. Some users find it advantageous to configure the PortServer TS 8/16 IP address this way and then use one of the other methods for the rest of the configuration.

### **Configuring the PortServer TS 8/16 from a Telnet Session**

With this method, you Telnet to the PortServer TS 8/16 and use the command line to complete configuration tasks. The only disadvantage to this method is that you have to configure the PortServer TS 8/16 with an IP address before you can Telnet to it.

### **Configuring the PortServer TS 8/16 from the Web Interface**

The great advantage to this method is ease of use. This method does, however, require that you configure the IP address before you can access the configuration from the web interface, and some features cannot be configured this way.

### **Downloading a Configuration File**

With this method, you configure a Digi device and then do the following:

1. Download an existing configuration file to a host system.
2. Edit the file with specific configuration using a text editor.
3. Upload the file to the PortServer TS 8/16.

This an excellent method for maintaining highly similar configuration files for multiple Digi devices. The disadvantage is that the PortServer TS 8/16 requires some configuration steps, such as the IP address, to be completed before it can be used.

## **Configuration Prerequisites**

### **Accessing the Command Line from a Locally-Connected Terminal**

Use this procedure to access the command line and the configuration from a terminal connected to one of the PortServer TS 8/16's serial ports.

1. Connect a terminal or PC to a serial port on the PortServer TS 8/16. For a Windows Hyperterminal connection, use the cable that came in the package.

2. Configure the parameters of the terminal or terminal emulation software to work with the Digi serial port. The default port settings are:
  - VT 100 emulation
  - 9600 baud
  - 8-bit character
  - 1 stop bit
  - No parity
3. Log in as the root user. The default password is dbps.

### **Logging On As Root from the Command Line**

1. At the login prompt, enter the following: `root`
2. At the password prompt, supply the root password. The default is dbps.

### **Accessing the Command Line from a Telnet Session**

Use this procedure to access the command line and the configuration from a Telnet session. This procedure assumes that you have configured the Digi device with an IP address already. See "Configuring the IP Address" on page 11.

1. To Telnet to the PortServer TS 8/16, enter the following command from a command prompt on another networked device, such as a server:

```
telnet ip-address
```

where *ip-address* is the PortServer TS 8/16's IP address

Example: `telnet 192.3.23.5`

2. Log in as the root user. The default password is dbps.

### **Accessing the Configuration from the Web Interface**

Use this procedure to access the configuration from the web interface. This procedure assumes that you have configured the Digi device with an IP address already. See "Configuring the IP Address" on page 11.

1. Access the PortServer TS 8/16 from a web browser by specifying the PortServer TS 8/16's IP address in the URL window.
2. Log on as root. The default password is dbps.

*Chapter 2*

## **Configuring the IP Address**

### **In This Chapter**

This chapter discusses how to configure PortServer TS 8/16's IP address and other features associated with its Ethernet interface. It discusses the following topics:

- Options for Configuring the IP Address and Mask..... 11
- Configuring the Ethernet Interface with Digi Port Authority-Remote ..... 12
- Configuring the IP Address Using ARP-Ping..... 13
- Configuring the Ethernet Interface from the Command Line..... 13
- Configuring an IP Address using DHCP and RARP ..... 14

### **Options for Configuring the IP Address and Mask**

#### **Options**

The PortServer TS 8/16 IP address can be configured using the following methods:

- With Digi Port Authority-Remote, a Digi utility
- By updating the ARP table on a server and then pinging the Digi device (called ARP-Ping)
- From the command line using the set config command
- Using a RARP server
- Using a DHCP server

The IP address and mask can also be changed using the web interface. This method, however, does not work for the initial IP address configuration.

## Device Support: Digi Port Authority-Remote and ARP-Ping for IP Address Configuration

Not all Digi devices can use Digi Port Authority-Remote and ARP-Ping for IP address configuration. To determine if you can use these features, find the hardware label on your Digi device and then use the table below to determine whether this feature is available:

Device	Part Number	Revision Required
PortServer TS 8	50001208-01	B or higher
PortServer TS 16 (desktop)	50001207-01	E or higher
PortServer TS 16 (rack-mounted)	50001185-01	C or higher

## Configuring the Ethernet Interface with Digi Port Authority-Remote

Use this section to configure an initial IP address, subnet mask, and default gateway using Digi Port Authority-Remote. This procedure cannot be used to change the IP address, but only to assign the initial IP address. It also cannot be used if a DHCP server is active.

### Starting Point

This procedure assumes the following:

- That your Digi device supports this feature. See "Device Support: Digi Port Authority-Remote and ARP-Ping for IP Address Configuration" on page 12.
- That your Digi device is connected to the Ethernet network
- That the Digi device has DHCP client turned on. This is the default setting, so it will be on unless it was turned off.
- That you do **not** have a DHCP server to serve IP address. If you do, use the DHCP procedure. See "Configuring an IP Address using DHCP and RARP" on page 14.
- That you have installed Digi Port Authority-Remote version 2.01.11 or later. For information on installing Digi Port Authority-Remote, see the *Digi Port Authority Remote Device Monitor Setup Guide*, which is on the Access Resource CD.

### Procedure

1. Run Digi Port Authority-Remote.
2. If Digi Port Authority-Remote is not set for ADDP, choose ADDP as the Discovery Protocol.
3. Choose Discover.

A list of Digi devices appears. Systems with IP addresses of 0.0.0.0 need IP addresses.

4. Select a device from the list and then choose Configure.
5. Supply an IP address, subnet mask and default gateway and then choose OK.

Digi Port Authority-Remote configures the IP address, subnet mask and default gateway.

## Configuring the IP Address Using ARP-Ping

Use this section to configure an IP address by manually updating a server's ARP table and then pinging the Digi device.

### Starting Point

This procedure assumes the following:

- That your Digi device supports this feature. See "Device Support: Digi Port Authority-Remote and ARP-Ping for IP Address Configuration" on page 12.
- That your Digi device is connected to the Ethernet network

### Procedure

1. Record the MAC address of the Digi device. It's on the back of the unit.
2. Access a server on the same subnet as the Digi device.
3. Manually update the server's ARP table using the Digi device's MAC address and the IP address you want assigned to the Digi device. The following is an example of how this is done on a Windows NT 4.0 system:  

```
arp -s 143.191.2.1 00-00-9d-22-23-60
```
4. Ping the Digi device using the IP address just assigned. The following is an example:  

```
ping 143.191.2.1
```

The ping will probably time out before there is a response from the Digi device.
5. Wait a few seconds and then ping the Digi device again.  

The Digi device replies to the ping, indicating that the IP address has been configured.

## Configuring the Ethernet Interface from the Command Line

This section discusses how use the command line to configure an IP address, mask, and default gateway for PortServer TS 8/16's Ethernet interface.

### Manual Configuration Procedure

1. To ensure that the IP address you configure is permanent, turn DHCP off by entering the following command:  

```
set config dhcp=off
```
2. To configure an IP address for the Ethernet interface, enter the following command:  

```
set config ip=ip-address
```

where *ip-address* is the IP address for the Ethernet interface

#### *Example*

```
set config ip=191.143.2.154
```

3. To configure a subnetmask, enter the following command:  

```
set config submask=mask
```

where *mask* is the subnet mask for this subnetwork

#### *Example*

```
set config submask=255.255.255.0
```

4. To configure a default gateway, enter the following command:

```
set config gateway=ip-address  
where ip-address is the IP address of the default gateway
```

**Example**

```
set config gateway=191.143.2.46
```

5. Reboot the Digi device at the prompt using the following command:

```
boot action=reset
```

**Manual Configuration Example**

In this example set config commands configure the Ethernet interface and the boot command reboot the Digi device, which is required for the address change to take affect.

```
set config ip=192.150.150.10 submask=255.255.255.0 dhcp=off  
set config gateway=192.150.150.11  
boot action=reset
```

**Configuring an IP Address using DHCP and RARP**

**About DHCP and RARP**

When the PortServer TS 8/16 boots, it transmits a DHCP request and a RARP request. This continues until an address is assigned.

**Procedure**

To use RARP or DHCP follow these steps:

1. Set up an entry for an address on a DHCP or RARP server. If you intend to use RealPort, do the following:
  - Reserve a permanent IP address.
  - Record the IP address. You will need it when you configure the RealPort driver.
2. Power on the PortServer TS 8/16.  
The DHCP or RARP server assigns the PortServer TS 8/16 an IP address.

## In This Chapter

This chapter describes how to configure PortServer TS 8/16 for RealPort connections. It discusses the following topics:

- About RealPort..... 15
- Configuring Ports: Web Interface ..... 16

## About RealPort

This section provides a brief introduction to RealPort.

### What is RealPort?

RealPort is a feature that allows network-based host systems to use the ports of the PortServer TS 8/16 as though they were the host system's own ports, appearing and behaving as local ports to the network-based host.

### RealPort Advantages

RealPort provides the following advantages:

- It expands the number of ports available to the host system.
- It enables PortServer TS 8/16 ports to be treated as if they were directly connected to the host, which means they use all standard operating system interfaces that control baud rate, parity, stop bits, and flow control.
- It enables host administrators to do most of the required configuration on the host, the system with which the administrator is most familiar.
- It dramatically reduces host CPU overhead because multiple terminal or printer sessions are multiplexed over the same TCP/IP connection.

### Configuring the RealPort Software

You must install and configure RealPort software on each host that will use RealPort ports. See the RealPort documentation for more information.

## Configuration Options

You can configure PortServer TS 8/16 for RealPort from the command line or using the web interface. For information on using the web interface, see "Configuring Ports: Web Interface" on page 16.

## Configuring Ports: Web Interface

Use this procedure to configure a port from the web interface.

1. Access the web interface by entering the PortServer TS 8/16 IP address in a browser's URL window.
2. Log in to the PortServer TS 8/16 as root.

The default password is dbps.

3. From the main menu, select Configure > RealPort.

A screen similar to the following appears.

**Digi** **RealPort**  
Connectware™

Information RealPort configuration introduction.

Configure

Ports The following pages will help you configure a port or ports on this PortServer TS 16 for use with the Digi RealPort driver. This will overwrite any settings you might have changed on any ports you decide to configure. You will also need to configure the RealPort driver on the server you wish to use with this unit.

RealPort

Users

Menus

DHCP

Network

Port Buffering

PPP

RADIUS

SNMP

Console Mgmt

AutoConnect

Time

Report

Admin

Help

Logout

4. To complete configuration, choose Next and then follow the prompts.
5. To return to the main Ports menu, choose Ports from the Menu again.
6. To complete RealPort setup, install and configure the RealPort driver. See the appropriate RealPort setup guide on the Access Resource CD.

### In This Chapter

This chapter describes how to configure PortServer TS 8/16 ports for printer connections. It discusses the following topics:

- Configuration Considerations .....17
- Configuring Ports for Printers: Web Interface .....19
- Configuring a Port for Direct-Access Printing .....19

### Configuration Considerations

You should be aware of the following considerations if you intend to configure PortServer TS 8/16 to handle printers.

#### Using RealPort

RealPort, a feature that allows network-based host systems to use the ports of the PortServer TS 8/16 as though they were the host system's own ports, is an easy and efficient way for printers to use PortServer TS 8/16 ports. For information on this option, see "Configuring Ports for RealPort" on page 15.

#### Determining Your Printer's Flow Control Requirements

If you set the PortServer TS 8/16 flow control parameters incorrectly, the printer may not print all data sent to it. Consequently, before you configure a PortServer TS 8/16 port for a printer, check the printer's documentation to determine if it uses hardware flow control, software flow control, or no flow control at all.

#### Flow Control Tips

Here are some tips to ensure that your printer performs as expected:

- If flow control is necessary, ensure that the printer and PortServer TS 8/16 use the same flow control scheme.
- Most printers that use hardware flow control issue the DTR (data terminal ready) signal when they are ready for data. If so, the DTR pin on the cable from the printer must be wired to an input on the PortServer TS 8/16 port (usually CTS or DCD) that can be used for flow control.

## Printing with AIX Systems

Digi does not recommend using lpd to print multiple jobs to a PortServer TS 8/16-attached printer from an AIX print spooler because this may cause the print job to time out.

### Using the lpd Protocol

Here are some tips for configuring the print spooler on your UNIX system when you intend to print using the lpd protocol to a printer attached to PortServer TS 8/16:

1. The number of copies option with lpr is not supported.
2. Banner pages are not supported.
3. Give the PortServer TS 8/16's DNS name or IP address as the remote system's name.
4. Specify a queue name that conforms to the following conventions:
  - Begin the queue name with one of the following character strings: (a) Use `ascii` if you want PortServer TS 8/16 to substitute carriage return and `and` line feed characters for each line feed the system sends. (b) Use `raw` if no substitution should be performed.
  - After the queue name, insert an underscore character and the number of the PortServer TS 8/16 port to which the printer is attached.
  - If you want to use either of the following options, specify an additional underscore and then the letter that identifies the option: (a) Use `f` to append a form feed character to the end of each file in a print job (b) Use `d` to add a Ctrl-d to the end of each file in a print job. (This is often required by PostScript printers.)

#### Examples

String	Result
<code>ascii_1</code>	Prints to port 1 and translates CR to CR/LF.
<code>ascii_8_f</code>	Prints to port 8, translates CR to CR/LF and prints a form feed at the end of the job.
<code>raw_1_d</code>	Prints to port 1 with no translation and appends a Ctrl-d to the end of the print job.

### Tips for telnet and rsh Printing

Here are some tips for handling telnet and rsh printing:

- If line feed and carriage return problems occur, try supplying a set line command that specifies `onlcr=on`. This converts carriage returns to carriage return/line feeds.
- If you want tab characters (ASCII character 9) converted to 8 spaces, use a set line command that specifies `otab=on`.

## Configuring Ports for Printers: Web Interface

Use this procedure to configure a port from the web interface.

1. Access the web interface by entering the PortServer TS 8/16 IP address in a browser's URL window.
2. Log in to the PortServer TS 8/16 as root.

The default password is dbps.

3. From the main menu, choose Configure > Ports.
4. To configure a port, do the following:
  - a. Choose the port from the port column.
  - b. Ensure that the Device Type is Printer.
  - c. Make other changes to the configuration as required. Use the online help for information.
  - d. If you want to apply this configuration to multiple ports, choose Clone, select the ports for this configuration, and then choose Continue.
  - e. Choose Submit.
5. To return to the main Ports menu, choose Ports from the menu again.

## Configuring a Port for Direct-Access Printing

Direct access printing allows Telnet users on the LAN to access a port and to issue print commands directly to the printer. This section describes the two ways users can access a printer directly and explains how to configure the port to support each method.

### Method 1: Specifying Port Numbers in the Telnet Command

This method allows users to issue telnet commands that identify the correct port by using TCP port numbers. Users identify the type of connection and port number by specifying one of the following:

For this connection type...	Identify the port by specifying...
Telnet	2000 plus the number of the port. <b>Example:</b> 2002 for port 2.
Raw	2100 plus the number of the port. <b>Example:</b> 2102 for port 2.

### User Command Example 1

In this example, a user specifies a standard telnet connection on port 2 of a PortServer TS 8/16 using IP address 199.250.38.15.

```
cat myfile | telnet 199.250.38.15 2002
```

### User Command Example 2

In this example, a user specifies a raw telnet connection on port 2 of a PortServer TS 8/16 using IP address 199.250.38.15.

```
cat myfile | telnet 199.250.38.15 2102
```

**Note:** To specify a hunt group in the command instead of an individual port, use the group number specified on the group field of the set ports command that configured the port.

## **Method 1 Configuration**

There is no special configuration required to set up a port for this type of direct access. Simply configure the port for a printer. See "Configuring a Port for Direct-Access Printing" on page 19 for more information.

## **Method 2: Using Alternate IP Addresses**

This method provides similar functions to method 1, except alternate IP addresses allow users to identify a specific port by simply specifying an IP address.

## **Method 2 Configuration**

To configure an alternate IP address, do the following:

- Configure the port for a printer. See *Configuring a Port for Direct-Access Printing* on page 19 for more information.
- Supply a set altip command that specifies the following:

```
set altip group=port-number ip=ip-address
```

where

— *port-number* is the number of a PortServer TS 8/16 port

— *ip-address* is the IP address of the PortServer TS 8/16

## **Command Line Example**

```
set ports range=2 dev=prn
set line range=2 baud=9600 csize=8 stopb=1 parity=n
set flow range=2 cts=on rts=on ixon=off ixoff=off
set altip group=2 ip=199.250.38.17
```

## In This Chapter

This chapter describes how to configure PortServer TS 8/16 ports for terminal and computer connections. It discusses the following topics:

- Configuring Ports for Terminals: Web Interface.....21
- Configuring Ports for Terminals: Command Line .....22
- About Computer Connections.....23

## Configuring Ports for Terminals: Web Interface

Use this procedure to configure a port from the web interface.

1. Access the web interface by entering the PortServer TS 8/16 IP address in a browser's URL window.
2. Log in to the PortServer TS 8/16 as root.

The default password is dbps.

3. From the main menu, choose Configure > Ports.
4. To configure a port, do the following:
  - a. Choose the port from the port column.
  - b. Ensure that the Device type is set to Terminal.
  - c. Make changes to the configuration as required. Use the online help for information.
  - d. If you want to apply this configuration to multiple ports, choose Clone, select the ports for this configuration, and then choose Continue.
  - e. Choose Submit.
5. To return to the main Ports menu, choose Ports from the Menu again.

## Configuring Ports for Terminals: Command Line

This section describes how to configure PortServer TS 8/16 ports for terminal connections.

### Port Defaults

Here is the default configuration for PortServer TS 8/16 ports:

- VT-100 emulation
- 9600 baud
- 8-bit characters
- 1 stop bit
- No parity
- Software flow control

### Related Information

- For information on the set line, set ports, and set flow commands, see the *Digi One/PortServer TS Command Reference*.
- For information on configuring terminal ports for autoconnections, see, "Configuring Autoconnection" on page 38.

### Procedure

This procedure assumes the following:

- That you are logged in as root
- That you know the attributes, such as baud rate and parity, of the terminal that will be connected to this port

1. Supply a set ports command that specifies the following:

```
set ports range=range dev=term sess=num-of-sess
```

where *range* is a port or range of ports and *num-of-sess* is the number of simultaneous sessions the port user can maintain

2. Supply a set line command that specifies the following:

```
set line range=range baud=bps csize=characters parity=parity stopb=num-  
bits
```

where

- *range* is a port or range of ports
- *bps* is the line speed
- *characters* is the character size
- *parity* is the parity scheme to use on this line
- *num-bits* is the number of stop bits to use

3. If your terminal uses hardware flow control, supply a set flow command that specifies the following (software flow control is the default, so a set flow command is not required in that case):

```
set flow range=range ixoff=off ixon=off cts=on rts=on
```

where *range* is a port or range of ports

**Note:** You may need to use additional set flow command fields, depending on the flow control scheme required by your terminal. See the set flow command in the *Digi One/PortServer TS Command Reference* for more information.

## **Example**

In this example, port 1 and 2 are configured for connection to terminals using hardware flow control. The connection uses default for character size (8 bits), parity (no parity), and stop bits (1).

```
set ports range=1-2 sess=3 dev=term termttype=wy60
set line range=1-2 baud=19200
set flow range=1-2 ixon=off ixoff=off rts=on cts=on
```

## **About Computer Connections**

Configuring computer connections is very similar to configuring terminal connections, which is discussed on page 22. Consequently, this section simply discusses the differences between these connection types.

### **Starting Point**

This section assumes that

- You are logged in as root
- You know the attributes, such as baud rate and parity, of the PC that will be connected to this port

### **Configuring Typical PC Connections**

To configure a port for a directly-connected PC, where the PC always initiates the connection, configure the connection as you would a terminal connection, except on the set ports command do the following:

- Specify dev=min if you have a 10-pin null modem cable to support this type of connection.
- Specify dev=term if you do not have a 10-pin null modem cable

Consider defining the serial connection as a PPP link. See "Configuring PPP" on page 28 for more information.

### **Command Line Example**

In this example, ports 1-2 are set up for a BBS host.

```
set ports range=1-2 dev=prn group=70
set line range=1-2 baud=19200
set flow range=1-2 ixon=off ixoff=off rts=on cts=on
set altip group=70 ip=199.179.23.10
```

## In This Chapter

This chapter describes how to configure PortServer TS 8/16 ports for modem connections. It discusses the following topics:

- Tips on Configuring A Modem.....24
- Configuring Ports for Modems: Web Interface.....25
- Configuring Ports for Incoming Modem Connections: Command Line .....25
- Configuring Ports for Outgoing/Bi-Directional Connections: Command Line .....26

## Tips on Configuring A Modem

Here are some tips on configuring modems to work with PortServer TS 8/16:

- Configure the modem so that DCD goes high when it receives an incoming connection request.
- Configure the modem to answer an incoming call only when DTR is high, and to drop the line when DTR goes low.
- For bidirectional connections, it is advisable to configure the non-volatile parameters in the modem for incoming calls. Also configure the modem to reset to these parameters when DTR is dropped.
- Configure the modem to lock the serial line speed at the highest baud rate the modem will accept for reliable data transfer because PortServer TS 8/16 cannot switch the baud rate of the serial line on a per call basis without reconfiguration.

**Note:** You may want to consider connecting modems using RealPort, a feature that allows network-based host systems to use the ports of the PortServer TS 8/16 as though they were the host system's own ports. It is an easy and efficient way for modems to use PortServer TS 8/16 ports. For information on this option, see "Configuring Ports for RealPort" on page 15.

## Configuring Ports for Modems: Web Interface

Use this procedure to configure a port for a modem from the web interface.

1. Access the web interface by entering the PortServer TS 8/16 IP address in a browser's URL window.
2. Log in to the PortServer TS 8/16 as root.

The default password is dbps.

3. From the main menu, choose Configure > Ports.
4. To configure a port, do the following:
  - a. Choose the port from the port column.
  - b. Configure the correct device type. Choose Modem in for inbound modem connections, Modem out for out-bound connections, and Modem for bidirectional connections.
  - c. Make other changes to the configuration as required. Use the online help for information.
  - d. If you want to apply this configuration to multiple ports, choose Clone, select the ports for this configuration, and then choose Continue.
  - e. Choose Submit.
5. To return to the main Ports menu, choose Ports from the menu again.

## Configuring Ports for Incoming Modem Connections: Command Line

This section describes how to configure incoming-only modem connections, that is, connections that are initiated by a device across the telephone network.

### Related Information

- If you intend to run PPP traffic over this modem connection, see "Configuring PPP" on page 28.
- For more information on setting the port's flow control attributes see the set flow command in the *Digi One/PortServer TS Command Reference*.
- For information on setting up the port for autoconnection, see "Configuring Autoconnection" on page 38 of this manual and the set ports command in the *Digi One/PortServer TS Command Reference*.
- For information on setting serial line operating parameters such as character size, the number of stop bits, and parity, see the set line command in the *Digi One/PortServer TS Command Reference*.

### Procedure

This procedure assumes that you

- Know the operating parameters required by the modem. If you do not, see the modem documentation.
- Have or will correctly cable the connection between the PortServer TS 8/16 serial ports and modems. See the *Digi One/PortServer Cable Guide* for more information.
- Have logged in as root

1. Supply a set ports command that specifies the following:

```
set ports range=range dev=min
```

where *range* is a PortServer TS 8/16 port or range of ports.

Example: `set ports range=2 dev=min`

2. Supply a set line command that specifies the following:

```
set line range=range baud=bps
```

where *range* is a port or range of ports and *bps* is the line speed for this port.

```
Example: set line range=2 baud=115200
```

3. Supply a set flow command that defines the flow control scheme required by the modem.

### Example

In this example, ports 1 and 2 are set up for incoming modem connections using RTS/CTS flow control.

```
set ports range=1-2 dev=min
set line range=1-2 baud=115200
set flow range=1-2 ixon=off ixoff=off cts=on rts=on
```

## Configuring Ports for Outgoing/Bi-Directional Connections: Command Line

This section describes how to configure outgoing and bidirectional modem connections from the command line.

### Related Information

- For more information on setting the port's flow control attributes see the set flow command in the *Digi One/PortServer TS Command Reference*.
- For information on setting serial line operating parameters such as character size, the number of stop bits, and parity, see the set line command in the *Digi One/PortServer TS Command Reference*.
- For more information on configuring dialer and login scripts, see the set script command in the *Digi One/PortServer TS Command Reference*.

### Before You Begin

This procedure assumes that you

- Know the operating parameters required by the modem. If you do not, see the modem documentation.
- Have or will correctly cable the connection between the PortServer TS 8/16 serial ports and modems. See the *Digi One/PortServer Cable Guide* for more information.
- Logged in as root

### Procedure

1. Supply a set ports command that specifies the following:

```
set ports range=range dev=dev
```

where *range* is a serial port or range of serial ports and *dev* is one of the following:

- dev=mout for outgoing-only connections
- dev=mio for bidirectional connections

**Note:** Use a group number (on the group field), if you intend to create a hunt group of ports that can access a pool of modems. Make sure this group number is greater than 65.

#### Example

```
set ports range=2 dev=mio
```

2. Supply a set line command that specifies the following:

```
set line range=range baud=bps
```

where *range* is a serial port or range of ports and *bps* is the line speed of the connection

**Example**

```
set line range=2 baud=115200
```

3. Supply a set flow command that defines the flow control scheme required by the modem.

**Example**

In this example, ports 1 and 2 are configured for bidirectional modems.

```
set ports range=1-2 dev=mio
```

```
set line range=1-2 baud=115200
```

```
set flow range=1-2 ixon=off ixoff=off rts=on cts=on
```

*Chapter 7*

**Configuring PPP**

**In This Chapter**

This chapter discusses how to configure PPP connections. It covers the following topics:

- Configuring PPP Connections: Web Interface .....29
- Configuring Inbound PPP Connections: Command Line .....29
- Configuring Outbound PPP Connections: Command Line .....31

## Configuring PPP Connections: Web Interface

Use this procedure to configure PPP connections from the web interface.

1. Access the web interface by placing the IP address of the Digi device in the URL window of a browser.
2. Log in as the root user. The default password is dbps.
3. Navigate to the PPP configuration screen, by choosing PPP from the Configure menu.

A screen similar to the following appears.

**Status:** Forwarding is off.

*\*\*If state is in transition, it will take a period of time to reflect your changes.*

Forwarding:  Off  On

Proxy ARP

IP Pool Enabled

IP pool status: IP pool ok

IP pool IP address:

IP pool count:

IP Pool Disabled

### Inbound PPP

1. Configure the port for a modem with the [Ports menu](#).
2. Configure a PPP user with the [User Menu](#).

Use the context-sensitive online help for information on configuration fields.

### Outbound PPP

1. Configure the port for a modem with the [Ports menu](#).
2. If you do **not** want to use the Digi-supplied dialer script (called `genmdm`) and login script (called `loginscript`), which work for most applications, use the [Script Menu](#) to create a new script. **Note:** Login scripts are seldom required. Use them when you are configuring Digi-device-to-Digi Device connections and the Digi device that is to be accessed requires the user to supply a password and does **not** use RADIUS.
3. If you do not want to use the Digi-supplied dialer device (called `gendialer`), which works for most applications, use the [Device Menu](#) to configure a device.
4. Configure a PPP user with the [User Menu](#).

Use the context-sensitive online help for information on configuration fields.

Submit ?

4. Use the web interface and the online help to complete configuration tasks.

## Configuring Inbound PPP Connections: Command Line

Use this section to configure simple inbound PPP connections from the command line. For information on fine-tuning PPP connections, see the `set user` command in the *Digi One/PortServer TS Command Reference*.

**Note:** CHAP authentication works between two Digi devices. CHAP will be negotiated to PAP for all other connections

## Procedure

1. To configure the port for a modem, enter the following command:

```
set ports range=range dev=device
```

where *range* is the port or ports and *device* is one of the following:

- min for inbound only modem connections
- mio for bidirectional modem connections.

See the set ports command in the *Digi One/PortServer TS Command Reference* for more information.

Example: `set ports range=3 device=min`

2. To configure flow control for the ports, enter the following command:

```
set flow range=range flow-control=scheme
```

where *range* is the port or ports and *flow-control=scheme* is the flow control required for this connection. Typically, for modem connections RTS and CTS are on.

Example: `set flow range=3 ixon=off ixoff=off rts=on cts=on`

See the set flow command in the *Digi One/PortServer TS Command Reference* for more information.

3. To configure the baud rate for this connection, enter the following command:

```
set line range=range baud=bps
```

where *range* is the port or ports to configure and *bps* is the line speed in bits-per-second. Typically, you can set this to 115000 bps for modem connections.

Example: `set line range=3 baud=115000`

4. To create an inbound PPP user, enter the following command:

```
set user name=name protocol=ppp netservice=on defaultaccess=netservice
```

where *name* is a name to assign the PPP user

Example:

```
set user name=pppin protocol=ppp netservice=on defaultaccess=netservice
```

5. To configure an IP address for the remote PPP user, enter the following command:

```
set user name=name ipaddr=ip-address
```

where

- *name* is the user's name
- *ip-address* is one of the following: (a) A standard IP address in dotted decimal format. (b) 0.0.0.0, which means the remote user will supply the IP address. (c) ippool, which means that the user will be assigned an IP address from an IP address pool. See the set ippool command in the *Digi One/PortServer TS Command Reference*.

Example: `set user name=pppin ipaddr=ippool`

6. If you used the IP address pool option in the previous step, specify the following subnet mask using the following command: (a mask of 255.255.255.255 is required)

```
set user ipmask=255.255.255.255
```

7. To configure an IP address for the local end of the PPP connection, enter the following command:

```
set user name=name localipaddr=ip-address
```

where *name* is the user's name and *ip-address* is the IP address to assign to the local end of the PPP connection.

tion. This address must be unique. That is, no other user can be assigned this address and it cannot be the IP address for the Ethernet interface.

Example: `set user name=pppin localipadr=199.1.1.2`

### Configuring Inbound PPP Connections: Example

This example shows a very simple PPP inbound configuration. Here are some points on this configuration:

- The port is set up for inbound connections (`dev=min`).
- RTS and CTS are used for flow control.
- The baud rate has been set to 115000 bps.
- The user has been configured to use an IP address pool

```
set ports range=3 device=min
```

```
set flow range=3 ixon=off ixoff=off rts=on cts=on
```

```
set line range=3 baud=115000
```

```
set user name=pppin protocol=ppp netservice=on defaultaccess=netservice
```

```
set user name=pppin ipaddr=ippool
```

```
set user name=pppin localipadr=199.1.1.2
```

### Configuring Outbound PPP Connections: Command Line

This section describes how to configure outbound PPP connections. Use it to configure outbound only connections or to configure the outbound portion of bidirectional connections.

**Note:** CHAP authentication works between two Digi devices. CHAP will be negotiated to PAP for all other connections

#### Procedure

1. To configure the port for a modem, enter the following command:

```
set ports range=range dev=device
```

where *range* is the port or ports and *device* is one of the following:

- `mout` for outbound only modem connections
- `mio` for bidirectional modem connections.

See the `set ports` command in the *Digi One/PortServer TS Command Reference* for more information.

Example: `set ports range=3 device=mout`

2. To configure flow control for the ports, enter the following command:

```
set flow range=range flow-control=scheme
```

where *range* is the port or ports and *flow-control=scheme* is the flow control required for this connection. Typically, for modem connections RTS and CTS are on.

Example: `set flow range=3 ixon=off ixoff=off rts=on cts=on`

See the `set flow` command in the *Digi One/PortServer TS Command Reference* for more information.

3. To configure baud rate for this connection to the modem, enter the following command:

```
set line range=range baud=bps
```

where *range* is the port or ports to configure and *bps* is the line speed in bits-per-second. Typically, you can set this to 115000 bps for modem connections.

Example: `set line range=3 baud=115000`

4. If you do not want to use the Digi-supplied dialer script (`genmdm`) and login script (`loginscript`), which work for most applications, use the `set script` command to create your own scripts.

See the `set script` command in the *Digi One/PortServer TS Command Reference* for more information.

5. If you do not want to use the Digi-supplied outbound device (`gendialer`), which works for most applications, enter the following command:

```
set device name=name ports=ports dialer=name
```

where

- *name=name* is the name for this device
- *ports* are the ports to associate with this device
- *dialer=name* is the name of a dialer script, either the Digi-supplied script or a user-created one

6. To create a PPP user, enter the following command:

```
set user name=name protocol=ppp
```

where *name* is the name of the PPP user

Example

```
set user name=pppout protocol=ppp
```

7. To configure this user for outbound connections, enter the following command:

```
set user name=name outgoing=on device=device
```

where *device* is either the Digi-supplied device or the outbound device created earlier in this procedure

Example:

```
set user name=pppout outgoing=on device=gendialer
```

8. To configure an IP address for the local end of the PPP connection, enter the following command:

```
set user name=name localipaddr=ip-address
```

where *name* is the user's name and *ip-address* is one of the following:

- 0.0.0.0, which means that the user will request an IP address from the remote server.
- A specific IP address, which means that the Digi device will attempt to use this IP address. The remote server must agree to this request.

Example: `set user name=pppout localipadr=0.0.0.0`

9. To configure a telephone number to dial to reach the outbound user, enter the following command:

```
set user name=name n1=telephone-number
```

where *name* is the user's name and *telephone-number* is the number to dial to reach the user. You can enter this number as digits only, with dashes (-) separating digits, or with commas.

Example: `set user name=pppout n1=4452624`

## Example

This example shows a very simple outbound PPP configuration. Here are some points on this configuration:

- The port is set up for outbound connections (dev=mout).
- Hardware flow control is used.
- Default device and scripts are used

```
set ports range=3 device=mout
set flow range=3 ixon=off ixoff=off rts=on cts=on
set line range=3 baud=115000
set user name=pppout protocol=ppp
set user name=pppout dialout=on outgoing=on device=gendialer
set user name=pppout localipadr=0.0.0.0
set user name=pppout nl=4452624
```

set user Field	Description	Example
passpacket	Causes a packet to be passed or blocked	Filter causes incoming packets from an IP address to be accepted and packets from all other IP addresses to be blocked
keepup	Causes the idletimeout timer to be reset and a connection maintained.	Filter that causes the connection to be maintained as long as there is any packet traffic except RIP packets.
bringup	Causes the Digi device to establish a connection.	Filter that causes an outgoing connection to be initiated whenever a packet specifying a particular IP address is handled
logpacket	Causes the Digi device to send a message to the log file	Filter that notifies the log anytime an ICMP packet is handled

Packet Type	Type Identifier
Echo reply	0
Destination unreachable	3
Source quench	4
Redirect	5
Echo request	8
Time exceeded for a datagram	11
Parameter problem on a datagram	12
Timestamp request	13
Timestamp reply	14
Address mask request	17
Address mask reply	18

## Chapter 8

## Configuring IP Routing

**In This Chapter**

This chapter describes how to configure IP routing. It discusses the following topics:

- Configuring Static Routes .....34
- Configuring Dynamic Routes Using RIP.....35
- Configuring Proxy ARP.....36

**Configuring Static Routes**

This section describes how to configure PortServer TS 8/16 for static routes.

**Related Information**

See the `set route` command in the *Digi One/PortServer TS Command Reference*.

**Procedure**

To configure a static route over a PPP link, enter the following command:

```
set route net=addr mask=mask metric=hops wanname=interface gateway=gateway
```

where

- *addr* is either the IP address of a system to be reached over this route or the network address of the subnet that is to be reached on this route
- *mask* is the mask to use for interpreting the IP address.
- *metric* is the number of hop to the destination
- *interface* is either `ether` if this route is over the Ethernet interface or the name of a user if the route is over a PPP link
- *gateway* is the IP address of the device that is the next hop to the destination

**Example: Route Using the Ethernet Interface**

In this example, a route to a subnet is created over the Ethernet interface. Key features include the following:

- The address on the net field is a subnetwork address, not the IP address of a specific device
- The wanname=ether, indicating that this route is over the Ethernet interface
- The metric field indicates that packets to this subnet will pass through two routers
- The gateway field indicates that all packets using this route are to be forwarded to the device at IP address 191.21.21.2.

```
set route net=199.21.33.0 mask=255.255.255.0 metric=2 wannname=ether gateway=199.21.21.2
```

### Example: Route Using a PPP Link

In this example, a route to a subnet is created over a PPP interface. Key features include the following:

- The address on the net field is IP address of a specific device, not a subnetwork address
- The wanname is the name of a PPP user.
- The metric field indicates that packets to this subnet will pass through two routers
- The gateway field indicates that all packets using this route are to be forwarded to the device at IP address 191.21.21.2.

```
set route net=199.21.33.44 mask=255.255.255.255 metric=2 wannname=ppp1 gateway=199.21.21.2
```

## Configuring Dynamic Routes Using RIP

This section describes how to configure PortServer TS 8/16 for dynamic routing.

### Related Information

See the set forwarding command in the *Digi One/PortServer TS Command Reference*.

### Starting Point

This procedure assumes that you have sign on as root and have or will configure modems, modem scripts, devices, and filters for routes that use serial lines.

### Procedure

1. Configure the links over which routed packets and RIP updates will be sent.
  - To enable routing over the LAN to which PortServer TS 8/16 is attached, no routing-specific configuration is required.
  - To enable routing over PPP links be sure to use the netrouting field on the set user command to configure how PortServer TS 8/16 handles RIP updates. You can configure the link so that PortServer TS 8/16 does any of the following with RIP updates:
    - Both sends and receives them (netrouting=both)
    - Sends them only (netrouting=send)
    - Receives them only (netrouting=receive)
    - Neither sends nor receives them (netrouting=off)
2. Configure the PortServer TS 8/16 for dynamic routing with a set forwarding command that specifies state=active.

### Example: Dynamic Routes

In this example, which shows only those commands and command fields pertinent to routing, PortServer TS 8/16 is configured for dynamic routing using RIP. But to prevent RIP updates from being sent across the PPP link, the set user command that defines the link specifies netrouting=off.

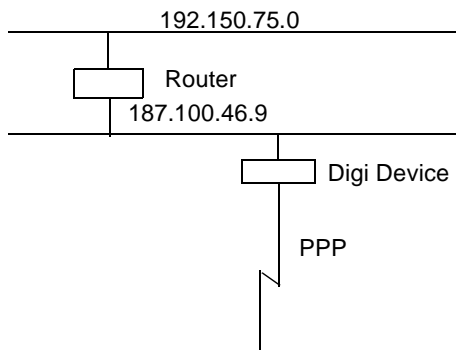

```
set forwarding state=active poisonreverse=on splithorizon=on
set user name=link1...netrouting=off
```

## Configuring Proxy ARP

This section describes how to configure PortServer TS 8/16 for Proxy ARP.

### Related Information

See the `set forwarding` command in the *Digi One/PortServer TS Command Reference*.

### Starting Point

This procedure assumes that you have signed on as root and have or will configure modems, modem scripts, devices, and filters for routes that use serial lines.

### Procedure

1. Configure the links over which packets will be routed using a `set user` command. This command must specify (on the `ipaddr` field) a specific IP address for the remote system using the Proxy ARP service.
2. Configure PortServer TS 8/16 for Proxy ARP by supplying a `set forwarding` command that specifies the following:
  - `state=passive`
  - `proxyarp=on`

**Example**

In this example, PortServer TS 8/16 provides Proxy ARP services to a remote host.

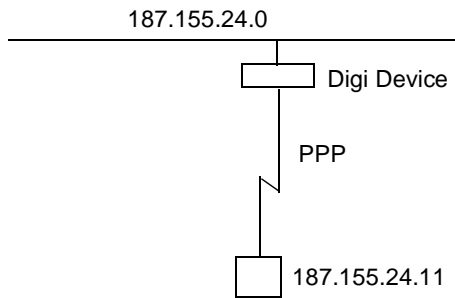

```
set user name=link1...ipaddr=187.155.24.11
set forwarding state=passive proxyarp=on
```

## In This Chapter

This Chapter discusses how to configure the autoconnection feature. It covers the following topics:

- About Autoconnection .....38
- Configuring a Port for Autoconnection: Web Interface .....39
- Configuring Autoconnection By Port: Command Line .....39
- Configuring a User for Autoconnection: Web Interface .....39
- Configuring a User for Autoconnection: Command Line .....40

## About Autoconnection

The autoconnection feature allows you to configure a user to access the PortServer TS 8/16 and then be automatically connected to a host on the LAN. You can implement autoconnection in the following ways:

- By port. In this case, all port users are automatically connected to the same host. The PortServer TS 8/16 is completely transparent to them.
- By user. In this case, a user is required to login and may be required to supply a password, but once the user is authenticated, an automatic connection to a host is made.

## Configuring a Port for Autoconnection: Web Interface

This section describes how to configure a port for autoconnection from the web interface.

1. Access the web interface by entering the PortServer TS 8/16 IP address in a browser's URL window.
2. Log in to the PortServer TS 8/16 as root.

The default password is dbps.

3. Select Configure and then Autoconnect from the menu.
4. Configure the port as required. Use the online help for more information.
5. To return to the main Ports menu, choose Ports from the Menu again.

## Configuring Autoconnection By Port: Command Line

This section describes how to configure a port for autoconnection from the command line.

### Procedure

This procedure describes how to set up a port for autoconnection only. It assumes that you have or will configure the port appropriately for a modem connection (see Chapter 6) or terminal connection (see Chapter 5).

To configure a port to provide automatic connections for all port users, supply a set ports command that specifies the following:

```
set ports range=range auto=on dest=ip-address dport=tcp=port
```

where

- *range* is a port or range of ports
- *ip-address* is the IP address of the host to which the autoconnection should be made
- *tcp-port* is a TCP port to use for this connection

### Example

In this example, port 2 is configured for automatic Telnet connections to a host.

```
set ports range=2 auto=on dest=199.125.123.10 dev=min dport=23
```

## Configuring a User for Autoconnection: Web Interface

1. Access the web interface by entering the PortServer TS 8/16 IP address in a browser's URL window.
2. Log in to the PortServer TS 8/16 as root.

The default password is dbps.

3. Select Configure and then Users from the menu.
4. To add an autoconnect user, do the following:
  - a. Choose Add User.
  - b. Enter a name and then choose Submit
  - c. Choose the new user from the Name column.
  - d. Configure the user. Be sure to specify the following: (1) Default Access: Autoconnect (2) Enable Autoconnect (3) The IP address that will be the destination for the autoconnect user (4) A Destination TCP port number, which determines the type of connection for this user (such as 23 for Telnet).

- e. Choose Submit.
5. To return to the main User menu, choose User from the Menu again.

## **Configuring a User for Autoconnection: Command Line**

This section describes how to configure a user for autoconnection.

### **Procedure**

This procedure deals with autoconnection features only. It assumes that you have or will configure

- The port for modem connections (see Chapter 6) or terminal connections (see Chapter 5)
- Other user attributes (see the set user command in the *Digi One/PortServer TS Command Reference*)

To configure a user to automatically connect to a host, supply a set user command that specifies the following:

```
set user name=user-name ports=ports autoconnect=on autohost=ip-address  
  autoport=tcp-port defaultaccess=autoconnect
```

where

- *user-name* is the name of the user
- *ports* is the ports this user can use
- *ip-address* is the IP address of the host to which the user will be connected
- *tcp-port* is the TCP port to use for connections

### **Example**

In this example, a user is configured for autoconnection using telnet to the host specified. Because the password field is not specified, the default (password=on) requires that the user supply a password before the connection is made.

```
set user name=user4 autoconnect=on autohost=199.193.150.10 autoport=23  
  defaultaccess=autoconnect
```

## Configuring TCP Socket Communication

TCP socket communication enables serial devices--that is, devices that are normally limited to communicating over a dedicated cable--to communicate with each other over an Ethernet network as though they were connected by cable.

This section describes how to use the web interface to configure this Digi device for the following:

- Inbound connections, that is, connections that are initiated by the device on the other side of the network
- Outbound connection, that is, connections that are initiated by the device connected to the serial port

### Procedure for Configuring Inbound Socket Communication

1. Access the web interface by entering the PortServer TS 8/16 IP address in a browser's URL window.
2. Log in to the PortServer TS 8/16 as `root`. The default password is `dbps`.
3. From the main menu, choose `Configure > Port`.
4. From the Port configuration screen, set the Device type to `Printer`, adjust other serial port communication parameters as required by the connected device, and then choose `Submit`.
5. Choose `Advanced`, check `Binary Mode` and then choose `Submit`.

### Procedure for Configuring Outbound Socket Communication

1. Access the web interface by entering the PortServer TS 8/16 IP address in a browser's URL window.
2. Log in to the PortServer TS 8/16 as `root`. The default password is `dbps`.
3. From the main menu, choose `Configure > Port`.
4. From the Port configuration screen, set the Device type to `Modem In`, adjust other serial port communication parameters as required by the connected device, then choose `Submit`.

**Note:** The Terminal type field does not matter.

5. To configure the port to launch an automatic connection, do the following:
  - a. Choose `Advanced`.
  - b. Choose `Enable Autoconnect`
  - c. Specify the IP address of the slave.
  - d. Specify a TCP port to use for this connection. If this is a connection to a serial port on another Digi device and you have not changed the base socket service, use the following conventions to specify a TCP port number:

For This Type of Connection...	Specify ...	Example
Telnet	2000 + port number	To specify port 1, use 2001
Raw connection	2100 + port number	To specify port 2, use 2102

- e. If you want the autoconnection to launch immediately, choose `Force DCD`.
- f. Choose `Binary Mode`.
- g. When you complete configuration, choose `Submit`.

## In This Chapter

- About Console Management.....42
- Configuring Console Management: Web Interface.....42
- Configuring Console Management: Command Line .....43

## About Console Management

PortServer TS 8/16 can be configured to remotely manage network devices, such as routers, switches, and servers, which usually provide EIA-232 serial ports for management. Using the PortServer TS 8/16 and TCP/IP utilities like reverse Telnet and SSH2, network administrators can access consoled serial ports from a single station over the LAN.

## Configuring Console Management: Web Interface

1. Access the web interface by entering the PortServer TS 8/16 IP address in a browser's URL window.
2. Log in to the PortServer TS 8/16 as root.  
The default password is dbps.
3. Select Configure and then Console Management from the menu.
4. Follow the prompts to complete configuration.

## Configuring Console Management: Command Line

This procedure describes how to configure PortServer TS 8/16 to handle console management.

### Procedure

1. For each port connected to a device that will be managed, specify the following:

```
set ports dev=prn range=range
```

where *range* is the port or range of ports to be set up for console management

2. Ensure that the port and the device to be managed are using the same flow control scheme.
  - See the device's documentation for information on flow control requirements.
  - To check the PortServer TS 8/16 current settings and to change them, see description of the set flow command in the *Digi One/PortServer TS Command Reference*.
3. Ensure that the port and the device are using the same baud rate.
  - See the device's documentation for information on baud rate requirements.
  - To check the PortServer TS 8/16 current settings and to change them, see set line description in the *Digi One/PortServer TS Command Reference*.
4. If you want to simplify access to the ports, do one of the following:
  - If the administrator will access the port from a station on the LAN, you can assign IP addresses to each port that will be connected to a managed device, which will allow the administrator to Telnet directly to the port without specifying a port number. See set altip command in the *Digi One/PortServer TS Command Reference* for more information.
  - If you want to use a menu to simplify access, see the examples that follow and the set menu command in the *Digi One/PortServer TS Command Reference* for more information.
5. If you want to use SSH2 connections and use a public key for authentication, do the following:
  - enter the following command

PortServer TS 8	All versions	82000684c or higher
PortServer TS 16		

```
set user name=name loadkey=host:key
```

where

- *name* is the name of a user
- *host* is either an IP address or DNS name of a host running TFTP
- *key* is the name of a file that contains the DSA public key. If your host's implementation requires a complete path to the file, specify the path here as well.

Example: `set user name=secure loadkey=143.191.2.34:ssh-file`

### Example: SSH2 and Menu Access

In this example, a Digi device is configured to use an SSH2 public key, and it presents a menu to the administrator, from which he or she will select a device to manage.

Key aspects of this configuration include the following:

- Two ports to which the managed devices are connected specify dev=prn, a device type that does not spawn a login from the Digi device.
- A menu specifies connect commands, which when selected provide connections to ports 1 and 2 and the managed systems. The menu also specifies a menu table index number of 6 (on the range parameter), which is then linked to a user with the set user command

```
set ports dev=prn range=1-2
set line baud=19200 range=1-2
set menu name=menu1 t1="Console Management Menu" range=6
set menu name=menu1 range=6 name="Console Management Menu" m1="Connect to
  System 1"
set menu name=menu1 range=6 c1="connect 1" m2="Connect to System 2"
set menu name=menu1 range=6 c2="connect 2"
set user name=admin1 defaultaccess=menu menu=6 password=on outgoing=on
set user name=admin1 loadkey=142.191.2.34:ssh-file1
```

### Example: Alternate IP Addresses

#### Configuration

In this example, the PortServer TS 8/16 is configured with

- Alternate IP addresses using set altip commands, which assign IP addresses to ports 1 and 2. This enables direct access to one of these ports with a Telnet command that specifies one of the IP addresses.
- Password protection on ports 1 and 2. This is done with the set auth command.

```
set ports dev=prn range=1-2
set line baud=19200 range=1-2
set auth login=1-2 range=2
set altip group=1 ip=119.180.33.50
set altip group=2 ip=119.180.33.51
```

#### User Command

In this example, a user Telnets to port 1 using an IP address. He/she will be required to log in before access to the port is granted.

```
telnet 119.180.33.50
```

## In This Chapter

This chapter describes PortServer TS 8/16 security features and discusses how to configure them. It presents the following topics:

- Controlling Access to the Configuration .....45
- Controlling Access to Inbound Ports .....46
- Controlling Access to Outbound Ports.....46
- Controlling Access to the Command Line .....47
- Using RADIUS to Authenticate Users.....47
- Issuing User Passwords.....50
- Configuring SSH Version 2 for Secure Communication .....50
- Controlling Access to Services .....52

## Controlling Access to the Configuration

PortServer TS 8/16 restricts access to the configuration by defining the following types of users:

- The root user, who has unlimited access to PortServer TS 8/16 commands. He or she can view any configuration table and change any configuration parameter. The root is identified by the user name root and must supply a password to be authenticated. The default root password is dbps. You should change this password immediately.
- Regular users, who have much more restricted access to PortServer TS 8/16 commands. Regular users can view some configuration tables and can change some configuration parameters related to their own sessions and passwords. See the *Digi One/PortServer TS Command Reference* for information on the limitations placed on regular users for each command.

## Controlling Access to Inbound Ports

This section describes methods of controlling access to inbound serial ports. An inbound port is one defined on the `dev` field of the `set ports` command for one of the following device types:

- `term` (used to define terminal connections)
- `min` (used to define incoming modem connections)
- `mio` (used to define bi-directional modem connections)
- `hdial`, `hio` (used to define computer connections)

### Default Access Restrictions

The default configuration for inbound ports is that a login and password are required to access them.

### Options for Removing Access Restriction

The login and password requirement for inbound ports can be changed by configuring

- The port so that it does not require a login and password. In this case, no one is required to supply a login or password.
- Specific users so that they do not require a password. In this case, some users do not supply passwords, and others are required to.

### Procedure for Changing a Port's Access Requirements

To configure a port so that no one has to login or specify a password, supply a `set logins` command that specifies the following:

```
set logins range=range login=off passwd=off
```

**Example:** `set logins range=1-2 login=off passwd=off`

### Procedure for Changing a User's Access Requirements

To configure a user so that he or she does not have to specify a password when accessing an inbound port, supply a `set user` command that specifies the following:

```
set user name=name password=off
```

where *name* is a name to identify the user

**Example:** `set user name=user1 password=off`

## Controlling Access to Outbound Ports

This section describes methods for controlling access to outbound serial ports. An outbound port is one defined on the `dev` field of the `set ports` command for one of the following device types:

- `prn` (used to define printer connections)
- `mout` (used to define outbound modem connections)
- `mio` (used to define bi-directional modem connections)
- `host` (used to define host connections)

## **Default Access**

The default for outbound ports is unlimited access.

## **Restricting Access to Outbound Ports**

Use the set auth command to restrict access to outbound ports. See the description of the set auth command in the *Digi One/PortServer TS Command Reference* for more information.

## **CHAP Authentication for PPP Users**

CHAP authentication can be used to restrict PPP user access to outbound ports. For more information on CHAP configuration, see the set user command in the *PortServer TS 8/16 Command Reference*.

# **Controlling Access to the Command Line**

This section describes how to restrict access to the PortServer TS 8/16 command line.

## **Method 1 Autoconnection**

The autoconnection feature allows you to configure a user to access the PortServer TS 8/16 but then be automatically connected to a host on the LAN.

You can implement autoconnection in the following ways:

- By port. In this case, all port users are automatically connected to the same host. The PortServer TS 8/16 is completely transparent to them.
- By user. In this case, a user is required to login and may be required to supply a password, but once the user is authenticated, an automatic connection to a hosts made.

For information on configuring autoconnection, see "Configuring Autoconnection" on page 38.

## **Method 2: Menus**

Menus select destination systems without having to access the PortServer TS 8/16 command line. For information on configuring menus, see the description of the set menu command in the *Digi One/PortServer TS Command Reference*.

# **Using RADIUS to Authenticate Users**

This section provides a description of RADIUS and explains how to configure PortServer TS 8/16 to use RADIUS.

## **What is RADIUS?**

RADIUS (remote authentication dial-in user service) is a method of maintaining a database of profiles of dial-in users. These profiles can include login and password information, as well as other user attributes.

## **RADIUS Components**

RADIUS requires two components, an authentication host server and client protocols. The PortServer TS 8/16 implements the client protocol. A host must implement the authentication server application.

## RADIUS Table Key

The numbers in the following tables have the following meaning:

#	Meaning
0	This attribute must <u>not</u> be present.
0+	Zero or more instances of this attribute may be present.
0-1	Zero or one instance of this attribute <u>may</u> be present.
1	Exactly one instance of this attribute <u>must</u> be present.

## RADIUS Attributes (RFC 2138) Supported

The following attributes are supported in the Digi PortServer TS 8/16 RADIUS client implementation.

Request	Accept	Reject	Challenge	#	Attribute
1	0	0	0	1	User-Name
0-1	0	0	0	2	User-Password
0-1	0	0	0	3	CHAP-Password
0-1	0	0	0	4	NAS-IP-Address
0-1	0	0	0	5	NAS-Port
0-1	0-1	0	0	6	Service-Type
0-1	0-1	0	0	7	Framed-Protocol
0-1	0-1	0	0	8	Framed-IP-Address
0-1	0-1	0	0	9	Framed-IP-Netmask
0	0-1	0	0	10	Framed-Routing
0	0+	0	0	11	Filter-Id
0	0-1	0	0	12	Framed-MTU
0+	0+	0	0	13	Framed Compression
0+	0+	0	0	14	Login-IP-Host
0	0-1	0	0	15	Login-Service
0	0-1	0	0	16	Login-TCP-Port
0	0-1	0	0-1	27	Session-Timeout
0	0-1	0	0-1	28	Idle-Timeout

## RADIUS Accounting Attributes (RFC 2139)

The following RADIUS accounting attributes are supported in the Digi PortServer TS 8/16.

#	Attribute	#	Attribute
0-1	User-Name	0-1	Login-TCP-Port
0	User-Password	0-1	Session-Timeout
0	CHAP-Password	0-1	Idle-Timeout
0-1	NAS-IP-Address	1	Acct-Status-Type
0-1	NAS-Port	0-1	Acct-Delay-Time
0-1	Service-Type	0-1	Acct-Input-Octets
0-1	Framed-Protocol	0-1	Acct-Output-Octets
0-1	Framed-IP-Address	1	Acct-Session-Id
0-1	Framed-IP-Netmask	0-1	Acct-Authentic
0-1	Framed-Routing	0-1	Acct-Session-Time
0+	Filter-Id	0-1	Acct-Input-Packets
0-1	Framed-MTU	0-1	Acct-Output-Packets
0+	Framed-Compression	0-1	Acct-Terminate-Cause
0+	Login-IP-Host	0-1	Port-Limit
0-1	Login Service		

### How RADIUS Works

Here is how authentication works when PortServer TS 8/16 is configured for RADIUS:

1. A user logs into PortServer TS 8/16.
2. PortServer TS 8/16 collects login information and then checks to see if the user is in the local database of users.
3. If the user is in the local database, PortServer TS 8/16 handles authentication.
4. If the user is not in the local database, PortServer TS 8/16 submits an authentication request to the RADIUS server.
5. The RADIUS server does one of the following:
  - If the user is validated, it passes this information to other devices and the user is permitted access.
  - If the user is not validated, the RADIUS server returns an access reject message to PortServer TS 8/16, which then denies access to the user.

### Configuring RADIUS: Web Interface

Use this section for information on configuring PortServer TS 8/16 as a RADIUS client from the web interface.

1. Access the web interface by entering the PortServer TS 8/16 IP address in a browser's URL window.
2. Log in to the PortServer TS 8/16 as root.

The default password is dbps.

3. From the main menu, choose Configure > RADIUS.
4. Configure the RADIUS client as required. Use the online help for information on configuration fields.
5. When you complete configuration, choose Submit.

## Configuring RADIUS: Command Line

To configure PortServer TS 8/16 to function as a RADIUS client, supply a `set radius` command that specifies the following:

- `run=on`
- The IP address of the primary RADIUS server (on the `primary` field). The primary server is the first server to which authentication requests are sent.
- A password (on the `secret` field)

### Note

To use a secondary RADIUS server, supply a second `set radius` command that specifies `run=on`, the IP address of the secondary server (on the `secondary` field) and another password for the secondary server (on the `secret` field).

## RADIUS Command Line Configuration Example

```
set radius run=on primary=199.123.15.129 secret=J9CxegepP
```

## Issuing User Passwords

This section discusses how to issue user passwords.

### Related Information

See the `newpass` and `set user` commands in the *Digi One/PortServer TS Command Reference*.

### Starting Point

This procedure assumes that you have signed on as root and already configured the user to whom you will be issuing a password.

### Procedure

1. Issue a `newpass` command that identifies the user (on the `name` field) to whom this password will be issued.
2. When the system prompts you for a new password, type in the password and then press Enter.
3. When the system prompts you to enter the new password again, type it in and then press Enter.

### Example

In this example, the `newpass` command initiates a dialog with PortServer TS 8/16 that results in the user being assigned a password.

```
newpass name=edm1001
```

## Configuring SSH Version 2 for Secure Communication

This section discusses how to configure a user to use SSH version 2 encryption.

### Password Protection

To configure simple password authentication for an SSH user, no SSH-specific configuration is required. Simply configure a user by entering the following commands:

```
set user name=name password=on
```

```
newpass name=name  
where name is a user name
```

**Example**

```
set user name=ssh-user1  
newpass name=ssh-user1
```

**Using a Public Key**

To enable public key authentication and to associate a public key with a user, enter the following command:

```
set user name=name loadkey=host:key
```

where

- *name* is the name of a user
- *host* is either an IP address or DNS name of a host running TFTP that holds
- *key* is the name of a file that contains the DSA public key. If your host's implementation requires a complete path to the file, specify the path here as well.

Example: 

```
set user name=secure loadkey=143.191.2.34:ssh-file
```

**Making Reverse SSH Connections to Ports**

The convention used to identify a port for a reverse SSH connection to a Digi device is to use 2500 + the port number. See the examples that follow for more information.

***Example: Reverse SSH Connection to Port 1***

```
ssh 192.1.2.3 2501
```

***Example: Reverse SSH Connection to Port 4***

```
ssh 192.1.2.3 2504
```

## Controlling Access to Services

This section describes how to disable services, such as Telnet and Rlogin, for inbound users, which means that they cannot access the Digi device using those services. This feature allows you to turn off individual services or to specify a security level, which means that all services not included in that level are turned off.

### Services that Can Be Turned Off

The following services can be turned off.

- HTTP
- RealPort
- Reverse TCP
- Reverse Telnet
- Remote login
- Remote shell
- SNMP
- SSH
- Telnet

### Service Levels

These are the secure access levels:

- Secure, which means that SSH is the only service available to inbound users
- High, which means that SSH, HTTP, SNMP, and RealPort services are available to inbound users
- Normal, which means all services are available
- Custom, which means you can select services to turn off.

The default service level is normal, which means that all services are available.

### Procedure

Use this topic for information on using the web interface to turn services off.

1. Access the PortServer TS 8/16 from a web browser by entering the Digi device's IP address in the URL window.
2. Sign on as root. The default password is dbps.
3. From the main menu, choose Secure Access.
4. Use the wizard to disable services that you do not want to make available to inbound users. Use the context sensitive help for information on configuration fields.

## Chapter 12

# Configuring DNS

## In This Chapter

This chapter discusses how to configure PortServer TS 8/16 to use DNS. Topics discussed include the following:

- About the Domain Name System.....53
- Configuration Procedures .....54

## About the Domain Name System

This section discusses key concepts of the domain name system.

### Purpose of DNS

The domain name system maps domain names to information associated with these names, such as IP addresses.

### DNS Components

DNS components include:

- A distributed database consisting of domain names and associated information
- A hierarchical system of domain name servers that maintain the database and use it to respond to requests for information about a particular domain name, such as its IP address
- Domain name resolvers that
  - Accept requests from users
  - Satisfy information requests by building and submitting properly formulated queries to one or more name servers or by retrieving information from a local host file
  - Return information to users
  - Cache information for future use

### Types of Name Servers

There are two types of name servers in the domain name system:

- Local servers maintain information for resources within a local zone. It is up to individual network adminis-

trators to determine the scope of a local zone.

- Root servers maintain information in higher-level domains than do local servers.

Typically, when a user requires information about a domain name, the resolver queries a local server. If local servers cannot provide the information, root servers are queried next.

## Naming Conventions

Each node in the domain name system has a globally unique domain name that consists of its own name, which is called a label, and the labels of all superior nodes.

## DNS Name Example

Here is an example of a domain name. Note that labels are separated by periods:

mn07.amalgamated.com

In this example, mn07 is part of the higher-level domain called amalgamated.com.

## Configuration Procedures

### Procedure for Using a Name Server

To configure a DNS server, enter the following command:

```
set config domain=domain myname=name dns=ip-address
```

where

- *domain* is the domain in which the PortServer TS 8/16 will reside
- *name* is a DNS name for PortServer TS 8/16
- *ip-address* is the IP address of a name server

Example: `set config domain=digi.com myname=poe dns=204.221.1.4`

### Procedure for Using a Host File

Use this section to configure the host table, which maps IP addresses to host names.

Enter the following command

```
set host name=name ip=ip-address
```

where

- *name* is the name the host
- *ip-address* is the IP address of the host

### Example

In this example, three IP address-to-name mappings are configured

```
set host name=poe ip=204.221.110.200
```

```
set host name=gary ip=204.221.110.202
```

```
set host name=toni ip=204.221.110.203
```

**In This Chapter**

This chapter describes how to configure the PortServer TS 8/16 SNMP agent. It discusses the following topics:

- About SNMP and the PortServer TS 8/16 Agent .....55
- Configuration Procedure: Web Interface .....56

**About SNMP and the PortServer TS 8/16 Agent**

This section introduces SNMP and network management in TCP/IP networks, and it describes the PortServer TS 8/16 agent. It discusses the following:

- Network management components
- The SNMP agent
- SNMP traps
- The PortServer TS 8/16 agent’s MIB support
- The PortServer TS 8/16 agent’s supported traps

**Network Management Components**

The TCP/IP network management architecture contains the following components:

- Managed nodes such as host systems, routers, terminal and communications servers (such as PortServer TS 8/16) and other network devices
- One or more network managers (also called network management stations), which are the points from which the network is managed
- Agents that reside on managed nodes and retrieve management information and communicate this information to network managers
- The network management protocol, SNMP, which governs the exchange of information between the nodes and stations
- Management information, which is the database of information about managed objects. This database is called the management information base (MIB).

## **SNMP Management Agent**

Each managed node contains at least one agent—a component that responds to requests from the network manager—that retrieves network management information from its node and notifies the manager when significant events occur.

## **SNMP Traps**

A mechanism defined by SNMP is called a trap, which is a report or “alarm” from a managed node to an SNMP manager that a significant event has occurred.

## **MIB Support**

The agent supports the following MIBs:

- Read-write for MIB II (RFC 1213), which is an Internet-standard MIB, consisting of managed objects from the systems, interfaces, IP, ICMP, TCP, UDP, transmission, and SNMP group
- Read-write for the character-stream devices using SMIV2 MIB (RFC 1658)
- Read-write for the RS-232-like hardware devices MIB (RFC 1659)
- Read-write for the PortServer TS 8/16 IP Network Control Protocol of the Point-to-Point Protocol MIB (RFC 1473)

## **Message Support**

The SNMP agent supports the Set, Get, GetNext, and Trap messages as defined in RFC 1157. These messages are used as follows:

- Set, which means set the value of a specific object from one of the supported MIBs
- Get, which means retrieve the value of a specific object from one of the supported MIBs
- GetNext, which means retrieve the value of the next object in the MIB
- Trap, which means send traps to the manager when a particular type of significant event occurs

## **Supported Traps**

The agent can send traps when any of the following occur:

- Cold starts (PortServer TS 8/16 initializes)
- Authentication failures
- Login attempts

## **Configuration Procedure: Web Interface**

1. Access the web interface by entering the PortServer TS 8/16 IP address in a browser’s URL window.
2. Log in to the PortServer TS 8/16 as root.

The default password is dbps, which should be changed. See the *newpass* command in the *Digi One/PortServer TS Command Reference* for information on changing passwords.

3. Select Configure and then SNMP from the menu.
4. Fill in the configuration fields and then press Submit.

## In This Chapter

- Upgrading the Firmware .....57
- Copying the Configuration to and from a Remote Host .....58
- Resetting the Configuration to Defaults.....60

## Upgrading the Firmware

This section describes how to upgrade the firmware, which can be done from the web interface using HTTP or FTP.

### Prerequisite Task

**Note:** When upgrading from a firmware release prior to 82000684\_B, the boot code must be upgraded first. To determine your current firmware release, issue the `set config` command. If you need to upgrade the boot code first, here is how you do it:

1. Download the boot code from the Digi web site to a server running TFTP.
2. To load the new boot code, issue the following command:

```
boot load-boot=tftp-server-ip:filename
```

where *tftp-server-ip* is the IP address of the TFTP server and *filename* is the boot file.

Example: `boot load-boot=143.21.10.5:82000679_c1`

3. Reboot the Digi device.

When the Digi device reboots, it is ready for new firmware.

## **HTTP Upgrade Procedure**

1. Download a copy of the latest firmware from the Digi International web site, digi.com.
2. Access the web interface by entering the Digi device IP address in a browser's URL window.
3. Log in to the Digi device as root.

The default password is dbps.

4. From the main menu, choose Admin > HTTP Upgrade.
5. Navigate to the firmware and then choose Submit.
6. Reboot at the prompt.

## **TFTP Upgrade Procedure**

1. Download a copy of the latest Digi device firmware from the Digi International web site, digi.com, and copy it to a host running TFTP.
2. Access the web interface by entering the Digi device IP address in a browser's URL window.
3. Log in to the Digi device as root.

The default password is dbps.

4. From the main menu, choose Admin > TFTP Upgrade.
5. Supply the name of the firmware file, the IP address of the TFTP server, and then choose Submit.
6. Follow the prompts to complete the upgrade.

## **Command Line**

If you want to use the command line to upgrade firmware, use the boot command. See the Digi One/PortServer TS Command Reference for more information.

## **Copying the Configuration to and from a Remote Host**

This section discusses copying the configuration to a remote host and from a remote host, which means you can configure the Digi device remotely by entering commands in a text file and then copying the file to the Digi device.

### **When To Use Remote Configuration**

Typically, you use remote configuration when you have several Digi devices with similar configurations and want to keep a master configuration on a remote host, from which you can easily create variations for downloading to individual Digi devices.

### **Rules for Editing a Configuration file**

Here are some rules for editing a configuration file on a remote host:

- Edit the file with any text editor.
- Each line of the file must start with a set command, such as set user or set line. In other words, do not let commands wrap to the next line if your editor supports this function.
- When downloading a configuration file, Digi device does not notify you of command syntax errors. It simply ignores the command, which means your configuration will not work as expected.

## **HTTP Procedure**

1. Access the web interface by entering the Digi device IP address in a browser's URL window.
2. Log in to the Digi device as root.

The default password is dbps.

3. From the main menu, choose Admin > HTTP CpConf.
4. To copy a file from the host you are on do the following:
  - a. Choose Browse, select the file, and then choose Submit.
  - b. Follow the prompts to complete this procedure.
5. To copy a file to a remote host, do the following:
  - a. Right click on the Download current config link.
  - b. Choose Save Target as
  - c. Specify a file name and then choose Save.
6. Follow the prompts to complete this task.

## **TFTP Procedure**

1. Ensure that TFTP is running on the remote host.
2. Access the web interface by entering the Digi device IP address in a browser's URL window.
3. Log in to the Digi device as root.

The default password is dbps.
4. From the main menu, choose Admin > TFTP CpConf.
5. Choose either Copy configuration to a TFTP server or Copy configuration from a TFTP server.
6. Specify an IP address and a file name and then choose Submit.
7. Follow the prompts to complete this task.

## **Command Line**

If you want to use the command line to copy the configuration to and from a remote host, use the cpconf command. See the *Digi One/PortServer TS Command Reference* for more information.

## Resetting the Configuration to Defaults

Use this topic for information on using the revert command to reset the configuration to factory defaults stored in NVRAM.

**Note:** You can also use the range field on this command to define a range of ports with the serial, port, line, flow, keys and login options.

To Reset the ...	To factory defaults specify ...	To the latest version in NVRAM specify...
Entire configuration	revert all=factory	revert all=nvram
altp configuration	revert altp=factory	revert altp=nvram
arp configuration	revert arp=factory	revert arp=nvram
auth configuration	revert auth=factory	revert auth=nvram
set config configuration	revert config=factory	revert config=nvram
set flow configuration	revert flow=factory	revert flow=nvram
set host configuration	revert host=factory	revert host=nvram
set keysconfiguration	revert keys=factory	revert keys=nvram
set line configuration	revert line=factory	revert line=nvram
set logins configuration	revert login=factory	revert login=nvram
menu configuration	revert menu=factory	revert menu=nvram
altp, arp, host, route, snmp, tcpip, and telnetip	revert network=factory	revert network=nvram
set ports	revert port=factory	revert port=nvram
RADIUS	revert radius=factory	revert radius=nvram
Routing	revert routed=factory	revert routed=nvram
set auth, set logins, and set radius	revert security=factory	revert security=nvram
set flow, set line, set ports	revert serial=factory	revert serial=nvram
set service	revert service=factory	revert service=nvram
SNMP configuration	revert snmp=factory	revert snmp=nvram
set config, set keys, set menu, set service, set terms, set trace, and set user	revert system=factory	revert system=nvram
set tcpip	revert tcpip=factory	revert tcpip=nvram
set telnetip	revert telnetip=factory	revert telnetip=nvram
set terms	revert terms=factory	revert terms=nvram
Trace settings	revert trace=factory	revert trace=nvram
set user	revert users=factory	revert users=nvram

**In This Chapter**

This chapter discusses how to configure users. It covers the following topics:

- About Configuring Users .....61
- Common User Features.....62
- Configuring a User: Web Interface .....62
- Configuring a User: Command Line Examples .....63

**About Configuring Users**

Although it is not required, the PortServer TS 8/16 is often configured to accommodate the requirements of particular users. Typical configurable user attributes include the following:

- Whether the user is required to supply a password
- Autoconnection attributes, such as the system to which the user should be automatically connected at login
- The interface the device presents the user, such as a menu or command line
- Whether the user has access to outbound ports

**Note:** For information on configuring PPP users, see "Configuring PPP" on page 28.

**Configuration Methods**

You can configure users in the following ways:

- With the set user command. See the set user command in the *Digi One/PortServer TS Command Reference*.
- With the web interface.
- With a RADIUS server. See the set radius command in the *Digi One/PortServer TS/Command Reference*.

## Common User Features

This section discusses common user-related features. For a complete list, see the set user command in the *Digi One/PortServer TS Command Reference*.

Feature	Description	set user Field
accesstime	Determines the times and days the user can access the PortServer TS 8/16. This feature is not configurable from the web interface.	accesstime
autoconnect	Automatically connects the user to the host specified on the autohost field using the service (TCP port) defined on the autoport or autoservice fields. Autoconnection can also be implemented by port instead of by user. This feature is configurable from the web interface.	autoconnect autohost autoport autoservice
Default access type	Defines the type of access the user is restricted to. Menu, command line, autoconnect, and outgoing and netservice are the types. This feature is configurable from the web interface.	defaultaccess
Menu access	Defines the menu that is to be presented to a user with menu access. This feature is configurable from the web interface.	menu
Port access	Defines the number of outbound ports a user connected over the LAN can access at one time. This feature is not configurable from the web interface.	maxsessions
PPP	Defines PPP-related parameters for the user.	There are too many fields to list here. See the set user command for more information.
Routing updates	Defines whether RIP routing updates are forwarded over the link to this user.	netrouting

## Configuring a User: Web Interface

Use this section to configure users with from the web interface.

1. Access the web interface by entering the PortServer TS 8/16 IP address in a browser's URL window.
2. Log in to the PortServer TS 8/16 as root.  
The default password is dbps.
3. Select Configure and then Users from the menu.
4. To add a user, do the following:
  - a. Choose Add User.
  - b. Enter a name and then choose Submit
  - c. Choose the new user from the Name column.
  - d. Configure the user as required.
  - e. Choose Submit.
5. To return to the main User menu, choose User from the Menu again.

## Configuring a User: Command Line Examples

This section consists of a set of examples that tell you how to use the set user command to configure various user attributes.

### Configuring a User for a Password

In this example, the set user command configures a new user. The newpass command then initiates a dialog with the PortServer TS 8/16 to assign a password to the new user.

```
set user name=jsmith
  newpass name=jsmith
```

### Configuring a User for a Menu

In this example, the user is configured to use a menu, which is identified by a menu-table index number. If the menu has not been configured, the PortServer TS 8/16 will generate a warning message, but the user will be configured to use the menu, which can then be created later.

```
set user name=jsmith defaultaccess=menu menu=4
```

### Limiting a User's Access to the PortServer TS 8/16

In this example, the user is configured for access to the PortServer TS 8/16 from 9:00 in the morning until 5:00 at night.

```
set user name=jsmith accesstime=wk9:00-17:00
```

### Configuring a User for Autoconnect

In this example, the user is configured to do the following

- Automatically connect to the host identified on the autohost field
- Connect using Telnet

```
set user name=jsmith autoconnect=on defaultaccess=autoconnect
  autohost=191.143.2.17 autoservice=telnet
```

### Displaying an Entry in the User Table

This example assumes that the user named jsmith has already been created, in which case attributes for jsmith are displayed. If the user did not already exist, this command would create a new user named jsmith that uses all default attributes.

```
set user name=jsmith
```

### Removing a User from the User Table

In this example, a user is removed from the user table.

```
remove user name=martymertz
```

This chapter provides several simple, but complete, configuration examples. If you find that the examples implement exactly the features needed for your network, simply copy them, making appropriate substitutions for site-specific information such as IP addresses. Quite likely, however, you will be able to use the examples as a starting point only and will need the information provided in other chapters in this manual and in the *Digi One/PortServer TS Command Reference* to complete your configuration.

## **In This Chapter**

This chapter provides the following discussions:

- Terminal Server Configuration Without RealPort .....65
- Terminal Server Configuration Using Autoconnection .....66
- Terminal Server Configuration Using RealPort.....67

## Terminal Server Configuration Without RealPort

In this configuration, PortServer TS 8/16 acts as a terminal server, providing Telnet and Rlogin access to hosts. This configuration enables the following:

- Telnet or Rlogin access to the LAN-based hosts, both from locally-connected terminals and from devices accessing the LAN from the telephone network
- Access for LAN-based hosts to PortServer TS 8/16 ports (sometimes called reverse Telnet)

### Related Information

For more information on configuring

- The Ethernet interface, see "Configuring the IP Address" on page 11.
- Terminal connections, see "Configuring Ports for Terminals and Computers" on page 21.
- Modem connections, see "Configuring Ports for Modems" on page 24.

### Illustration

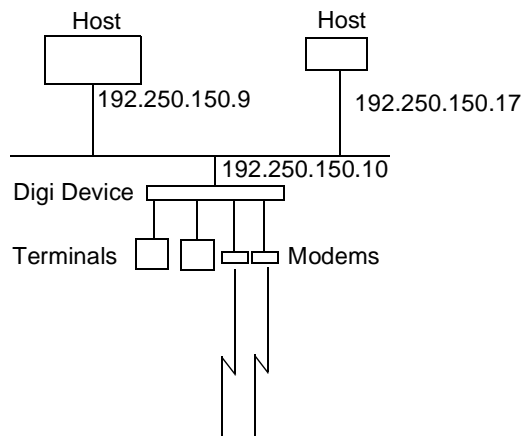

### Configuration

```
set config ip=192.250.150.10 submask=255.255.255.0 (1)
set ports range=1-2 dev=term
set line range=1-2 baud=9600
set flow range=1-2 ixon=on ixoff=on (2)
set ports range=3-4 dev=mio
set line range=3-4 baud=115200
set flow range=3-4 ixon=off ixoff=off rts=on cts=on (3)
set user name=user1(4)
```

### Configuration Notes

1. The set config command configures the IP address and mask for the Ethernet interface.
2. The first set ports, set line, and set flow commands configure ports 1 and 2 for terminal connections.
3. The next set ports, set line and set flow commands configure ports for bidirectional modems. Software flow control (the default) is shut off and hardware flow control turned on using the set flow command.
4. The set user command defines a user, which assigns a user name for login purposes. All PortServer TS 8/16 users can login with this name.

## Terminal Server Configuration Using Autoconnection

This example shows a PortServer TS 8/16 acting as a terminal server implementing autoconnection.

- The terminals are connected to autoconnect ports. Consequently, when a user presses a terminal key, an automatic connection to a host is made.
- The modem ports are not configured for autoconnection, but a port user is, which means that as soon as this particular user supplies a login, an automatic connection to a host is made.

### Related Information

For more information on configuring

- The Ethernet interface, see "Configuring the IP Address" on page 11.
- Terminal connections, see "Configuring Ports for Terminals and Computers" on page 21.
- Modem connections, see "Configuring Ports for Modems" on page 24.

### Illustration

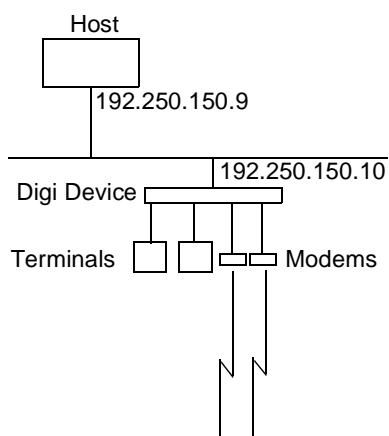

### Configuration

```
set config ip=192.250.150.10 submask=255.255.255.0
set ports range=1-2 dev=term auto=on dest=192.250.150.9 dport=23
set line range=1-2 baud=9600
set flow range=1-2 ixon=on ixoff=on (1)
set ports range=3-4 dev=min
set line range=3-4 baud=115200
set flow range=3-4 ixon=off ixoff=off rts=on cts=on(2)
set user name=user1 autoconnect=on defaultaccess=autoconnect
  autohost=192.250.150.9 autoport=23 password=off (3)
```

### Configuration Notes

1. The first set of set ports, set line and set flow commands configure ports 1 and 2 for terminals, autoconnection, Telnet (dport=23), and software flow control.
2. The second set ports, set line, and set flow commands set up ports 3 and 4 for incoming modem connections and RTS/CTS flow control.
3. The set user command configures the user for automatic connection to the host specified on the autohost field using Telnet (autoport=23).

## Terminal Server Configuration Using RealPort

In this example, the PortServer TS 8/16 is simply providing ports for the LAN-based host using RealPort. The configuration is exceedingly simple because port attributes are configured on the host itself.

### Related Information

For more information on configuring:

- The Ethernet interface, see "Configuring the IP Address" on page 11
- RealPort, see "Configuring Ports for RealPort" on page 15

### Illustration

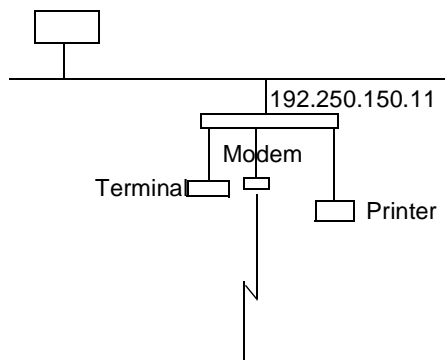

### Configuration

```
set config ip=192.250.150.11 submask=255.255.255.0 (1)
set ports range=2-4 dev=rp(2)
```

### Configuration Notes

1. The set config command configures the internet address and mask for PortServer TS 8/16 Ethernet interface.
2. The set ports command configures ports 2, 3, and 4 for Realport. This command specifies dev=rp, which is an appropriate device type for RealPort.

## Dial-In PPP Connection Using RADIUS

In this configuration, PortServer TS 8/16 uses a RADIUS server to provide a dial-in PPP connection. The attributes of the PPP connection, which can also be specified with set user commands, are specified on the RADIUS server.

### Related Information

For more information on configuring

- Modem connections, see "Configuring Ports for Modems" on page 24.
- Modem scripts, see the set scripts command in the *PortServer TS 8/16 Command Reference*.
- RADIUS, see "Using RADIUS to Authenticate Users" on page 47.

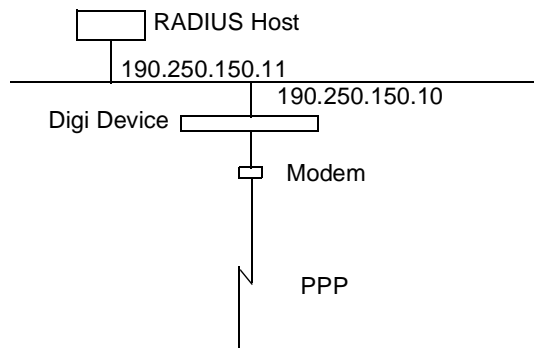

## Configuration

```
set config ip=190.250.150.10
  submask=255.255.255.0

set ports range=9 dev=min
set line range=9 baud=115200
set flow range=9 ixon=off ixoff=off
  rts=on cts=on (1)

set radius primary=190.250.150.11 run=on
  secret=sammy1 (2)
```

## Configuration Notes

1. The set ports, set line and set flow commands configure port 9 for incoming modem connections using RTS/CTS flow control.
2. The set radius command configures PortServer TS 8/16 to use a RADIUS server.

*In This Chapter*

- Symptom: PortServer TS 8/16 Does Not Boot ..... 70
- Symptom: Cannot Telnet to the PortServer TS 8/16.....70
- Symptom: Trouble Accessing a Port.....71
- Running PortServer TS 8/16 Hardware Diagnostics .....71
- Running PortServer TS 8/16 POST .....72
- Verifying TFTP on a UNIX System.....73
- Troubleshooting TFTP Problems .....73
- Resetting PortServer TS 8/16 Configuration to Defaults.....74
- Verifying the PortServer TS 8/16 IP Address .....75
- Checking for Duplicate IP Addresses .....75
- Pinging an IP Address .....75
- Verifying the Network Cabling .....76
- Verifying the RealPort Process .....76
- Checking and Changing Port Configuration .....78
- Digi Contact Information .....79

## Symptom: PortServer TS 8/16 Does Not Boot

### Introduction

Use the information provided in this discussion when PortServer TS 8/16 will not complete the boot cycle.

### Procedures

Things to Try	See ...
Check for hardware problems.	<ul style="list-style-type: none"> <li>"Running PortServer TS 8/16 Hardware Diagnostics" on page 71</li> <li>"Running PortServer TS 8/16 POST" on page 72</li> </ul>
Check for TFTP problems if PortServer TS 8/16 is booting from a TFTP host.	<ul style="list-style-type: none"> <li>"Verifying TFTP on a UNIX System" on page 73</li> <li>"Troubleshooting TFTP Problems" on page 73</li> </ul>
Resetting the device to configuration defaults.	"Resetting PortServer TS 8/16 Configuration to Defaults" on page 74
If you cannot resolve the problem, contact Digi.	"Digi Contact Information" on page 79

## Symptom: Cannot Telnet to the PortServer TS 8/16

### Introduction

Use the information provided in this discussion to troubleshoot network problems.

### Assumptions

This discussion assumes that the PortServer TS 8/16 itself is working, that is, that it completes the boot cycle.

### Procedures

Things to Try	See ...
Verify the IP address. This procedure ensures that you are using the right IP address to Telnet to the PortServer TS 8/16.	"Verifying the PortServer TS 8/16 IP Address" on page 75
Check for duplicate IP address. This procedure ensures that two devices are not using the same IP address.	"Checking for Duplicate IP Addresses" on page 75
See if you can ping the IP address. If you can ping the address, but cannot Telnet to it, you probably have a firewall problem. See the Firewall documentation for more information.	"Pinging an IP Address" on page 75
Verify the network cabling.	"Verifying the Network Cabling" on page 76
If you cannot resolve the problem, contact Digi.	"Digi Contact Information" on page 79

## Symptom: Trouble Accessing a Port

### Introduction

Use this procedure if you are having trouble accessing a PortServer TS 8/16 port. The specific problem might be that you cannot logon from a terminal or the printer or modem is not working properly.

### Assumptions

This discussion assumes the following:

- That the PortServer TS 8/16 itself is working, that is, that it completes the boot cycle. If it is not, see "Symptom: PortServer TS 8/16 Does Not Boot" on page 70.
- That the network is working. This is only pertinent if all ports are not working and the malfunctioning ports are RealPort ports. The discussion in "Symptom: Cannot Telnet to the PortServer TS 8/16" on page 70 goes through the steps of validating the network connection.

### Procedures

Things to Try	See ...
If this is a RealPort port and all ports are not working, ensure that the RealPort process is running.	"Verifying the RealPort Process" on page 76
Verify PortServer TS 8/16 port settings.	"Checking and Changing Port Configuration" on page 78
Verify the cabling to the peripheral	See the Digi One/PortServer Cable Guide for information.

## Running PortServer TS 8/16 Hardware Diagnostics

Use this topic to run hardware diagnostic procedures to validate the PortServer TS 8/16.

1. Connect a terminal to a PortServer TS 8/16 port.
2. If the port is still using the default configuration, configure the terminal to use the following settings (Otherwise, configure the terminal to match the port configuration):
  - VT-100 emulation
  - 9600 baud
  - 8-bit characters
  - 1 stop bit
  - No parity
3. Reboot the PortServer TS 8/16.
4. When the LED begins blinking continuously, press the x key.
5. When the Hardware Diagnostics Menu appears, select a test to perform.

## Running PortServer TS 8/16 POST

Use these topics to run PortServer TS 8/16 power on self test to validate the PortServer TS 8/16 hardware.

### Procedure: Running the POST Using the LEDs

1. Power on the PortServer TS 8/16.
2. Use the following table to interpret the output from the LEDs.

If ...	Then...
The power LED blinks immediately after POST	A DHCP error has occurred and the PortServer TS 8/16 was not assigned an IP address.
Any of the other four LEDs blink immediately after POST,	A hardware component failed.

### Procedure: Running the POST from a Terminal

1. Connect a terminal to the first serial port on the PortServer 8/16.
2. If the port configuration was changed, configure the terminal to match the port settings. If the port is still using the default configuration, configure the terminal to use the following settings:
  - VT-100 emulation
  - 9600 baud
  - 8-bit characters
  - 1 stop bit
  - No parity
3. Reboot the PortServer TS 8/16 and press v when the LEDs begin to blink.  
POST output appears on the terminal screen.

## Verifying TFTP on a UNIX System

Use this procedure to verify that TFTP is working correctly on your UNIX host.

**Note:** This procedure, which uses a TFTP transfer of the Digi Device's boot image between two UNIX hosts, enables you to compare the size of the boot image before and after it is transferred, enabling you to determine if TFTP is working properly.

### Procedure

1. Access a root prompt on the UNIX host.
2. Make sure that you are not in the /tftpboot directory.
3. Enter this command:

```
tftp ipaddress
```

where *ipaddress* is the IP address of the UNIX host.

A TFTP prompt appears.

4. At the prompt, enter the following command:

```
binary
```

5. Enter this command at the TFTP prompt:

```
tftp > get tftp_file_name
```

where *tftp\_file\_name* is the name of the Digi Device's boot image in the /tftpboot directory.

6. Enter this command at the TFTP prompt to exit TFTP:

```
tftp quit
```

7. Compare the size of the original file against the transferred file using this command:

```
ls -l tftp_file_name /tftpboot/tftp_file_name
```

If the file sizes match, TFTP is working properly.

## Troubleshooting TFTP Problems

Here are some things to check if you encounter TFTP problems.

- Verify that the /tftpboot directory exists and has read, write and execute (777) permissions with this command:

```
ls -l /tftpboot
```

If necessary, use this command to create the directory:

```
mkdir /tftpboot
```

- If necessary, use this command to change permissions of the directory to read, write and execute:

```
chmod 777 /tftpboot
```

- ... Verify that the file /tftpboot/ftp\_file\_name exists and has read and execute permissions with this command:

```
ls -l /tftpboot/ftp_file_name
```

where *ftp\_file\_name* is the name of the firmware boot image specified by the Digi Device.

If necessary, use this command to change permissions of the file to read and execute:

```
chmod 666 /tftpboot/ftp_file_name
```

- Verify that the `inetd.conf` file is properly configured for tftp by displaying the file `/etc/inetd.conf`.

An entry similar to this should be uncommented:

```
tftp dgram udp something
```

where *something* will vary with each operating system.

For controlled TFTP access, make sure that the file `/etc/tftpaccess.ctl` exists and verify that it only allows access to public directories. If this file is not present, tftp will allow full access. A sample file is located in the directory `/usr/lpp/tcpip/samples`.

- .....Restart the `inetd` process with these two commands:

```
ps -ef | grep inetd
```

This will report back the `inetd` process number.

```
Kill -1 inetd_PID
```

Where *inetd\_PID* is the process number for the `inetd` process reported by the previous command.

## Resetting PortServer TS 8/16 Configuration to Defaults

Use this topic to reset the PortServer TS 8/16 configuration to defaults.

**Note:** This procedure causes the PortServer TS 8/16 to lose all configuration changes. If you have a complex configuration, see the `cpconf` command in the *Digi One/PortServer TS Command Reference* for information on backing up your configuration.

### Command Line Procedure

1. Log on to the PortServer TS 8/16 as root.
2. Issue the following command:

```
boot action=factory
```

### Front Panel Procedure

1. Power on the PortServer TS 8/16
2. While the PortServer TS 8/16 is still booting, press and hold (for about 10 seconds) the white button on the front panel.

## Verifying the PortServer TS 8/16 IP Address

Use this procedure to check the IP address on the PortServer TS 8/16.

1. Connect a terminal to a PortServer TS 8/16 port.
2. If the port is still using the default configuration, configure the terminal to use the following settings (Otherwise, configure the terminal to match the port configuration):
  - VT-100 emulation
  - 9600 baud
  - 8-bit characters
  - 1 stop bit
  - No parity
3. Press Enter to get a logon prompt from the PortServer TS 8/16.
4. Log on to the PortServer TS 8/16.
5. Use the set config command to verify the PortServer TS 8/16 IP address.

## Checking for Duplicate IP Addresses

Use this procedure to ensure that the PortServer TS 8/16 and another device are not using the same IP address.

### *Procedure*

1. From another system on the network, use the ping command to determine if the IP address is in use. The following is the command syntax:

```
ping ip-address
```
2. Do one of the following:
  - If there is no response to the ping, exit this procedure and return to the symptoms section of this section. Two devices using the same IP address is probably not a problem.
  - If there is a response, continue with this procedure.
3. Turn the PortServer TS 8/16 off and then ping again.
4. Do one of the following:
  - If there is a response to the ping, there is another device using that IP address, so assign one of the devices a new IP address.
  - If there is no response, turn the PortServer TS 8/16. Another device is not using the IP address assigned PortServer TS 8/16.

## Pinging an IP Address

Use this procedure to determine if a system can be reached from across a network.

### *Procedure*

Attempt to ping the PortServer TS 8/16 from another system on the network. Here is the format of the command:

```
ping ip-address
```

## Verifying the Network Cabling

Use this procedure to troubleshoot network cabling problems.

1. Check the Ethernet cable. Verify the following:
  - The Ethernet cable is connected securely at both ends.
  - The Ethernet cable is pinned correctly.
  - The quality of the cable is sufficient for the cable length and the cable environment. Common Category 5 Unshielded Twisted Pair cabling can generally be run 300 meters at a speed of 10 Mbps and 150 meters at higher speeds. Consult an Ethernet cable manufacturer for a recommended cable for your configuration.
2. Verify your Ethernet hub. See your Ethernet hub manual.

## Verifying the RealPort Process

Use one of these procedures to verify the RealPort process:

### AIX: Verifying the RealPort Process

Use this topic to verify that the RealPort daemon (process) is running on the AIX system.

1. Type the following:

```
lsdev -Cc nts
```

2. If the sa devices are not in an available state, type the following from the AIX prompt:

```
mkdev -1 sa#
```

```
cfgmgr
```

where # is the number of the Digi Device.

### HP-UX: Verifying the RealPort Process

1. Verify that RealPort is running on the HP-UX operating system by entering:

```
ps ef | grep drp
```

If you see an entry for each Digi Device similar to the following, the RealPort process is running.

```
root 2254 1 0 Dec 13 ? 0:03/sbin/drpd 1 199.86.0.1 root 2049 1 0 Dec 13 ?
0:01/sbin/drpd 1 199.86.5.1
```

2. If the daemon is not running, enter this command at a root prompt:

```
/usr/sbin/drpadmin
```

3. Answer the prompts as appropriate.

### Linux: Verifying the RealPort Process

The RealPort daemon (process) controls communication between the RealPort driver module and your Digi Devices across the network. One daemon must remain in the background for each Digi Device, maintaining the communication link. You should not need to start the daemon by hand. The `dgrp_cfg_node` program does this automatically.

However, to determine whether any RealPort daemons are currently running on your system, as well as to determine which Digi Device each daemon is communicating with, you can execute the following command:

```
ps ax | grep drpd
```

For more information about the RealPort daemon, see the drpd man page that is installed with the driver package.

### **SCO: Verifying the RealPort Daemon**

Use this topic to verify that the RealPort daemon is running on a SCO Unix or SCO OpenServer operating system.

1. At the root prompt, enter the following command:

```
ps ef | grep ncxd
```

If the RealPort Daemon is running, you should see an entry for each Digi Device similar to the following?

```
root 2254 1 0 Dec 13 ? 0:03/etc/nexd -d /dev/cts0 -n
```

```
root 2049 1 0 Dec 13 ? 0:01/etc/nexd -d /dev/cts0 -n
```

2. If you do not see this information, restart the daemon by doing the following:
  - a. Modify the /etc/rc2.d/S86ncxa file with the appropriate IP addresses.
  - b. Reboot the server.

### **Solaris: Verifying the RealPort Process**

Use this topic for information on verifying that the RealPort process is running on a Solaris system.

1. Type the following command:

```
ps -ef | grep ncxd
```

2. If the information that appears is not correct, do the following:
  - a. Modify the /etc/rc2.d/S26realport file with the appropriate IP addresses.
  - b. Reboot the UNIX server.

### **Windows NT: Verifying the RealPort Service**

Use this procedure to verify the RealPort service on Microsoft Windows NT.

1. From the Start menu, choose Settings > Control Panel > Devices > Digi RealPort.
2. If the RealPort service has not been started, choose Start.

### **Windows 2000: Verifying the RealPort Service**

Use this procedure to verify the RealPort service (process) on Microsoft Windows 2000.

1. Right-click on My Computer, choose Properties > Hardware tab > Device Manager.
2. Expand the Multi-port Serial Adapters list if necessary and select Digi PortServer.
3. If the RealPort Service (process) is not enabled, right-click and choose Enable.

## Checking and Changing Port Configuration

Use this topic to ensure that PortServer TS 8/16 serial port configuration is correct. You can display and change port configuration from either the command line or the web interface. This topic addresses the command line only. For information regarding the web interface, access the port from the web interface and then use the online help.

### *RealPort*

- Specify `set ports dev=rp` to define a device type.
- Configure serial line attributes on the RealPort host.
- Configure flow control on the RealPort host.

### *Printer*

- For most printers, specify `set ports dev=prn`.
- Use the set line command to configure serial line attributes that are consistent with peripheral requirements.
- Use the set flow command to configure flow control attributes that are consistent with peripheral requirements.

### *Incoming Modem*

- For most incoming modem connections, specify `set ports dev=min`.
- Use the set line command to configure serial line attributes that are consistent with peripheral requirements.
- Use the set flow command to configure flow control attributes that are consistent with peripheral requirements.

### *Outgoing Modem*

- For most outgoing modem connections, specify `set ports dev=mout`.
- Use the set line command to configure serial line attributes that are consistent with peripheral requirements.
- Use the set flow command to configure flow control attributes that are consistent with peripheral requirements.

### *Two-way Modem*

- For both incoming and outgoing modem connections, specify `set ports dev=mio`.
- Use the set line command to configure serial line attributes that are consistent with peripheral requirements.
- Use the set flow command to configure flow control attributes that are consistent with peripheral requirements.

### *Terminal*

- For most terminal connections, specify `set ports dev=term`. Also, if you have configured the port for autoconnection, ensure that the destination IP address and TCP port (dport) are correct.
- Use the set line command to configure serial line attributes that are consistent with peripheral requirements.
- Use the set flow command to configure flow control attributes that are consistent with peripheral requirements.

## **Digi Contact Information**

Digi International  
11001 Bren Road East  
Minnetonka, MN 55343  
U.S.A

<b>Customer Service and Support</b>	
World Wide Web:	<a href="http://support.digi.com">http://support.digi.com</a>
email	<a href="mailto:support@digi.com">support@digi.com</a>
Telephone (U.S.)	1-800-344-4273
Telephone (other locations)	(+011) 952-912-3444