



# User Guide

**Digi One/PortServer TS 2/4 W**

90000329\_A

© Digi International Inc., 1998, 2000, 2001, 2002, 2003. All Rights Reserved.

The Digi logo, Connectware logo, RealPort, and PortServer are trademarks or registered trademarks of Digi International. All other brand and product names are trademarks of their respective holders.

<http://www.digi.com>

## Chapter 1 Introduction

Setup Overview .....	9
Step A: Plan.....	9
Step B: Set Up the Hardware .....	9
Step C: Install and Setup Digi Port Authority-Remote .....	9
Step D: Configure an IP Address .....	9
Step E: Configure Ports.....	9
Step F: Configure Other Features as Required.....	9
Step G: Troubleshoot Setup Problems.....	10
About Entering Commands on the Command Line .....	10
Supported Devices .....	10
About This Guide.....	10
Purpose .....	10
Audience.....	10
Scope .....	10
Other Documents in the Library.....	10
Device Server Quick Start Guide.....	11
Digi One/PortServer TS Command Reference.....	11
RealPort Setup Guides.....	11
Digi Port Authority - Remote Device Monitor Setup Guide.....	11
Online Help for the Web UI.....	11
About Configuration Methods.....	11
Configuring the device server from an Attached Terminal .....	11
Configuring the device server from a Telnet Session.....	11
Configuring the device server from the Web Interface .....	11
Downloading a Configuration File.....	11
Configuration Prerequisites .....	12
Accessing the Command Line from a Locally-Connected Terminal .....	12
Log On as Root from the Command Line.....	12
Accessing the Command Line from a Telnet Session.....	12
Accessing the Configuration from the Web Interface .....	12

## Chapter 2 Configuring the IP Address

Options for Configuring the IP Address and Mask .....	13
Device Support: Digi Port Authority-Remote and ARP-Ping for IP Address Configuration .....	13
Configuring the Ethernet Interface with Digi Port Authority-Remote ...	13
Starting Point .....	13
Procedure .....	14
Configuring the IP Address Using ARP-Ping.....	14
Starting Point .....	14
Procedure .....	14
Configuring the Ethernet Interface from the Command Line .....	15
Manual Configuration Procedure.....	15
Example to Set IP Address.....	15
Example to Set Subnet Mask .....	15
Example to Set Gateway Mask .....	15
Manual Configuration Example .....	15

Configuring an IP Address using DHCP and RARP .....	15
About DHCP and RARP .....	15
Procedure .....	16
<b>Chapter 3 Configuring Wireless</b>	
Configuration Considerations .....	17
Install Radio .....	17
Using Ethernet .....	17
<b>Chapter 4 Configuring Ports for RealPort</b>	
About RealPort .....	21
What is RealPort? .....	21
RealPort Advantages .....	21
Configuring the RealPort Software .....	21
Configuration Options .....	21
Configuring Ports: Web Interface .....	21
<b>Chapter 5 Configuring Ports for Printers</b>	
Configuration Considerations .....	23
Using RealPort .....	23
Flow Control Tips .....	23
Using the lpd Protocol .....	23
Configuring Ports for Printers: Web Interface .....	24
Tips for Telnet and rsh Printing .....	24
Configuring a Port for Direct-Access Printing .....	24
Method 1: Specifying Port Numbers in the Telnet Command .....	24
User Command Example 1 .....	25
User Command Example 2 .....	25
Method 1 Configuration .....	25
Method 2: Using Alternate IP Addresses .....	25
Method 2 Configuration .....	25
Command Line Example .....	25
<b>Chapter 6 Configuring Ports for Modems</b>	
Tips on Configuring A Modem .....	27
Configuring Ports for Modems: Web Interface .....	27
Commands for Configuring Ports for Modem Connections .....	27
Related Information .....	28
Configuring A Hunt Group .....	28
Command Line Examples .....	28
<b>Chapter 7 Configuring Ports for Terminals and Computers</b>	
Configuring Ports for Terminals: Web Interface .....	29
Commands for Configuring Ports for Terminals .....	29
Port Defaults .....	29
Related Information .....	29
About Computer Connections .....	29
Starting Point .....	30
Configuring Typical PC Connections .....	30

<b>Chapter 8 Configuring PPP</b>	
Configuring Inbound PPP Connections: Command Line.....	31
Configuring Outbound PPP Connections: Command Line.....	32
<b>Chapter 9 Modem Emulation</b>	
Modem Emulation (Digi One TS and PortServer TS 2/4 MEI only).....	37
Common User Scenarios .....	37
Modem Emulation Cable Signals .....	38
Configuring the Device Server for Modem Emulation: Web Interface.	39
Originating, Answering, and Disconnecting Calls.....	39
Modem Emulation AT Command Set.....	41
S-Registers.....	45
Result Codes.....	49
<b>Chapter 10 Configuring Autoconnection</b>	
About Autoconnection .....	51
Configuring a Port for Autoconnection: Web Interface .....	51
Commands for Configuring Autoconnection by Port or by User.....	51
Configuring a User for Autoconnection: Web Interface .....	51
Configuring TCP Socket Communication.....	52
Configuring UDP Multicast .....	53
<b>Chapter 11 Configuring IP Routing</b>	
Configuring Static Routes.....	57
Related Information .....	57
Procedure .....	57
Example: Route Using the Ethernet Interface .....	57
Example: Route Using a PPP Link.....	57
Configuring Dynamic Routes Using RIP.....	58
Related Information .....	58
Starting Point.....	58
Procedure.....	58
Example: Dynamic Routes .....	58
Configuring Proxy ARP.....	59
Related Information .....	59
Starting Point.....	59
Procedure.....	59
Example.....	59
<b>Chapter 12 Configuring the Digi Device for IA (Industrial Automation)</b>	
Configuring Modbus .....	61
Modbus Configuration Procedure.....	61
Configuring the User-Defined Protocol.....	61
Modbus Configuration Procedure.....	62
<b>Chapter 13 Configuring Security Features</b>	

Controlling Access to the Configuration .....	63
Controlling Access to Inbound Ports .....	63
Default Access Restrictions .....	63
Options for Removing Access Restriction .....	63
Procedure for Changing a Port's Access Requirements .....	63
Example:.....	64
Procedure for Changing a User's Access Requirements .....	64
Example:.....	64
Controlling Access to Outbound Ports.....	64
Default Access.....	64
Restricting Access to Outbound Ports .....	64
CHAP Authentication for PPP Users .....	64
Controlling Access to the Command Line .....	64
Method 1 Autoconnection .....	64
Method 2: Menus .....	65
Issuing User Passwords .....	65
Related Information .....	65
Starting Point .....	65
Procedure .....	65
Configuring SSH Version 2 for Secure Communication .....	65
Password Protection.....	65
Using a Public Key .....	66
Making Reverse SSH Connections to Ports .....	66
Controlling Access to Services .....	66
Services that Can Be Turned Off.....	66
Service Levels .....	67
Procedure .....	67
<b>Chapter 14 Configuring DNS</b>	
About the Domain Name System .....	69
Purpose of DNS.....	69
DNS Components.....	69
Types of Name Servers .....	69
Naming Conventions .....	69
DNS Name Example .....	69
Configuration Procedures.....	70
Procedure for Using a Name Server .....	70
Procedure for Using a Host File .....	70
Example.....	70
<b>Chapter 15 Configuring SNMP</b>	
About SNMP and the device server Agent.....	71
Network Management Components .....	71
SNMP Management Agent.....	71
SNMP Traps .....	71
MIB Support.....	71
Message Support .....	72
Supported Traps .....	72
Configuration Procedure: Web Interface .....	72
<b>Chapter 16 Configuring Users</b>	
About Configuring Users .....	73

Configuration Methods .....	73
Common User Features .....	73
Configuring a User: Web Interface .....	74
Commands for Configuring a User .....	74
<b>Chapter 17 Managing the OS and Configuration</b>	
Upgrading the Firmware .....	75
HTTP or TFTP Upgrade Procedure.....	75
Command Line .....	75
Copying the Configuration to and from a Remote Host.....	75
When To Use Remote Configuration.....	75
Rules for Editing a Configuration file .....	75
HTTP Procedure.....	76
TFTP Procedure .....	76
Command Line .....	76
Resetting Device Server Configuration to Defaults .....	76
Procedure .....	76
Commands for Resetting the Configuration to Defaults .....	77
<b>Chapter 18 Configuring Power Over the Serial Ports</b>	
Serial Power Feature.....	79
Configuring RI Power .....	79
RI Power In.....	79
RI Power Out .....	80
Configuring DTR Power.....	80
Power Out.....	80
Serial Power Table .....	80
<b>Chapter 19 Specifications</b>	
Specifications .....	83
LEDs.....	83
LED Diagnostics .....	83
Device Server EIA 232/422/485 Switch Settings.....	83
DB9 Pinouts.....	84
Standard Models Specifications .....	85
Specifications for Extended Temperature Models.....	86
FCC Part 15 Class A .....	86
Radio Frequency Interference (RFI) (FCC 15.105) .....	86
Labeling Requirements (FCC 15.19) .....	87
Modifications (FCC 15.21).....	87
Cables (FCC 15.27).....	87
ICES 003 Class A.....	87
Digi Contact Information .....	87



## Setup Overview

This section provides an overview of the setup process.

### Step A: Plan

Before beginning setup, consider the following:

- How to assign an IP address to the Digi device's Ethernet interface, which can be accomplished in a number of ways. See "Configuring the IP Address" on page 13.
- How to configure serial ports. A key consideration is whether to use RealPort. Other considerations include the type of peripheral that will connect to the port and the peripheral's cabling requirements. See "Configuring Ports for RealPort" on page 21 and the online RealPort driver documentation and Cable Guide, both of which are on the Access Resource CD.
- The various ways that your Digi device can be configured. See "About Configuration Methods" on page 11 and "Configuration Prerequisites" on page 12 for more information.

### Step B: Set Up the Hardware

1. If the Digi device supports multiple serial port interfaces (EIA-232, EIA-422/485), set the interface with the dip switches on the device.
2. Connect the device to power and to the network.
3. Connect peripherals to serial ports. See the Cable Guide on the Access Resource CD.

### Step C: Install and Setup Digi Port Authority-Remote

Digi Port Authority-Remote is a utility that provides one of the ways to configure an IP address and also provides port monitoring. See the *Digi Port Authority-Remote Device Monitor Setup Guide*, which is on the Access Resource CD.

### Step D: Configure an IP Address

There are a number of ways to configure an IP address. See "Configuring the IP Address" on page 13 for more information.

### Step E: Configure Ports

See the following for more information:

- "Configuring Ports for RealPort" on page 21
- "Configuring Ports for Printers" on page 23
- "Configuring Ports for Modems" on page 27
- "Configuring Ports for Terminals and Computers" on page 29

### Step F: Configure Other Features as Required

See the following for information on setting up other features:

- "Configuring PPP" on page 31
- "Configuring Autoconnection" on page 51
- "Configuring IP Routing" on page 57
- "Configuring Security Features" on page 63
- "Configuring DNS" on page 69

#### **Step G: Troubleshoot Setup Problems**

Troubleshoot problems as required. See "Before contacting Tech Support, check the following:" on page 79.

### **About Entering Commands on the Command Line**

If you use the command line, you will find the commands needed within each chapter. For detail such as syntax, parameters, range, variables, or applications see the Digi One/PortServer TS 2/4 Command Reference found on the Access Resource CD.

### **Supported Devices**

This manual provides information on the following Digi devices:

- Digi One RealPort Wireless
- Digi One TS Wireless
- PortServer TS 2 MEI Wireless
- PortServer TS 4 MEI Wireless

### **About This Guide**

#### **Purpose**

This guide provides the following:

- Configuration and administration procedures
- Configuration examples

#### **Audience**

This manual is intended for the person responsible for configuring and administering device server. It assumes that this person has experience configuring network devices and is familiar with networking concepts.

#### **Scope**

This manual provides step-by-step instructions for configuring and administering device server's main features. It does not address how to configure every option, provide complete information on commands, or discuss hardware installation. These topics are covered in other documents in the device server library.

### **Other Documents in the Library**

Here is a list of the other documents in the library:

### **Device Server Quick Start Guide**

The guide that comes in the package with the device server covering the first steps necessary to get your device server up and running.

### **Digi One/PortServer TS Command Reference**

This online manual, available on the Access Resource CD, provides complete information on commands.

### **RealPort Setup Guides**

These online manuals provide information on setting up servers for RealPort software.

### **Digi Port Authority - Remote Device Monitor Setup Guide**

This online manual provides information on installing and using Digi Port Authority - Remote software.

### **Online Help for the Web UI**

This context-sensitive online help provides information on configuration fields used with web browser configuration interface.

## **About Configuration Methods**

Use this section to learn about configuration methods.

### **Configuring the device server from an Attached Terminal**

With this method, you cable a terminal or PC running terminal emulation software to a device server port and then use the command line to enter commands. This method allows you to configure all features. It requires, however, that you and the device server be in the same location. Some users find it advantageous to configure the device server IP address this way and then use one of the other methods for the rest of the configuration.

### **Configuring the device server from a Telnet Session**

With this method, you Telnet to the device server and use the command line to complete configuration tasks. The only disadvantage to this method is that you have to configure the device server with an IP address before you can Telnet to it.

### **Configuring the device server from the Web Interface**

The great advantage to this method is ease of use. This method requires that you configure the IP address before you can access the configuration from the web interface, however, some features cannot be configured this way.

### **Downloading a Configuration File**

With this method, you configure a Digi device and then do the following:

1. Download an existing configuration file to a host system.
2. Edit the file with specific configuration using a text editor.
3. Upload the file to the device server.

This an excellent method for maintaining highly similar configuration files for multiple Digi devices. The disadvantage is that the device server

requires some configuration steps, such as the IP address, to be completed before it can be used.

## Configuration Prerequisites

### Accessing the Command Line from a Locally-Connected Terminal

Use this procedure to access the command line and the configuration from a terminal connected to one of the device server's serial ports.

1. Connect a terminal or PC to a serial port on the device server. For a Windows HyperTerminal connection, use the cable that came in the package.
2. Configure the parameters of the terminal or terminal emulation software to work with the Digi serial port. The default port settings are:
  - VT 100 emulation
  - 9600 baud
  - 8-bit character
  - 1 stop bit
  - No parity
3. Log on as the `root` user. The default password is `dbps`.

### Log On as Root from the Command Line

1. At the log on prompt, enter `root`.
2. Enter the default password `dbps`.

### Accessing the Command Line from a Telnet Session

Use this procedure to access the command line and the configuration from a Telnet session. This procedure assumes that you have configured the Digi device with an IP address already. See "Configuring the IP Address" on page 13.

1. To Telnet to the device server, enter the following command from a command prompt on another networked device, such as a server:

```
telnet ip-address
```

where *ip-address* is the device server's IP address

Example: `telnet 192.3.23.5`

2. Log on as the `root` user. The default password is `dbps`.

### Accessing the Configuration from the Web Interface

Use this procedure to access the configuration from the web interface. This procedure assumes that you have configured the Digi device with an IP address already. See "Configuring the IP Address" on page 13.

1. Access the device server from a web browser by specifying the device server's IP address in the URL window.
2. Log on as `root`. The default password is `dbps`.

### Options for Configuring the IP Address and Mask

The device server IP address can be configured using the following methods:

- With Digi Port Authority-Remote, a Digi utility
- By updating the ARP table on a server and then pinging the Digi device (called ARP-Ping)
- From the command line using the set config command (Configuring the Ethernet Interface from the Command Line)
- Using a RARP server
- Using a DHCP server

The IP address and mask can also be changed using the web interface. This method, however, does not work for the initial IP address configuration.

#### Device Support: Digi Port Authority-Remote and ARP-Ping for IP Address Configuration

Not all Digi devices can use Digi Port Authority-Remote and ARP-Ping for IP address configuration. To determine if you can use these features, find the hardware label on your Digi device and then use the table below to determine whether this feature is available:

Device	Part Number	Revision Required
Digi One IA RealPort	50000764-01	F or higher
Digi One RealPort	50000723-01	J or higher
PortServer TS 2	50000723-02	J or higher
PortServer TS 4	50000723-03	G or higher

### Configuring the Ethernet Interface with Digi Port Authority-Remote

Use this section to configure an initial IP address, subnet mask, and default gateway using Digi Port Authority-Remote. This procedure cannot be used to change the IP address, but only to assign the initial IP address. It also cannot be used if a DHCP server is active.

#### Starting Point

This procedure assumes the following:

- That your Digi device supports this feature. See "Device Support: Digi Port Authority-Remote and ARP-Ping for IP Address Configuration" on page 13.
- That your Digi device is connected to the Ethernet network.
- That the Digi device has DHCP client turned on. This is the default setting and it will be on unless it was turned off.
- That you do **not** have a DHCP server to serve IP address. If you do, use the DHCP procedure. See "Configuring an IP Address using DHCP and RARP" on page 15.

- That you have installed Digi Port Authority-Remote version 2.01.11 or later. For information on installing Digi Port Authority-Remote, see the *Digi Port Authority Remote Device Monitor Setup Guide*, which is on the Access Resource CD.

#### Procedure

1. Run Digi Port Authority-Remote.
2. If Digi Port Authority-Remote is not set for ADDP, choose ADDP as the Discovery Protocol.
3. Click Discover.

A list of Digi devices appears. Systems with IP addresses of 0.0.0.0 need IP addresses.

4. Select a device from the list and then click Configure.
5. Supply an IP address, subnet mask, and default gateway and then choose OK.

Digi Port Authority-Remote configures the IP address, subnet mask, and default gateway.

## Configuring the IP Address Using ARP-Ping

Use this section to configure an IP address by manually updating a server's ARP table and then pinging the Digi device.

**Note:** The ARP-Ping command assigns the IP address you designate but also assigns default subnet mask and gateway addresses. It is necessary to change the subnet mask and gateway addresses.

#### Starting Point

This procedure assumes the following:

- That your Digi device supports this feature. See "Device Support: Digi Port Authority-Remote and ARP-Ping for IP Address Configuration" on page 13.
- That your Digi device is connected to the Ethernet network

#### Procedure

1. Record the MAC address of the Digi device. It's on the back of the unit.
2. Access a server on the same subnet as the Digi device.
3. Manually update the server's ARP table using the Digi device's MAC address and the IP address you want assigned to the Digi device. The following is an example of how this is done on a Windows NT 4.0 system:

```
arp -s 143.191.2.1 00-00-9d-22-23-60
```

4. Ping the Digi device using the IP address just assigned. The following is an example:

```
ping 143.191.2.1
```

The ping will probably time out before there is a response from the Digi device.

5. Wait a few seconds and then ping the Digi device again.

The Digi device replies to the ping, indicating that the IP address has been configured.

## Configuring the Ethernet Interface from the Command Line

This section discusses how use the command line to configure an IP address, mask, and default gateway for device server's Ethernet interface.

### Manual Configuration Procedure

1. To ensure that the IP address you configure is permanent, turn DHCP off by entering the following command:

```
set config dhcp=off
```

2. To configure an IP address for the Ethernet interface, enter the following command:

```
set config ip=ip-address
```

where *ip-address* is the IP address for the Ethernet interface

### Example to Set IP Address

```
set config ip=191.143.2.154
```

3. To configure a subnet mask, enter the following command:

```
set config submask=mask
```

where *mask* is the subnet mask for this subnetwork

### Example to Set Subnet Mask

```
set config submask=255.255.255.0
```

4. To configure a default gateway, enter the following command:

```
set config gateway=ip-address
```

where *ip-address* is the IP address of the default gateway

### Example to Set Gateway Mask

```
set config gateway=191.143.2.46
```

5. Reboot the Digi device at the prompt using the following command:

```
boot action=reset
```

### Manual Configuration Example

In this example set config commands configure the Ethernet interface and the boot command reboot the Digi device, which is required for the address change to take affect.

```
set config ip=192.150.150.10 submask=255.255.255.0 dhcp=off
```

```
set config gateway=192.150.150.11
```

```
boot action=reset
```

## Configuring an IP Address using DHCP and RARP

### About DHCP and RARP

When the device server boots, it transmits a DHCP request and a RARP request. This continues until an address is assigned.

**Procedure**

To use RARP or DHCP follow these steps:

1. Set up an entry for an address on a DHCP or RARP server. If you intend to use RealPort, do the following:
  - Reserve a permanent IP address.
  - Record the IP address. You will need it when you configure the RealPort driver.
2. Power on the device server.

The DHCP or RARP server assigns the device server an IP address.

### Configuration Considerations

The PortServer TS 4 W works ONLY with the radio provided. You will need an Ethernet cable and a network PC to configure the Wireless device server. After assigning the IP address, access the device from your browser by entering the IP address in the URL address bar.

#### Install Radio

Place your country sticker on the back of the radio.

Slide radio into slot on top of Wireless device server BEFORE connecting any cables or power supply. Only the radio shipped in the box will function with the unit.

Note: Be sure that the grooves on the side of the radio are fit into the notched edges of the Wireless device server. Gently push radio into slot; fit should be snug.

- **WARNING** - DO NOT Plug radio into device server with power connected! The device server does not support 'hot pluggability.' Do not plug or unplug the radio into the device while it is connected to power.

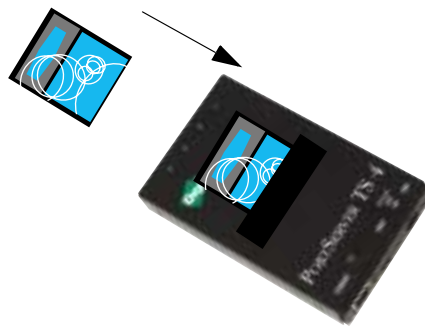

#### Using Ethernet

1. Connect serial cable, Ethernet cable, and power supply.

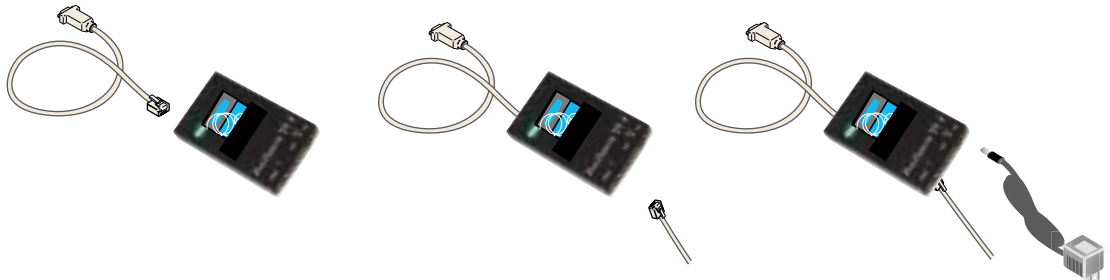

2. Insert CD.
3. Select **Discover Digi Device**.

4. Select the wireless device and assign the IP address.
5. Click **Set IP**.
6. Enter the IP address, Subnet, and Gateway mask and click **OK**.
7. Select the device and click **Configure** to launch your browser.
8. Enter the username **root** and password **dbps** and click **OK**.



9. Click **Configure > Wireless LAN** from the left navigation bar.

10. Enter parameters, click **Submit** to save then click **Advanced**.

**PortServer TS 4 Configuration - Microsoft Internet Explorer**

File Edit View Favorites Tools Help

Back Forward Stop Home Search Favorites History

Address http://192.168.2.2

**Digi**

**Connectware™**

[Setup Wizards](#)  
[Configure](#)  
[Ports](#)  
[Users](#)  
[Menus](#)  
[DHCP](#)  
[Network](#)  
[Wireless LAN](#)  
[Secure Access](#)  
[SNMP](#)  
[Report](#)  
[Admin](#)  
[Log Out](#)

## Wireless Configuration

You are currently connected to My Network with **Low** signal at a **11 Mb** transmit rate. For more information and status, view the [Wireless information and status](#) page.

Choose Submit when you have completed your configuration.

Automatically connect to any available wireless network

Connect to the following wireless network

Network name (SSID):

Network Authentication (Shared Mode)

Data Encryption (WEP Enabled)

Encryption Mode:

Encryption Key:

11. Enter parameters, click **Submit** to save.

PortServer T5 4 Configuration - Microsoft Internet Explorer

File Edit View Favorites Tools Help

Back Forward Stop Refresh Home Search Favorites History

Address http://192.168.2.2

**Digi**

Connectware™

[Setup Wizards](#)  
[Configure](#)  
[Ports](#)  
[Users](#)  
[Menus](#)  
[DHCP](#)  
[Network](#)  
[Wireless LAN](#)  
[Secure Access](#)  
[SNMP](#)  
[Report](#)  
[Admin](#)  
[Log Out](#)

### Wireless Advanced Configuration

Choose Submit when you have completed your configuration.

RTS Threshold:  (0 - 3000)

Fragmentation Threshold:  (256 - 2356, even values)

Density:

Diversity:

Enhanced Transmit Power

Multiplier:

12. Unplug the Ethernet cable from the device server, disconnect the power, and power the unit up (reboot).

Configuration is complete.

## About RealPort

This section provides a brief introduction to RealPort.

### What is RealPort?

RealPort is a feature that allows network-based host systems to use the ports of the device server as though they were the host system's own ports, appearing and behaving as local ports to the network-based host.

### RealPort Advantages

RealPort provides the following advantages:

- It expands the number of ports available to the host system.
- It enables device server ports to be treated as if they were directly connected to the host, which means they use all standard operating system interfaces that control baud rate, parity, stop bits, and flow control.
- It enables host administrators to do most of the required configuration on the host, the system with which the administrator is most familiar.
- It dramatically reduces host CPU overhead because multiple terminal or printer sessions are multiplexed over the same TCP/IP connection.

### Configuring the RealPort Software

You must install and configure RealPort software on each host that will use RealPort ports. See the RealPort documentation for more information.

### Configuration Options

You can configure the device server for RealPort using the web interface. For information on using the web interface, see "Configuring Ports: Web Interface" on page 21.

## Configuring Ports: Web Interface

Use this procedure to configure a port from the web interface.

1. Access the web interface by entering the device server IP address in a browser's URL window.
2. Log on to the device server as `root`.

The default password is `dbps`.

3. From the main menu, select Configure > RealPort.

A screen similar to the following appears.



## RealPort

Connectware™

[Information](#)

**[Configure](#)**

[Ports](#)

[RealPort](#)

[Users](#)

[Menus](#)

[DHCP](#)

[Network](#)

[Port Buffering](#)

[PPP](#)

[RADIUS](#)

[SNMP](#)

[Console Mgmt](#)

[AutoConnect](#)

[Time](#)

[Report](#)

[Admin](#)

[Help](#)

[Logout](#)

RealPort configuration introduction.

The following pages will help you configure a port or ports on this PortServer TS 16 for use with the Digi RealPort driver. This will overwrite any settings you might have changed on any ports you decide to configure. You will also need to configure the RealPort driver on the server you wish to use with this unit.

Next >>

4. To complete configuration, choose Next and then follow the prompts.
5. To return to the main Ports menu, choose Ports from the Menu again.
6. To complete RealPort setup, install and configure the RealPort driver. See the appropriate RealPort setup guide on the Access Resource CD.

## Configuration Considerations

You should be aware of the following considerations if you intend to configure device server to handle printers.

### Using RealPort

RealPort, a feature that allows network-based host systems to use the ports of the device server as though they were the host system's own ports, is an easy and efficient way for printers to use device server ports. For information on this option, see "Configuring Ports: Web Interface" on page 21.

### Flow Control Tips

Here are some tips to ensure that your printer performs as expected:

- If flow control is necessary, ensure that the printer and device server use the same flow control scheme.
- Some printers that use hardware flow control issue the DTR (data terminal ready) signal when they are ready for data. If so, the DTR pin on the cable from the printer must be wired to an input on the device server port (usually CTS) that can be used for flow control.

### Using the lpd Protocol

Here are some tips for configuring the print spooler on your UNIX system when you intend to print using the lpd protocol to a printer attached to device server:

- The number of copies option with lpr is not supported.
- Banner pages are not supported.
- The device server's DNS name or IP address is the remote system's name.
- Queue names must conform to the following conventions:
  - Begin the queue name with one of the following character strings: (a) Use ASCII if you want device server to substitute carriage return and line feed characters for each line feed the system sends. (b) Use raw if no substitution should be performed.
  - After the queue name, insert an underscore character and the number of the device server port to which the printer is attached.
  - If you want to use either of the following options, specify an additional underscore and then the letter that identifies the option: (a) Use **f** to append a form feed character to the end of each file in a print job (b) Use **d** to add a Ctrl-d to the end of each file in a print job. (This is often required by PostScript printers.)

## Examples

String	Result
ascii_1	Prints to port 1 and translates CR to CR/LF.
ascii_8_f	Prints to port 8, translates CR to CR/LF and prints a form feed at the end of the job.
raw_1_d	Prints to port 1 with no translation and appends a Ctrl-d to the end of the print job.

### Configuring Ports for Printers: Web Interface

1. Access the web interface by entering the device server IP address in a browser's URL window.
2. Log on to the device server as `root`. The default password is `dbps`.
3. From the main menu, click Configure > Ports.
4. Choose the port from the port column.
5. Ensure that the Device Type is Printer.
6. Make other changes to the configuration as required. Use the online help for information.
7. If you want to apply this configuration to multiple ports, choose Clone, select the ports for this configuration, and then choose Continue.
8. Click Submit.
9. To return to the main Ports menu, choose Ports from the left navigation bar.

### Tips for Telnet and rsh Printing

Here are some tips for handling Telnet and rsh printing:

- If line feed and carriage return problems occur, try supplying a set line command that specifies `onlcr=on`. This converts carriage returns to carriage return/line feeds.
- If you want tab characters (ASCII character 9) converted to 8 spaces, use a set line command that specifies `otab=on`.

### Configuring a Port for Direct-Access Printing

Direct access printing allows Telnet users on the LAN to access a port and to issue print commands directly to the printer. This section describes the two ways users can access a printer directly and explains how to configure the port to support each method.

#### Method 1: Specifying Port Numbers in the Telnet Command

This method allows users to issue Telnet commands that identify the correct port by using TCP port numbers. Users identify the type of connection and port number by specifying one of the following:

<b>For this connection type...</b>	<b>Identify the port by specifying...</b>
------------------------------------	---

Telnet	2000 plus the number of the port. <b>Example:</b> 2002 for port 2.
Raw	2100 plus the number of the port. <b>Example:</b> 2102 for port 2.

#### User Command Example 1

In this example, a user from the host server, specifies a standard Telnet connection on port 2 of a device server using IP address 199.250.38.15.

```
cat myfile | telnet 199.250.38.15 2002
```

#### User Command Example 2

In this example, a user, from the host server, specifies a raw Telnet connection on port 2 of a device server using IP address 199.250.38.15.

```
cat myfile | telnet 199.250.38.15 2102
```

#### Method 1 Configuration

There is no special configuration required to set up a port for this type of direct access. Simply configure the port for a printer. See "Configuring a Port for Direct-Access Printing" on page 24 for more information.

#### Method 2: Using Alternate IP Addresses

This method provides similar functions to method 1, except it assigns an IP address to a port.

#### Method 2 Configuration

To configure an alternate IP address, do the following:

- Configure the port for a printer. See *Configuring a Port for Direct-Access Printing* on page 24 for more information.
- Supply a set altip command that specifies the following:

```
set altip group=port-number ip=ip-address
```

where

- *port-number* is the actual port number of a device server port
- *IP-address* is the unique IP address of a port on the device server

#### Command Line Example

```
set ports range=2 dev=prn
set line range=2 baud=9600 csize=8 stopb=1 parity=n
set flow range=2 cts=on rts=on ixon=off ixoff=off
set altip group=2 ip=199.250.38.17
```

The following example displays a file on port 2 of a PortServer whose unique IP address is 199.250.38.17:

```
cat myfile | telnet 199.250.38.17
```



### Tips on Configuring A Modem

Here are some tips on configuring modems to work with device server:

- Configure the modem so that DCD goes high when it receives an incoming connection request.
- Configure the modem to answer an incoming call only when DTR is high, and to drop the line when DTR goes low.
- For bidirectional connections, it is advisable to configure the non-volatile parameters in the modem for incoming calls. Also configure the modem to reset to these parameters when DTR is dropped.
- Configure the modem to lock the serial line speed at the highest baud rate the modem will accept for reliable data transfer because the device server cannot switch the baud rate of the serial line on a per call basis without reconfiguration.

Note: You may want to consider connecting modems using RealPort, a feature that allows network-based host systems to use the ports of the device server as though they were the host system's own ports. It is an easy and efficient way for modems to use device server ports. For information on this option, see "About RealPort" on page 21.

### Configuring Ports for Modems: Web Interface

Use this procedure to configure a port for a modem from the web interface.

1. Access the web interface by entering the device server IP address in a browser's URL window.
2. Log on to the device server as `root`. The default password is `dbps`.
3. From the main menu, click Configure > Ports.
4. Click the port from the port column.
5. Configure the correct device type. Click Modem in for inbound modem connections, Modem out for outbound connections, and Modem for bidirectional connections.
6. Make other changes to the configuration as required. Use the online help for information.
7. If you want to apply this configuration to multiple ports, click Clone, select the ports for this configuration, and then click Continue.
8. Click Submit.
9. To return to the main Ports menu, click Ports from the menu again.

### Commands for Configuring Ports for Modem Connections

For configuring ports for modem connections use the following commands found in the *Digi One/PortServer TS Command Reference* :

- `set ports`

- set line
- set flow

#### Related Information

- If you intend to run PPP traffic over this modem connection, see "Configuring PPP" on page 31.
- For information on setting up the port for autoconnection, see "" on page 51 of this manual and the set ports command in the *Digi One/PortServer TS Command Reference*.
- If you do not know the operating parameters required by the modem, see the modem documentation.
- For correct cable information of the connection between the device server serial ports and modems, see the *Digi One/PortServer Cable Guide*.
- For more information on configuring dialer and login scripts, see the set script command in the *Digi One/PortServer TS Command Reference*.

## Configuring A Hunt Group

A hunt group is a group of ports sharing one common IP address and differs from altip where one port has its own unique IP address. A hunt group is desirable when you have many ports, but do not have the available IP addresses or simply prefer to use one IP address for a group of ports. When a user Telnets into the hunt group's IP address and the first port is busy, the user is seamlessly bumped to the next available port.

In configuring the PortServer for a hunt group, the port numbering must start higher than the total number of PortServer serial ports available.

To configure a group of ports for a hunt group, do the following:

1. Enter the following command to create the hunt group:

```
set ports range=range group=port_number
```

2. Enter the following command to set the IP address for the hunt group:

```
set altip group=port_number ipaddress
```

#### Command Line Examples

The following example displays the configuration for 16 serial ports in a hunt group with their collective IP address being 199.250.38.37.

```
set ports range=1-16 group=65
```

```
set altip group=65 ip=199.250.38.37
```

A user who Telnets to this IP address is automatically connected to the first available hunt group port.

### Configuring Ports for Terminals: Web Interface

Use this procedure to configure a port from the web interface.

1. Access the web interface by entering the device server IP address in a browser's URL window.
2. Log on to the device server as `root`. The default password is `dbps`.
3. From the main menu, choose Configure > Ports.
4. Choose the port from the port column.
5. Ensure that the Device type is set to Terminal.
6. Make changes to the configuration as required. Use the online help for information.
7. If you want to apply this configuration to multiple ports, choose Clone, select the ports for this configuration, and then choose Continue.
8. Choose Submit.
9. To return to the main Ports menu, choose Ports from the Menu again.

### Commands for Configuring Ports for Terminals

- `set ports`
- `set line`
- `set flow`

#### Port Defaults

- VT-100 emulation
- 9600 baud
- 8-bit characters
- 1 stop bit
- No parity
- Software flow control

#### Related Information

- For information on the `set line`, `set ports`, and `set flow` commands, see the *Digi One/PortServer TS Command Reference*.
- For information on configuring terminal ports for autoconnections, see, "" on page 51.

**Note:** The `set line` settings must match the settings of the attached terminal or device.

### About Computer Connections

Configuring computer connections is very similar to configuring terminal

connections, which is discussed on page 29. Consequently, this section simply discusses the differences between these connection types.

**Starting Point**

This section assumes that

- You are logged on as root
- You know the attributes, such as baud rate and parity, of the PC that will be connected to this port

**Configuring Typical PC Connections**

To configure a port for a directly-connected PC, where the PC always initiates the connection, configure the connection as you would a terminal connection, except on the set ports command do the following:

- Specify dev=min if you have a 10-pin null modem cable to support this type of connection.
- Specify dev=term if you do not have a 10-pin null modem cable

Consider defining the serial connection as a PPP link. See "Configuring PPP" on page 31 for more information.

## Configuring Inbound PPP Connections: Command Line

Use this section to configure simple inbound PPP connections from the command line. For information on fine-tuning PPP connections, see the set user command in the *Digi One/PortServer TS Command Reference*.

Note: CHAP authentication works between two Digi devices. CHAP will be negotiated to PAP for all other connections

### Procedure

1. To configure the port for a modem, enter the following command:

```
set ports range=range dev=device
```

where *range* is the port or ports and *device* is one of the following:

- min for inbound only modem connections
- mio for bidirectional modem connections.

See the set ports command in the *Digi One/PortServer TS Command Reference* for more information.

Example: `set ports range=3 device=min`

2. To configure flow control for the ports, enter the following command:

```
set flow range=range flow-control=scheme
```

where *range* is the port or ports and *flow-control=scheme* is the flow control required for this connection. Typically, for modem connections RTS and CTS are on.

Example: `set flow range=3 ixon=off ixoff=off rts=on cts=on`

See the set flow command in the *Digi One/PortServer TS Command Reference* for more information.

3. To configure the baud rate for this connection, enter the following command:

```
set line range=range baud=bps
```

where *range* is the port or ports to configure and *bps* is the line speed in bits-per-second. Typically, you can set this to 115000 bps for modem connections.

Example: `set line range=3 baud=115000`

4. To create an inbound PPP user, enter the following command:

```
set user name=name protocol=ppp netservice=on  
defaultaccess=netservice
```

where *name* is a name to assign the PPP user

Example:

```
set user name=pppin protocol=ppp netservice=on  
defaultaccess=netservice
```

5. To configure an IP address for the remote PPP user, enter the following command:

```
set user name=name ipaddr=ip-address
```

where

- *name* is the user's name
- *ip-address* is one of the following: (a) A standard IP address in dotted decimal format. (b) 0.0.0.0, which means the remote user will supply the IP address. (c) *ippool*, which means that the user will be assigned an IP address from an IP address pool. See the `set ippool` command in the *Digi One/PortServer TS Command Reference*.

Example: `set user name=pppin ipaddr=ippool`

6. If you used the IP address pool option in the previous step, specify the following subnet mask using the following command: (a mask of 255.255.255.255 is required)

```
set user ipmask=255.255.255.255
```

7. To configure an IP address for the local end of the PPP connection, enter the following command:

```
set user name=name localipaddr=ip-address
```

where *name* is the user's name and *ip-address* is the IP address to assign to the local end of the PPP connection. This address must be unique. That is, no other user can be assigned this address and it cannot be the IP address for the Ethernet interface.

Example: `set user name=pppin localipadr=199.1.1.2`

### Configuring Inbound PPP Connections: Example

This example shows a very simple PPP inbound configuration. Here are some points on this configuration:

- The port is set up for inbound connections (`dev=min`).
- RTS and CTS are used for flow control.
- The baud rate has been set to 115000 bps.
- The user has been configured to use an IP address pool

```
set ports range=3 device=min
```

```
set flow range=3 ixon=off ixoff=off rts=on cts=on
```

```
set line range=3 baud=115000
```

```
set user name=pppin protocol=ppp netservice=on  
defaultaccess=netservice
```

```
set user name=pppin ipaddr=ippool
```

```
set user name=pppin localipadr=199.1.1.2
```

### Configuring Outbound PPP Connections: Command Line

This section describes how to configure outbound PPP connections. Use it to configure outbound only connections or to configure the outbound portion of bidirectional connections.

Note: CHAP authentication works between two Digi devices. CHAP will be negotiated to PAP for all other connections

## Procedure

1. To configure the port for a modem, enter the following command:

```
set ports range=range dev=device
```

where *range* is the port or ports and *device* is one of the following:

- mout for outbound only modem connections
- mio for bidirectional modem connections.

See the set ports command in the *Digi One/PortServer TS Command Reference* for more information.

Example: `set ports range=3 device=mout`

2. To configure flow control for the ports, enter the following command:

```
set flow range=range flow-control=scheme
```

where *range* is the port or ports and *flow-control=scheme* is the flow control required for this connection. Typically, for modem connections RTS and CTS are on.

Example: `set flow range=3 ixon=off ixoff=off rts=on cts=on`

See the set flow command in the *Digi One/PortServer TS Command Reference* for more information.

3. To configure baud rate for this connection to the modem, enter the following command:

```
set line range=range baud=bps
```

where *range* is the port or ports to configure and *bps* is the line speed in bits-per-second. Typically, you can set this to 115000 bps for modem connections.

Example: `set line range=3 baud=115000`

4. If you do not want to use the Digi-supplied dialer script (genmdm) and login script (loginscript), which work for most applications, use the set script command to create your own scripts.

See the set script command in the *Digi One/PortServer TS Command Reference* for more information.

5. If you do not want to use the Digi-supplied outbound device (gendialer), which works for most applications, enter the following command:

```
set device name=name ports=ports dialer=name
```

where

- *name=name* is the name for this device
- *ports* are the ports to associate with this device
- *dialer=name* is the name of a dialer script, either the Digi-supplied script or a user-created one

6. To create a PPP user, enter the following command:

```
set user name=name protocol=ppp
```

where *name* is the name of the PPP user

Example

```
set user name=pppout protocol=ppp
```

7. To configure this user for outbound connections, enter the following command:

```
set user name=name outgoing=on device=device
```

where *device* is either the Digi-supplied device or the outbound device created earlier in this procedure

Example:

```
set user name=pppout outgoing=on device=gendialer
```

8. To configure an IP address for the local end of the PPP connection, enter the following command:

```
set user name=name localipaddr=ip-address
```

where *name* is the user's name and *ip-address* is one of the following:

- 0.0.0.0. , which means that the user will request an IP address from the remote server.
- A specific IP address, which means that the Digi device will attempt to use this IP address. The remote server must agree to this request.

Example: `set user name=pppout localipadr=0.0.0.0`

9. To configure a telephone number to dial to reach the outbound user, enter the following command:

```
set user name=name n1=telephone-number
```

where *name* is the user's name and *telephone-number* is the number to dial to reach the user. You can enter this number as digits only, with dashes (-) separating digits, or with commas.

Example: `set user name=pppout n1=4452624`

## Example

This example shows a very simple outbound PPP configuration. Here are some points on this configuration:

- The port is set up for outbound connections (dev=mout).
- Flow control is set to Hardware.
- Default device and scripts are used

```
set ports range=3 device=mout
```

```
set flow range=3 ixon=off ixoff=off rts=on cts=on
```

```
set line range=3 baud=115000
```

```
set user name=pppout protocol=ppp
```

```
set user name=pppout dialout=on outgoing=on device=gendialer
```

```
set user name=pppout localipadr=0.0.0.0
```

```
set user name=pppout n1=4452624
```

set user Field	Description	Example
pass-packet	Causes a packet to be passed or blocked	Filter causes incoming packets from an IP address to be accepted and packets from all other IP addresses to be blocked
keepup	Causes the idletimeout timer to be reset and a connection maintained.	Filter that causes the connection to be maintained as long as there is any packet traffic except RIP packets.
bringup	Causes the Digi device to establish a connection.	Filter that causes an outgoing connection to be initiated whenever a packet specifying a particular IP address is handled
logpacket	Causes the Digi device to send a message to the log file	Filter that notifies the log anytime an ICMP packet is handled

Packet Type	Type Identifier
Echo reply	0
Destination unreachable	3
Source quench	4
Redirect	5
Echo request	8
Time exceeded for a datagram	11
Parameter problem on a datagram	12
Timestamp request	13
Timestamp reply	14
Address mask request	17
Address mask reply	18



**Modem Emulation (Digi One TS and PortServer TS 2/4 MEI only)**

Modem emulation enables a system administrator to configure a networked Digi device server to act as a modem. The Digi device server emulates modem responses to a serial device and seamlessly sends and receives data over an Ethernet network instead of a PSTN (Public Switched Telephone Network). The advantage for a user is the ability to retain legacy software applications without modification and use a less expensive Ethernet network in place of public telephone lines.

To use a Digi device server for modem emulation, do the following:

- use a cable with the correct wiring pinouts (see "Modem Emulation Cable Signals" on page 38)
- configure the serial ports and device type with the Web Interface

Note: Before AT commands are accepted, DSR must go high on the Digi device server.

**Common User Scenarios**

The Digi device server in modem emulation mode allows for the easy replacement of modems in almost any environment where there is a LAN or WAN.

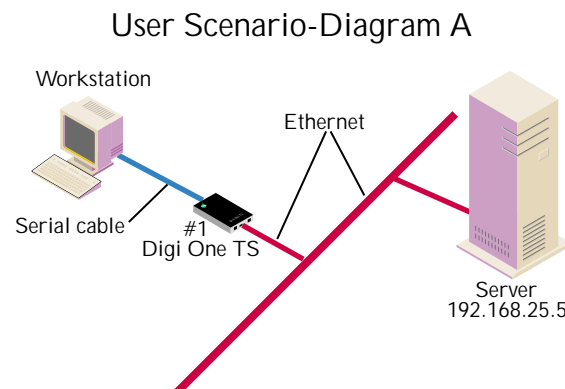

In Diagram A, the Digi One TS replaces a modem connected to a workstation running an application. The Digi One TS allows for the use of software applications without modification by responding to all the AT commands configured in the workstation application. The Digi One TS connects to the IP Address of the server when an `ATDT ipaddress:port` (`ATDT 192.168.25.5:50001`) command is issued. Once the remote device establishes the TCP connection, a `CONNECT` message is sent to the serial port and only then does the Digi device server switch from AT command mode to data mode. Using the modem escape sequence or dropping DTR on either side terminates the connection. A `DISCONNECT` message will be sent to the

application if the remote side closes the TCP connection.

User Scenario-Diagram B

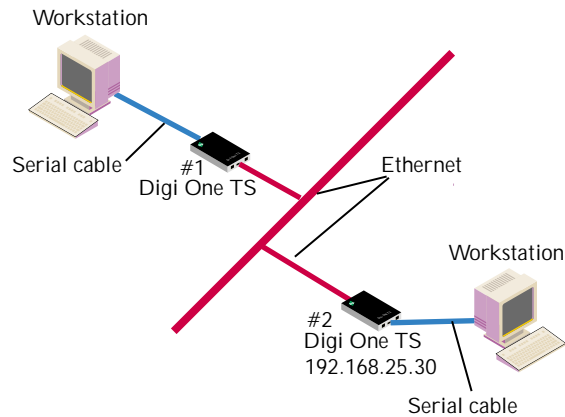

In Diagram B, two Digi device servers will replace modems on both sides of the connection. The initiation of the connection occurs with either of the Digi device servers. If both ends are Digi device servers, the TCP listening port number is 50001 for port 1. An example of the connection command is `ATDT 192.168.25.30:50001`. Upon establishing a successful TCP connection, a `CONNECT` message is sent to the serial port and only then does the Digi device server switch from AT command mode to data mode. After the `CONNECT` is received, the transmission of data begins. Using the modem escape sequence or dropping DTR on either side terminates the connection.

Modem emulation has the ability to communicate to an infinite number of other devices.

### Modem Emulation Cable Signals

Use the following signal assignments to make a cable connecting the Digi device server to a serial device.

Note: DSR and DTR on the serial device side are connected to the DSR signal of the Digi device server.

Serial Device		Digi Device Server
CTS (in)	←	RTS (out)
RTS (out)	← →	CTS (in)
DSR (in)	← →	DSR (in)
DTR (out)	→	
DCD (in)	←	DTR (out)
TX (out)	←	RX (in)
RX (in)	→	TX (out)
GND	—	GND

## Configuring the Device Server for Modem Emulation: Web Interface

Use the following procedure to configure the Digi device server for modem emulation. This procedure configures the serial port parameters and selects the correct Device Type. The following graphic displays a screen capture of this configuration page.

1. Access the web interface by entering the Digi device server's IP address in a browser's URL window.
2. Log on to the device server as `root`. The default password is `dbps`.
3. From the main menu, choose Configure > Ports. The Ports Configuration page is displayed.
4. Choose the port from the port column.
5. Select the Device Type as `pm`.
6. The other port parameters are: flow control=`hardware`, baud rate=`115200`, bits=`8`, parity=`none`, and stop bits=`1`. The terminal type does not apply to this configuration.

Note: Flow control and baud rate must match on the two communicating devices.

7. Choose Submit

Device type:  Baud rate:

Terminal type:  Data bits:

Flow control:  Parity:

Stop bits:

## Originating, Answering, and Disconnecting Calls

In the following table, an application requests a TCP session with the Digi device server. The table displays the responses of the Digi device server and application as they negotiate a TCP connection.

Application AT Command	Digi Device Server Response	Notes
AT&F	OK.	AT command request to restore defaults to factory settings-Digi device server responds OK.
ATDT <i>ipaddress:TCPport#</i>	Receives request to start a TCP session. CONNECT 115200.	Request to start TCP session with IP address and TCP port number of the Digi device server-Digi device server starts a TCP session
<P>+++<P>	OK	Escape sequence is sent <P> is Pause in seconds with "+++" being the escape sequence in ASCII characters - Digi device server switches from AT command to data mode
ATH	NO CARRIER response sent	Disconnect AT command is sent-Digi device server responds with NO CARRIER

In the following table, the Digi device server receives a request for a connection.

AT Command	Digi Device Server Response	Notes
	RING	The Digi device server sends a Call Notification
ATA (or ATS0=n)	CONNECT 115200	Manual (ATA) or Auto Answer (ATS0=n) response-the Digi device server sends a CONNECT message when the TCP session is started
	NO CARRIER	The Digi device server sends a NO CARRIER message when the remote disconnects

### *Originating Calls*

To send data to a Digi device server, enter the following information for your application replacing the telephone number with the Digi device server's IP address and TCP port number. Enter the following command:

```
ATDT ipaddress:tcp_port#
```

an example is ATDT 146.135.13.5:50001

### *Answering Calls*

The Digi device server listens on a pre-defined TCP port to receive data. When the Digi device server receives a call notification (RING) through a serial port to begin a TCP connection, it needs to reply with an ATA or a pre-configured Auto-Answer to answer the call.

Note: The TCP ports assigned to the serial ports are as follows:  
Serial port 1 listens on TCP port 50001  
Serial port 2 listens on TCP port 50002  
Serial port 3 listens on TCP port 50003  
Serial port 4 listens on TCP port 50004

### *Disconnecting Calls*

The TCP connection disconnects by either dropping the DTR signal on the serial port or sending the escape sequence <P>+++<P> to the Digi device server. <P> represents a one second pause.

#### Disconnecting Calls-Digi Device Server

The Digi device server sends a NO CARRIER response to the serial port when the network connection is dropped.

## Modem Emulation AT Command Set

AT Command	Function	Result Code																								
ATA	Answer command: The Digi Device Server will go off hook and answer a TCP connection request.																									
ATD<IP>: <TCP PORT>	<p>This command directs the Digi Device Server to go on-line, dial according to the IP address entered as follow 191.1.2.3:12 and attempt to establish a TCP connection. If no dial string is supplied, the Digi Device Server will respond no dial tone.</p> <p><b>Note:</b> If the ATD command is issued before the S1 register has cleared, the modem will respond with the NO CARRIER result code.</p> <p>Dial Modifiers. The valid dial string parameters are described below. Punctuation characters may be used for clarity with parentheses, hyphen, and spaces being ignored.</p> <table border="1"> <tr> <td>0-9</td> <td>DTMF digits 0 to 9.</td> </tr> <tr> <td>.</td> <td>Dot notation used for IP addresses. IP addresses are written as four numbers separated by periods, where the first number is between 1 and 255 and the other three numbers are between 0 and 255. Retype the IP address in the format xxx.xxx.xxx.xxx .</td> </tr> <tr> <td>:</td> <td>Colon notation used for the TCP port</td> </tr> <tr> <td>L</td> <td>Re-dial last number: the modem will re-dial the last valid telephone number. The L must be immediately after the D with all the following characters ignored.</td> </tr> <tr> <td>P</td> <td>This command is accepted, but not acted on.</td> </tr> <tr> <td>T</td> <td>This command is accepted, but not acted on.</td> </tr> <tr> <td>R</td> <td>This command is accepted, but not acted on.</td> </tr> <tr> <td>S=n</td> <td>Dial the number stored in the directory (n=0 to 3). (See &amp;Z.)</td> </tr> <tr> <td>,</td> <td>Dial pause: the modem will pause for a time specified by S8 before dialing the digits following “,”.</td> </tr> <tr> <td>-</td> <td>Ignored: may be used to format the dial string.</td> </tr> <tr> <td>&lt;space&gt;</td> <td>Ignored: may be used to format the dial string.</td> </tr> <tr> <td>&lt;I&gt;</td> <td>Invalid character: will be ignored.</td> </tr> </table>	0-9	DTMF digits 0 to 9.	.	Dot notation used for IP addresses. IP addresses are written as four numbers separated by periods, where the first number is between 1 and 255 and the other three numbers are between 0 and 255. Retype the IP address in the format xxx.xxx.xxx.xxx .	:	Colon notation used for the TCP port	L	Re-dial last number: the modem will re-dial the last valid telephone number. The L must be immediately after the D with all the following characters ignored.	P	This command is accepted, but not acted on.	T	This command is accepted, but not acted on.	R	This command is accepted, but not acted on.	S=n	Dial the number stored in the directory (n=0 to 3). (See &Z.)	,	Dial pause: the modem will pause for a time specified by S8 before dialing the digits following “,”.	-	Ignored: may be used to format the dial string.	<space>	Ignored: may be used to format the dial string.	<I>	Invalid character: will be ignored.	
0-9	DTMF digits 0 to 9.																									
.	Dot notation used for IP addresses. IP addresses are written as four numbers separated by periods, where the first number is between 1 and 255 and the other three numbers are between 0 and 255. Retype the IP address in the format xxx.xxx.xxx.xxx .																									
:	Colon notation used for the TCP port																									
L	Re-dial last number: the modem will re-dial the last valid telephone number. The L must be immediately after the D with all the following characters ignored.																									
P	This command is accepted, but not acted on.																									
T	This command is accepted, but not acted on.																									
R	This command is accepted, but not acted on.																									
S=n	Dial the number stored in the directory (n=0 to 3). (See &Z.)																									
,	Dial pause: the modem will pause for a time specified by S8 before dialing the digits following “,”.																									
-	Ignored: may be used to format the dial string.																									
<space>	Ignored: may be used to format the dial string.																									
<I>	Invalid character: will be ignored.																									
ATEn	<p>Command echo. The Digi Device Server enables or disables the echo of characters to the DTE according to the parameter supplied. The parameter value, if valid, is written to S14 bit 1.</p> <p>E0 : Disables command echo E1 : Enables command echo</p>	OK n=0 or 1 ERROR otherwise																								
ATH	<p>Disconnect (Hang up) command</p> <p>This command initiates a hang up sequence.</p> <p>H0 : Disconnect the TCP session if the modem is currently on line. H1 : If on-hook, the Digi Device Server will go off-hook and enter command mode.</p>	OK n=0 or 1 ERROR Otherwise																								
ATIn	<p>Identification command</p> <p>I0 reports product code. Example: Digi Device server I1 reports 255 I2 reports “OK” I3 reports “OK” I4 reports DIGI_DS_TS I5 reports “OK” I6 reports “OK” I7 reports “OK” I8 reports “ERROR” I9 reports “ERROR”</p>	OK n=0 or 9 ERROR Otherwise																								

ATLn	Accepted but ignored.	OK n=0 or 3 ERROR Otherwise
ATMn	Accepted but ignored.	OK n=0 or 3 ERROR Otherwise
ATNn	Accepted but ignored.	OK n=0 or 1 ERROR Otherwise
ATOn	Return to On-Line Data Mode. This command determines how the modem will enter the on-line data mode. If the modem is in the on-line command mode, the modem enters the on-line data mode. If the modem is in the off-line command mode (no connection), ERROR is reported. O0 Enters on-line data mode. Handling is determined by the Call Establishment task. Generally, if a connection exists, this command connects the DTE back to the remote modem after an escape (+++). O1 Same as above	OKn = 0 or 1 and a connection exists.  ERROR Otherwise or if not connected.
ATP	Accepted but ignored.	OK
ATQn	Quiet Results Codes Control command. The command enables or disables the sending of the result codes to the DTE according to the parameter supplied. The parameter value, if valid, is written to S14 bit 2. Q0 Enables result code to the DTE (Default). Q1 Disables result code to the DTE	OK n=0 or 1 ERROR Otherwise
ATSn	Read/Write S- Register. n Establishes S-register n as the last register accessed n=v Sets S-Register n to the value v. n? Reports the value of S-Register n.	
ATI	Accepted but ignored..	OK
ATVn	Result Code Form. This command selects the sending of short-form or long-form codes to the DTE. The parameter, if valid, is written to S14 bit 3. V0 Enables short-form (terse) result codes. Line feed is not issues before a short-form result. V1 Enables long-form (verbose) results codes (Default).	OK n=0 or 1 ERROR Otherwise
ATWn	Accepted but ignored.	OK n=0 to 3 ERROR Otherwise
ATXn	Accepted but ignored.	OK n=0 to 3 ERROR Otherwise
ATYn	Accepted but ignored.	OK n=0 or 1 ERROR Otherwise
ATZn	Accepted but ignored. (Soft Reset and restore Profile).	OK n=0 or 1 ERROR Otherwise
AT&Cn	DCD Option. The Digi Device Server controls the DCD output in accordance with the parameter supplied. The parameter value, if valid is written to S21 bit 5. &C0 DCD remains ON at all times. &C1 DCD follows the state of the connection	OK n=0 or 1 ERROR Otherwise

AT&Dn	<p>DTR Option. This command interprets the ON to OFF transition of the DTR signal from the DTE in accordance with the parameter supplied. The parameter value, if valid, is written to S21 bits 3 and 4. Also see S25.</p> <p>&amp;D0 -DTR is ignored (assumed ON). Allows operation with DTEs which do not provide DSR.</p> <p>&amp;D1DTR drop is interpreted by the modem as if the asynchronous escape sequence had been entered. The modem returns to asynchronous command state without disconnecting.</p> <p>&amp;D2DTR drop causes the modem to hang up. Auto-answer is inhibited. (Default.)</p> <p>&amp;D3DTR drop causes the modem to perform a soft reset as if the Z command were received. The &amp;Y setting determines which profile is loaded.</p>	<p>OK n=0 to 3 ERROR Otherwise</p>
AT&Fn	<p>Restore Factory Configuration (Profile)</p> <p>The Device Server loads the factory default configuration (profile). The factory defaults are identified for each command and in the S-Register descriptions. A configuration (profile) consists of a subset of S-Registers.</p> <p>&amp;F0Restore factory configuration 0.</p> <p>&amp;F1Restore factory configuration 1.</p>	<p>OK n=0 or 1 ERROR Otherwise</p>
AT&Jn	Accepted but ignored.	<p>OK n=0 or 1 ERROR Otherwise</p>
AT&Gn	Accepted but ignored.	<p>OK n=0 or 1 ERROR Otherwise</p>
AT&Jn	Accepted but ignored.	<p>OK n=0 or 1 ERROR Otherwise</p>
AT&Kn	<p>Flow control. This command defines the DTE/DCE flow control mechanism. The parameter value, if valid, is written to S39 bits 0, 1, and 2.</p> <p>&amp;K0 Disables flow control</p> <p>&amp;K3 Enables RTS/CTS flow control (Default)</p> <p>&amp;K4 Enables XON/XOFF flow control</p> <p>&amp;K5 Enables transparent XON/XOFF flow control</p> <p>&amp;K6 Enables both RTS/CTS and XON/XOFF flow control.</p>	<p>OK n=0,3,4,5,or 6 ERROR Otherwise</p>
AT&Ln	Accepted but ignored.	<p>OK n=0, 1, 2 ERROR Otherwise</p>
AT&Mn	Accepted but ignored.	<p>OK n=0, 1, 2 ERROR Otherwise</p>
AT&Pn	Accepted but ignored.	<p>OK n=0, 1, 2 ERROR Otherwise</p>
AT&Qn	Accepted but ignored.	<p>OK n=0 to 8 ERROR Otherwise</p>
AT&Rn	<p>RTS/CTS Option</p> <p>This selects how the Digi Device Server controls CTS. CTS is modified if hardware flow control is selected (see &amp;K command). The parameter value, if valid, is written to S21 bit2.</p> <p>&amp;R0CTS reflects the ability of the modem to transmit data. For example, CTS will drop during retrains. In sync mode, CTS tracks the state of RTS; the RTS-to-CTS delay is defined by S26. In async mode, CTS is normally ON and will turn OFF only if required by flow control.</p> <p>&amp;R1CTS forced on (default). In sync mode, CTS is always ON (RTS transitions are ignored). tracks the state of RTS. In async mode, CTS is normally ON and will turn OFF only if required by flow control.</p> <p>&amp;R2CTS follows RTS.</p>	<p>OK n=0 or 1 ERROR Otherwise</p>

AT&Sn	<p>DSR Override</p> <p>This command selects how the modem will control DSR. The parameter value, if valid, is written to S21 bit 6.</p> <p>&amp;S0DSR will remain ON at all times. (Default.)</p> <p>&amp;S1DSR will become active after answer tone has been detected and inactive after the carrier has been lost.</p>	<p>OK n=0 or 1</p> <p>ERROR</p> <p>Otherwise</p>
AT&Tn	Accepted but ignored.	<p>OK n= 0</p> <p>ERROR</p> <p>Otherwise</p>
AT&V	<p>Display Current Configuration and Stored Profiles</p> <p><b>There is no NVRAM support currently.</b></p>	OK
AT&Vn	Accepted but ignored.	<p>OK n=0 to 5</p> <p>ERROR</p> <p>Otherwise</p>
AT&V6	Display current IP settings of the Device Server	OK
AT&Wn	Accepted but ignored.	<p>OK n=0 or 1</p> <p>ERROR</p> <p>Otherwise</p>
AT&Xn	Accepted but ignored.	<p>OK n=0 or 1</p> <p>ERROR</p> <p>Otherwise</p>
AT&Yn	Accepted but ignored.	<p>OK n=0 or 1</p> <p>ERROR</p> <p>Otherwise</p>
AT&Zn	<p>&amp;Zn=x - Store Telephone Number.</p> <p>Currently not supported</p>	<p>OK n=0 or 3</p> <p>ERROR</p> <p>Otherwise</p>
AT\An	Accepted but ignored.	<p>OK n=0 to 3</p> <p>ERROR</p> <p>Otherwise</p>
AT\Gn	Accepted but ignored.	<p>OK n=0 or 1</p> <p>ERROR</p> <p>Otherwise</p>
AT\Kn	Accepted but ignored.	<p>OK n=0 to 5</p> <p>ERROR</p> <p>Otherwise</p>
AT\Nn	<p>Operating Mode</p> <p>This command controls the preferred error correcting mode to be negotiated in a subsequent data connection.</p> <p>\N0Selects normal speed buffered mode</p> <p>\N1Serial interface selected - Selects direct mode</p> <p>\N2Accepted but ignored.</p> <p>\N3Accepted but ignored.</p> <p>\N4Accepted but ignored.</p> <p>\N5Accepted but ignored.</p>	<p>OK n=0 to 5</p> <p>ERROR</p> <p>Otherwise</p>
AT\Vn	Accepted but ignored.	<p>OK n=0 or 1</p> <p>ERROR</p> <p>Otherwise</p>
AT+MS	Accepted but ignored.	OK
AT+MI	Accepted but ignored.	OK
AT%Cn	Accepted but ignored.	<p>OK n=0 to 3</p> <p>ERROR</p> <p>Otherwise</p>

## S-Registers

Register	Function	Range	Units	Saved	Default
S0	Rings to Auto-Answer Sets the number of rings required before the Digi Device Server automatically answers a call. Setting this register to Zero disables auto-answer mode.	0-255	Rings	*	0
S1	Ring Counter S1 is incremented each time the modem detects a ring signal on the telephone line. S1 is cleared if no rings occur over an eight second interval.	0-255	Rings		0
S2	Escape Character S2 holds the decimal value of the ASCII character used as the escape character. The default value corresponds to an ASCII '+'. A value over 127 disables the escape process, i.e., no escape character will be recognized.	0-255	ASCII	*	43
S3	Carriage Return Character Sets the command line and result code terminator character. Pertains to asynchronous operation only.	0-127	ASCII		13
S4	Line Feed Character Sets the character recognized as a line feed. Pertains to asynchronous operation only. The Line Feed control character is output after the Carriage Return control character if verbose result codes are used.	0-127	ASCII		10
S5	Backspace Character Sets the character recognized as a backspace. Pertains to asynchronous operation only. The modem will not recognize the Backspace character if it is set to a value that is greater than 32 ASCII. This character can be used to edit a command line. When the echo command is enabled, the modem echoes back to the local DTE the Backspace character, an ASCII space character and a second Backspace character; this means a total of three characters are transmitted each time the modem processes the Backspace character.	0-32	ASCII		8
S6	Accepted but ignored.	2-255	s	*	2
S7	Accepted but ignored.	1-255	s	*	50
S8	Accepted but ignored.	0-255	s	*	2
S9	Accepted but ignored.	1-255	0.1 s	*	6
S10	Accepted but ignored.	1-255	0.1 s	*	14
S11	Accepted but ignored.	50-255	0.001 s	*	95
S12	Escape Prompt Delay Defines the maximum period, in fiftieths of a second, allowed between receipt of the last character of the three escape character sequence from the DTE and sending of the OK result code to the DTE. If any characters are detected during this time, the OK will not be sent. Note that sending of the OK result code does not affect entry into command mode.	0-255	0.02 s	*	50
S13	Reserved	-	-		-

Register	Function	Range	Units	Saved	Default
S14	General Bit Mapped Options Status Indicates the status of command options. Default:138 (8Ah) (10001010b) Bit 0This bit is ignored. Bit 1Command echo (En) 0 =Disabled (E0) 1 =Enabled (E1) (Default.) Bit 2Quiet mode (Qn) 0 =Send result codes (Q0) (Default.) 1 =Do not send result codes (Q1) Bit 3Result codes (Vn) 0 =Numeric (V0) 1 =Verbose (V1) (Default.) Bit 4Reserved Bit 5Tone (T)/Pulse (P) 0 =Tone (T) (Default.) 1 =Pulse (P) Bit 6Reserved Bit 7Originate/Answer 0 =Answer 1 =Originate (Default.)			*	138 (8Ah)
S15	Reserved	-	-	-	-
S16	Accepted but ignored.	-	-	-	0
S17	Reserved	-	-	-	-
S18	Accepted but ignored.	0-255	s	*	0
S19	Accepted but ignored.	-	-	-	0
S20	Accepted but ignored.	0-255	-	*	0

Register	Function	Range	Units	Saved	Default
S21	<p>General Bit Mapped Options Status Indicates the status of command options. Default:52 (34h) (00110100b) Bit 0Set by &amp;Jn command but ignored otherwise. 0 =&amp;J0 (Default.) 1 =&amp;J1 Bit 1Reserved Bit 2CTS behavior (&amp;Rn) 0 =CTS tracks RTS (&amp;R0) 1 =CTS always on (&amp;R1) (Default.) Bits 3-4DTR behavior (&amp;Dn) 0 =&amp;D0 selected 1 =&amp;D1 selected 2 =&amp;D2 selected (Default.) 3 =&amp;D3 selected Bit 5RLSD (DCD) behavior (&amp;Cn) 0 =&amp;C0 selected 1 =&amp;C1 selected (Default.) Bit 6DSR behavior (&amp;Sn) 0 =&amp;S0 selected (Default.) 1 =&amp;S1 selected Bit 7Long space disconnect (Yn) 0 =Y0 (Default.) 1 =Y1</p>	-	-	*	52 (34h)
S22	Accepted but ignored.	-	-	*	117 (75h)
S23	<p>General Bit Mapped Options Status Indicates the status of command options. Default:62 (3Dh) (00111110b) Bit 0Grant RDL 0 =RDL not allowed (&amp;T5) (Default.) 1 =RDL allowed (&amp;T4) Bits 1-3DTE Rate 0 =0 - 300 bps 1 =600 bps 2 =1200 bps 3 =2400 bps 4 =4800 bps 5 =9600 bps 6 =19200 bps 7 =38400 bps or higher (Default.) Bits 4-5Assumed DTE parity 0 =even 1 =not used 2 =odd 3 =none (Default.) Bits 6-7not action applied</p>			*	62 (3Dh)
S24	Accepted but ignored.	0-255	s	*	0

Register	Function	Range	Units	Saved	Default
S25	Delay to DTR Off Sets the length of time that the modem will ignore DTR for taking the action specified by &Dn. Its units are seconds for synchronous modes and one hundredths of a second for other modes	0-255	s or 0.01 s		5
S26	RTS-to-CTS Delay Sets the time delay, in hundredths of a second, before the modem turns CTS ON after detecting an OFF-to-ON transition on RTS when &R0 is commanded. Pertains to synchronous operation only.	0-255	0.01 s		1
S27	General Bit Mapped Options Status	-	-	*	73 (49h)
S28	Accepted but ignored.	-	-	*	0
S29	Accepted but ignored.	0-255	10 ms		70
S30	Accepted but ignored.	0-255	10 s		0
S31	Accepted but ignored.	-	-	*	194 (C2h)
S32	XON Character	0-255	ASCII		17 (11h)
S33	XOFF Character	0-255	ASCII		19 (13h)
S34	S35 Reserved	-	-		-
S36	Accepted but ignored.	-	-	*	7
S37	Accepted but ignored.	-	-	*	0
S38	Accepted but ignored.	0-255	s		20
S39	Flow Control Bit Mapped Options Status Default:3 (0000011b) Bits 0-2Status of command options 0 =No flow control 3 =RTS/CTS (&K3) (Default.) 4 =XON/XOFF (&K4) 5 =Transparent XON (&K5) 6 =Both methods (&K6) Bits 3-7Reserved	-	-	*	3
S40	Accepted but ignored.	-	-	*	104 (68h)
S41	Accepted but ignored.	-	-	*	195 (C3h)
S42 - S45	Reserved	-	-		-
S46	Accepted but ignored.	-	-	*	138
S48	Accepted but ignored.	-	-	*	7
S82	Accepted but ignored.	-	-		128(40h)
S86	Accepted but ignored.	0-255	-		-
S91	Accepted but ignored.	0-15	dBm		10 (Country dependent)
S92	Accepted but ignored.	0-15	dBm		10 (Country dependent)
S95	Accepted but ignored.	-	-	*	0

\* Register value may be stored in one of two user profiles with the &W command.

## Result Codes

Short	Long Form		Short	Long Form		Short	Long Form
0	OK		13	CONNECT 7200		84	CONNECT 33600
1	CONNECT		14	CONNECT 12000		91	CONNECT 31200
2	RING		15	CONNECT 14400		165	CONNECT 32000
3	NO CARRIER		16	CONNECT 19200		166	CONNECT 34000
4	ERROR		17	CONNECT 38400		167	CONNECT 36000
5	CONNECT 1200		18	CONNECT 57600		168	CONNECT 38000
6	NO DIALTONE		19	CONNECT 115200		169	CONNECT 40000
7	BUSY		20	CONNECT 230400		170	CONNECT 42000
8	NO ANSWER		59	CONNECT 16800		171	CONNECT 44000
9	CONNECT 0600		61	CONNECT 21600		172	CONNECT 46000
10	CONNECT 2400		62	CONNECT 24000		173	CONNECT 48000
11	CONNECT 4800		63	CONNECT 26400		174	CONNECT 50000
12	CONNECT 9600		64	CONNECT 28800			



### About Autoconnection

The autoconnection feature allows you to configure a user to access the device server and then be automatically connected to a host on the LAN. You can implement autoconnection in the following ways:

- By port where all port users are automatically connected to the same host. The device server is completely transparent to them.
- By user where a user is required to log on and may be required to supply a password, but once the user is authenticated, an automatic connection to a host is made.

### Configuring a Port for Autoconnection: Web Interface

This section describes how to configure a port for autoconnection from the web interface.

1. Access the web interface by entering the device server IP address in a browser's URL window.
2. Log on to the device server as `root`. The default password is `dbps`.
3. Select Configure and then Autoconnect from the menu.
4. Configure the port as required. Use the online help for more information.
5. To return to the main Ports menu, choose Ports from the Menu again.

### Commands for Configuring Autoconnection by Port or by User

See the complete list of commands in the *Digi One/PortServer TS Command Reference*. The commands needed for autoconnection either by port or by user will be under the following commands in the Command Reference on your Access Resource CD.

- `set ports`
- `set user`

### Configuring a User for Autoconnection: Web Interface

1. Access the web interface by entering the device server IP address in a browser's URL window.
2. Log on to the device server as `root`. The default password is `dbps`.
3. Select Configure and then Users from the menu.
4. Choose Add User.
5. Enter a name and then choose Submit
6. Choose the new user from the Name column.
7. Configure the user. Be sure to specify the following: (1) Default Access: Autoconnect (2) Enable Autoconnect (3) The IP address that will be the destination for the autoconnect user (4) A Destination TCP port number,

which determines the type of connection for this user (such as 23 for Telnet).

8. Choose Submit.
9. To return to the main User menu, choose User from the Menu again.

Note:

## Configuring TCP Socket Communication

TCP socket communication enables serial devices to communicate with each other over an Ethernet network as though they were connected by a serial cable.

This section describes how to use the web interface to configure this Digi device for the following:

- Inbound connections, that is, connections that are initiated by the device on the other side of the network
- Outbound connection, that is, connections that are initiated by the device connected to the serial port

### Procedure for Configuring Inbound Socket Communication

1. Access the web interface by entering the device server IP address in a browser's URL window.
2. Log on to the device server as `root`. The default password is `dbps`.
3. From the main menu, choose Configure > Port.
4. From the Port configuration screen, set the Device type to Printer, adjust other serial port communication parameters as required by the connected device, and then choose Submit.
5. Choose Advanced, check Binary Mode and then choose Submit.

### Procedure for Configuring Outbound Socket Communication

1. Access the web interface by entering the device server IP address in a browser's URL window.
2. Log on to the device server as `root`. The default password is `dbps`.
3. From the main menu, choose Configure > Port.
4. From the Port configuration screen, set the Device type to Modem In, adjust other serial port communication parameters as required by the connected device, then choose Submit.

Note: The Terminal type field does not matter.

5. To configure the port to launch an automatic connection, choose Advanced.
6. Choose Enable Autoconnect
7. Specify the IP address of the slave.
8. Specify a TCP port to use for this connection. If this is a connection to a serial port on another Digi device and you have not changed the base

socket service, use the following conventions to specify a TCP port number:

For This Type of Connection...	Specify ...	Example
Telnet	2000 + port number	To specify port 1, use 2001
Raw connection	2100 + port number	To specify port 2, use 2102

9. If you want the autoconnection to launch immediately, choose Force DCD.
10. Choose Binary Mode.
11. When you complete the configuration process, choose Submit.

## Configuring UDP Multicast

The Digi One and PortServer TS devices are devices capable of UDP multicast. UDP multicast is used to send serial data over an Ethernet cable to one or many hosts at the same time. UDP is a connectionless protocol, meaning UDP does not need a protocol, but is sending data without any form of acknowledgement or error correction. Up to 64 devices can receive a UDP multicast at one time. Both the transmitting and receiving devices must be configured properly for UDP multicast to work.

This section describes how to use the web interface to configure this Digi device for the following:

- Inbound connections, that is, connections that are initiated by the device on the other side of the network
- Outbound connection, that is, connections that are initiated by the device connected to the serial port

### Procedure for Configuring Outbound Socket Communication

1. Access the web interface by entering the device server IP address in a browser's URL window.
2. Log on to the Digi One/PortServer TS as `root`. The default password is `dbps`.
3. From the main menu, choose `Configure > Port`.
4. From the Port configuration screen, set the Device type to `Printer`, adjust other serial port communication parameters as required by the connected device, and then choose `Advanced`.

Note: The serial parameters for two connecting devices must match meaning if one device is set for 9600 bps, the other device must be set for the same rate.

- Choose UDP serial... at the bottom of the page. The UDP Serial Configuration page is displayed.

Delimiting string configuration

Forward buffer when the following string is found

- CR (carriage return)
- CR/LF (carriage return/line feed)
- Custom string

Strip string before forwarding

---

Timer/idle delay settings

Forward buffer after the following number of milliseconds

ms (1-60000)

- System default
- Disabled

---

Buffer settings

Forward buffer after the following number of bytes

bytes (1-4k)

- System default

Destination list:

Description	IP Address	UDP Port
<input type="button" value="Add destination"/> <input type="button" value="Submit"/> <input type="button" value="Help"/>		

- Fill in the requested information and choose Add destination at the bottom of the page. See the Help section for additional information on the settings.
- Scroll to the bottom of the page. Under Description, choose updstest1.
- Enter the requested information and choose Submit. You can change the Description as desired. The IP address is the destination device server's address and the UDP port uses a base socket number of 2100 for UDP. The first port would be port number 2101.
- Repeat these steps until you have added the necessary destinations.

### Procedure for Configuring Inbound Socket Communication

- Access the web interface by entering the Digi One/PortServer TS IP address in a browser's URL window.
- Log on to the Digi One/PortServer TS as `root`. The default password is `dbps`.
- From the main menu, choose Configure > Port.

4. From the Port configuration screen, set the Device type to Printer, adjust other serial port communication parameters as required by the connected device, and then choose Submit.



## Configuring Static Routes

This section describes how to configure device server for static routes.

### Related Information

See the `set route` command in the *Digi One/PortServer TS Command Reference*.

### Procedure

To configure a static route over a PPP link, enter the following command:

```
set route net=addr mask=mask metric=hops wanname=interface
      gateway=gateway
```

where

- *addr* is either the IP address of a system to be reached over this route or the network address of the subnet that is to be reached on this route
- *mask* is the mask to use for interpreting the IP address.
- *metric* is the number of hop to the destination
- *interface* is either `ether` if this route is over the Ethernet interface or the name of a user if the route is over a PPP link
- *gateway* is the IP address of the device that is the next hop to the destination

### Example: Route Using the Ethernet Interface

In this example, a route to a subnet is created over the Ethernet interface. Key features include the following:

- The address on the `net` field is a subnetwork address, not the IP address of a specific device
- The `wanname=ether`, indicating that this route is over the Ethernet interface
- The `metric` field indicates that packets to this subnet will pass through two routers
- The `gateway` field indicates that all packets using this route are to be forwarded to the device at IP address 191.21.21.2.

```
set route net=199.21.33.0 mask=255.255.255.0 metric=2
      wanname=ether gateway=199.21.21.2
```

### Example: Route Using a PPP Link

In this example, a route to a subnet is created over a PPP interface. Key features include the following:

- The address on the `net` field is IP address of a specific device, not a subnetwork address
- The `wan` name is the name of a PPP user.

- The metric field indicates that packets to this subnet will pass through two routers
- The gateway field indicates that all packets using this route are to be forwarded to the device at IP address 191.21.21.2.

```
set route net=199.21.33.44 mask=255.255.255.255 metric=2
wannname=ppp1 gateway=199.21.21.2
```

## Configuring Dynamic Routes Using RIP

This section describes how to configure device server for dynamic routing.

### Related Information

See the set forwarding command in the *Digi One/PortServer TS Command Reference*.

### Starting Point

This procedure assumes that you have signed on as root and have or will configure modems, modem scripts, devices, and filters for routes that use serial lines.

### Procedure

1. Configure the links over which routed packets and RIP updates will be sent.
  - To enable routing over the LAN to which device server is attached, no routing-specific configuration is required.
  - To enable routing over PPP links be sure to use the netrouting field on the set user command to configure how device server handles RIP updates. You can configure the link so that device server does any of the following with RIP updates:
    - Both sends and receives them (netrouting=both)
    - Sends them only (netrouting=send)
    - Receives them only (netrouting=receive)
    - Neither sends nor receives them (netrouting=off)
2. Configure the device server for dynamic routing with a set forwarding command that specifies state=active.

### Example: Dynamic Routes

In this example, which shows only those commands and command fields pertinent to routing, device server is configured for dynamic routing using RIP. But to prevent RIP updates from being sent across the PPP link, the set user command that defines the link specifies netrouting=off.

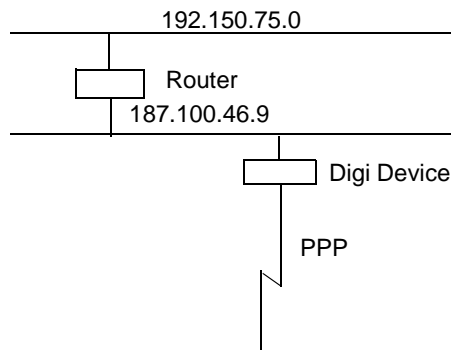

```
set forwarding state=active poisonreverse=on splithorizon=on
set user name=link1...netrouting=off
```

## Configuring Proxy ARP

This section describes how to configure device server for Proxy ARP.

### Related Information

See the set forwarding command in the *Digi One/PortServer TS Command Reference*.

### Starting Point

This procedure assumes that you have signed on as root and have or will configure modems, modem scripts, devices, and filters for routes that use serial lines.

### Procedure

1. Configure the links over which packets will be routed using a set user command. This command must specify (on the ipaddr field) a specific IP address for the remote system using the Proxy ARP service.
2. Configure device server for Proxy ARP by supplying a set forwarding command that specifies the following:
  - state=passive
  - proxyarp=on

### Example

In this example, device server provides Proxy ARP services to a remote host.

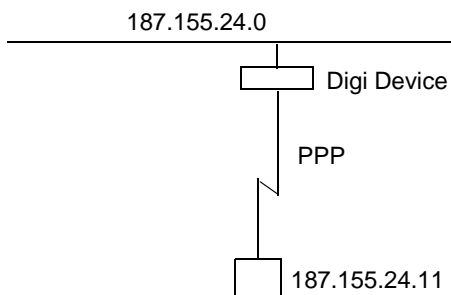

```
set user name=link1...ipaddr=187.155.24.11
set forwarding state=passive proxyarp=on
```



## Configuring Modbus

Modbus is a protocol that defines how devices in an industrial automation (IA) environment communicate. It specifies that a controlling unit, called a master, manages one or more units, called slaves. The protocol specifies that only the master may initiate communication. Slaves may only respond.

The protocol defines the structure of Modbus messages, determines how the master requests information from the slave or specifies an action for the slave to take, defines how the slave is to respond, specifies addressing conventions, and deals with many of the other details required for communication to occur. Modbus defines two encoding schemes, Modbus ASCII and Modbus RTU. Each Modbus device uses one or the other.

Designed to function over a serial communication cable, Modbus has been extended in recent years to function over an Ethernet network using Modbus/TCP, which defines a method of encapsulating Modbus ASCII or Modbus RTU messages in IP packets for transport over the network.

The extremely flexible Digi implementation includes support for Modbus ASCII, Modbus RTU, Modbus/TCP, and two other methods of transport over a network, TCP socket and UDP socket communication. The implementation enables multiple network-based masters to concurrently initiate communication with serial-based slaves using any of the supported network protocols.

### Modbus Configuration Procedure

Use the `setia` command from the `See the Digi One/PortServer TS Command Reference for information.`

- Configure the serial port for the serial communication parameters (baud rate, data bits, parity and stop bits) required by the connected IA device.
- Choose Modbus ASCII or Modbus RTU as the serial port protocol, depending on the requirements of the IA device connected to the port.
- If you configure the port for a slave, you do not have to configure a network-based master. Communication with the master just works. (If the master is connected to a serial port, it must be configured, however.)
- If you configure a port for a master and the slaves are located on the network, TCP sockets, UDP sockets, and Modbus/TCP are all supported. Use the protocol required by the master.

## Configuring the User-Defined Protocol

Digi One\PortServer TS 2/4 MEI devices support what Digi calls the “user-defined” protocol, which is any IA serial-port protocol with the following attributes:

- All message packets are bounded by fixed header and trailer strings.
- Each protocol request is followed by a single response.

#### **Modbus Configuration Procedure**

Use the `setia` command from the See the *Digi One/PortServer TS Command Reference* for information.

- Configure the serial port for serial communication parameters (baud rate, data bits, parity and stop bits) required by the connected IA device.
- Choose User-defined as the serial-port protocol.
- If you configure the port for a slave, you do not have to configure a network-based master. Communication with the master just works. (If the master is connected to a serial port, it must be configured, however.)
- If you configure a port for a master and the slaves are located on the network, TCP sockets and UDP sockets are supported options.

### Controlling Access to the Configuration

Controlling access of device server restricts access to the configuration by defining the following types of users:

- The root user, who has unlimited access to device server commands. He or she can view any configuration table and change any configuration parameter. The root is identified by the user name `root` and must supply a password to be authenticated. The default root password is `dbps`. You should change this password immediately.
- Regular users, who have much more restricted access to device server commands. Regular users can view some configuration tables and can change some configuration parameters related to their own sessions and passwords. See the *Digi One/PortServer TS Command Reference* for information on the limitations placed on regular users for each command.

### Controlling Access to Inbound Ports

This section describes methods of controlling access to inbound serial ports. An inbound port is one defined on the `dev` field of the `set ports` command for one of the following device types:

- `term` (used to define terminal connections)
- `min` (used to define incoming modem connections)
- `mio` (used to define bi-directional modem connections)
- `hdial, hio` (used to define computer connections)

#### Default Access Restrictions

The default configuration for inbound ports is that a login and password are required to access them.

#### Options for Removing Access Restriction

The login and password requirement for inbound ports can be changed by configuring

- The port so that it does not require a login and password. In this case, no one is required to supply a login or password.
- Specific users so that they do not require a password. In this case, some users do not supply passwords, and others are required to.

#### Procedure for Changing a Port's Access Requirements

To configure a port so that no one has to login or specify a password, supply a `set logins` command that specifies the following:

```
set logins range=range login=off passwd=off
```

**Example:**

```
set logins range=1-2 login=off passwd=off
```

**Procedure for Changing a User's Access Requirements**

To configure a user so that he or she does not have to specify a password when accessing an inbound port, supply a set user command that specifies the following:

```
set user name=name password=off
```

where *name* is a name to identify the user

**Example:**

```
set user name=user1 password=off
```

## Controlling Access to Outbound Ports

This section describes methods for controlling access to outbound serial ports. An outbound port is one defined on the dev field of the set ports command for one of the following device types:

- prn (used to define printer connections)
- mout (used to define outbound modem connections)
- mio (used to define bi-directional modem connections)
- host (used to define host connections)

**Default Access**

The default for outbound ports is unlimited access.

**Restricting Access to Outbound Ports**

Use the set auth command to restrict access to outbound ports. See the description of the set auth command in the *Digi One/PortServer TS Command Reference* for more information.

**CHAP Authentication for PPP Users**

CHAP authentication can be used to restrict PPP user access to outbound ports. For more information on CHAP configuration, see the set user command in the device server *Command Reference*.

## Controlling Access to the Command Line

This section describes how to restrict access to the device server command line.

**Method 1 Autoconnection**

The autoconnection feature allows you to configure a user to access the device server but then be automatically connected to a host on the LAN.

You can implement autoconnection in the following ways:

- By port where all port users are automatically connected to the same host. The device server is completely transparent to them.

- By user where a user is required to login and may be required to supply a password, but once the user is authenticated, an automatic connection to a hosts made.

For information on configuring autoconnection, see "" on page 51.

**Method 2: Menus**

Menus select destination systems without having to access the device server command line. For information on configuring menus, see the description of the set menu command in the *Digi One/PortServer TS Command Reference*.

**Issuing User Passwords**

This section discusses how to issue user passwords.

**Related Information**

See the newpass and set user commands in the *Digi One/PortServer TS Command Reference*.

**Starting Point**

This procedure assumes that you have signed on as root and already configured the user to whom you will be issuing a password.

**Procedure**

1. Issue a newpass command that identifies the user (on the name field) to whom this password will be issued.
2. When the system prompts you for a new password, type in the password and then press Enter.
3. When the system prompts you to enter the new password again, type it in and then press Enter.

**Configuring SSH Version 2 for Secure Communication**

This section discusses how to configure a user for SSH version 2 encryption.

This feature is only available for the following devices.

Device	Required Hardware	Required Firmware
Digi One TS	50000771-01A or higher	82000747a or higher
PortServer TS 2 MEI	50000771-02A or higher	
PortServer TS 4 MEI & Wireless	50000771-03A or higher	

**Password Protection**

To configure simple password authentication for an SSH user, no SSH-specific configuration is required. Simply configure a user by entering the following commands:

```
set user name=name password=on
```

```
newpass name=name
```

where *name* is a user name

### Example

```
set user name=ssh-user1
```

```
newpass name=ssh-user1
```

### Using a Public Key

To enable public key authentication and to associate a public key with a user, enter the following command:

```
set user name=name loadkey=host:key
```

where

- *name* is the name of a user
- *host* is either an IP address or DNS name of a host running TFTP that holds
- *key* is the name of a file that contains the DSA public key. If your host's implementation requires a complete path to the file, specify the path here as well.

Example:

```
set user name=secure loadkey=143.191.2.34:ssh-file
```

### Making Reverse SSH Connections to Ports

The convention used to identify a port for a reverse SSH connection to a Digi device is to use 2500 + the port number. See the examples that follow for more information.

#### *Example: Reverse SSH Connection to Port 1*

```
ssh 192.1.2.3 2501
```

#### *Example: Reverse SSH Connection to Port 4*

```
ssh 192.1.2.3 2504
```

## Controlling Access to Services

This section describes how to disable services, such as Telnet and Rlogin, for inbound users, which means that they cannot access the Digi device using those services. This feature allows you to turn off individual services or to specify a security level, which means that all services not included in that level are turned off.

### Services that Can Be Turned Off

The following services can be turned off.

- HTTP
- RealPort
- Reverse TCP
- Reverse Telnet
- Remote login
- Remote shell

- SNMP
- SSH
- Telnet

### **Service Levels**

These are the secure access levels:

- Secure, which means that SSH is the only service available to inbound users
- High, which means that SSH, HTTP, SNMP, and RealPort services are available to inbound users
- Normal, which means all services are available
- Custom, which means you can select services to turn off.

The default service level is normal, which means that all services are available.

### **Procedure**

Use this topic for information on using the web interface to turn services off.

1. Access the device server from a web browser by entering the Digi device's IP address in the URL window.
2. Log on as `root`. The default password is `dbps`.
3. From the main menu, choose Secure Access.
4. Use the wizard to disable services that you do not want to make available to inbound users. Use the context sensitive help for information on configuration fields.



## About the Domain Name System

This section discusses key concepts of the domain name system.

### Purpose of DNS

The domain name system maps domain names to information associated with these names, such as IP addresses.

### DNS Components

DNS components include:

- A distributed database consisting of domain names and associated information
- A hierarchical system of domain name servers that maintain the database and use it to respond to requests for information about a particular domain name, such as its IP address
- Domain name resolvers that
  - Accept requests from users
  - Satisfy information requests by building and submitting properly formulated queries to one or more name servers or by retrieving information from a local host file
  - Return information to users
  - Cache information for future use

### Types of Name Servers

There are two types of name servers in the domain name system:

- Local servers maintain information for resources within a local zone. It is up to individual network administrators to determine the scope of a local zone.
- Root servers maintain information in higher-level domains than do local servers.

Typically, when a user requires information about a domain name, the resolver queries a local server. If local servers cannot provide the information, root servers are queried next.

### Naming Conventions

Each node in the domain name system has a globally unique domain name that consists of its own name, which is called a label, and the labels of all superior nodes.

### DNS Name Example

Here is an example of a domain name. Note that labels are separated by periods:

`mn07.amalgamated.com`

In this example, `mn07` is part of the higher-level domain called

amalgamated.com.

## Configuration Procedures

### Procedure for Using a Name Server

To configure a DNS server, enter the following command:

```
set config domain=domain myname=name dns=ip-address
```

where

- *domain* is the domain in which the device server will reside
- *name* is a DNS name for device server
- *ip-address* is the IP address of a name server

Example:

```
set config domain=digi.com myname=poe dns=204.221.1.4
```

### Procedure for Using a Host File

Use this section to configure the host table, which maps IP addresses to host names.

Enter the following command

```
set host name=name ip=ip-address
```

where

- *name* is the name the host
- *ip-address* is the IP address of the host

### Example

In this example, three IP address-to-name mappings are configured

```
set host name=poe ip=204.221.110.200  
set host name=gary ip=204.221.110.202  
set host name=toni ip=204.221.110.203
```

### About SNMP and the device server Agent

This section introduces SNMP and network management in TCP/IP networks, and it describes the device server agent. It discusses the following:

- Network management components
- The SNMP agent
- SNMP traps
- The device server agent's MIB support
- The device server agent's supported traps

#### Network Management Components

The TCP/IP network management architecture contains the following components:

- Managed nodes such as host systems, routers, terminal and communications servers (such as device server) and other network devices
- One or more network managers (also called network management stations), which are the points from which the network is managed
- Agents that reside on managed nodes and retrieve management information and communicate this information to network managers
- The network management protocol, SNMP, which governs the exchange of information between the nodes and stations
- Management information, which is the database of information about managed objects. This database is called the management information base (MIB).

#### SNMP Management Agent

Each managed node contains at least one agent—a component that responds to requests from the network manager—that retrieves network management information from its node and notifies the manager when significant events occur.

#### SNMP Traps

A mechanism defined by SNMP is called a trap, which is a report or “alarm” from a managed node to an SNMP manager that a significant event has occurred.

#### MIB Support

The agent supports the following MIBs:

- Read-write for MIB II (RFC 1213), which is an Internet-standard MIB, consisting of managed objects from the systems, interfaces, IP, ICMP, TCP, UDP, transmission, and SNMP group

- Read-write for the character-stream devices using SMIv2 MIB (RFC 1658)
- Read-write for the RS-232-like hardware devices MIB (RFC 1659)
- Read-write for the device server IP Network Control Protocol of the Point-to-Point Protocol MIB (RFC 1473)

#### **Message Support**

The SNMP agent supports the Set, Get, GetNext, and Trap messages as defined in RFC 1157. These messages are used as follows:

- Set, which means set the value of a specific object from one of the supported MIBs
- Get, which means retrieve the value of a specific object from one of the supported MIBs
- GetNext, which means retrieve the value of the next object in the MIB
- Trap, which means send traps to the manager when a particular type of significant event occurs

#### **Supported Traps**

The agent can send traps when any of the following occur:

- Cold starts (device server initializes)
- Authentication failures
- Login attempts

### **Configuration Procedure: Web Interface**

1. Access the web interface by entering the device server IP address in a browser's URL window.
2. Log on to the device server as **root**.

Note: The default password is **dbps**, which should be changed. See the `newpass` command in the *Digi One/PortServer TS Command Reference* for information on changing passwords.

3. Select Configure and then SNMP from the menu.
4. Fill in the configuration fields and then click Submit.

## About Configuring Users

Although it is not required, the device server is often configured to accommodate the requirements of particular users. Typical configurable user attributes include the following:

- Whether the user is required to supply a password
- Autoconnection attributes, such as the system to which the user should be automatically connected at login
- The interface the device presents the user, such as a menu or command line
- Whether the user has access to outbound ports

Note: For information on configuring PPP users, see "Configuring PPP" on page 31.

### Configuration Methods

You can configure users in the following ways:

- With the web interface.
- With the set user command. See the set user command in the *Digi One/PortServer TS Command Reference*.

## Common User Features

This section discusses common user-related features. For a complete list, see the set user command in the *Digi One/PortServer TS Command Reference*.

Feature	Description	set user Field
auto connect	Automatically connects the user to the host specified on the autohost field using the service (TCP port) defined on the autoport or autoservice fields. Autoconnection can also be implemented by port instead of by user. This feature is configurable from the web interface.	autoconnect autohost autoport autoservice
Default access type	Defines the type of access the user is restricted to. Menu, command line, autoconnect, and outgoing and netservice are the types. This feature is configurable from the web interface.	defaultaccess
Menu access	Defines the menu that is to be presented to a user with menu access. This feature is configurable from the web interface.	menu
Port access	Defines the number of outbound ports a user connected over the LAN can access at one time. This feature is not configurable from the web interface.	maxsessions
PPP	Defines PPP-related parameters for the user.	There are too many fields to list here. See the set user command for more information.
Routing updates	Defines whether RIP routing updates are forwarded over the link to this user.	netrouting

## Configuring a User: Web Interface

Use this section to configure users with from the web interface.

1. Access the web interface by entering the device server IP address in a browser's URL window.
2. Log on to the device server as `root`. The default password is `dbps`.
3. Select Configure and then Users from the menu.
4. Choose Add User.
5. Enter a name and then choose Submit
6. Choose the new user from the Name column.
7. Configure the user as required.
8. Click Submit.
9. To return to the main User menu, click User from the Menu again.

## Commands for Configuring a User

Use the commands listed below as well as find specific examples and complete parameters from the *Digi One/PortServer TS Command Reference*.

- `set user (name=)`
- `newpass` to assign a password
- `default access=menu` to configure a user for a menu
- `autoconnect` to automatically connect a user
- `remove` to remove a user from the user table

## Upgrading the Firmware

This section describes how to upgrade the firmware, which can be done from the web interface using HTTP or FTP.

### HTTP or TFTP Upgrade Procedure

If your hardware is okay, make sure you are running the latest firmware version available. Check the Digi Support site for the latest firmware and/or POST updates for your device:

<http://ftp.digi.com/support/firmware>

1. Download a copy of the firmware file.
2. Access the Digi device server's web interface by entering the Digi device server's IP address in a browser's URL window and log on (User Name `root`, Password `dbps`).
3. Choose Update Firmware from main menu.
4. Browse to the location on your system where the firmware has been saved, select the correct file, and click Update.
5. Reboot the device when prompted.
6. Access the Digi device server's web interface and verify on the Information Page that the Firmware version has been successfully updated.

Do not leave your browser until you are prompted to reboot.

### Command Line

If you want to use the command line to upgrade firmware, use the boot command. See the *Digi One/PortServer TS Command Reference* for more information.

## Copying the Configuration to and from a Remote Host

This section discusses copying the configuration to a remote host and from a remote host, which means you can configure the Digi device remotely by entering commands in a text file and then copying the file to the Digi device.

### When To Use Remote Configuration

Typically, you use remote configuration when you have several device servers with similar configurations and want to keep a master configuration on a remote host, from which you can easily create variations for downloading to individual device servers.

### Rules for Editing a Configuration file

Here are some rules for editing a configuration file on a remote host:

- Edit the file with any text editor.

- Each line of the file must start with a set command, such as set user or set line. In other words, do not let commands wrap to the next line if your editor supports this function.

#### HTTP Procedure

1. Access the web interface by entering the device server IP address in a browser's URL window.
2. Log on to the device server as `root`. The default password is `dbps`.
3. From the main menu, choose Admin > HTTP CpConf.
4. To copy a file from the host you are on do the following:
  - Choose Browse, select the file, and then choose Submit.
  - Follow the prompts to complete this procedure.
5. To copy a file to a remote host, do the following:
  - Right click on the Download current config link.
  - Choose Save Target as
  - Specify a file name and then choose Save.
6. Follow the prompts to complete this task.

#### TFTP Procedure

1. Ensure that TFTP is running on the remote host.
2. Access the web interface by entering the device server IP address in a browser's URL window.
3. Log on to the device server as `root`. The default password is `dbps`.
4. From the main menu, choose Admin > TFTP CpConf.
5. Choose either Copy configuration to a TFTP server or Copy configuration from a TFTP server.
6. Specify an IP address and a file name and then choose Submit.
7. Follow the prompts to complete this task.

#### Command Line

If you want to use the command line to copy the configuration to and from a remote host, use the `cpconf` command. See the *Digi One/PortServer TS Command Reference* for more information.

## Resetting Device Server Configuration to Defaults

Use this topic to reset the device server configuration to defaults.

**Note:** This procedure causes the device server to lose all configuration changes. If you have a complex configuration, contact Digi before performing for information on saving your configuration. See "Specifications" on page 83 for information.

#### Procedure

1. Use a pen, the point of a paper clip, or some other device to press the recessed button on the front panel.
2. While holding down the button, power on the device server.

3. When the 1-5-1 LED pattern is displayed, release the button.  
The device boots up.

### **Commands for Resetting the Configuration to Defaults**

Use the revert command to reset the configuration to factory defaults or the latest version stored in NVRAM. See the *Digi One/PortServer TS Command Reference* for complete information.

Note: You can also use the range field on this command to define a range of ports with the serial, port, line, flow, keys and login options.



## Chapter 18 Configuring Power Over the Serial Ports

### Serial Power Feature

The Serial Power feature available for the Digi One TS, PortServer TS 2 MEI, and PortServer TS 4 MEI allows the Digi device to power a serial device (power out) or use a serial device to power the Digi device (power in). The advantage of this feature is to eliminate an external power supply. Power out is available on all ports through Ring Indicator (RI) or Data Terminal Ready (DTR). Power in is available only through RI and **only** on port one (1). The Serial Power feature is active on a specific port when that port is configured for RS 232 operation.

- The power out budget equals one (1) watt (the total amount of power available). The available power can be divided in any combination between the ports but the following rules must be observed:
  - RI = 5 volts @ up to 200 mA (max)
  - DTR = 9 volts @ up to 100 mA (max)
  - You may use DTR or RI as the source of power (power out) on any port but you may not use both DTR and RI on the same port.
- Pinout information
  - RI is pin 1
  - DTR is pin 9
- RI signaling is lost when the pin is used for power

### Configuring RI Power

#### RI Power In

Ring Indicator (RI) power in accepts power into the Digi device server **only** on port one. Power in is available using the RI pin. The Digi device requires power in the range of 9-30 VDC @ 525mA (max). Ports 2, 3, and 4 can still supply power to a serial device through the RI or DTR pins for each port. When using power in through the RI, the external power supplies (both powered Ethernet and the barrel connector power supply) are inoperative. Altpin will not work for RI power in.

1. Open the device unit enclosure and move the black jumpers to the following settings:
  - P-9 jumper on pins 2 and 3
  - P-6 jumper on pins 1 and 2

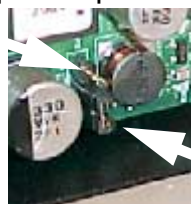

Note: The pins face each other on the board. That is P-9 pin 1 is straight across from P-6 pin 3. When the jumpers are placed correctly for power in, the jumpers will set on the pins closest to the edge of the board. The left arrow indicates the open pin and the right arrow is pointing to the jumper.

2. Close the device unit enclosure.

#### RI Power Out

Ring Indicator (RI) power out is available on all ports. The total power budget for this feature is one (1) watt not to exceed 5 volts @ up to 200mA on any single port. The following procedure assumes the unit will only be used for RI power out.

1. Set the port DIP switches to the following places: switch 1 and 3 are up and 2 and 4 are down (see "Serial Power Table" on page 80 for illustration).
2. Enable the RI power through the web interface.
3. Connect power supply with the barrel-connector power supply provided with the device or use powered Ethernet.

Note: If the unit will be used with RI power in (port 1 only), set the jumpers to the settings listed below  
P-9 jumper on pins 2 and 3  
P-6 jumper on pins 1 and 2  
and do not use an external power source. Port 1 cannot be used for both power in and power out.

## Configuring DTR Power

#### Power Out

Data Terminal Ready (DTR) power out is the factory default on the Digi device server. Total power budget for this feature is one watt not to exceed 9 volts @ up to 100mA to any single port.



1. Set the port DIP switches to EIA 232 (switch 1 is up, 2,3, and 4 are down) to enable DTR power.
2. Open the port and set DTR high.

Note Here are the pins to verify the jumper position. The **default** position has the jumpers on the two pins furthest from the edge. **DO NOT MOVE THE JUMPERS FROM THE DEFAULT UNLESS USING RI POWER IN.**



## Serial Power Table

Use this table for summary information for a serial power setup.

Quick Summary Table for Setup of Serial Power	DTR Power	RI Power	
	OUT	OUT	IN
Switch Settings			
DTR setting	DTR ON	DTR OFF	DTR OFF
Ports Allowed	1, 2, 3, 4	1*, 2, 3, 4 *unless port 1 is used for power in	1
Jumper Pin Settings	P-9 jumper on pins 1 & 2 P-6 jumper on pins 2 & 3 (Factory Default)	P-9 jumper on pins 1 & 2 P-6 jumper on pins 2 & 3 (Factory Default)	P-9 jumper on pins 2 & 3 P-6 jumper on pins 1 & 2
Power Budget	9v @ up to 100mA one watt	5v @ up to 200 mA one watt	9 -30 v @ up to 525mA (max)



## Specifications

## LEDs

LED	Color	State	Indicates
Power	Green (labeled PWR)	On	Power detected
		Steady blinking	Waiting for an IP address
		Blinking 1-1-1	Starting the EOS
		Blinking 1-3-1	Starting the TFTP process
		Blinking 1-5-1	Configuration returned to factory defaults
		Off	No power detected
Radio Signal Strength	Yellow	Varying brightness	Signal strength relates to brightness or dimness of the light
Status (Link)	Green	On	Physical network detected
		Off	No physical network detected
ACT	Yellow	On	Bad initialization
		Off	Ready
		Blinking	Network activity

## LED Diagnostics

LED Activity	Indication
1-1-1 pattern	Starting the EOS.
1-3-1 pattern	TFTP boot process started
1-5-1 pattern	Tells you that configuration has been return to the factory configuration. See "Managing the OS and Configuration" on page 75.
Steady blinking	Device seeking an IP address from DHCP server.
Solid	On Digi One RealPort and PortServer TS 2/4 devices, this means the boot completed sucessfully.

## Device Server EIA 232/422/485 Switch Settings

Function	Switch Settings			
	1	2	3	4
EIA-232	Up	Down	Down	Down
EIA-422/485 Full-duplex	Down	Up	Down	If up, termination. If down, no termination
EIA-485 half-duplex	Down	Down	Up	

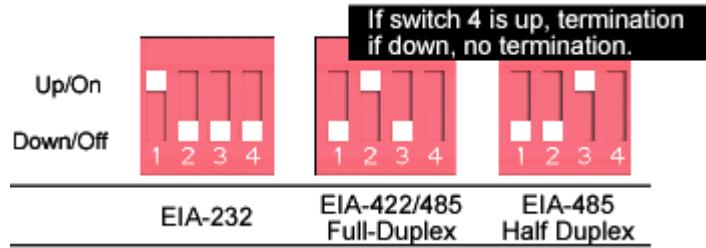



### DB9 Pinouts

DB9 Pin	EIA-232	EIA-422/485 Full-Duplex	EIA-485 Half-Duplex
1	DCD	CTS-	Not used
2	RxD	RxD+	RxD+
3	TxD	TxD+	TxD+
4	DTR	RTS-	Not used
5	GND	GND	GND
6	DSR	RxD-	RxD-
7	RTS	RTS+	Not used
8	CTS	CTS+	Not used
9	NA	TxD-	TxD-

**WARNING:** To prevent electric shock, do not remove the cover of this module while unit is powered up. There are no user-serviceable parts inside. Refer servicing to qualified personnel.

**CAUTION:** This unit has two power inputs. For total isolation from electrical shock and energy hazard, disconnect both power inputs. The device is intended to be mounted in an indoor only type system.

## Standard Models Specifications

<b>Power Requirements (Standard Models)</b>	
2-contact barrel connector 	+9 to +30 VDC 525 mA (max) external power supply
RJ-45 Powered Ethernet 	+30 to +60 VDC 100 mA (max)
<b>Environmental</b>	
Ambient temperature	0 to 50° Celsius 32 to 131° Fahrenheit
Relative humidity	5% to 90% non-condensing
Altitude	0 to 12,000 feet 0 to 3,658 meters
<b>Mechanical</b>	
Length	13.33 centimeters 5.25 inches
Width	8.25 centimeters 3.25 inches
Height	1.90 centimeters .75 inches
Weight	.227 Kilos 8 ounces

## Specifications for Extended Temperature Models

Power Requirements (Extended Temperature Models)	
2-contact barrel connector 	+9 to +30 VDC 525 mA (max) external power supply
Environmental	
Ambient temperature	-35 to 70 °Celsius -31 to 158 °Fahrenheit
Relative humidity	5% to 90% non-condensing
Altitude	0 to 12,000 feet 0 to 3,658 meters
Mechanical	
Length	13.33 centimeters 5.25 inches
Width	8.25 centimeters 3.25 inches
Height	1.90 centimeters .75 inches
Weight	.227 Kilos 8 ounces

## FCC Part 15 Class A

### Radio Frequency Interference (RFI) (FCC 15.105)

This equipment has been tested and found to comply with the limits for Class A digital devices pursuant to Part 15 of the FCC Rules. These limits are designed to provide reasonable protection against harmful interference in a residential environment. This equipment generates, uses, and can radiate radio frequency energy, and if not installed and used in accordance with the instruction manual, may cause harmful interference to radio communications. However, there is no guarantee that interference will not occur in a particular installation. If this equipment does cause harmful interference to radio or television reception, which can be determined by turning the equipment off and on, the user is encouraged to try and correct the interference by one or more of the following measures:

- Reorient or relocate the receiving antenna.
- Increase the separation between the equipment and the receiver.
- Connect the equipment into an outlet on a circuit different from that to which the receiver is connected.

- Consult the dealer or an experienced radio/TV technician for help.

**Labeling Requirements (FCC 15.19)**

This device complies with Part 15 of FCC rules. Operation is subject to the following two conditions: (1) this device may not cause harmful interference, and (2) this device must accept any interference received, including interference that may cause undesired operation.

**Modifications (FCC 15.21)**

Changes or modifications to this equipment not expressly approved by Digi may void the user's authority to operate this equipment.

**Cables (FCC 15.27)**

Shielded cables *must* be used to remain within the Class A limitations.

**ICES 003 Class A**

This digital apparatus does not exceed the Class A limits for radio noise emissions from digital apparatus set out in the Radio Interference Regulations of the Canadian Department of Communications.

Le present appareil numerique n'emet pas de bruits radioelectriques depassant les limites applicables aux appareils numeriques de la class A prescrites dans le Reglement sur le brouillage radioelectrique edicte par le ministere des Communications du Canada.

**Digi Contact Information**

Digi International  
 11001 Bren Road East  
 Minnetonka, MN 55343  
 U.S.A.

<b>Digi Contacts</b>	
World Wide Web:	<a href="http://digi.com">http://digi.com</a>
email	<a href="mailto:digi.info@digi.com">digi.info@digi.com</a>
Telephone (U.S.)	1-952-912-3444
Telephone (other locations)	(+011) 952-912-3444

